



by Schneider Electric

Installation Smart-UPS™ RT SRTG8K-SRTG10K Tower/Rack-Mount

Important Safety Instructions

Read these instructions carefully and look at the equipment to become familiar with the device before trying to install, operate, service or maintain it. The following special messages may appear throughout this document or on the equipment to warn of potential hazards or to call attention to information that clarifies or simplifies a procedure.



The addition of this symbol to either a “Danger” or “Warning” safety label indicates that an electrical hazard exists which will result in personal injury if the instructions are not followed.



This is the safety alert symbol. It is used to alert you to potential personal injury hazards. Obey all safety messages that follow this symbol to avoid possible injury or death.

DANGER

DANGER indicates a hazardous situation which, if not avoided, **will result in death** or serious injury.

WARNING

WARNING indicates a hazardous situation which, if not avoided, **could result in death** or serious injury.

CAUTION

CAUTION indicates a hazardous situation which, if not avoided, **could result in** minor or moderate injury.

NOTICE

NOTICE is used to address practices not related to physical injury.

Product Handling Guidelines



<18 kg
<40 lb



18-32 kg
40-70 lb



32-55 kg
70-120 lb



>55 kg
>120 lb



Safety and General Information

Inspect the package contents upon receipt.

Notify the carrier and dealer if there is any damage.

- Changes and modifications to this unit not expressly approved by APC by Schneider Electric could void the warranty.
- This unit is intended only for indoor use in a controlled environment.
- Do not operate this unit in direct sunlight, in contact with fluids, or where there is excessive dust or humidity.
- Be sure the air vents on this unit are not blocked. Allow adequate space for proper ventilation.
- For a UPS with a factory installed power cord, connect the UPS power cable directly to a wall outlet. Do not use surge protectors or extension cords.
- The battery typically lasts for two to five years. Environmental factors impact battery life. Elevated ambient temperatures, poor quality utility power, causing frequent short duration discharges will shorten battery life.
- Up to 4 external battery packs (XLBP) can be connected to the UPS in parallel. The number of external battery packs connected can be set using the LCD display.
Note: For each XLBP added, increased recharge time will be required.
- The equipment is heavy. Always practice safe lifting techniques adequate for the weight of the equipment.
- The batteries are heavy. Remove the batteries before installing the UPS and external battery packs (XLBPs), in a rack.
- Always install XLBPs at the bottom in rack-mount configurations. The UPS must be installed above the XLBPs.
- Always install peripheral equipment above the UPS in rack-mount configurations.
- Additional safety information can be found in the Safety Guide supplied with this unit.

Deenergizing safety

The UPS contains separate battery pack and may present a shock hazard even when disconnected from the branch circuit (mains). The AC output connectors may be energized by remote or automatic control at any time.

Before installing or servicing the equipment check that the:

- Input wall circuit breaker is in the OFF position.
- Internal UPS batteries are removed.
- XLBP battery modules are disconnected.

Electrical safety

- For models with a hardwired input, the connection to the branch circuit (mains) must be performed by a qualified electrician.
- 230 V models only: In order to maintain compliance with the EMC directive for products sold in Europe, output cords attached to the UPS must not exceed 10 meters in length.
- The protective earth conductor for the UPS carries the leakage current from the load devices (computer equipment). An insulated ground conductor is to be installed as part of the branch circuit that supplies input power to the UPS. The conductor must have the same size and insulation material as the grounded and ungrounded branch circuit supply conductors. The conductor will typically be green and with or without a yellow stripe.
- The UPS input ground conductor must be properly bonded to protective earth at the service panel.
- If the UPS input power is supplied by a separately derived system, the ground conductor must be properly bonded at the supply transformer or motor generator set.

Battery safety

⚠ CAUTION

RISK OF FALLING OBJECTS

- The equipment is heavy. Each battery module weighs 16.5 kg (36.4 lb).
- Always practice safe lifting techniques adequate for the weight of the equipment.
- Remove the battery modules before installing the UPS.
- Use the battery module handle to slide the battery modules in or out of the UPS.
- Do not use the battery module handle to lift or carry the battery module.

Failure to follow these instructions can result in equipment damage and minor or moderate injury.

⚠ CAUTION

RISK OF HYDROGEN SULPHIDE GAS AND EXCESSIVE SMOKE

- Replace the battery at least every 5 years or at the end of its service life, whichever is earlier
- Replace the battery immediately when the UPS indicates battery replacement is necessary.
- Replace batteries with the same number and type of batteries as originally installed in the equipment.
- Replace the battery immediately when the UPS indicates a battery over temperature condition, or when there is evidence of electrolyte leakage. Power off the UPS, unplug it from the AC input, and disconnect the batteries. Do not operate the UPS until the batteries have been replaced.
- *Replace all battery modules (including the modules in External Battery Packs) which are older than one year, when installing additional battery packs or replacing the battery module(s).

Failure to follow these instructions can result in minor or moderate injury and equipment damage.

* Contact APC by Schneider Electric Customer Support to determine the age of the installed battery modules.

- Before replacing batteries, remove conductive jewelry such as chains, wrist watches, and rings. High energy through conductive materials could cause severe burns.
- Do not dispose of batteries by burning them. The batteries may explode.
- Do not open or mutilate batteries. Released electrolyte is harmful to the skin and eyes, and may be toxic.
- Servicing of user replaceable batteries should be performed or supervised by personnel knowledgeable about batteries and required precautions.
- A battery can present a risk of electric shock and burns by high short-circuit current.
- Failed batteries can reach temperatures that exceed the burn thresholds for touchable surfaces.

Hardwire safety

- Verify that all branch circuit (mains) and low voltage (control) circuits are de-energized, and locked out before installing cables or making connections, whether in the junction box or to the UPS.
- Wiring by a qualified electrician is required.
- Check national and local codes before wiring.
- Strain relief is required for all hardwiring (not supplied). Snap in type strain reliefs are recommended.
- All openings that allow access to UPS hardwire terminals must be covered. Failure to do so may result in personal injury or equipment damage.
- Select wire size and connectors according to national and local codes.

General information







- The model and serial numbers are located on a small, rear panel label.
- Always recycle used batteries.
- Recycle the package materials or save them for reuse.

Radio frequency warning

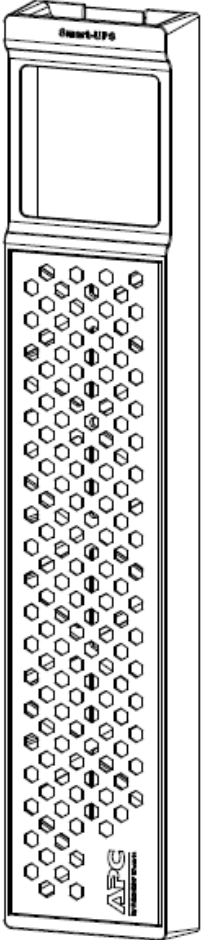
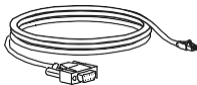
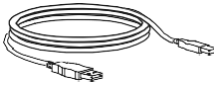
This UPS is a category C3 product as per IEC 62040-2, meant for commercial and industrial application in the second environment installation restrictions or additional measures may be needed to prevent disturbances.

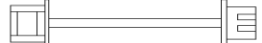
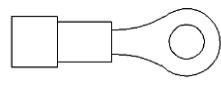
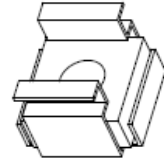
Package Contents

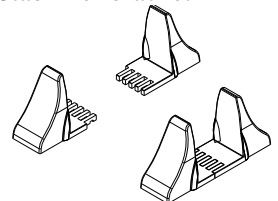
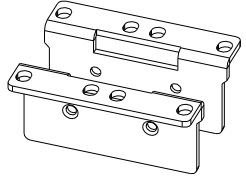
Inspect the contents upon receipt. Notify the carrier and dealer if the unit is damaged.

Included with all models:			
<p>Front bezel</p>  <p>(x1)</p>	<p>RJ45 to DB9 cable</p>  <p>(x1)</p> <p>USB cable</p>  <p>(x1)</p> <p>C13/C14, 10 A, 1.5 m</p>  <p>(x1)</p> <p>C19/C20, 16 A, 1.5 m</p>  <p>(x1)</p> <p>Battery pack temperature sensor wire</p>  <p>(x1)</p>	<p>Terminal</p>  <p>(x5)</p> <p>M5 Floating nut for secure the UPS to the pillar</p>  <p>(x4)</p> <p>M5x12 Phillips flat head screw to secure the UPS to the pillar</p>  <p>(x4)</p> <p>M4x6 flat head screws to secure the rack-mount brackets to the UPS.</p>  <p>(x4)</p>	<p>Stabilizer bracket</p>  <p>(x2 pairs)</p> <p>Rack-mount brackets</p>  <p>(x1 pair)</p> <p>Installation manual</p>  <p>(x1)</p> <p>Packing list</p>  <p>(x1)</p>

Included in the battery pack supplied with the UPS

Front bezel

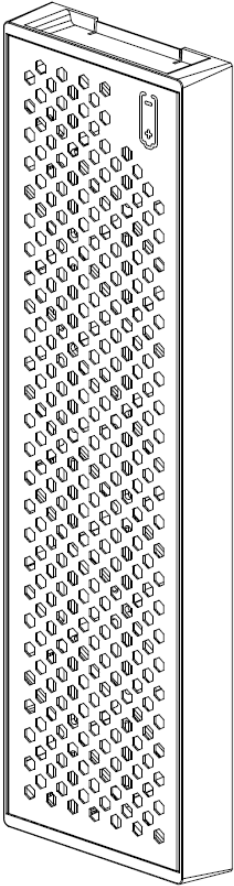

(x1)

M5 Floating nut secure the battery pack to the rack

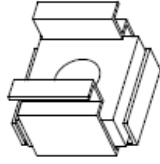

(x4)

M4x6 flat head screws to secure the rack-mount brackets to the battery pack



(x4)

M5x12 Phillips flat head screw to secure the battery pack to the rack



(x4)

Battery connector holder

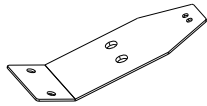

(x1)

Ground cable 0.74 m

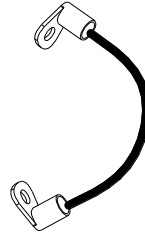

(x1)

Battery wire 0.64 m
Connect UPS and battery pack

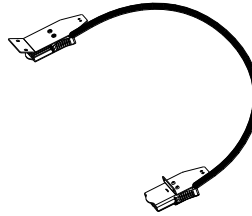

(x1)

Stabilizer bracket connectors

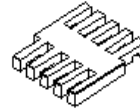

(x6)

Stabilizer bracket

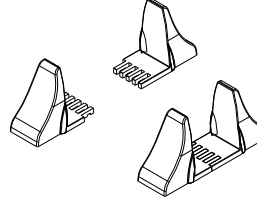

(x2 pairs)

Rack-mount brackets

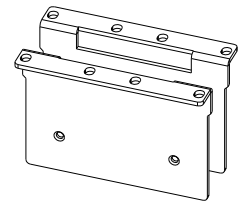

(x1 pair)

Installation manual



(x1)

Packing list



(x1)

Specifications

For additional specifications refer to the APC by Schneider Electric Web site, .

Environmental

Temperature	Operating	0 to 40 °C (32 to 104 °F)
	Storage	-15 to 45 °C (5 to 113 °F)
Maximum Elevation	Operating	0 - 3,000 m (0 - 10,000 ft) 0 - 1,000 m no derating; 1,000 to 3,000 m, power reduction of 1%/100 m
	Storage	0 to 15,000 m (0 to 50,000 ft)
Humidity	0% to 95% relative humidity, non-condensing	
International Protection Code	IP20	
<p>Note: Charge the battery modules every six months during storage.</p> <p>Environmental factors impact battery life. Elevated ambient temperatures, high humidity, poor quality mains power, causing frequent short duration discharges will shorten battery life.</p>		

Physical

The UPS is heavy. Follow all lifting guidelines.

	SRTG8KXLI/SRTG10KXLI
Unit weight without packaging	101.5 kg
Unit weight with packaging	124.5 kg
Unit dimensions without packaging Height x Width x Depth	217.5 x 440 x 680 mm (8.6 x 17.3 x 26.8 in)
Unit dimensions with packaging Height x Width x Depth	685 x 594 x 794 mm (27.0 x 23.4 x 31.3 in)
The model and serial numbers are on a small label located on the rear panel.	

Battery

UPS model	SRTG8KXLI SRTG10KXLI
XLBP model	SRTG192XLBP4
Replacement battery module This UPS has replaceable battery modules. Refer to the appropriate replacement battery user manual for installation instructions. Contact your dealer or go the APC by Schneider Electric Web site, . for information on replacement batteries.	APCRBC174
Total voltage of battery pack for the UPS	±96 VDC
Ah rating	5 Ah
Battery type	Sealed Maintenance Free Valve Regulated Lead Acid Battery
Number of battery pack	4 battery packs apart from the one supplied with UPS

UPS	XLBP	RBC	Rail Kit
SRTG8KXLI SRTG10KXLI	SRTG192XLBP4	APCRBC174	SRTGRK1

Electrical

Models	Rating
SRTG8KXLI	8 kVA / 8 kW
SRTG10KXLI	10 kVA / 10 kW

Output	
Output Frequency	50/60 Hz ± 4 Hz
Nominal Output Voltage	220/230/240 Vac
Input	
Input Frequency	40 Hz-70 Hz
Nominal Input Voltage	220/230/240 Vac

Rack Mount Installation

Refer to the Rail Kit Installation Guide for instructions on rail installation.

⚠ CAUTION

RISK OF FALLING OBJECTS

- The equipment is heavy. Always practice safe lifting techniques adequate for the weight of the equipment.
- Always use the recommended number of screws to secure brackets to the UPS.
- Always use the recommended number of screws and cage nuts to secure the UPS to the rack.
- Always install the UPS at the bottom of the rack.
- Always install the XLBP below the UPS in the rack.

Failure to follow these instructions can result in equipment damage and minor or moderate injury.

- 1 Install the battery pack in the rack before installing the UPS in the rack.

Refer to the installation manual provided with the battery pack for detailed instructions.

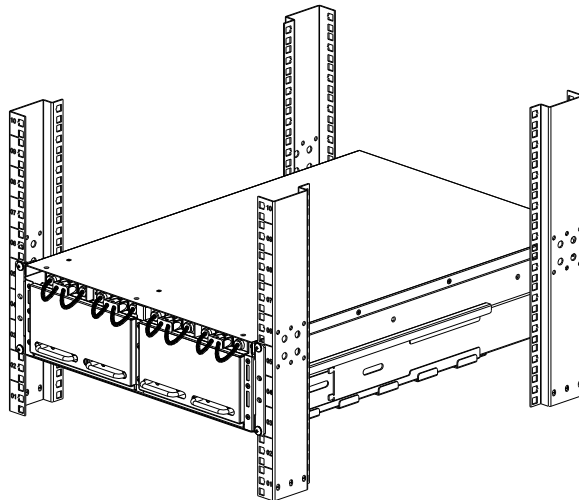

- 2 Secure the front of rail with 6 (M5x12) screws.

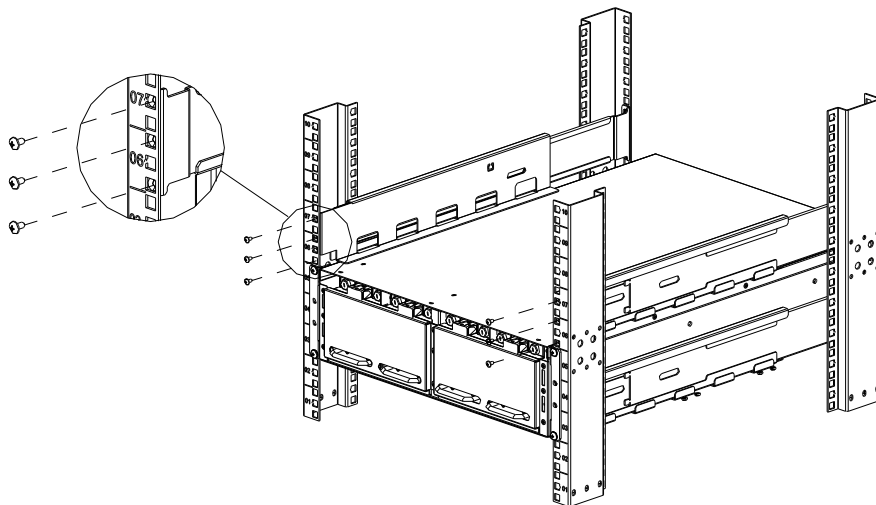

- 3 Secure the back of rail with 6 (M5x12) screws.

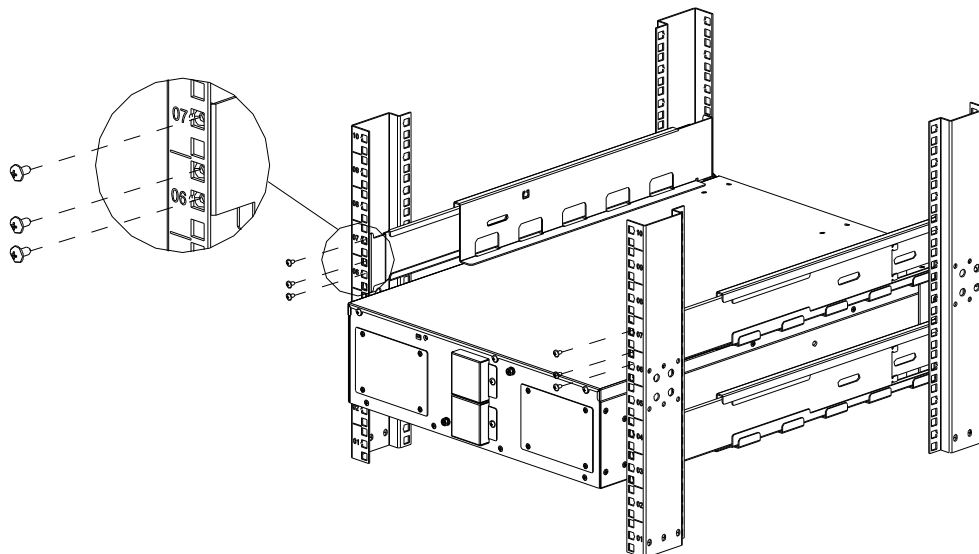

- 4 Secure the brackets on UPS module with 4 (M4x6) screws.

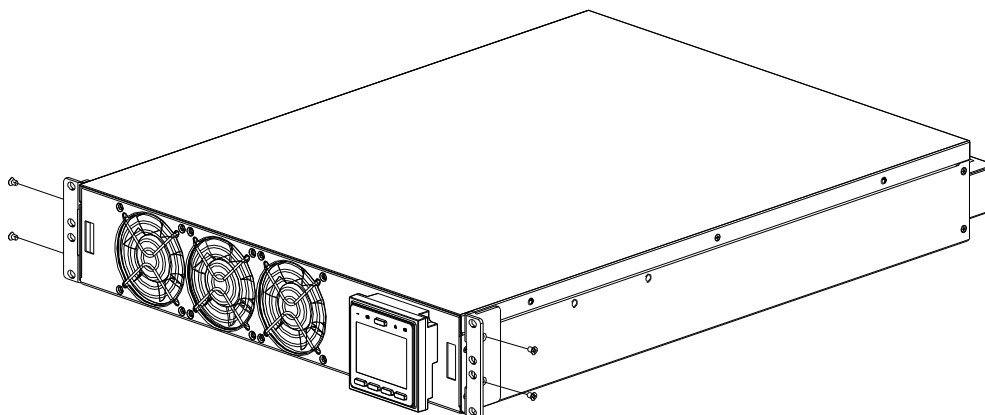

- 5 Rest the UPS module on the rail shelves.
Slide the UPS module into the rack.

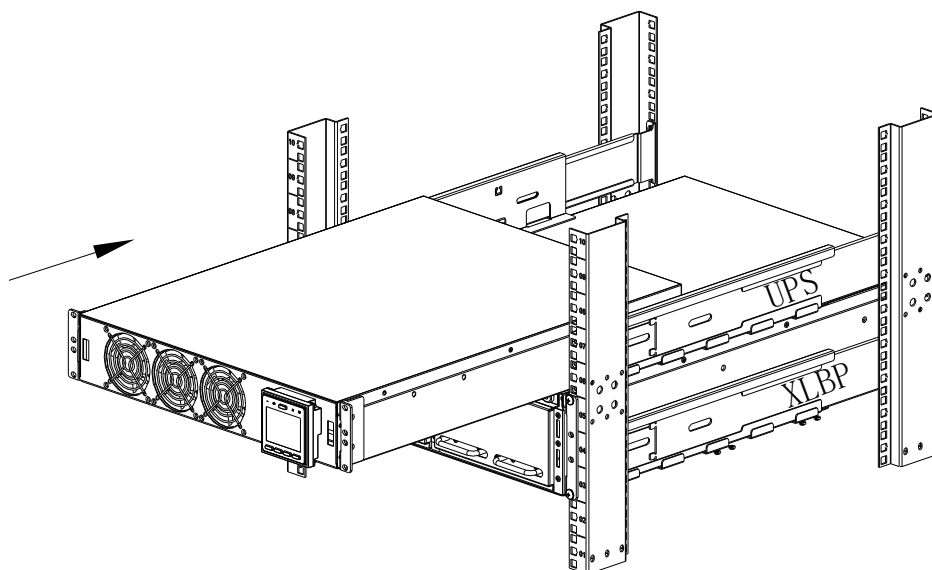

- 6 Secure brackets to pillar with 4 (M5x12) screws.

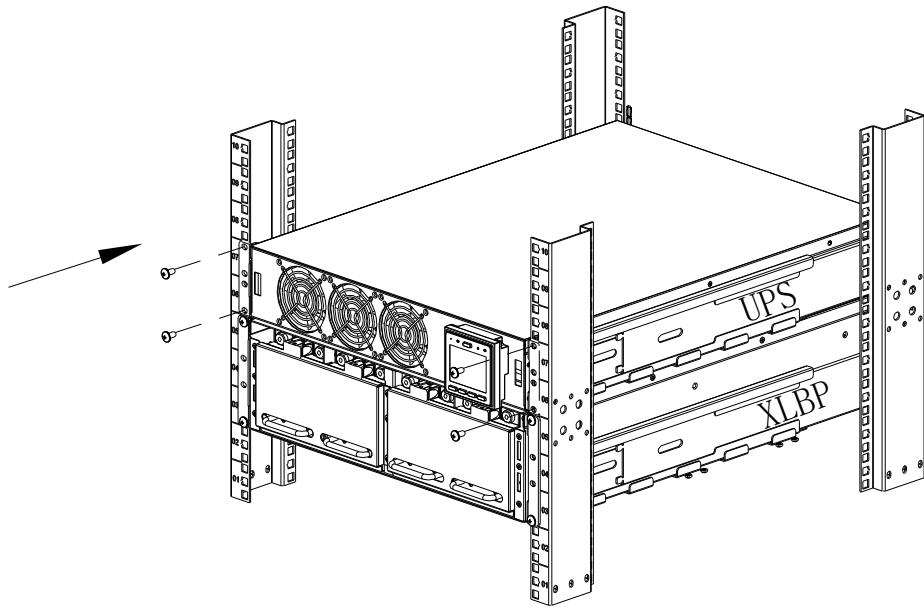

- 7 Install the front bezel of both the battery pack and the UPS.

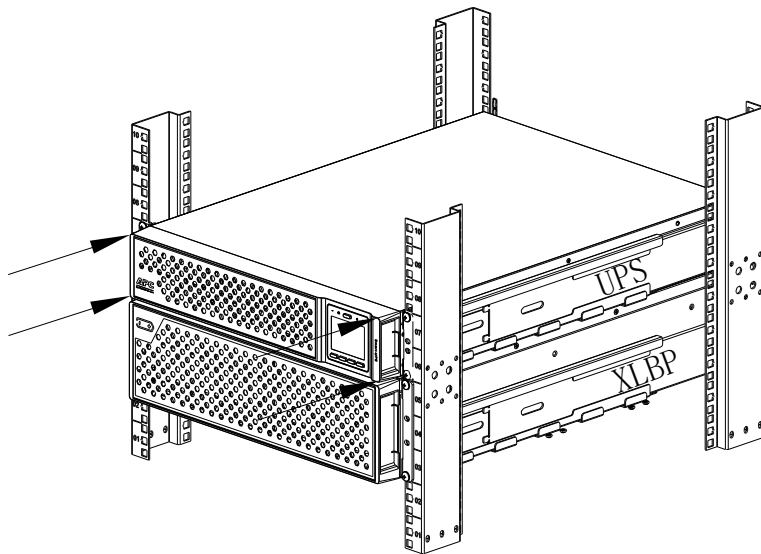

Tower Installation

⚠ CAUTION

RISK OF FALLING OBJECTS

- The equipment is heavy. Each battery module weighs 16.5 kg (36.4 lb).
- Always practice safe lifting techniques adequate for the weight of the equipment.
- Remove the battery modules before installing the UPS.
- Use the battery module handle to slide the battery modules in or out of the UPS.
- Do not use the battery module handle to lift or carry the battery module.

Failure to follow these instructions can result in equipment damage and minor or moderate injury.

- 1 Assemble UPS stabilizer bracket.

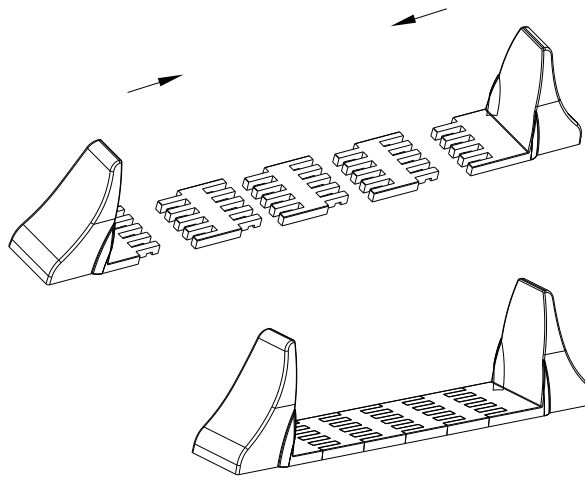

- 2 Disconnect battery.

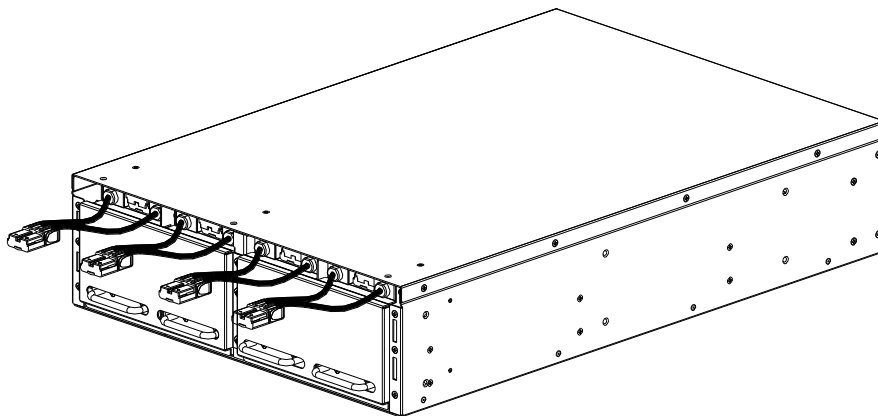

- 3 Remove the screws and battery compartment door.

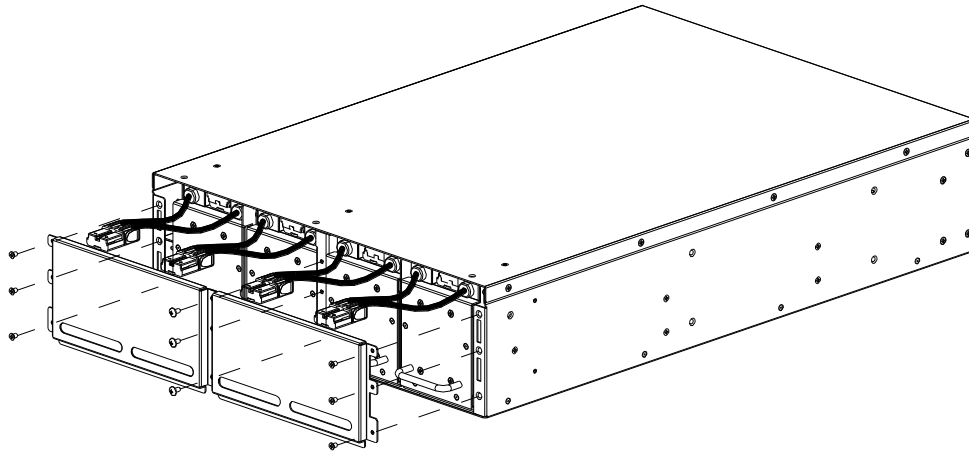

- 4 Remove the battery modules from the battery pack.

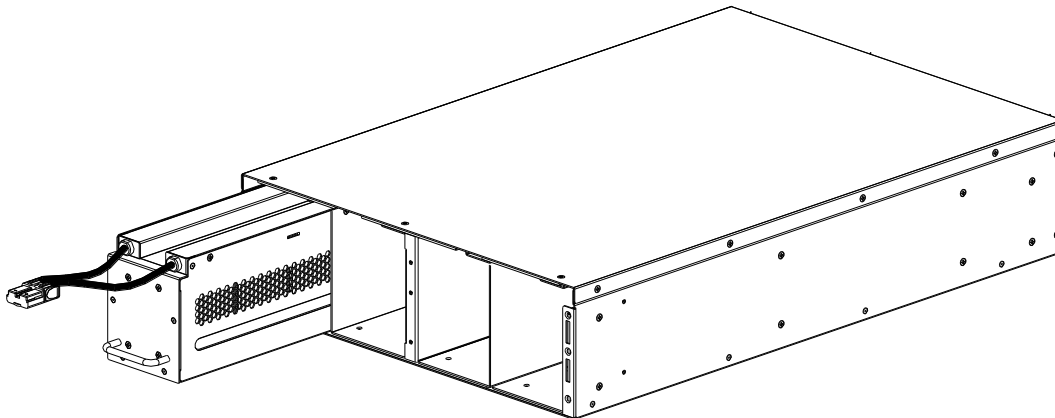

5 Mount the UPS and battery pack to the stabilizer bracket.

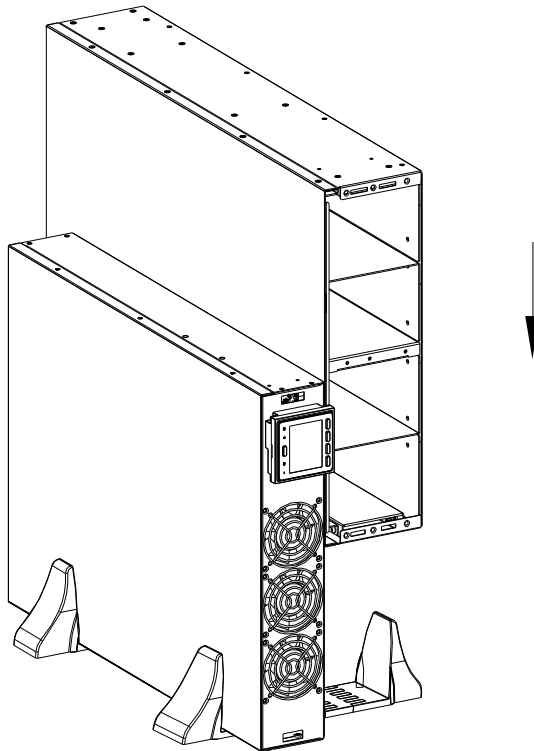

6 Rotate the LCD of UPS module 90 degrees to the right.

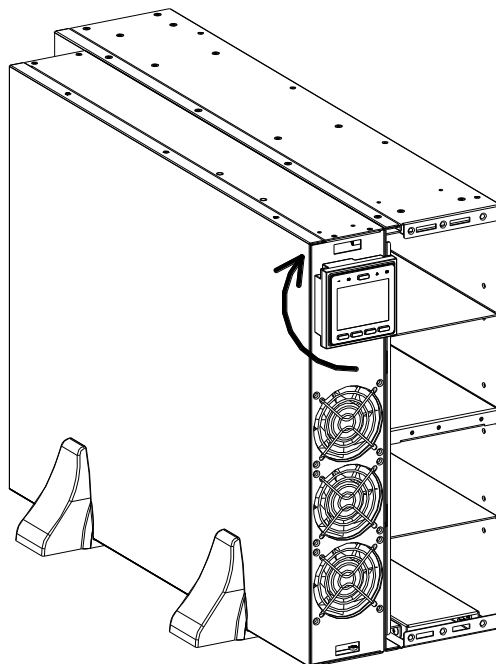

7 Install four battery modules.

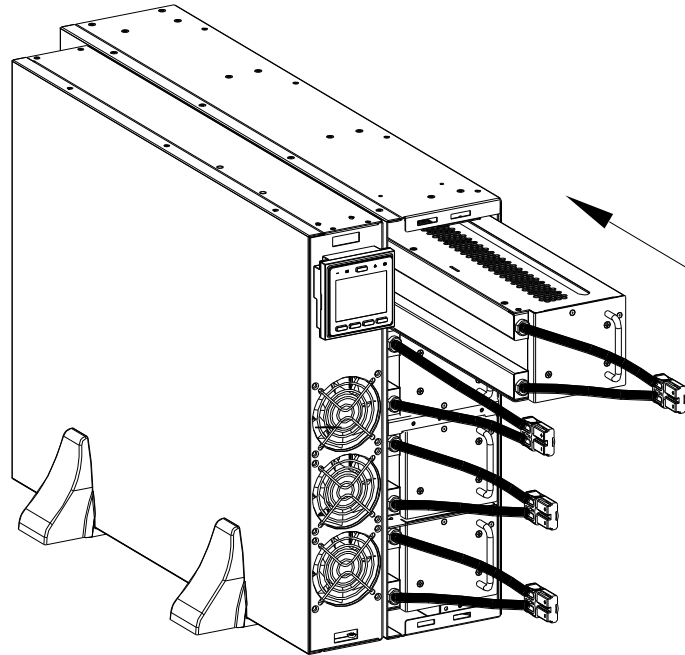

8 Connect four battery modules.

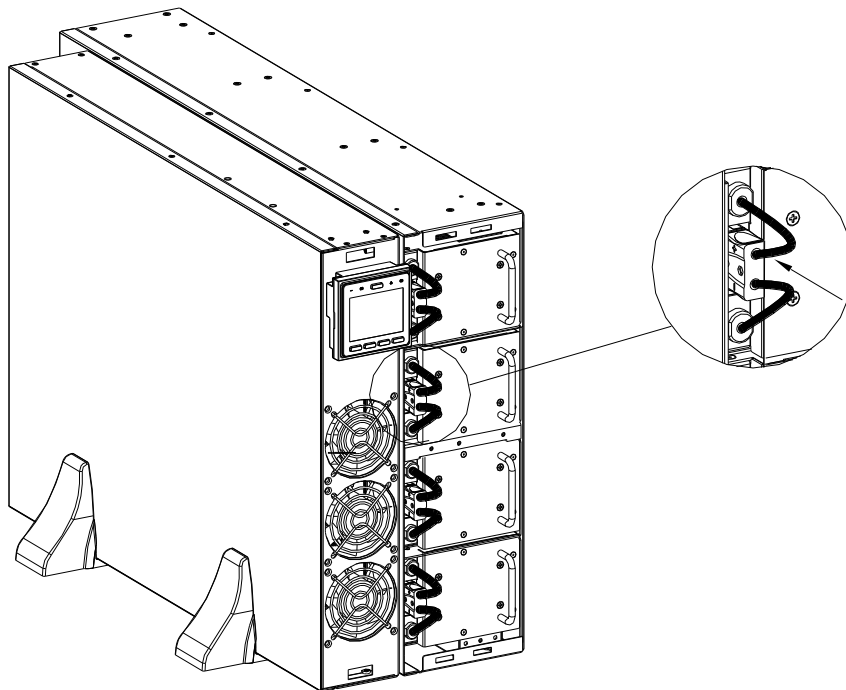

9 Secure the battery compartment door.

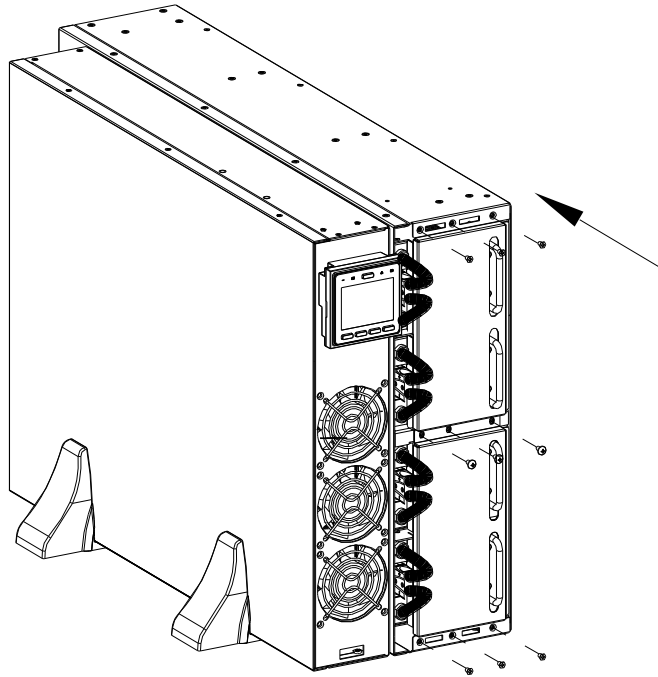

10 Install the front bezels of both the battery pack and UPS module.

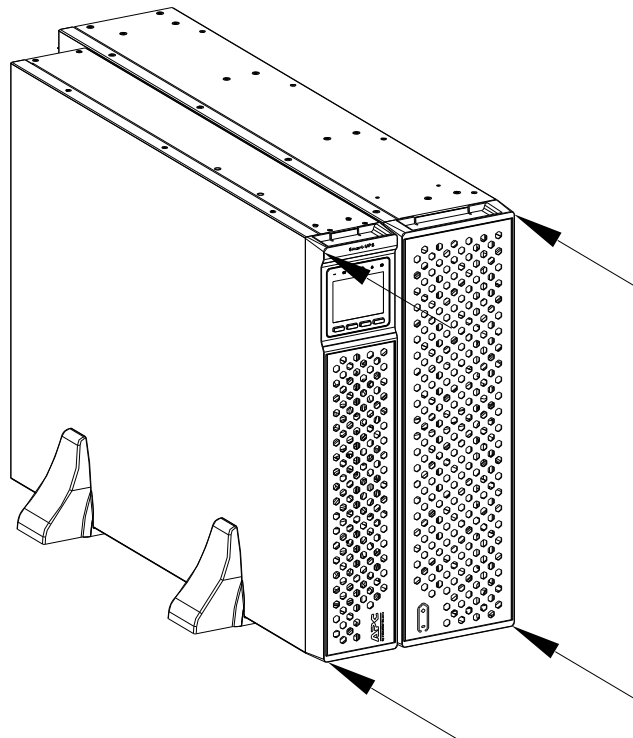

Front Panel Features

1 Front bezel

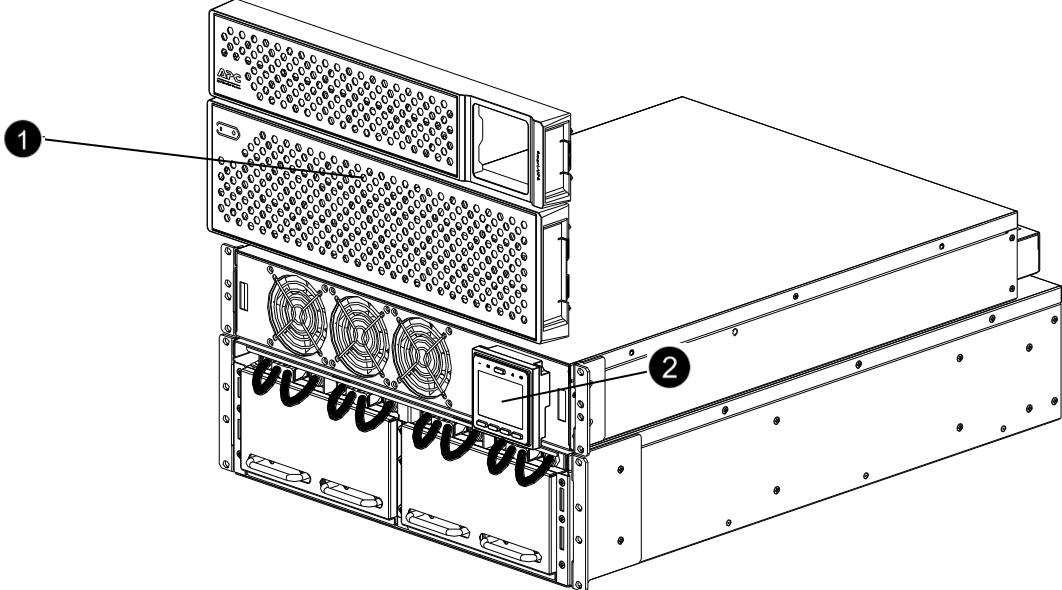

2 LCD module

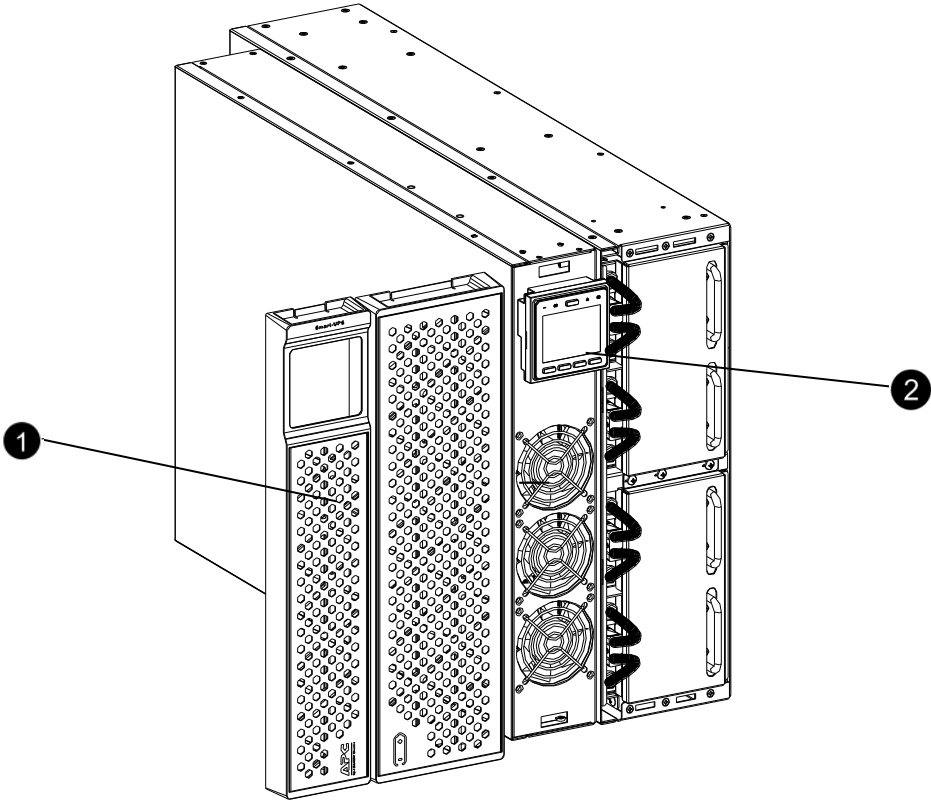

Rear Panel Features

Note: Refer to the table “Key to identify rear panel features” on page 22, that provides a key to the call out numbers for the rear panel graphics depicted in this manual.

This picture is for reference only. The physical object may be different.

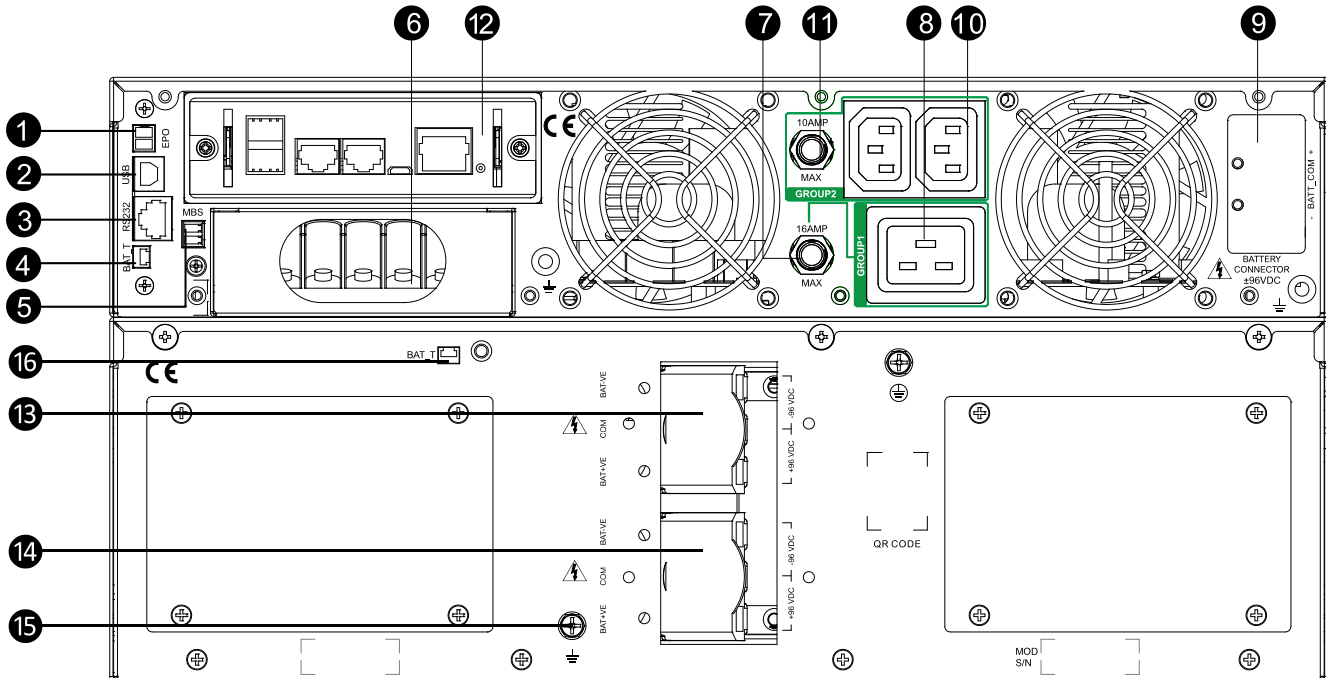

Key to identify rear panel features

1	EPO terminal	The Emergency Power Off (EPO) terminal allows the user to connect the UPS to a central EPO system.
2	USB port	Communication interface only.
3	RS232 port	The serial com port is used to communicate with the UPS. Use only interface kits supplied or approved by APC by Schneider Electric. Any other serial interface cable will be incompatible with the UPS connector. Note: Remote firmware upgrade facility for this UPS model is not available, user needs to use RS232 port for firmware upgrade.
4	BAT_T terminal	Battery temperature sensor. Connect the battery pack temperature sensor cable at 4 and 16.
5	MBS terminal	Maintain bypass signal. Pull out the MBS terminal while carrying out maintenance of the UPS.
6	Hardwire box input/output	Remove the box to connect input and output wires to the hard wire terminal blocks.
7 8	Controllable outlet group 1, with circuit breaker	Connect electronic devices to these outlets. In the event an overload condition occurs, disconnect nonessential equipment. Then reset the circuit breaker. Limit 16 A circuit.
9	Battery input	External Battery input connector.
10 11	Controllable outlet group 2, with circuit breaker	Connect electronic devices to these outlets. In the event an overload condition occurs, disconnect nonessential equipment. Then reset the circuit breaker. Limit 10 A circuit.

12	Smart Slot	The Smart Slot can be used to connect optional management accessories.
13	Battery connector	For connecting to battery input in UPS.
14	Battery connector	For connecting the output from an additional external battery connector.
15	Ground screw	Connect to ground.
16	BAT_T terminal	Battery temperature sensor. Connect the battery pack temperature sensor cable at 4 and 16 .

Wiring Specifications

⚠ CAUTION

RISK OF ELECTRIC SHOCK

- Adhere to all national and local electrical codes.
- Wiring should be performed by a qualified electrician.
- Strain reliefs are not supplied with the unit. 38.1 mm (1 1/2 in) Snap in type strain reliefs are recommended.
- The UPS must be wired into a branch circuit, equipped with a circuit breaker rated as specified in the tables below.
- Actual wire size must comply with required ampacity and national and local electrical codes. Select wire size based on wire insulation, installation method, and environmental conditions.
- Recommended terminal screw torque:
 - 16 mm² or 6 AWG =3.969 Nm (35 lbf-in)
 - 25 mm² or 4 AWG =3.969 Nm (35 lbf-in)

Failure to follow these instructions can result in equipment damage and minor or moderate injury.

System	Wiring	Number of Phases	Voltage	Current Full Load (nominal)	External Input Circuit Breaker Mains (typical)	Wire Size Mains (typical)
SRTG8KXLI	Input	1	220/230/240 Vac	45 A	63A / 2-pole	16 mm ² or 6 AWG
	Output	1	220/230/240 Vac	37 A		16 mm ² or 6 AWG
SRTG10KXLI	Input	1	220/230/240 Vac	55 A	80A / 2-pole	25 mm ² or 4 AWG
	Output	1	220/230/240 Vac	46 A		16 mm ² or 6 AWG

Hardwire the UPS

⚠ WARNING

RISK OF ELECTRIC SHOCK

The output sockets or terminals of the Smart-UPS can be energized when input voltage is applied to the unit.

Failure to follow these instructions can result in death or serious injury and equipment damage.

⚠ CAUTION

RISK OF ELECTRIC SHOCK

- Disconnect the mains input circuit breaker before installing or servicing the UPS or connected equipment.
- Disconnect internal and external batteries before installing or servicing the UPS or connected equipment.
- The UPS contains internal and external batteries that may present a shock hazard even when disconnected from the mains.
- UPS AC hardwired and pluggable outlets may be energized by remote or automatic control at any time.
- Disconnect equipment from the UPS before servicing any equipment.
- Do not use the UPS as a safety disconnect.
- Install appropriate strain reliefs (not supplied). Snap in type strain reliefs are recommended.
- Strip wire insulation 20 mm (.75 inches) to expose the wire. Secure the exposed wire with the lug.
- The terminal blocks use 4 mm, (5/32 inch) Hex screws.

Failure to follow these instructions can result in equipment damage and minor or moderate injury.

❶ Remove three screws from the top of the UPS Input and output housing.

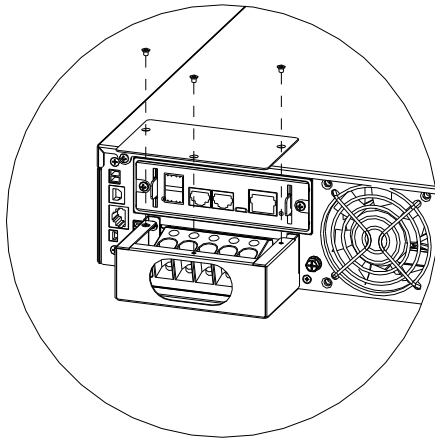

❷ Pass the input and output wires through the opening in the housing. The output ground wire is connected to the outer shell.

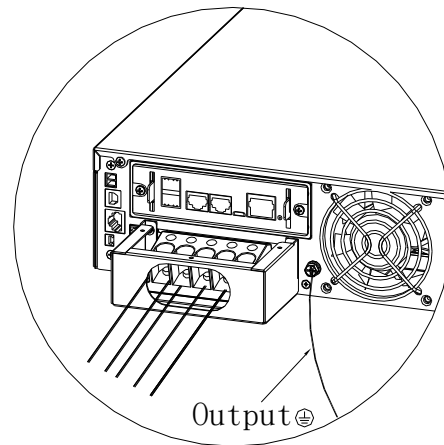

- 3 Connect the input wires to the first 3 terminals (counting from the left) and output wires to the last 2 terminals.

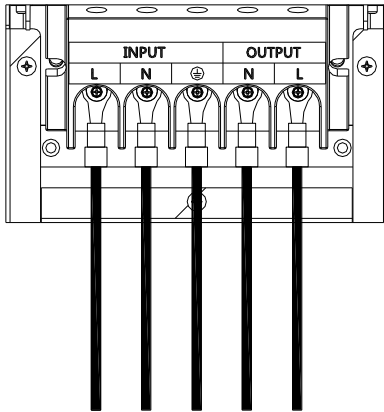

UPS Configuration

Connect Emergency Power Off feature

For instructions on how to connect the Emergency Power Off (EPO) switch, refer to the Operation and Maintenance manual.

Configure controllable outlet groups

The outlets on the UPS are grouped. To configure the controlled outlet features, use the Advanced menus on the display interface and navigate to: Main Menu > Configuration > Outlets > Outlet Group.

UPS Display Interface

1	POWER ON/OFF button
2	UPS status information
3	Operation mode information
4	Load icon
5	Controllable outlet group status icons
6	ESC button
7	OK button
8	UP button
9	DOWN button
10	Battery status icon
11	Bypass LED
12	Error Detected LED
13	On Battery LED
14	Online LED

The icons on the LCD display interface screen may vary depending on the installed firmware version.

	<p>Load icon: The approximate load capacity percentage is indicated by the number of load bar sections illuminated. Each bar represents 20% of the load capacity.</p>
	<p>Mute icon: Indicates the audible alarm is disabled/mute.</p>

UPS status information

The status information field provides key information on the status of the UPS.



The **Main Screen** will scroll through the following parameter.



- **Input Voltage**
- **Input Frequency**
- **Output Voltage**
- **Output Current**
- **Output Frequency**
- **Load Power**
- **Load Apparent Power**
- **Battery Temperature**
- **Battery Charge**
- **Runtime**
- **Environment Temperature**

In the case of a UPS event, status updates will be displayed defining the event or condition that has occurred.

The display screen illuminates amber to indicate a precaution and red to indicate an Alert depending on the severity of the event or condition.

Operation mode icons	
	<p>On-Line mode: The UPS is supplying conditioned mains power to connected equipment.</p>
	<p>Bypass mode: The UPS is in Bypass mode and the connected equipment will receive mains power as long as the input voltage and frequency are within the configured limits.</p>
	<p>Green mode: In Green mode mains power is sent directly to the load. In the event of a mains power outage, there will be an interruption in power to the load of up to 8 ms while the UPS switches to On-Line or Battery mode. When enabling Green mode consideration should be given to devices that may be sensitive to power fluctuations.</p>
	<p>Battery mode: The UPS is supplying battery power to connected equipment.</p>

Controllable outlet group icon	
	Controllable Outlet Group Power Available: The number next to the icon identifies the specific outlet groups that have available power.
	Controllable Outlet Group Power Not Available: The number next to the icon identifies specific outlet groups that do not have available power.

Battery status icons	
	Battery Charge Status: Indicates the battery charge status.
	Battery Charge In Progress: Indicates the battery is charging.

Display interface operation

Use the UP/DOWN buttons to scroll through the options. Press the OK button to accept the selected option. Press the ESC button to return to the previous menu.

Menu overview

The display interface has Standard and Advanced menu screens. The preference for Standard or Advanced menu selections is made during initial installation and can be changed at any time through the Configuration menu.

The Standard menus include the most commonly used options. The Advanced menus provide additional options.

Note: Actual menu screens may differ by model and firmware version. Refer to the UPS Operation Manual for menu configuration details.