



by Schneider Electric

Installation Guide Smart-UPS™ On-Line SRT8K/SRT10K Tower/Rack-Mount 6U

Important Safety Messages

SAVE THESE INSTRUCTIONS - This manual contains important instructions that should be followed during installation and maintenance of the Smart-UPS and batteries.

Read these instructions carefully and look at the equipment to become familiar with the device before trying to install, operate, service or maintain it. The following special messages may appear throughout this bulletin or on the equipment to warn of potential hazards or to call attention to information that clarifies or simplifies a procedure.



The addition of this symbol either to a Danger or Warning product safety label indicates that an electrical hazard exists that will result in personal injury if the instructions are not followed.



This is the safety alert symbol. It is used to alert you to potential personal injury hazards. Obey all safety messages that follow this symbol to avoid possible injury or death.

DANGER

DANGER indicates a hazardous situation which, if not avoided, **will result in** death or serious injury.

WARNING

WARNING indicates a hazardous situation which, if not avoided, **could result in** death or serious injury.

CAUTION

CAUTION indicates a hazardous situation which, if not avoided, **could result in** minor or moderate injury.

NOTICE

NOTICE is used to address practices not related to physical injury.

Product Handling Guidelines



<18 kg
<40 lb



18-32 kg
40-70 lb



32-55 kg
70-120 lb



>55 kg
>120 lb



Safety and General Information

- Adhere to all national and local electrical codes.
- All wiring must be performed by a qualified electrician.
- Do not work alone under hazardous conditions.
- **Changes and modifications to this unit not expressly approved by Schneider Electric IT Corporation could void the warranty.**
- This UPS is intended for indoor use only.
- Do not operate this unit in direct sunlight, in contact with fluids, or where there is excessive dust or humidity.
- Be sure the air vents on the UPS are not blocked. Allow adequate space for proper ventilation.
- For a UPS with a factory installed power cord, connect the UPS power cable directly to a wall outlet. Do not use surge protectors or extension cords.
- The equipment is heavy. Always practice safe lifting techniques adequate for the weight of the equipment.
- The batteries are heavy. Remove the batteries before installing the UPS and external battery packs (XLBPs), in a rack.
- Always install XLBPs at the bottom in rack-mount configurations. The UPS must be installed above the XLBPs.
- Always install peripheral equipment above the UPS in rack-mount configurations.

Deenergizing safety

- The UPS contains internal batteries and may present a shock hazard even when disconnected from AC and DC power.
- The AC and DC output connectors may be energized by remote or automatic control at any time.
- Before installing or servicing the equipment check that the:
 - Input circuit breaker is in the **OFF** position.
 - Internal UPS batteries are removed.
 - XLBP battery modules are disconnected.

Electrical safety

- Do not handle any metallic connector before power has been disconnected.
- For models with a hardwired input, the connection to the branch circuit (mains) must be performed by a qualified electrician.
- 230 V models only: In order to maintain compliance with the EMC directive for products sold in Europe, output cords and network cables attached to the UPS must not exceed 10 meters in length.
- The protective earth conductor for the UPS carries the leakage current from the load devices (computer equipment). An insulated ground conductor is to be installed as part of the branch circuit that supplies input power to the UPS. The conductor must have the same size and insulation material as the grounded and ungrounded branch circuit supply conductors. The conductor will typically be green, with or without a yellow stripe.
- Leakage current for a pluggable, Type A UPS may exceed 3.5 mA when a separate ground terminal is used.
- The UPS input ground conductor must be properly bonded to protective earth at the service panel.
- If the UPS input power is supplied by a separately derived system, the ground conductor must be properly bonded at the supply transformer or motor generator set.

Battery safety

- It is not necessary to ground the battery system. The user has the option of referencing the battery system to chassis ground at either a positive or negative battery terminal.
- Replace batteries with the same number and type of batteries as originally installed in the equipment.

- The battery typically lasts for two to five years. Environmental factors impact battery life. Elevated ambient temperatures, poor quality utility power, and frequent short duration discharges will shorten battery life.
- Replace batteries immediately when the unit indicates battery replacement is necessary.
- Schneider Electric uses Maintenance-Free sealed Lead Acid batteries. Under normal use and handling, there is no contact with the internal components of the battery. Over charging, over heating or other misuse of batteries can result in a discharge of battery electrolyte. Released electrolyte is toxic and may be harmful to the skin and eyes.
- CAUTION: Before installing or replacing the batteries, remove jewelry such as wristwatches and rings. High short circuit current through conductive materials could cause severe burns.
- CAUTION: Do not dispose of batteries in a fire. The batteries may explode.
- CAUTION: Do not open or mutilate batteries. Released material is harmful to the skin and eyes and may be toxic.

Hardwire safety

- Check that all branch circuit (mains) and low voltage (control) circuits are deenergized, and locked out before installing cables or making connections, whether in the junction box or to the UPS.
- Wiring by a qualified electrician is required.
- Check national and local codes before wiring.
- Strain relief is required for all hardwiring (supplied with select products). Snap in type strain reliefs are recommended.
- All openings that allow access to UPS hardwire terminals must be covered. Failure to do so may result in personal injury or equipment damage.
- Select wire size and connectors according to national and local codes.

General information



- The UPS will recognize as many as 10 external battery packs connected to the UPS.
Note: For each XLBP added, increased recharge time will be required.
- The model and serial numbers are located on a small, rear panel label. For some models, an additional label is located on the chassis under the front bezel.
- Always recycle used batteries.
- Recycle the package materials or save them for reuse.

FCC Class A radio frequency warning

This equipment has been tested and found to comply with the limits for a Class A digital device, pursuant to part 15 of the FCC Rules. These limits are designed to provide reasonable protection against harmful interference when the equipment is operated in a commercial environment. This equipment generates, uses, and can radiate radio frequency energy and, if not installed and used in accordance with the instruction manual, may cause harmful interference to radio communications. Operation of this equipment in a residential area is likely to cause harmful interference in which case the user will be required to correct the interference at his own expense.

Package Contents

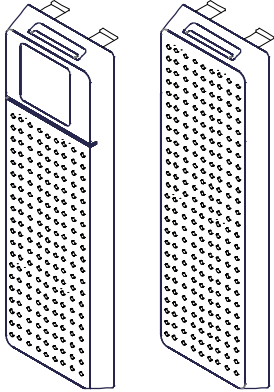
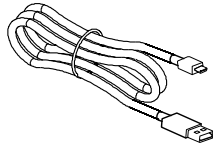
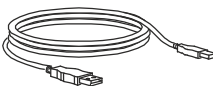
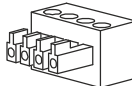
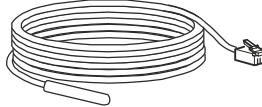
Inspect the contents upon receipt. Notify the carrier and dealer if the unit is damaged.

| Included with all models | | | |
|---|---|---|--|
| <p>Front bezels</p>  | <p>Micro USB cable</p>  <p>USB cable</p>  | <p>EPO Terminal block</p>  <p>Temperature sensor probe</p>  | <p>PowerChute software download guidance</p>  |

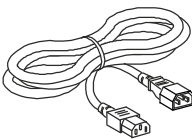
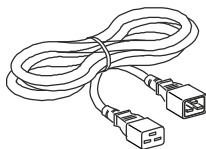
| Included with XLI/XLT-IEC models only | |
|--|--|
| Three output power cords | |
| <p>One C13/C14, 10 A, 2 m</p>  | <p>Two C19/C20, 16 A, 2.5 m</p>  |

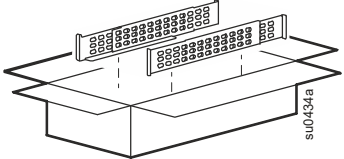
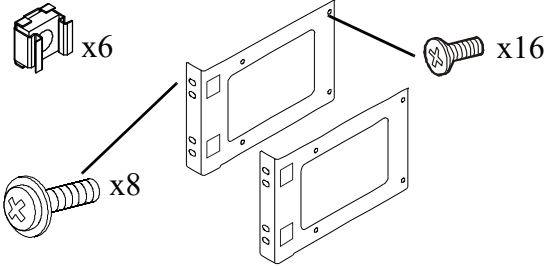
| Included with Rack-Mount models only | |
|--|--|
| <p>Rail Kit with instructions and hardware for installing rails in a rack.</p>  | <ul style="list-style-type: none"> • 2 pairs of rack-mount brackets • 16 flat head screws to secure rack-mount brackets to the UPS • 8 ornamental screws to secure rack-mount brackets to the rails • 6 cage nuts  |

Specifications

For additional specifications refer to the APC by Schneider Electric web site, www.apc.com.

Environmental

| | | |
|---|---|------------------------------|
| Temperature | Operating | 0° to 40° C (32° to 104° F) |
| | Storage | -15° to 45° C (5° to 113° F) |
| Maximum Elevation | Operating | 0 - 3,000 m (0 - 10,000 ft) |
| | Storage | 0 - 15,000 m (50,000 ft) |
| Humidity | 0% to 95% relative humidity, non-condensing | |
| International Protection Code | IP20 | |
| Pollution Degree | 2 | |
| <p>Note: Charge the battery modules every six months during storage. Environmental factors impact battery life. Elevated ambient temperatures, high humidity, poor quality mains power, and frequent short duration discharges will shorten battery life.</p> | | |

Physical

The UPS is heavy. Follow all lifting guidelines.

| | |
|--|---|
| Unit weight without packaging | 111.8 kg (246 lb) |
| Unit weight with packaging | Rack-Mount models: 126.8 kg (279 lb) Tower models: 130 kg (286 lb) |
| Unit dimensions without packaging | 432 mm W x 715 mm D x 263mm H 17 in D x 28.15 in W x 10.35in H |
| Unit dimensions with packaging | 600 mm W x 1000 mm D x 461mm H 23.62 in W x 39.4 in D x 18.2 in H |
| The model and serial numbers are on a small label located on the rear panel. | |

Battery

CAUTION

RISK OF HYDROGEN SULPHIDE GAS AND EXCESSIVE SMOKE

- Replace the battery at least every 5 years.
- Replace the battery immediately when the UPS indicates battery replacement is necessary.
- Replace battery at the end of its service life.
- Replace batteries with the same number and type of batteries as originally installed in the equipment.
- Replace the battery immediately when the UPS indicates a battery overtemperature condition, or when there is evidence of electrolyte leakage. Power off the UPS, unplug it from the AC input, and disconnect the batteries. Do not operate the UPS until the batteries have been replaced.
- *Replace all battery modules (including the modules in External Battery Packs) which are older than one year, when installing additional battery packs or replacing the battery module(s).

Failure to follow these instructions could result in equipment damage and minor or moderate injury.

*Contact APC by Schneider Electric Worldwide Customer Support to determine the age of the installed battery modules.

NOTE: Contact APC by Schneider Electric Worldwide Customer Support when *Battery overtemperature* alert appears on the LCD display.

| | |
|---|---|
| Battery type | Sealed, maintenance-free, Valve Regulated Lead-Acid battery |
| Replacement battery module This UPS has replaceable battery modules. Refer to the appropriate replacement battery user manual for installation instructions. Contact your dealer or go the APC by Schneider Electric web site, www.apc.com for information on replacement batteries. | APCRBC140 |
| Number of battery modules | 4 battery modules |
| Voltage for each battery module Total voltage for the UPS Ah rating | 96 VDC ± 192 VDC 5 Ah per battery module |
| XLBP cable length | 500 mm (19.7 in) |

| Battery module | UPS | XLBP |
|----------------|---|-----------------------|
| APCRBC140 | SRT8KXLx/SRT8KRMXLx/SRT10KXLx/SRT10KRMXLx | SRT192BP2/SRT192RMBP2 |

Specifications continued

Electrical

| | |
|--|-----------------|
| Overvoltage Category | II |
| Applicable power grid power distribution system | TN Power System |
| Applicable Standard* | IEC 62040-1 |

* Applicable only to SRT8KXLI, SRT8KRMXLI, SRT10KXLI, and SRT10KRMXLI models.

CAUTION: To reduce the risk of fire, connect the UPS only to a circuit provided with recommended maximum branch circuit overcurrent protection in accordance with the National Electrical Code, ANSI/NFPA 70 and the Canadian Electrical Code, Part I, C22.1.

| Models | Rating | |
|-----------------|----------------|------------|
| | Online | Green Mode |
| SRT8KXLT | 8 kVA / 8 kW | 8 kVA |
| SRT8KRMXLT | | |
| SRT8KXLT-IEC | | |
| SRT8KRMXLT-IEC | | |
| SRT8KXLI | | |
| SRT8KRMXLI | 10 kVA / 10 kW | 10 kVA |
| SRT10KXLT | | |
| SRT10KRMXLT | | |
| SRT10KXLT-IEC | | |
| SRT10KRMXLT-IEC | | |
| SRT10KXLI | | |
| SRT10KRMXLI | | |

| Output | |
|------------------------|--|
| Output Frequency | 50 Hz/60 Hz \pm 3 Hz |
| Nominal Output Voltage | SRT8KXLI/SRT8KRMXLI/SRT10KXLI/SRT10KRMXLI: 220 Vac / 230 Vac / 240 Vac SRT8KXLT/SRT8KRMXLT/SRT10KXLT/SRT10KRMXLT: 208 Vac / 240 Vac SRT8KXLT-IEC/SRT8KRMXLT-IEC/SRT10KXLT-IEC/SRT10KRMXLT-IEC: 208 Vac / 240 Vac |
| Input | |
| Input Frequency | 40 Hz-70 Hz |
| Nominal Input Voltage | SRT8KXLI/SRT8KRMXLI/SRT10KXLI/SRT10KRMXLI: 220 Vac / 230 Vac / 240 Vac SRT8KXLT/SRT8KRMXLT/SRT10KXLT/SRT10KRMXLT: 208 Vac / 240 Vac SRT8KXLT-IEC/SRT8KRMXLT-IEC/SRT10KXLT-IEC/SRT10KRMXLT-IEC: 208 Vac / 240 Vac |

Remove Battery Modules

CAUTION

RISK OF FALLING EQUIPMENT

- The equipment is heavy. Each battery module weighs 17 kg (37 lb).
- Always practice safe lifting techniques adequate for the weight of the equipment.
- Remove the battery modules before installing the UPS.
- Use the battery module handle to slide the battery modules in or out of the UPS.
- Do not use the battery module handle to lift or carry the battery module.

Failure to follow these instructions can result in equipment damage and minor or moderate injury.

- ❶ Loosen the thumbscrews, and remove the battery compartment doors.

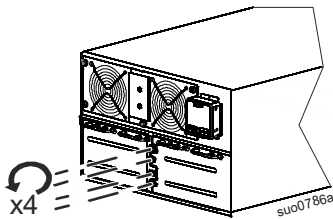

- ❷ Disconnect and remove four battery modules.

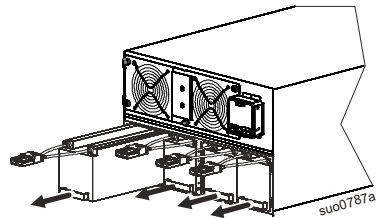

Rack-Mount Installation

Refer to the Rail Kit Installation Guide for instructions on rail installation.

CAUTION

RISK OF FALLING EQUIPMENT

- Practice correct lifting techniques adequate for the weight of the equipment.
- Install XLBPs at the bottom of the rack.
- Install the UPS above the XLBPs.
- Secure the rack-mount brackets to the unit using all of the screws supplied for this purpose.
- Secure the unit in the rack using all of the screws supplied for this purpose.

Failure to follow these instructions could result in equipment damage and minor or moderate injury.

- 1** Secure four brackets to the UPS.
Use six screws in each bracket.

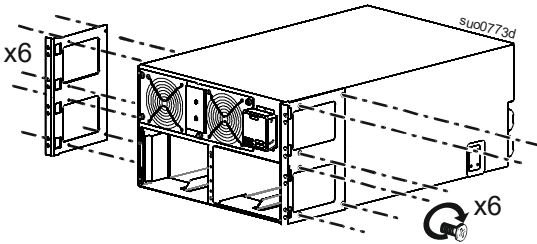

- 2** Install the rails. Follow the rail installation instruction in the rail kit.
Install six cage nuts.

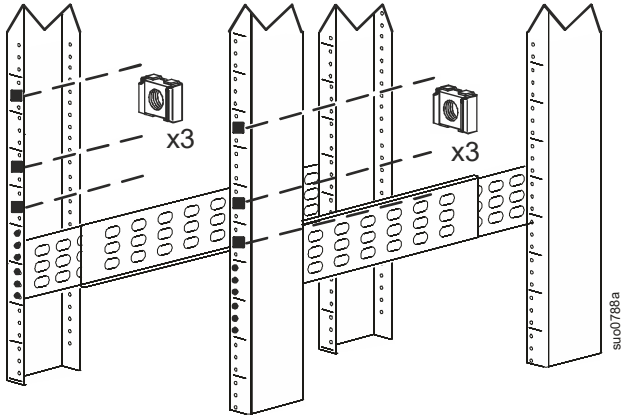

- 3** Rest the UPS on the rail shelves. Slide the UPS into the rack.

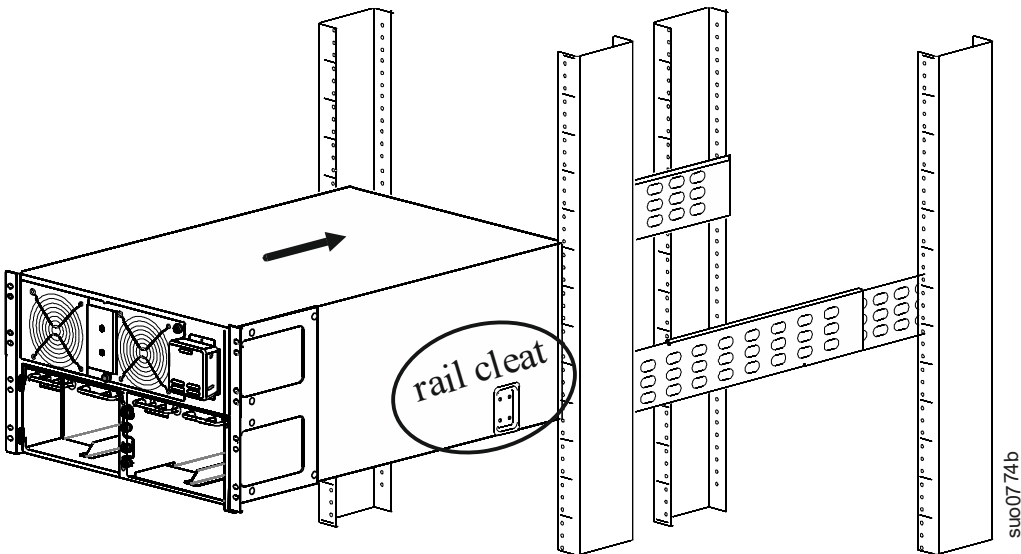

- 4 Secure the UPS to the rack.
Use four screws in each bracket.

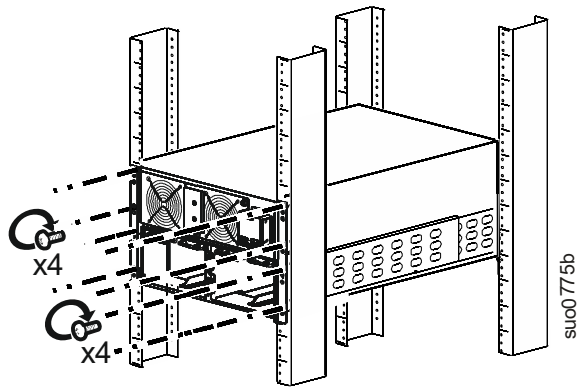

- 5 Install four battery modules.

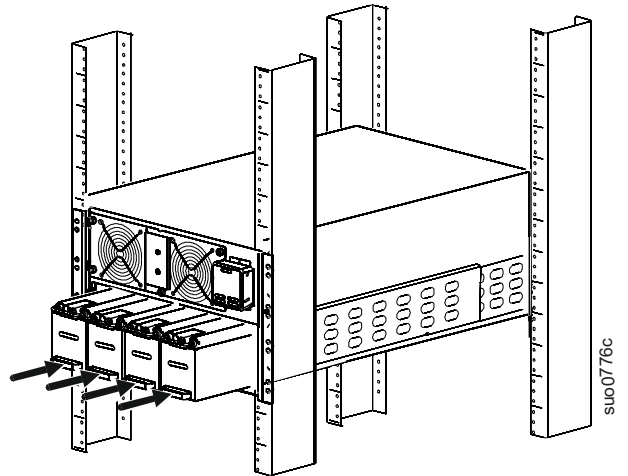

- 6 After the UPS is hardwired to branch circuit mains complete steps 6-8.
Connect all four battery modules.

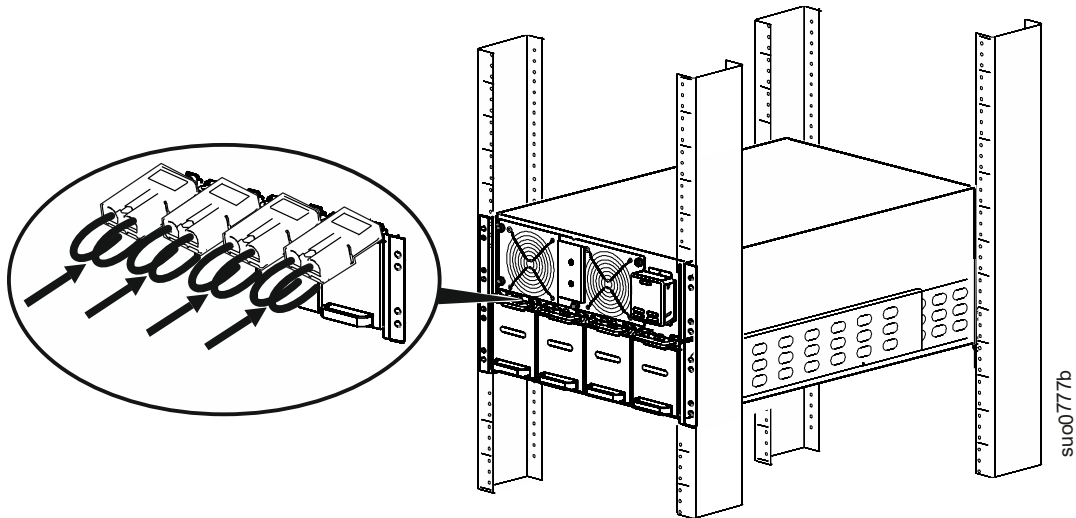

- 7 Reinstall the battery compartment doors.
Tighten the thumbscrews to secure the doors.

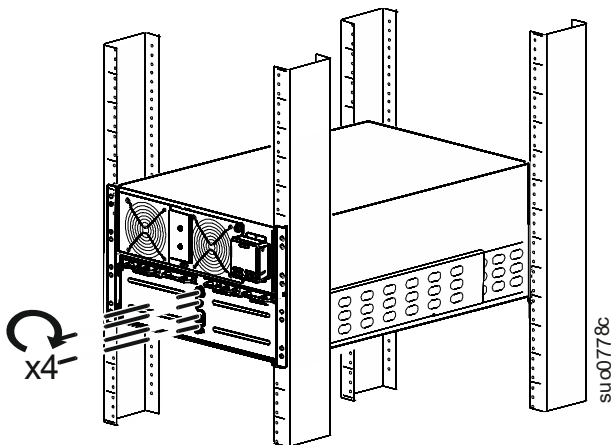

- 8 Install two bezels.

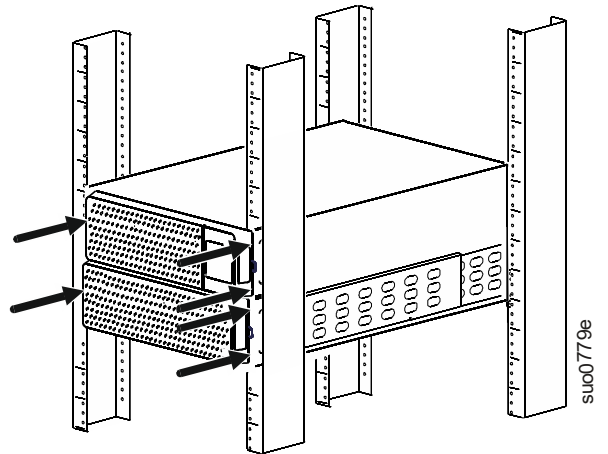

Tower Installation

CAUTION

RISK OF FALLING EQUIPMENT

- The equipment is heavy. Each battery module weighs 17 kg (37 lb).
- Always practice safe lifting techniques adequate for the weight of the equipment.
- Remove the battery modules before installing the UPS.
- Use the battery module handle to slide the battery modules in or out of the UPS.
- Do not use the battery module handle to lift or carry the battery module.

Failure to follow these instructions can result in equipment damage and minor or moderate injury

❶ Install four battery modules.

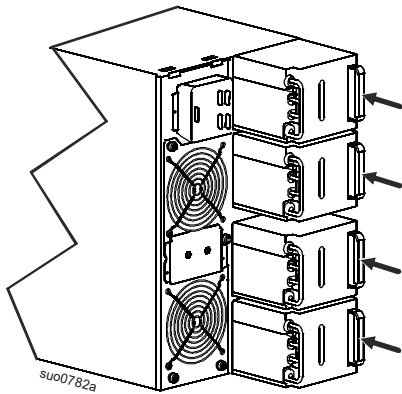

❷ After the UPS is hardwired to branch circuit mains, complete steps 2-5. Connect all four battery modules.

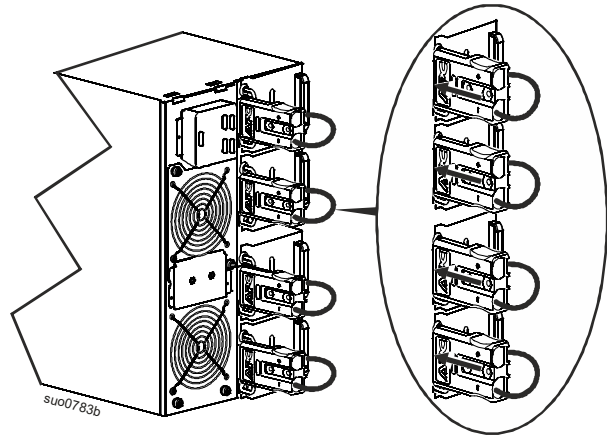

❸ Reinstall the battery compartment doors. Tighten the thumbscrews to secure the doors.

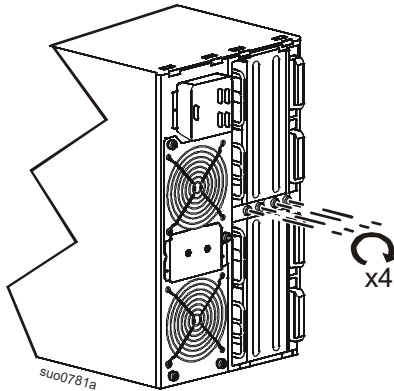

❹ Rotate the display panel clockwise one quarter turn.

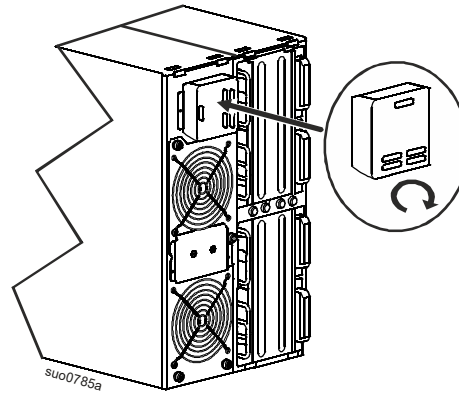

- 5 Install two bezels.

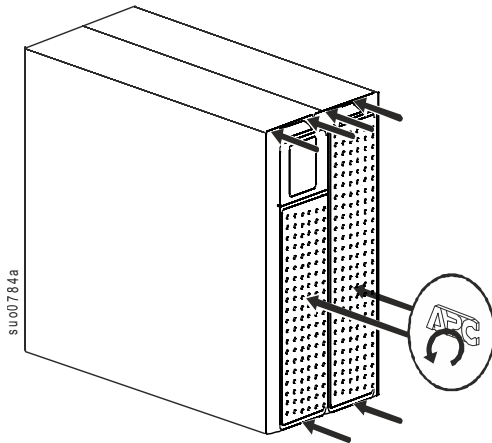

Front Panel Features

- 1 Display interface panel
- 2 UPS battery compartment doors x2
- 3 UPS battery connectors x4
- 4 Bezels x2

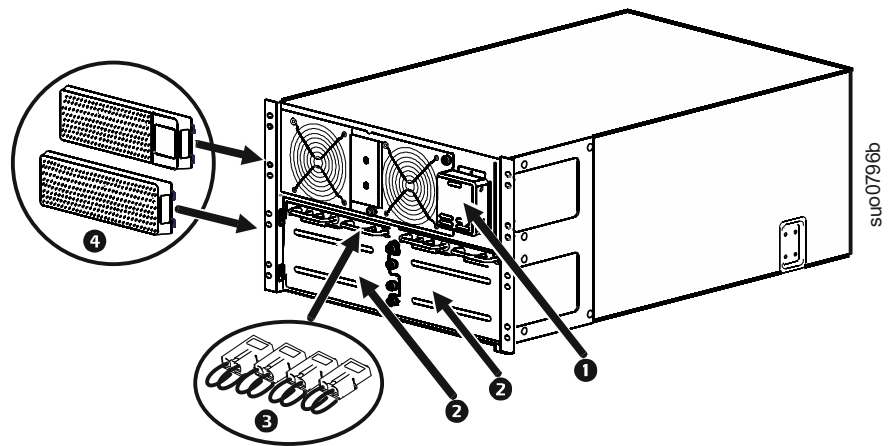

Rear Panel Features

Note: Refer to the table “Wiring Specifications” on page 16, that provides a key to the callout numbers for the rear panel graphics depicted in this manual.

SRT8KXLT/SRT8KRMXLT/SRT10KXLT/SRT10KRMXLT

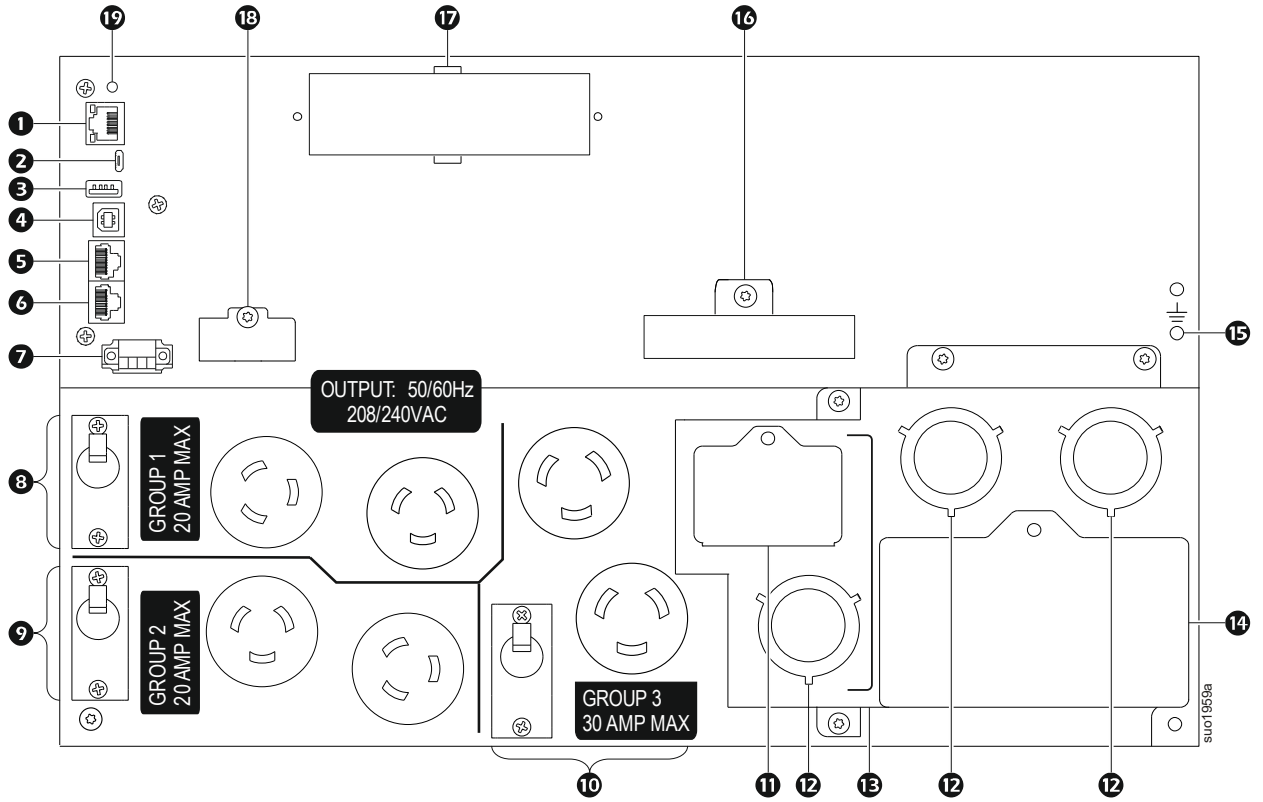

SRT8KXLT-IEC/SRT8KRMXLT-IEC/SRT10KXLT-IEC/SRT10KRMXLT-IEC

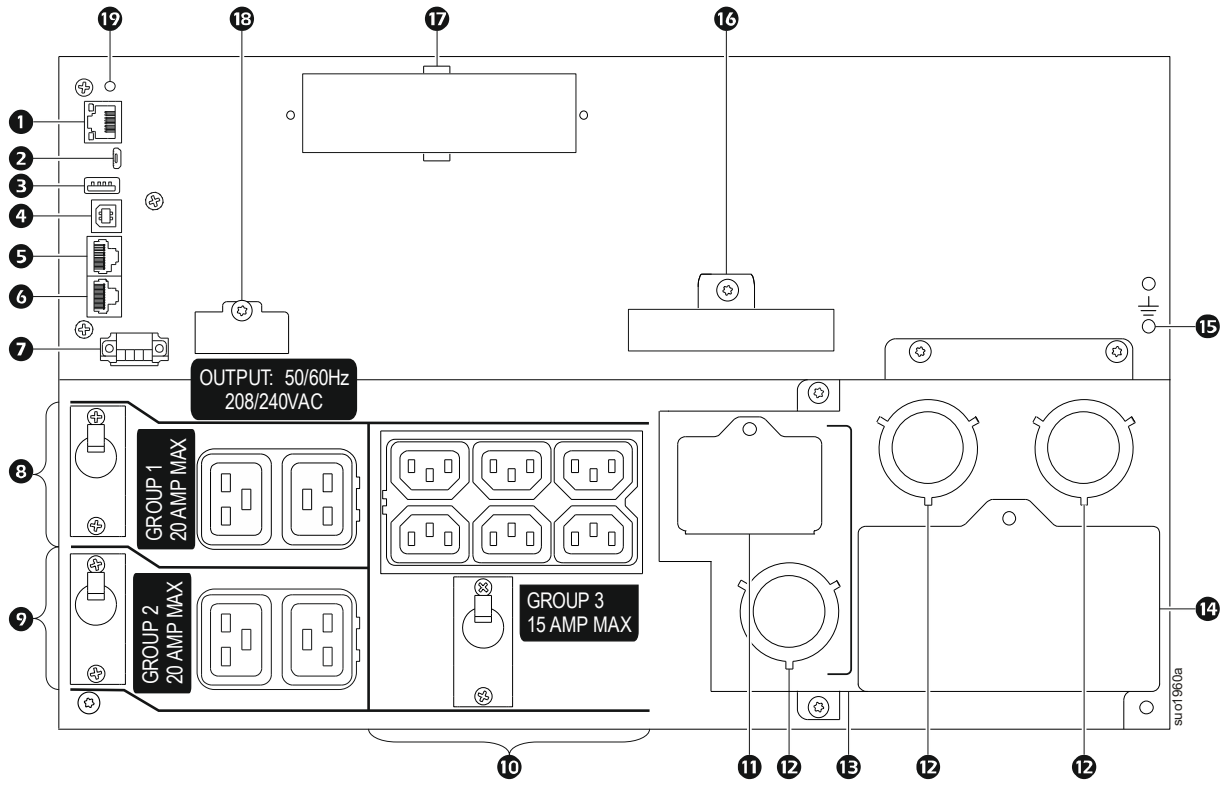

SRT8KXLI/SRT8KRMXLI/SRT10KXLI/SRT10KRMXLI

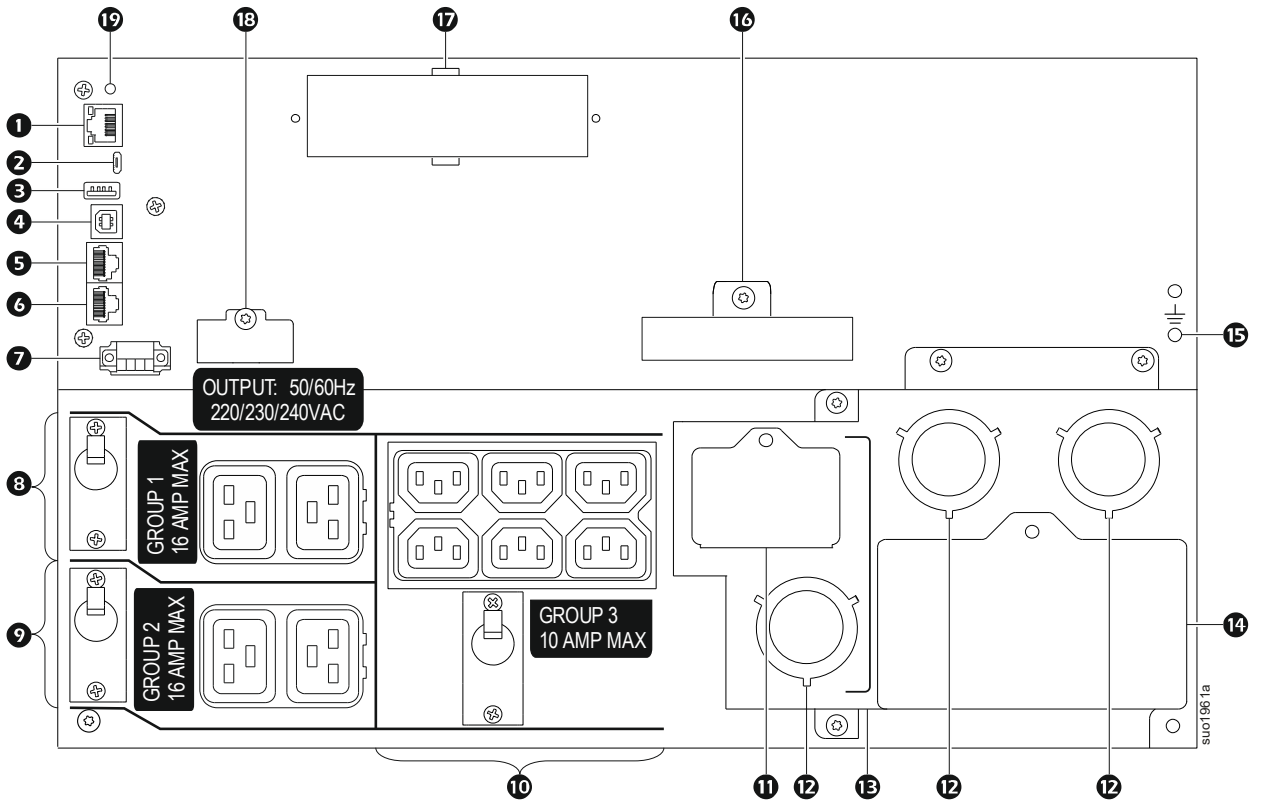

Key to identify rear panel features

| | | |
|---|--|--|
| ① | Network port | Use the Network port to connect the UPS to the network. |
| ② | Console port | Use the Console port to configure the network management features. |
| ③ | USB port | Connector for a USB flash drive. |
| ④ | UPS USB port | The USB port is used to connect either a server for native operating system communications, or for software to communicate with the UPS. Note: Serial and USB communication should not be used simultaneously. Use either the Serial Com or the USB port. |
| ⑤ | Universal I/O port | Use to connect: <ul style="list-style-type: none"> • Temperature sensor AP9335T (supplied) • Temperature/humidity sensor AP9335TH (not supplied) • Relay input/output connector AP9810 (not supplied), supports two input contacts and one output relay |
| ⑥ | Serial Com | The Serial Com port is used to communicate with the UPS. Use only interface kits supplied or approved by Schneider Electric. Any other serial interface cable will be incompatible with the UPS connector. |
| ⑦ | EPO terminal | The Emergency Power Off (EPO) terminal allows the user to connect the UPS to a central EPO system. |
| ⑧ | Controllable outlet group 1, with circuit breaker | Connect electronic devices to these outlets. In the event an overload condition occurs, disconnect nonessential equipment. Then reset the circuit breaker. |
| ⑨ | Controllable outlet group 2, with circuit breaker | Connect electronic devices to these outlets. In the event an overload condition occurs, disconnect nonessential equipment. Then reset the circuit breaker. |
| ⑩ | Controllable outlet group 3, with circuit breaker | Connect electronic devices to these outlets. In the event an overload condition occurs, disconnect nonessential equipment. Then reset the circuit breaker. |
| ⑪ | AC output inspection panel | Remove the panel to inspect the output terminal block wiring configuration. The terminal block is located behind the inspection cover. Refer to “Wiring Specifications” on page 16 for hardwire specifications. |
| ⑫ | AC hardwire knockouts | Remove the 38.1 mm (1.5 in) knockout panels for AC input and output hardwiring. Install appropriate strain reliefs (not supplied). |
| ⑬ | Hardwire box input/output | Remove the box to connect input and output wires to the hardwire terminal blocks. |
| ⑭ | AC input inspection panel | Remove the panel to inspect the input terminal block wiring configuration. The terminal block is located behind the inspection cover. Refer to “Wiring Specifications” on page 16 for hardwire specifications. |
| ⑮ | Chassis ground screws | The UPS and XLBPs have ground screws for connecting the ground leads. Prior to connecting a ground lead, disconnect the UPS from mains power. |
| ⑯ | External battery power and communication connectors | Use the external battery power and communication cables to connect the UPS and XLBP. XLBPs provide extended runtime during power outages. The UPS will automatically recognize up to 10 external battery packs. |
| ⑰ | SmartSlot | The SmartSlot can be used to connect optional management accessories. |
| ⑱ | PRL COMM port | This port is not used with these products. |
| ⑲ | Reset button | Use the Reset button to restart the Network Management Interface. Note: A restart of the Network Management Interface does not affect UPS operation. |

Wiring Specifications



CAUTION

RISK OF ELECTRIC SHOCK

- Adhere to all national and local electrical codes.
- Wiring should be performed by a qualified electrician.
- Use Snap-In strain relief(s) provided with the unit.
- The UPS must be wired into a branch circuit, equipped with a circuit breaker rated as specified in the tables below.
- Actual wire size must comply with required amp capacity and national and local electrical codes.
- Recommended input terminal screw torque: 16 lbf-in (2 Nm).

Failure to follow these instructions can result in equipment damage and minor or moderate injury

Single Feed

| System | Wiring | Number of Phases | Voltage | Current Full Load (nominal) | External Input Circuit Breaker Mains (typical) | Wire Size Mains (typical) |
|-----------|--------|------------------|-----------------|-----------------------------|--|--------------------------------|
| SRT8KXLT | Input | 1 | 208/240 Vac | 47 A | 60 A / 2-pole | 16 mm ² or 6 AWG |
| | Output | 1 | 208/240 Vac | 40 A | | 16 mm ² or 6 AWG |
| SRT10KXLT | Input | 1 | 208/240 Vac | 56 A | 70 A / 2-pole | 25 mm ² or 4 AWG |
| | Output | 1 | 208/240 Vac | 49 A | | 16 mm ² or 6 AWG |
| SRT8KXLI | Input | 1 | 220/230/240 Vac | 44 A | 63 A / 2-pole | 16 mm ² or 6 AWG |
| | Output | 1 | 220/230/240 Vac | 38 A | | 16 mm ² or 6 AWG |
| | Input | 3 | 380/400/415 Vac | 15 A 44 A* | 63 A / 4-pole | 16 mm ² or 6 AWG |
| | Output | 1 | 220/230/240 Vac | 38 A | | 16 mm ² or 6 AWG |
| SRT10KXLI | Input | 1 | 220/230/240 Vac | 54 A | 80 A / 2-pole | 25 mm ² 4 AWG |
| | Output | 1 | 220/230/240 Vac | 47 A | | 16 mm ² or 6 AWG |
| | Input | 3 | 380/400/415 Vac | 18 A 54 A* | 80 A / 4-pole | 25 mm ² or 4 AWG |
| | Output | 1 | 220/230/240 Vac | 47 A | | 16 mm ² or 6 AWG |

* Phase 1 (L1) current while in bypass mode

Wiring Specifications

| Dual Feed | | | | | | | | |
|-----------|--------|------------------|-----------------|-----------------------------|--|---|--------------------------------|--------------------------------|
| System | Wiring | Number of Phases | Voltage | Current Full Load (nominal) | External Input Circuit Breaker Mains (typical) | External Input Circuit Bypass Mains (typical) | Wire Size Mains (typical) | Wire Size Bypass (typical) |
| SRT8KXLI | Input | 1 | 220/230/240 Vac | 44 A | 63 A / 2-pole | 63 A / 2-pole | 16 mm ² or 6 AWG | 16 mm ² or 6 AWG |
| | Input | 3 | 380/400/415 Vac | 15 A | 20 A / 4-pole | 63 A / 2-pole | 4 mm ² or 12 AWG | 16 mm ² or 6 AWG |
| | Output | 1 | 220/230/240 Vac | 38 A | | | 16 mm ² or 6 AWG | 16 mm ² or 6 AWG |
| SRT10KXLI | Input | 1 | 220/230/240 Vac | 54 A | 80 A / 2-pole | 80 A / 2-pole | 25 mm ² or 4 AWG | 25 mm ² or 4 AWG |
| | Input | 3 | 380/400/415 Vac | 18 A | 25 A / 4-pole | 80 A / 2-pole | 4 mm ² or 12 AWG | 25 mm ² or 4 AWG |
| | Output | 1 | 220/230/240 Vac | 47 A | | | 16 mm ² or 6 AWG | 16 mm ² or 6 AWG |

Hardwire the UPS

⚠ CAUTION

RISK OF ELECTRIC SHOCK

- Adhere to all national and local electrical codes.
- Wiring must be performed by a qualified electrician.
- Disconnect the mains power, internal and external batteries before installing or servicing the UPS or connected equipment.
- The AC and DC output connectors may be energized by remote or automatic control at any time.
- Disconnect equipment from the UPS before servicing any equipment.
- Do not use the UPS as a safety disconnect.
- Install 1 1/2 in (38.1mm) Snap-In strain reliefs.
- Strip wire insulation 20 mm (.75 inches) to expose the wire. Secure the exposed wire with the lug.
- The jumpers use T25 Torx screws.
- The terminal blocks use 4 mm, (5/32 inch) Hex screws.

Failure to follow these instructions could result in minor or moderate injury.

Remove the five #2 Phillips screws that secure the hardwire box to the UPS.
Pull the hardwire box out of the UPS.

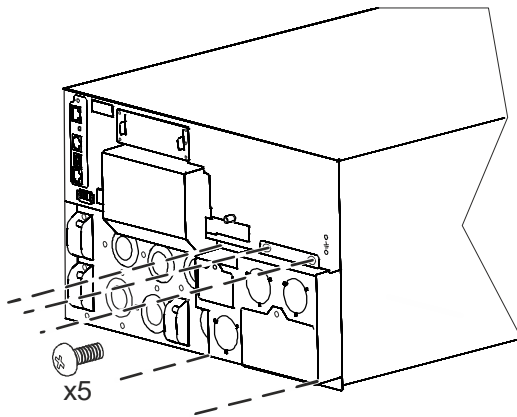

Install strain reliefs (not supplied), for the hardwire configuration that will be used.

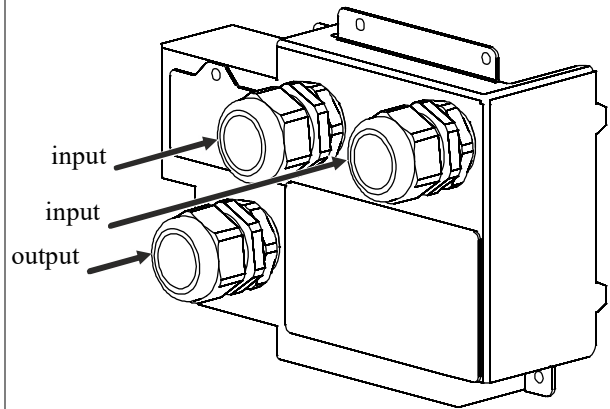

Input hardware

XLI single phase, single feed

Leave bypass and phase jumpers in place.

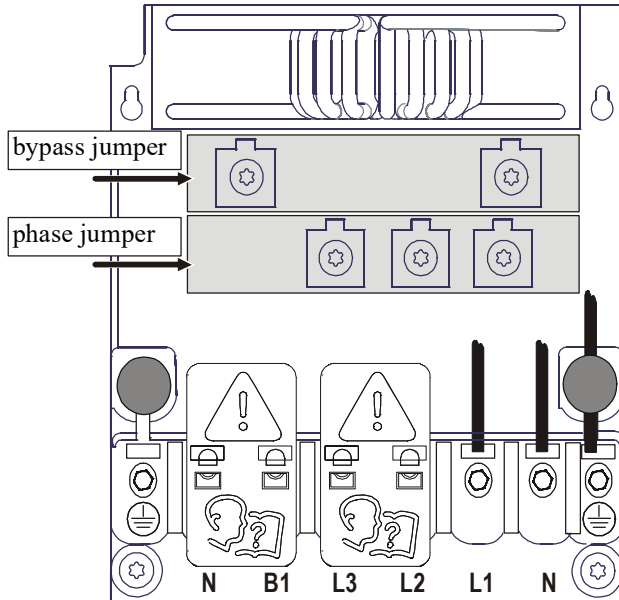

XLI single phase, dual feed

Remove bypass jumper.

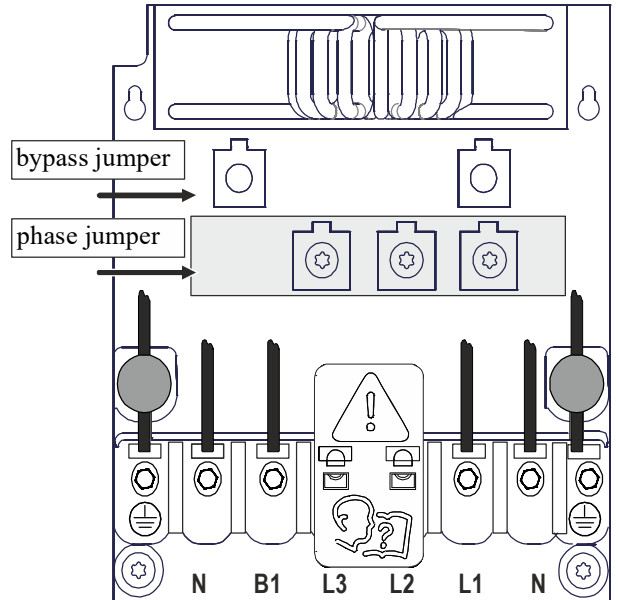

XLI three phase, single feed

Remove phase jumper.

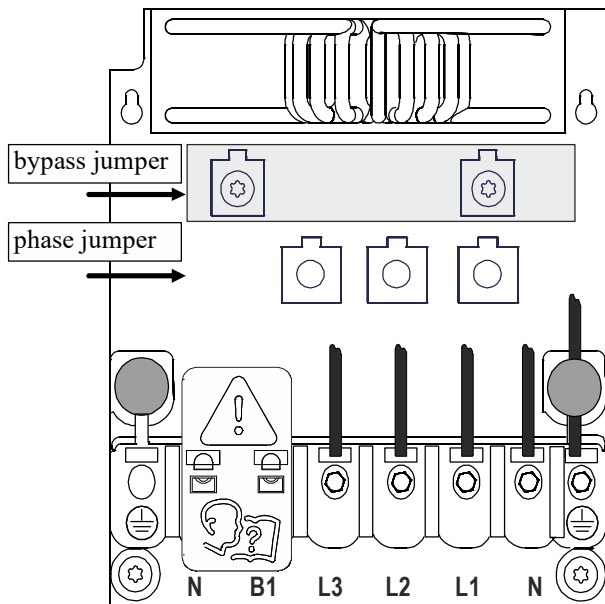

XLI three phase, dual feed

Remove bypass and phase jumpers.

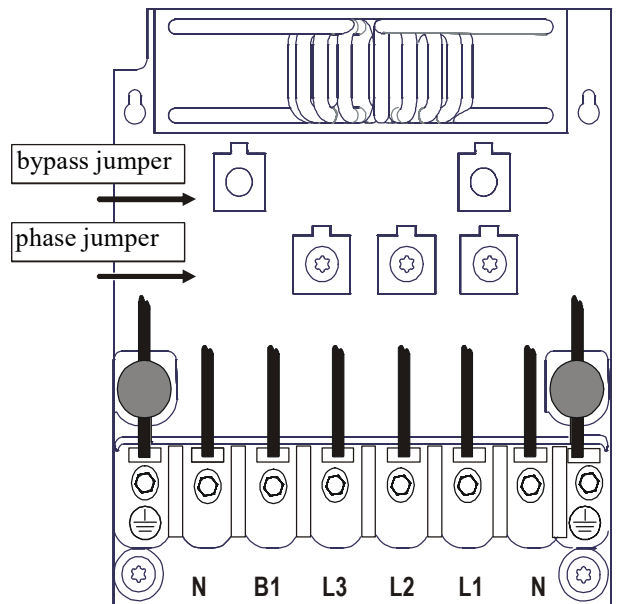

Input hardwire continued

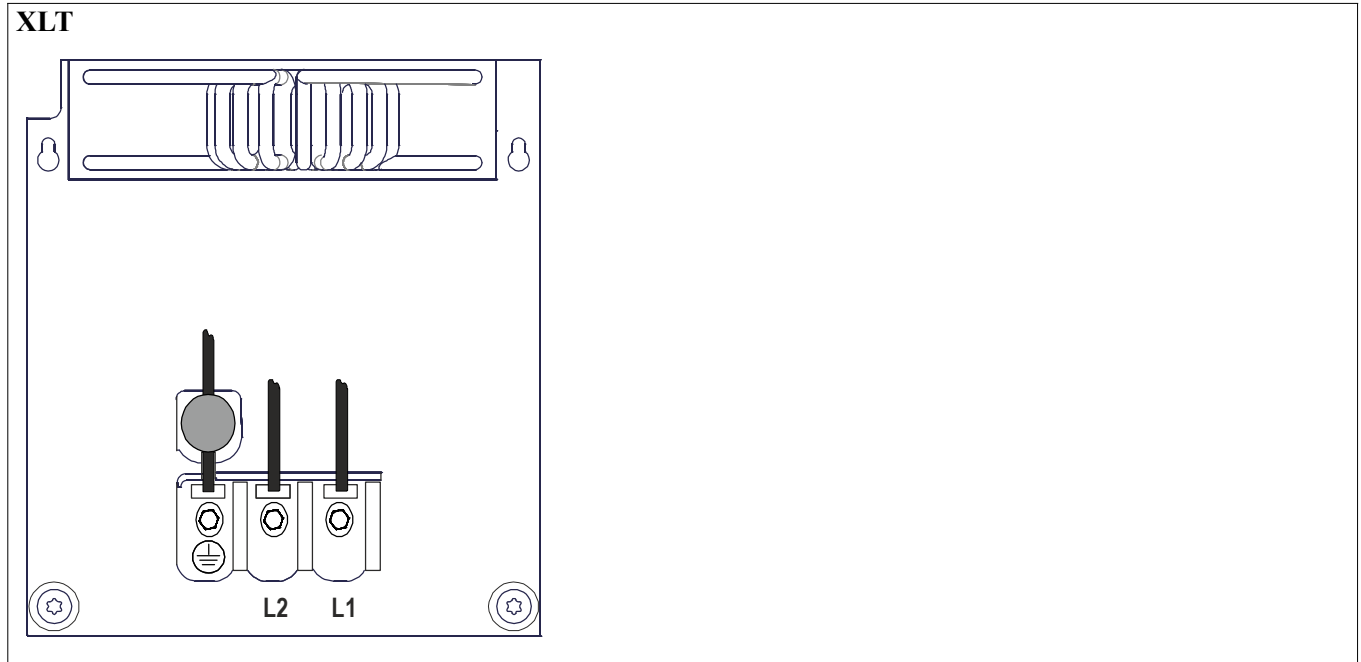

Output hardwire

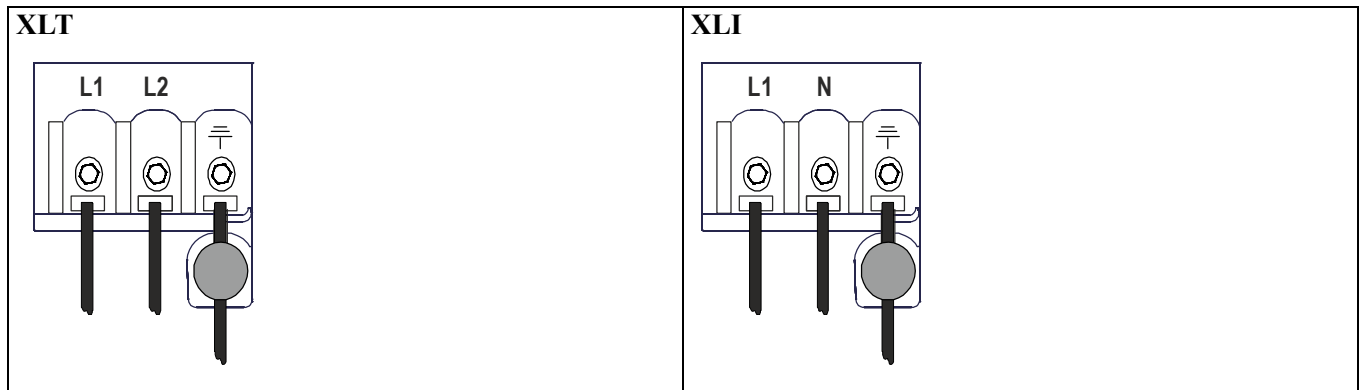

Reinstall the hardwire box in the UPS.
Secure the hardwire box with the five screws previously removed.

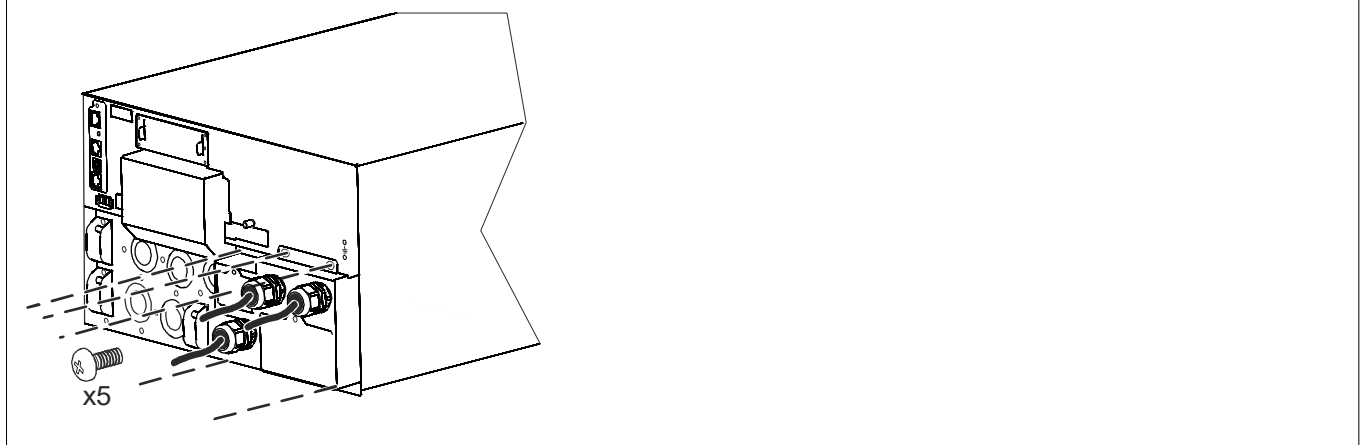

UPS Configuration

Connect Emergency Power Off feature

For instructions on how to connect the Emergency Power Off (EPO) switch, refer to the Operation and Maintenance manual. To download the Operation and Maintenance manual

1. Go to <https://www.apc.com/us/en/country-selector>.
2. Select your location.
3. Type “Operation and Maintenance Manual <Model Name>” in the search bar.

Configure controllable outlet groups



The outlets on the UPS are grouped. To configure the controlled outlet features, use the **Advanced** menus on the display interface and navigate to: **Main Menu > Configuration > Outlets > Outlet Group**.

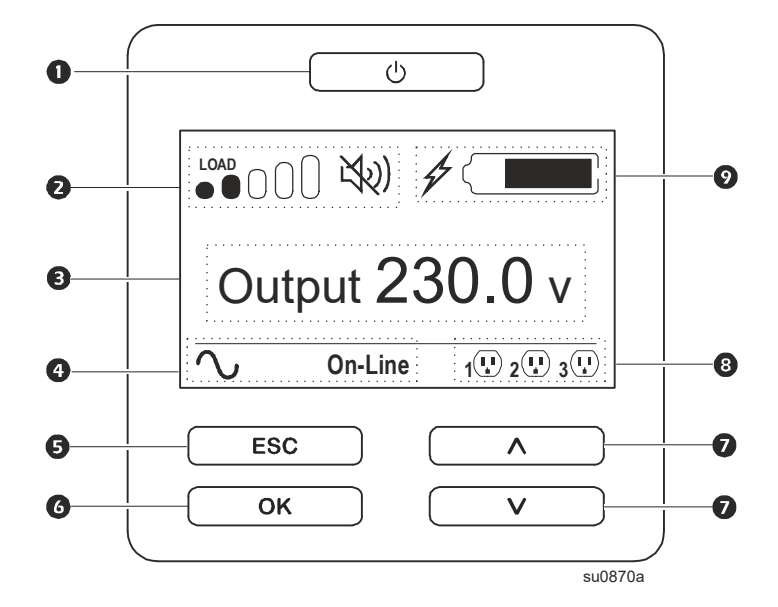







UPS Display Interface

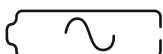

| | |
|---|---|
| <p>1 POWER ON/OFF button</p> <p>Button illumination indications:</p> <ul style="list-style-type: none"> • No illumination, the UPS and the output power are off. • White illumination, the UPS and the output power are on. • Red illumination, the UPS is on and the output power is off. |  <p>The diagram shows a rectangular display interface with a power button at the top (1). Below it is a status bar (2) containing a load indicator (LOAD), a mute icon, and a battery icon. The main display area (3) shows 'Output 230.0 v'. Below the display are icons for a sine wave (4), 'On-Line' status, and three outlet status icons (8). At the bottom are two rows of buttons: 'ESC' and '^' (5), and 'OK' and 'v' (6). The right side of the interface has a vertical column of buttons (7) and a battery status icon (9). The model number 'su0870a' is printed at the bottom right.</p> |
| <p>2 Load icon Disable/mute audible alarm icon</p> | |
| <p>3 UPS status information</p> | |
| <p>4 Operation mode icons</p> | |
| <p>5 ESCAPE button</p> | |
| <p>6 OK button</p> | |
| <p>7 UP/DOWN buttons</p> | |
| <p>8 Controllable outlet group status icons</p> | |
| <p>9 Battery status icons</p> | |

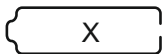
UPS Display Interface operation

Use the UP/DOWN buttons to scroll through the options. Press the OK button to accept the selected option. Press the ESC button to return to the previous menu.

| | |
|--|---|
| The icons on the LCD display interface screen may vary depending on the installed firmware version. | |
|  | Load icon: The approximate load capacity percentage is indicated by the number of load bar sections illuminated. Each bar represents 16% of the load capacity. |
|  | Mute icon: Indicates the audible alarm is disabled/mute. |
| <h3>UPS Status Information</h3> <p>The status information field provides key information on the status of the UPS. The Standard menu will allow the user to select one of the five screens listed below. Use the UP/DOWN buttons to scroll through the screens. The Advanced menu will scroll through the five screens automatically.</p> <ul style="list-style-type: none"> • Input Voltage • Output Voltage • Output Frequency • Load • Runtime <p>In the case of a UPS event, status updates will be displayed defining the event or condition that has occurred. The display screen illuminates amber to indicate a Message and red to indicate an Alert depending on the severity of the event or condition.</p> | |

| | |
|---|--|
| Operation Mode Icons | |
|  | On-Line mode: The UPS is supplying conditioned mains power to connected equipment. |
|  | Bypass mode: The UPS is in Bypass mode and the connected equipment will receive mains power as long as the input voltage and frequency are within the configured limits. |
|  | <p>Green mode: When in Green mode mains power is sent directly to the load.</p> <p>In the event of a mains power outage, there will be an interruption in power to the load of up to 10 ms while the UPS switches to On-Line or Battery mode.</p> <p>When enabling Green mode consideration should be given to devices that may be sensitive to power fluctuations.</p> |
| UPS Status Icon | |
|  | Battery mode: The UPS is supplying battery power to connected equipment. |
|  | The UPS has detected an internal fault with the battery. Follow the instructions on the screen. |
|  | The UPS has detected a critical fault with the battery. The battery is at the end of its life and has to be replaced. |
|  | Indicates a UPS alert that requires attention. |
| Controllable Outlet Group Icons | |
|  | <p>Controllable Outlet Group Power Available: The number next to the icon identifies the specific outlet groups that have available power.</p> <p>Flashing icon indicates the outlet group is turning from OFF to ON with delay.</p> |
|  | <p>Controllable Outlet Group Power Not Available: The number next to the icon identifies specific outlet groups that do not have available power.</p> <p>Flashing icon indicates the outlet group is turning from ON to OFF with delay.</p> |

| Battery Status Icons | |
|---|---|
|  | Battery Charge Status: Indicates the battery charge status. |
|  | Battery Charge In Progress: Indicates the battery is charging. |

Menu overview

The display interface has **Standard** and **Advanced** menu screens. The preference for **Standard** or **Advanced** menu selections is made during initial installation and can be changed at any time through the **Configuration** menu.

The **Standard** menus include the most commonly used options.

The **Advanced** menus provide additional options.

Note: Actual menu screens may differ by model and firmware version.

Refer to the UPS Operation Manual for menu configuration details.

LCD display interface angle adjustment

The angle of the LCD display interface can be adjusted for ease in viewing the displayed messages.

1. Remove the front bezel.
2. Locate the button on the bottom of the display interface panel.
3. Press the button and slide the bottom of the LCD display interface screen out. An audible click will be heard when the screen reaches the maximum angle.

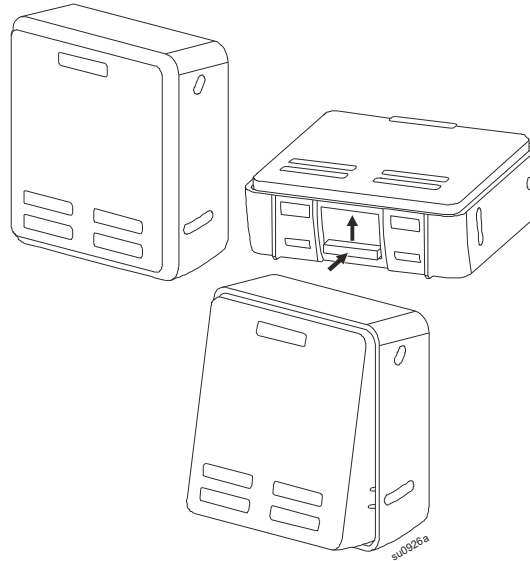

Location of QR Code for User Document

The QR Code for downloading the user documents is located behind the front bezel.

1. Open the front bezel.
2. Scan the QR Code.
3. Click on “Documentation”.
4. Click on “Asset Lifecycle Documents”.
5. Click on the desired document.

