

# Easy UPS 3M

**120-200 kVA 400 V and 60-100 kVA 208 V for External Batteries**

## Installation

Latest updates are available on the Schneider Electric website

11/2024

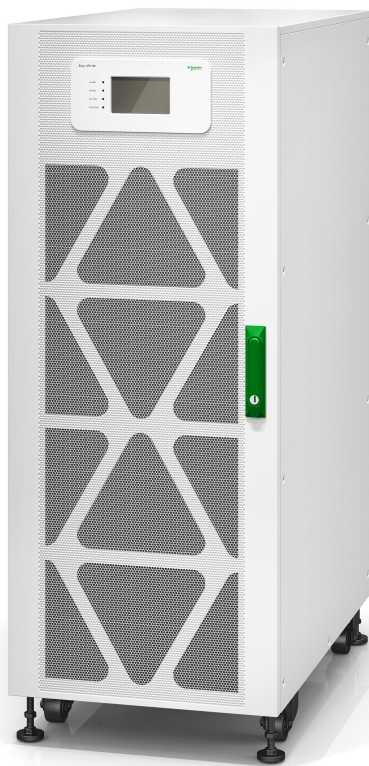

# Legal Information

The information provided in this document contains general descriptions, technical characteristics and/or recommendations related to products/solutions.

This document is not intended as a substitute for a detailed study or operational and site-specific development or schematic plan. It is not to be used for determining suitability or reliability of the products/solutions for specific user applications. It is the duty of any such user to perform or have any professional expert of its choice (integrator, specifier or the like) perform the appropriate and comprehensive risk analysis, evaluation and testing of the products/solutions with respect to the relevant specific application or use thereof.

The Schneider Electric brand and any trademarks of Schneider Electric SE and its subsidiaries referred to in this document are the property of Schneider Electric SE or its subsidiaries. All other brands may be trademarks of their respective owner.

This document and its content are protected under applicable copyright laws and provided for informative use only. No part of this document may be reproduced or transmitted in any form or by any means (electronic, mechanical, photocopying, recording, or otherwise), for any purpose, without the prior written permission of Schneider Electric.

Schneider Electric does not grant any right or license for commercial use of the document or its content, except for a non-exclusive and personal license to consult it on an "as is" basis.

Schneider Electric reserves the right to make changes or updates with respect to or in the content of this document or the format thereof, at any time without notice.

**To the extent permitted by applicable law, no responsibility or liability is assumed by Schneider Electric and its subsidiaries for any errors or omissions in the informational content of this document, as well as any non-intended use or misuse of the content thereof.**

## Access to Your Product Manuals Online

### Find the UPS Manuals, Submittal Drawings, and Other Documentation for Your Specific UPS Here:

In your web browser, type in <https://www.go2se.com/ref=> and the commercial reference for your product.

Example: <https://www.go2se.com/ref=E3MUPS60KHS>

### Find the UPS Manuals, Relevant Auxiliary Product Manuals, and Option Manuals Here:

Scan the code to go to the Easy UPS 3M online manual portal:

**IEC (380/400/415 V)**



<https://www.productinfo.schneider-electric.com/easyups3m/>

Here you can find your UPS installation manual, UPS operation manual, and UPS technical specifications, and you can also find installation manuals for your auxiliary products and options.

This online manual portal is available on all devices and offers digital pages, search functionality across the different documents in the portal, and PDF download for offline use.

### Learn More About the Easy UPS 3M Here:

Go to <https://www.se.com/ww/en/product-range/66001> to learn more about this product.

# Table of Contents

<b>Important Safety Instructions — SAVE THESE</b>	
<b>INSTRUCTIONS</b>	7
Electromagnetic Compatibility	8
Safety Precautions	8
Electrical Safety	11
Battery Safety	12
Symbols Used in the Product	14
<b>Specifications</b>	16
Specifications for 400 V Systems	16
Specifications for 208 V Systems	20
Recommended Bolts and Cable Lugs	24
Torque Specifications	24
Requirements for a Third Party Battery Solution	24
Third Party Battery Breaker Requirements	24
Guidance for Organizing Battery Cables	25
UPS Weights and Dimensions	26
UPS Shipping Weights and Dimensions	26
Clearance	26
Environmental	27
Compliance	27
<b>Overview</b>	28
Overview of Single UPS	28
Overview of 1+1 Redundant Parallel System with Common Battery Bank	29
Location of Breakers and Switches	30
<b>Installation Procedure</b>	31
<b>Receiving</b>	32
Remove the UPS from the Pallet	32
<b>Connect the Power Cables</b>	35
<b>Communication Interfaces</b>	37
Route Signal Cables in a 120-160 kVA 400 V/60-80 kVA 208 V UPS	38
Route Signal Cables in a 200 kVA 400 V/100 kVA 208 V UPS	39
Input Contacts and Output Relays	39
Connect the Parallel Cables in a Parallel System	42
Connect Synchronization Cables Between Two UPS Systems (Option)	43
<b>Backfeed Protection</b>	44

# Important Safety Instructions — SAVE THESE INSTRUCTIONS

Read these instructions carefully and look at the equipment to become familiar with it before trying to install, operate, service or maintain it. The following safety messages may appear throughout this manual or on the equipment to warn of potential hazards or to call attention to information that clarifies or simplifies a procedure.



The addition of this symbol to a “Danger” or “Warning” safety message indicates that an electrical hazard exists which will result in personal injury if the instructions are not followed.



This is the safety alert symbol. It is used to alert you to potential personal injury hazards. Obey all safety messages with this symbol to avoid possible injury or death.

## DANGER

**DANGER** indicates a hazardous situation which, if not avoided, **will result in death or serious injury.**

**Failure to follow these instructions will result in death or serious injury.**

## WARNING

**WARNING** indicates a hazardous situation which, if not avoided, **could result in death or serious injury.**

**Failure to follow these instructions can result in death, serious injury, or equipment damage.**

## CAUTION

**CAUTION** indicates a hazardous situation which, if not avoided, **could result in minor or moderate injury.**

**Failure to follow these instructions can result in injury or equipment damage.**

## NOTICE

**NOTICE** is used to address practices not related to physical injury. The safety alert symbol shall not be used with this type of safety message.

**Failure to follow these instructions can result in equipment damage.**

## Please Note

Electrical equipment should only be installed, operated, serviced, and maintained by qualified personnel. No responsibility is assumed by Schneider Electric for any consequences arising out of the use of this material.

A qualified person is one who has skills and knowledge related to the construction, installation, and operation of electrical equipment and has received safety training to recognize and avoid the hazards involved.

Per IEC 62040-1: "Uninterruptible power systems (UPS) -- Part 1: Safety Requirements," this equipment, including battery access, must be inspected, installed and maintained by a skilled person.

The skilled person is a person with relevant education and experience to enable him or her to perceive risks and to avoid hazards which the equipment can create (reference IEC 62040-1, section 3.102).

## Electromagnetic Compatibility

### **NOTICE**

#### **RISK OF ELECTROMAGNETIC DISTURBANCE**

This is a product Category C3 according to IEC 62040-2. This is a product for commercial and industrial applications in the second environment - installation restrictions or additional measures may be needed to prevent disturbances. The second environment includes all commercial, light industry, and industrial locations other than residential, commercial, and light industrial premises directly connected without intermediate transformer to a public low-voltage mains supply. The installation and cabling must follow the electromagnetic compatibility rules, e.g.:

- the segregation of cables,
- the use of shielded or special cables when relevant,
- the use of grounded metallic cable tray and supports.

**Failure to follow these instructions can result in equipment damage.**

## Safety Precautions

### **⚠ DANGER**

#### **HAZARD OF ELECTRIC SHOCK, EXPLOSION, OR ARC FLASH**

All safety instructions in this document must be read, understood and followed.

**Failure to follow these instructions will result in death or serious injury.**

### **⚠ DANGER**

#### **HAZARD OF ELECTRIC SHOCK, EXPLOSION, OR ARC FLASH**

Read all instructions in the Installation Manual before installing or working on this UPS system.

**Failure to follow these instructions will result in death or serious injury.**

### **⚠ DANGER**

#### **HAZARD OF ELECTRIC SHOCK, EXPLOSION, OR ARC FLASH**

Do not install the UPS system until all construction work has been completed and the installation room has been cleaned.

**Failure to follow these instructions will result in death or serious injury.**

## **⚠ DANGER**

### **HAZARD OF ELECTRIC SHOCK, EXPLOSION, OR ARC FLASH**

- The product must be installed according to the specifications and requirements as defined by Schneider Electric. It concerns in particular the external and internal protections (upstream breakers, battery breakers, cabling, etc.) and environmental requirements. No responsibility is assumed by Schneider Electric if these requirements are not respected.
- After the UPS system has been electrically wired, do not start up the system. Start-up must only be performed by Schneider Electric.

**Failure to follow these instructions will result in death or serious injury.**

## **⚠ DANGER**

### **HAZARD OF ELECTRIC SHOCK, EXPLOSION, OR ARC FLASH**

The UPS system must be installed according to local and national regulations. Install the UPS according to:

- IEC 60364 (including 60364-4-41 - protection against electric shock, 60364-4-42 - protection against thermal effect, and 60364-4-43 - protection against overcurrent), **or**
- NEC NFPA 70, **or**
- Canadian Electrical Code (C22.1, Part 1)

depending on which one of the standards apply in your local area.

**Failure to follow these instructions will result in death or serious injury.**

## **⚠ DANGER**

### **HAZARD OF ELECTRIC SHOCK, EXPLOSION, OR ARC FLASH**

- Install the UPS system in a temperature controlled indoor environment free of conductive contaminants and humidity.
- Install the UPS system on a non-flammable, level and solid surface (e.g. concrete) that can support the weight of the system.

**Failure to follow these instructions will result in death or serious injury.**

## **⚠ DANGER**

### **HAZARD OF ELECTRIC SHOCK, EXPLOSION, OR ARC FLASH**

The UPS is not designed for and must therefore not be installed in the following unusual operating environments:

- Damaging fumes
- Explosive mixtures of dust or gases, corrosive gases, or conductive or radiant heat from other sources
- Moisture, abrasive dust, steam or in an excessively damp environment
- Fungus, insects, vermin
- Salt-laden air or contaminated cooling refrigerant
- Pollution degree higher than 2 according to IEC 60664-1
- Exposure to abnormal vibrations, shocks, and tilting
- Exposure to direct sunlight, heat sources, or strong electromagnetic fields

**Failure to follow these instructions will result in death or serious injury.**

**⚠ DANGER**

**HAZARD OF ELECTRIC SHOCK, EXPLOSION, OR ARC FLASH**

Do not drill or cut holes for cables or conduits with the gland plates installed and do not drill or cut holes in close proximity to the UPS.

**Failure to follow these instructions will result in death or serious injury.**

**⚠ WARNING**

**HAZARD OF ARC FLASH**

Do not make mechanical changes to the product (including removal of cabinet parts or drilling/cutting of holes) that are not described in the Installation Manual.

**Failure to follow these instructions can result in death, serious injury, or equipment damage.**

***NOTICE***

**RISK OF OVERHEATING**

Respect the space requirements around the UPS system and do not cover the product's ventilation openings when the UPS system is in operation.

**Failure to follow these instructions can result in equipment damage.**

***NOTICE***

**RISK OF EQUIPMENT DAMAGE**

The UPS must use an external regenerative braking kit to dissipate energy when connected to regenerative loads including photovoltaic systems and speed drives.

**Failure to follow these instructions can result in equipment damage.**

## Electrical Safety

### **⚠ DANGER**

#### **HAZARD OF ELECTRIC SHOCK, EXPLOSION, OR ARC FLASH**

- Electrical equipment must be installed, operated, serviced, and maintained only by qualified personnel.
- Apply appropriate personal protective equipment (PPE) and follow safe electrical work practices.
- Turn off all power supplying the UPS system before working on or inside the equipment.
- Before working on the UPS system, check for hazardous voltage between all terminals including the protective earth.
- The UPS contains an internal energy source. Hazardous voltage can be present even when disconnected from the mains supply. Before installing or servicing the UPS system, ensure that the units are OFF and that mains and batteries are disconnected. Wait five minutes before opening the UPS to allow the capacitors to discharge.
- A disconnection device (e.g. disconnection circuit breaker or switch) must be installed to enable isolation of the system from upstream power sources in accordance with local regulations. The disconnection device must be easily accessible and visible.
- The UPS must be properly earthed/grounded and due to a high leakage current, the earthing/grounding conductor must be connected first.

**Failure to follow these instructions will result in death or serious injury.**

### **⚠ DANGER**

#### **HAZARD OF ELECTRIC SHOCK, EXPLOSION, OR ARC FLASH**

In systems where backfeed protection is not part of the standard design, an automatic isolation device (backfeed protection option or other device meeting the requirements of IEC/EN 62040-1 or UL1778 5th Edition – depending on which of the two standards apply to your local area) must be installed to prevent hazardous voltage or energy at the input terminals of the isolation device. The device must open within 15 seconds after the upstream power supply fails and must be rated according to the specifications.

**Failure to follow these instructions will result in death or serious injury.**

When the UPS input is connected through external isolators that, when opened, isolate the neutral or when the automatic backfeed isolation is provided external to the equipment or is connected to an IT power distribution system, a label must be fitted at the UPS input terminals, and on all primary power isolators installed remote from the UPS area and on external access points between such isolators and the UPS, by the user, displaying the following text (or equivalent in a language which is acceptable in the country in which the UPS system is installed):

### **⚠ DANGER**

#### **HAZARD OF ELECTRIC SHOCK, EXPLOSION, OR ARC FLASH**

Risk of Voltage Backfeed. Before working on this circuit: Isolate the UPS and check for hazardous voltage between all terminals including the protective earth.

**Failure to follow these instructions will result in death or serious injury.**

## CAUTION

### RISK OF ELECTRICAL DISTURBANCE

This product can cause a DC current in the PE conductor. Where a residual current-operated protective device (RCD) is used for protection against electrical shock, only an RCD of Type B is allowed on the supply side of this product.

**Failure to follow these instructions can result in injury or equipment damage.**

## Battery Safety

## DANGER

### HAZARD OF ELECTRIC SHOCK, EXPLOSION, OR ARC FLASH

- Battery circuit breakers must be installed according to the specifications and requirements as defined by Schneider Electric.
- Servicing of batteries must only be performed or supervised by qualified personnel knowledgeable of batteries and the required precautions. Keep unqualified personnel away from batteries.
- Disconnect charging source prior to connecting or disconnecting battery terminals.
- Do not dispose of batteries in a fire as they can explode.
- Do not open, alter, or mutilate batteries. Released electrolyte is harmful to the skin and eyes. It may be toxic.

**Failure to follow these instructions will result in death or serious injury.**

## DANGER

### HAZARD OF ELECTRIC SHOCK, EXPLOSION, OR ARC FLASH

Batteries can present a risk of electric shock and high short-circuit current. The following precautions must be observed when working on batteries

- Remove watches, rings, or other metal objects.
- Use tools with insulated handles.
- Wear protective glasses, gloves and boots.
- Do not lay tools or metal parts on top of batteries.
- Disconnect the charging source prior to connecting or disconnecting battery terminals.
- Determine if the battery is inadvertently grounded. If inadvertently grounded, remove source from ground. Contact with any part of a grounded battery can result in electric shock. The likelihood of such shock can be reduced if such grounds are removed during installation and maintenance (applicable to equipment and remote battery supplies not having a grounded supply circuit).

**Failure to follow these instructions will result in death or serious injury.**

## DANGER

### HAZARD OF ELECTRIC SHOCK, EXPLOSION, OR ARC FLASH

When replacing batteries, always replace with the same type and number of batteries or battery packs.

**Failure to follow these instructions will result in death or serious injury.**

















## **⚠ CAUTION**

### **RISK OF EQUIPMENT DAMAGE**

- Mount the batteries in the UPS system, but do not connect the batteries until the UPS system is ready to be powered up. The time duration from battery connection until the UPS system is powered up must not exceed 72 hours or 3 days.
- Batteries must not be stored more than six months due to the requirement of recharging. If the UPS system remains de-energized for a long period, we recommend that you energize the UPS system for a period of 24 hours at least once every month. This charges the batteries, thus avoiding irreversible damage.

**Failure to follow these instructions can result in injury or equipment damage.**

## Symbols Used in the Product

	This is the earthing/ground symbol.
	This is the protective earth/equipment grounding conductor symbol.
	This is the direct current symbol. It is also referred to as DC.
	This is the alternating current symbol. It is also referred to as AC.
	This is the positive polarity symbol. It is used to identify the positive terminal(s) of equipment which is used with, or generates direct current.
	This is the negative polarity symbol. It is used to identify the negative terminal(s) of equipment which is used with, or generates direct current.
	This is the battery symbol.
	This is the static bypass switch symbol. It is used to indicate switches that are designed to bypass the UPS normal operation, in cases of high inrush or fault conditions.
	This is the AC/DC converter (rectifier) symbol. It is used to identify an AC/DC converter (rectifier) and, in case of plug-in devices, to identify the relevant receptacles.
	This is the DC/AC converter (inverter) symbol. It is used to identify an DC/AC converter (inverter) and, in case of plug-in devices, to identify the relevant receptacles.
	This is the fuse symbol. It is used to identify fuse boxes or their locations.
	This is the input symbol. It is used to identify an input terminal when it is necessary to distinguish between inputs and outputs.
	This is the output symbol. It is used to identify an output terminal when it is necessary to distinguish between inputs and outputs.
	This is the switch disconnecter symbol. It is used to identify the disconnecting device in the form of switch that protects the equipment from short circuit or heavy load current. It opens the circuits once the current flow crosses its maximum limit.
	This is the circuit breaker symbol. It is used to identify the disconnecting device in the form of circuit breaker that protects the equipment from short circuit or heavy load current. It opens the circuits once the current flow crosses its maximum limit.
	This is the circuit breaker/switch symbol. It is used to identify the disconnecting device in the form of circuit breaker or switch that protects the equipment from short circuit or heavy load current. It opens the circuits once the current flow crosses its maximum limit.

<b>N</b>	This is the neutral symbol. It is used to identify the neutral conductors or their locations.
<b>L</b>	This is the phase conductor symbol. It is used to identify the phase conductors or their locations.

# Specifications

## Specifications for 400 V Systems

### Input Specifications

	120 kVA			160 kVA			200 kVA		
<b>Voltage (V)</b>	<b>380</b>	<b>400</b>	<b>415</b>	<b>380</b>	<b>400</b>	<b>415</b>	<b>380</b>	<b>400</b>	<b>415</b>
Connections <sup>1</sup>	L1, L2, L3, N, PE								
Input voltage range (V)	342-477 at full load <sup>2</sup>								
Frequency range (Hz)	40-70								
Nominal input current (A)	192	182	176	256	243	234	320	304	293
Maximum input current (A)	218	207	200	262	262	262	336	336	336
Input current limitation (A)	309			412			515		
Total harmonic distortion (THDI)	<3% for linear loads								
Input power factor	> 0.99								
Maximum short circuit rating	Icc=10 kA								
Protection	Fuse								
Ramp-in	7 seconds								

### Bypass Specifications

	120 kVA			160 kVA			200 kVA		
<b>Voltage (V)</b>	<b>380</b>	<b>400</b>	<b>415</b>	<b>380</b>	<b>400</b>	<b>415</b>	<b>380</b>	<b>400</b>	<b>415</b>
Connections	L1, L2, L3, N, PE								
Overload capacity	110% for 60 minutes 130% for 10 minutes 130-150% for 1 minute								
Minimum bypass voltage (V)	266	280	291	266	280	291	266	280	291
Maximum bypass voltage (V)	475	480	477	475	480	477	475	480	477
Frequency (Hz)	50 or 60								
Frequency range (%)	±1, ±2, ±4, ±5, ±10. Default is ±10 (user selectable).								
Nominal bypass current (A)	184	175	169	246	233	225	307	292	281
Maximum short circuit rating	Icw=10 kA								

1. It is mandatory to have the neutral line for the input and the load. If the input or the load does not have a neutral line, a Δ-Y transformer for input or a Y-Δ transformer for load needs to be installed. And the capacity of the transformer should be >1.2 times the rated capacity of the UPS.
2. 150-342 V with a linear derating of the load to 30%.

## Output Specifications

	120 kVA			160 kVA			200 kVA		
<b>Voltage (V)</b>	<b>380</b>	<b>400</b>	<b>415</b>	<b>380</b>	<b>400</b>	<b>415</b>	<b>380</b>	<b>400</b>	<b>415</b>
Connections <sup>3</sup>	L1, L2, L3, N, PE								
Overload capacity <sup>4</sup>	110% for 60 minutes 125% for 10 minutes 150% for 1 minute								
Output voltage regulation	± 1%								
Dynamic load response	20 milliseconds								
Output power factor	1.0								
Nominal output current (A)	182	173	167	243	231	223	304	289	278
Total harmonic distortion (THDU)	<2% at 100% balanced linear load <5% at 100% non-linear load								
Output frequency (Hz)	50 or 60								
Slew rate (Hz/sec)	Programmable: 0.5 to 2.0. Default is 0.5								
Output performance classification (according to IEC/ EN62040-3)	VFI-SS-111								
Load power factor	0.5 leading to 0.5 lagging without derating								
Output short circuit current	370 A/200 ms			470 A/200 ms			620 A/200 ms		

## Battery Specifications

	120 kVA	160 kVA	200 kVA
Charging power in % of output power	1-20%	1-22.5%	1-24%
Maximum charging power (W)	24000	36000	48000
Nominal battery voltage (2x16 - 2x25 blocks <sup>5</sup> ) (VDC)	± 192 to ± 300		
Nominal float voltage (2x16 - 2x25 blocks <sup>5</sup> ) (VDC)	± 215.5 to ± 337.5		
End of discharge voltage (2x16 - 2x25 blocks) (VDC)	± 153.6 to ± 240		
Battery current at full load and nominal battery voltage (36-50 blocks) (A)	294-211	392-281	490-351
Battery current at full load and minimum battery voltage (36-50 blocks) (A)	369-265	493-353	616-441
Temperature compensation (per cell) <sup>6</sup>	Programmable from 0-7 mV. Default is 0 mV		
Ripple current	< 5% C10		

3. It is mandatory to have the neutral line for the input and the load. If the input or the load does not have a neutral line, a Δ-Y transformer for input or a Y-Δ transformer for load needs to be installed. And the capacity of the transformer should be >1.2 times the rated capacity of the UPS.
4. At 30 °C.
5. 2x16 - 2x17 blocks are only possible when the load is <90%.
6. If the temperature is above 25 °C. If the temperature is below 25 °C, no compensation is needed.

## Recommended Upstream Protection

**NOTE:** For local directives which require 4-pole circuit breakers: If neutral conductor is expected to carry a high current, due to line-neutral non-linear load, the circuit breaker must be rated according to expected neutral current.

	120 kVA		160 kVA		200 kVA	
	Input	Bypass	Input	Bypass	Input	Bypass
Breaker type	NSX250F 36kA AC 3P3D 250A Mic2.2 C25F32D250	NSX250F 36kA AC 3P3D 250A Mic2.2 C25F32D250	NSX400F 36kA AC 3P3D 400A Mic2.3 C40F32D400	NSX400F 36kA AC 3P3D 400A Mic2.3 C40F32D400	NSX400F 36kA AC 3P3D 400A Mic2.3 C40F32D400	NSX400F 36kA AC 3P3D 400A Mic2.3 C40F32D400
Io setting	250	250	360	320	400	400
Ir setting	0.97	0.95	0.9	0.98	1	0.98
I <sub>sd</sub> setting	1.5-10	1.5-10	1.5-10	1.5-10	1.5-10	1.5-10

## Recommended Cable Sizes

 **DANGER**

**HAZARD OF ELECTRIC SHOCK, EXPLOSION, OR ARC FLASH**

All wiring must comply with all applicable national and/or electrical codes. The maximum allowable cable size is 150 mm<sup>2</sup>.

**Failure to follow these instructions will result in death or serious injury.**

Cable sizes in this manual are based on table B.52.5 of IEC 60364-5-52 with the following assertions:

- 90 °C conductors
- An ambient temperature of 30 °C
- Use of copper conductors
- Installation method C

PE size is based on table 54.2 of IEC 60364-5-54.

If the ambient temperature is greater than 30 °C, larger conductors are to be used in accordance with the correction factors of the IEC.

**NOTE:** The battery cable sizes given here are recommendations – Always follow the specific instructions in the battery solution documentation for battery cable sizes and battery PE cable sizes and ensure that the battery cable sizes match the battery breaker rating.

**NOTE:** Recommended cable sizes and maximum allowable cable size may vary for the auxiliary products. Refer to the installation manual provided with the auxiliary product.

**NOTE:** Neutral conductor is sized to handle 1.73 times phase current in case of high harmonic content from non-linear loads. If non or less harmonic currents are expected, neutral conductor can be sized accordingly but not less than the phase conductor.

### 120 kVA

#### Copper

	Cable size per phase (mm <sup>2</sup> )	Neutral cable size (mm <sup>2</sup> )	PE cable size (mm <sup>2</sup> )
Input	95	120	50
Bypass	95	120	50

**Copper (Continued)**

	Cable size per phase (mm <sup>2</sup> )	Neutral cable size (mm <sup>2</sup> )	PE cable size (mm <sup>2</sup> )
Output	95	120	50
Battery	2x70	2x70	70

**160 kVA****Copper**

	Cable size per phase (mm <sup>2</sup> )	Neutral cable size (mm <sup>2</sup> )	PE cable size (mm <sup>2</sup> )
Input	120	120	70
Bypass	120	120	70
Output	120	120	70
Battery	2x95	2x95	95

**200 kVA****Copper**

	Cable size per phase (mm <sup>2</sup> )	Neutral cable size (mm <sup>2</sup> )	PE cable size (mm <sup>2</sup> )
Input	150	150	95
Bypass	150	150	95
Output	150	150	95
Battery	2x120	2x120	120

**Heat Dissipation**

	120 kVA		160 kVA		200 kVA	
	W	BTU/hr	W	BTU/hr	W	BTU/hr
Normal mode	6000	20473	8000	27297	10000	34121
Battery mode	6000	20473	8000	27297	10000	34121
ECO mode	1020	3480	1600	5459	2000	6824

## Specifications for 208 V Systems

### Input Specifications

Voltage (V)	60 kVA			80 kVA			100 kVA		
	200	208	220	200	208	220	200	208	220
Connections <sup>7</sup>	L1, L2, L3, N, PE								
Input voltage range (V)	180-272 at full load <sup>8</sup>								
Frequency range (Hz)	40-70								
Nominal input current (A)	192	184	172	255	244	229	321	306	287
Maximum input current (A)	203	195	183	260	249	234	325	310	291
Input current limitation (A)	307			408			514		
Total harmonic distortion (THDI)	<3% for linear loads								
Input power factor	> 0.99								
Maximum short circuit rating	I <sub>cc</sub> =10 kA								
Protection	Fuse								
Ramp-in	12 seconds								

### Bypass Specifications

Voltage (V)	60 kVA			80 kVA			100 kVA		
	200	208	220	200	208	220	200	208	220
Connections	L1, L2, L3, N, PE								
Overload capacity	110% for 60 minutes 130% for 10 minutes 130-150% for 1 minute								
Minimum bypass voltage (V)	140	146	154	140	146	154	140	146	154
Maximum bypass voltage (V)	250	260	275	250	260	275	250	260	275
Frequency (Hz)	50 or 60								
Frequency range (%)	±1, ±2, ±4, ±5, ±10. Default is ±10 (user selectable).								
Nominal bypass current (A)	176	169	160	235	226	213	294	282	266
Maximum short circuit rating	I <sub>cw</sub> =10 kA								

7. It is mandatory to have the neutral line for the input and the load. If the input or the load does not have a neutral line, a Δ-Y transformer for input or a Y-Δ transformer for load needs to be installed. And the capacity of the transformer should be >1.2 times the rated capacity of the UPS.
8. 126-180 V with a linear derating of the load to 30%.

## Output Specifications

Voltage (V)	60 kVA			80 kVA			100 kVA		
	200	208	220	200	208	220	200	208	220
Connections <sup>9</sup>	L1, L2, L3, N, PE								
Overload capacity <sup>10</sup>	110% for 60 minutes 125% for 10 minutes 150% for 1 minute								
Output voltage regulation	± 1%								
Dynamic load response	20 milliseconds								
Output power factor	1.0								
Nominal output current (A)	173	167	157	231	222	210	289	278	262
Total harmonic distortion (THDU)	<3% at 100% linear load <5% at 100% non-linear load								
Output frequency (Hz)	50 or 60								
Slew rate (Hz/sec)	Programmable: 0.5 to 2.0. Default is 0.5								
Output performance classification (according to IEC/ EN62040-3)	VFI-SS-111								
Load power factor	0.5 leading to 0.5 lagging without derating								
Output short circuit current	370 A/200 ms			470 A/200 ms			620 A/200 ms		

## Battery Specifications

	60 kVA	80 kVA	100 kVA
Charging power in % of output power	1-32%	1-36%	1-38.4%
Maximum charging power (W)	19200	28800	38400
Nominal battery voltage (2x16 - 2x20 blocks) (VDC)	± 192 to ± 240		
Nominal float voltage (2x16 - 2x20 blocks) (VDC)	± 215.5 to ± 270		
End of discharge voltage (2x16 - 2x20 blocks) (VDC)	± 153.6 to ± 192		
Battery current at full load and nominal battery voltage (2x16 - 2x20 blocks) (A)	168-134	223-179	280-224
Battery current at full load and minimum battery voltage (2x16 - 2x20 blocks) (A)	209-168	279-223	350-280
Temperature compensation (per cell) <sup>11</sup>	Programmable from 0-7 mV. Default is 0 mV		
Ripple current	< 5% C10		

9. It is mandatory to have the neutral line for the input and the load. If the input or the load does not have a neutral line, a Δ-Y transformer for input or a Y-Δ transformer for load needs to be installed. And the capacity of the transformer should be >1.2 times the rated capacity of the UPS.

10. At 30 °C.

11. If the temperature is above 25 °C. If the temperature is below 25 °C, no compensation is needed.

## Recommended Upstream Protection

**NOTE:** For local directives which require 4-pole circuit breakers: If neutral conductor is expected to carry a high current, due to line-neutral non-linear load, the circuit breaker must be rated according to expected neutral current.

	60 kVA		80 kVA		100 kVA	
	Input	Bypass	Input	Bypass	Input	Bypass
Breaker type	NSX250F 36kA AC 3P3D 250A Mic2.2 C25F32D250	NSX250F 36kA AC 3P3D 250A Mic2.2 C25F32D250	NSX400F 36kA AC 3P3D 400A Mic2.3 C40F32D400	NSX400F 36kA AC 3P3D 400A Mic2.3 C40F32D400	NSX400F 36kA AC 3P3D 400A Mic2.3 C40F32D400	NSX400F 36kA AC 3P3D 400A Mic2.3 C40F32D400
Io setting	250	250	360	320	400	400
Ir setting	0.97	0.95	0.9	0.98	1	0.98
I <sub>sd</sub> setting	1.5-10	1.5-10	1.5-10	1.5-10	1.5-10	1.5-10

## Recommended Cable Sizes

**DANGER**

**HAZARD OF ELECTRIC SHOCK, EXPLOSION, OR ARC FLASH**

All wiring must comply with all applicable national and/or electrical codes. The maximum allowable cable size is 150 mm<sup>2</sup>.

**Failure to follow these instructions will result in death or serious injury.**

Cable sizes in this manual are based on table B.52.5 of IEC 60364-5-52 with the following assertions:

- 90 °C conductors
- An ambient temperature of 30 °C
- Use of copper conductors
- Installation method C

PE size is based on table 54.2 of IEC 60364-5-54.

If the ambient temperature is greater than 30 °C, larger conductors are to be used in accordance with the correction factors of the IEC.

**NOTE:** The battery cable sizes given here are recommendations – Always follow the specific instructions in the battery solution documentation for battery cable sizes and battery PE cable sizes and ensure that the battery cable sizes match the battery breaker rating.

**NOTE:** Recommended cable sizes and maximum allowable cable size may vary for the auxiliary products. Refer to the installation manual provided with the auxiliary product.

**NOTE:** Neutral conductor is sized to handle 1.73 times phase current in case of high harmonic content from non-linear loads. If non or less harmonic currents are expected, neutral conductor can be sized accordingly but not less than the phase conductor.

### 60 kVA

#### Copper

	Cable size per phase (mm <sup>2</sup> )	Neutral cable size (mm <sup>2</sup> )	PE cable size (mm <sup>2</sup> )
Input	95	120	50
Bypass	95	120	50

**Copper (Continued)**

	Cable size per phase (mm <sup>2</sup> )	Neutral cable size (mm <sup>2</sup> )	PE cable size (mm <sup>2</sup> )
Output	95	120	50
Battery	70	70	70

**80 kVA****Copper**

	Cable size per phase (mm <sup>2</sup> )	Neutral cable size (mm <sup>2</sup> )	PE cable size (mm <sup>2</sup> )
Input	120	120	70
Bypass	120	120	70
Output	120	120	70
Battery	2x70	2x70	70

**100 kVA****Copper**

	Cable size per phase (mm <sup>2</sup> )	Neutral cable size (mm <sup>2</sup> )	PE cable size (mm <sup>2</sup> )
Input	150	150	95
Bypass	150	150	95
Output	150	150	95
Battery	2x70	2x70	70

**Heat Dissipation**

	60 kVA		80 kVA		100 kVA	
	W	BTU/hr	W	BTU/hr	W	BTU/hr
Normal mode	5418	18486	7910	26989	10198	34796
Battery mode	4241	14470	5732	19558	7353	25087
ECO mode	1200	4094	1552	5295	1970	6722

## Recommended Bolts and Cable Lugs

Cable size (mm <sup>2</sup> )	Bolt size	Cable lug type
50	M8	KST TLK50-8
70	M10	KST TLK70-10
95	M10	KST TLK95-10
120	M10	KST TLK120-10
150	M10	KST TLK150-10

**NOTE:** If the recommended lug type is not available, use a local M8/M10 lug type as a substitute.

## Torque Specifications

Bolt Size	Torque
M8	17.5 Nm
M10	30 Nm

## Requirements for a Third Party Battery Solution

Battery breaker boxes from Schneider Electric are recommended for the battery interface. Please contact Schneider Electric for more information.

## Third Party Battery Breaker Requirements

 **DANGER**

**HAZARD OF ELECTRIC SHOCK, EXPLOSION, OR ARC FLASH**

All selected battery breakers must be equipped with instantaneous trip functionality with an undervoltage release coil or a shunt trip release coil.

**Failure to follow these instructions will result in death or serious injury.**

**NOTE:** There are more factors to consider when selecting a battery breaker than the requirements listed below. Please contact Schneider Electric for more information.

### Design Requirements for Battery Breaker

Battery breaker rated DC voltage > Normal battery voltage	The normal voltage of the battery configuration is defined as the highest nominal occurring battery voltage. This can be equivalent to the float voltage which may be defined as <b>number of battery blocks x number of cells x cell float voltage</b> .
Battery breaker rated DC current > Rated discharge battery current	This current is controlled by the UPS and must include maximum discharge current. This will typically be the current at the end of discharge (minimum operation DC voltage or in overload condition or a combination).
DC landings	Three DC landings (+, -, N) for DC cables are required.

**Design Requirements for Battery Breaker (Continued)**

AUX switches for monitoring	One AUX switch must be installed in each battery breaker and connected to the UPS. The UPS can monitor one battery breaker.
Short-circuit breaking capability	The short-circuit breaking capability must be higher than the short-circuit DC current of the (largest) battery configuration.
Minimum trip current	The minimum short-circuit current to trip the battery breaker must match the (smallest) battery configuration, to make the breaker trip in case of a short circuit, up to the end of its life time.

**Guidance for Organizing Battery Cables**

**NOTE:** For 3rd party batteries, use only high rate batteries for UPS applications.

**NOTE:** When the battery bank is placed remotely, the organizing of the cables is important to reduce voltage drop and inductance. The distance between the battery bank and the UPS must not exceed 200 m (656 ft). Contact Schneider Electric for installations with a longer distance.

**NOTE:** To minimize the risk of electromagnetic radiation, it is highly recommended to follow the below guidance and to use grounded metallic tray supports.

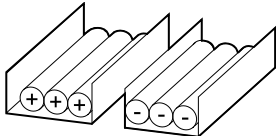
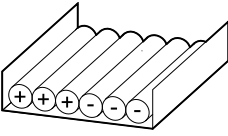
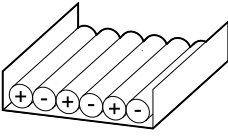
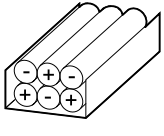
Cable Length				
<30 m	Not recommended	Acceptable	Recommended	Recommended
31–75 m	Not recommended	Not recommended	Acceptable	Recommended
76–150 m	Not recommended	Not recommended	Acceptable	Recommended
151–200 m	Not recommended	Not recommended	Not recommended	Recommended

## UPS Weights and Dimensions

UPS	Weight kg	Height mm	Width mm	Depth mm
120 kVA 400 V/60 kVA 208 V	193	1300	500	850
160 kVA 400 V/80 kVA 208 V	227	1300	500	850
200 kVA 400 V/100 kVA 208 V	304	1300	600	850

## UPS Shipping Weights and Dimensions

UPS	Weight kg	Height mm	Width mm	Depth mm
120 kVA 400 V/60 kVA 208 V	223	1500	625	975
160 kVA 400 V/80 kVA 208 V	257	1500	625	975
200 kVA 400 V/100 kVA 208 V	338	1500	725	975

## Clearance

**NOTE:** Clearance dimensions are published for airflow and service access only. Consult with the local safety codes and standards for additional requirements in your local area.

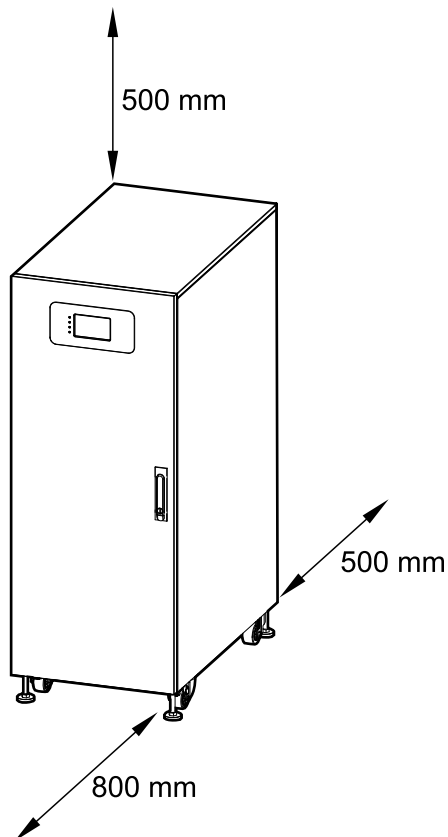

## Environmental

	Operating	Storage
Temperature	0 °C to 40 °C Recommended optimal temperature for batteries: 20 °C to 25 °C	-15 °C to 40 °C for systems with batteries -25 °C to 55 °C for systems without batteries
Relative humidity	0–95% non-condensing	
Elevation According to IEC 62040–3	Power derating factor: 0-1500 m: 1.000 1500-2000 m: 0.975	< 15000 m above sea level (or in an environment with equivalent air pressure)
Audible noise	<70 dBA at full load and an ambient temperature of 30 °C <sup>12</sup>	
Protection class	IP20 (air filter as standard)	
Color	RAL 9003	

## Compliance

Safety	IEC 62040-1:2017, Edition 2.0, Uninterruptible power systems (UPS) – Part 1: Safety requirements IEC 62040-1: 2008-6, 1st edition, Uninterruptible Power Systems (UPS) – Part 1: General and safety requirements for UPS IEC 62040-1:2013-01, 1st edition amendment 1
EMC/EMI/RFI	IEC 62040-2:2016, Edition 3.0, Uninterruptible power systems (UPS) – Part 2: Electromagnetic compatibility (EMC) requirements. IEC 62040-2:2005-10, 2nd edition, Uninterruptible Power Systems (UPS) – Part 2: Electromagnetic compatibility (EMC) requirements
Performance	IEC 62040-3: 2011-03, 2nd edition Uninterruptible Power Systems (UPS) - Part 3: Method of specifying the performance and test requirements
Markings	CE, RCM, EAC, WEEE, UKCA
Transportation	ISTA 2B
Pollution degree	2
Overvoltage category	III
Earthing system	TN, TT, or IT

12. According to ISO 3746.

# Overview

## Overview of Single UPS

UIB	Unit input switch
SSIB	Static switch input switch
UOB	Unit output switch
MBB	Maintenance bypass switch

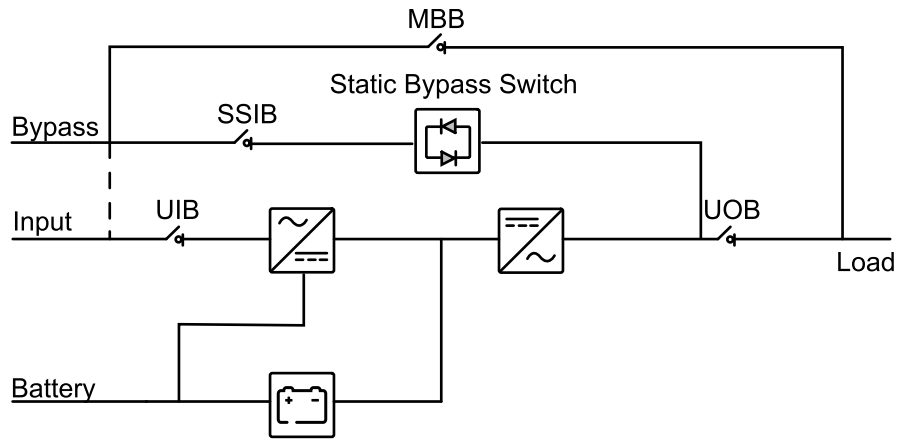

# Overview of 1+1 Redundant Parallel System with Common Battery Bank

MIB	Mains input breaker
BIB	Bypass input breaker
UIB	Unit input switch
SSIB	Static switch input switch
UOB	Unit output switch
Ext. UOB	External unit output breaker
MBB	Maintenance bypass switch
Ext. MBB	External maintenance bypass breaker
BB1	Battery breaker 1
BB2	Battery breaker 2

**NOTE:** Common battery banks are not supported in systems with internal batteries.

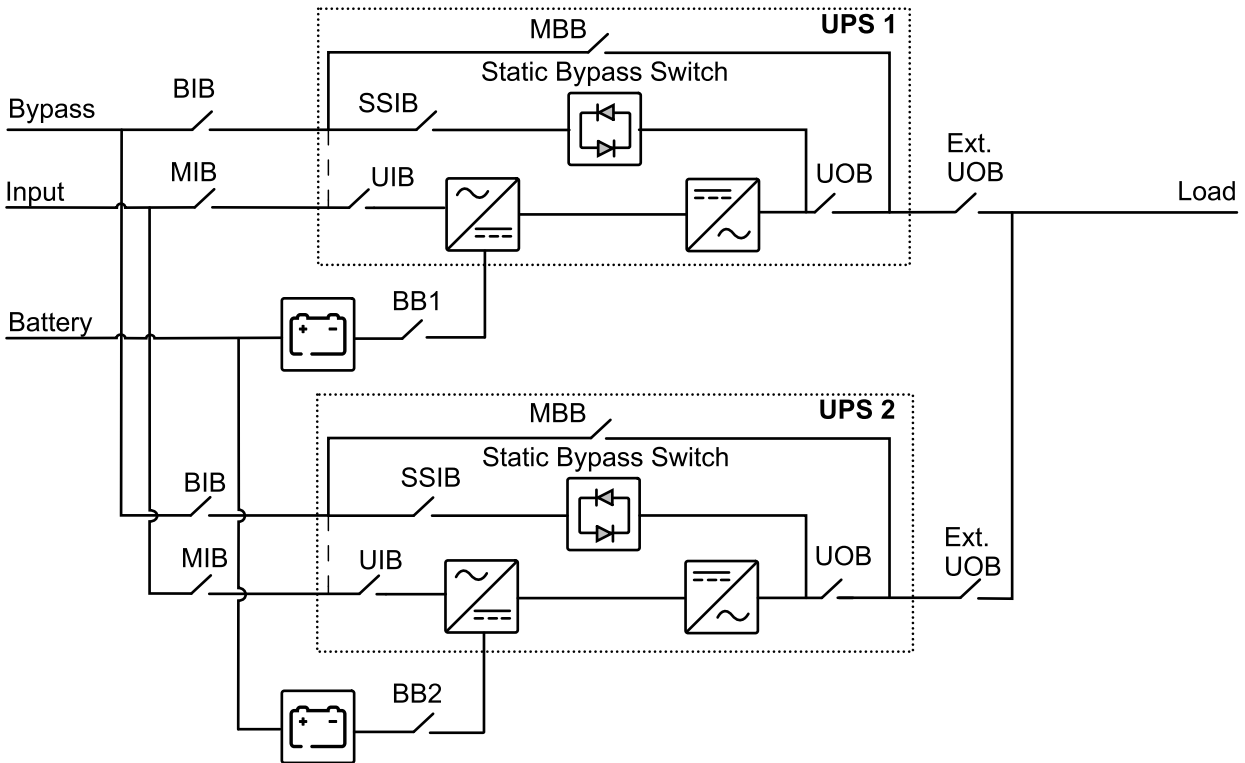

## Location of Breakers and Switches

**120-160 kVA 400 V/60-80 kVA 208 V UPS for External Batteries**

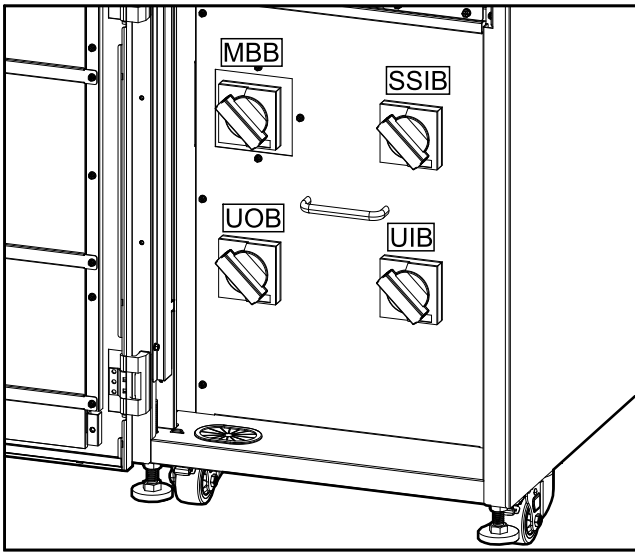

**200 kVA 400 V/100 kVA 208 V UPS for External Batteries**

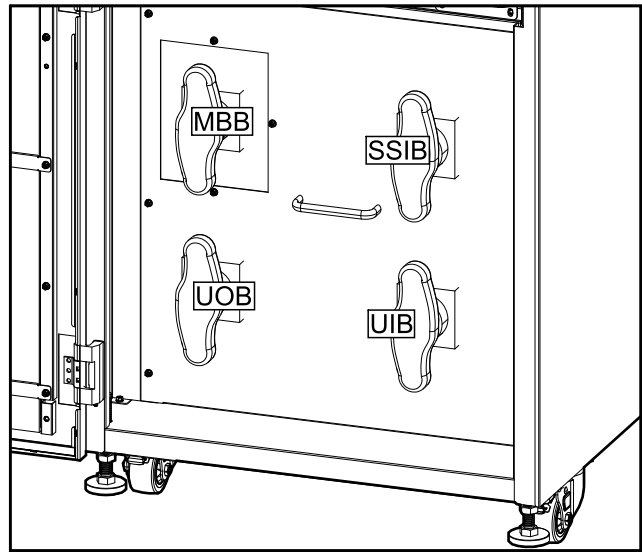

# Installation Procedure

1. Remove the UPS from the Pallet, page 32.
2. Connect the Power Cables, page 35.
3. Perform one of the following:
  - Route Signal Cables in a 120-160 kVA 400 V/60-80 kVA 208 V UPS, page 38, or
  - Route Signal Cables in a 200 kVA 400 V/100 kVA 208 V UPS, page 39.
4. Connect the signal cables. See Communication Interfaces, page 37 and Input Contacts and Output Relays, page 39 for details.
5. **Only for parallel system:** Connect the Parallel Cables in a Parallel System, page 42.
6. **Optional:** Connect Synchronization Cables Between Two UPS Systems (Option), page 43.

# Receiving

## External Inspection

When the shipment arrives, inspect the shipping material for any signs of damage or mishandling. Do not attempt to install the system if a damage is apparent. If any damage is noted, contact Schneider Electric and file a damage claim with the shipping agency within 24 hours.

Compare the components of the shipment with the bill of lading. Report any missing items to the carrier and to Schneider Electric immediately.

Verify that labelled units match the order confirmation.

## Remove the UPS from the Pallet

1. Move the UPS to the final installation area using a forklift.
2. Remove the shipping materials and the ramp from the UPS.

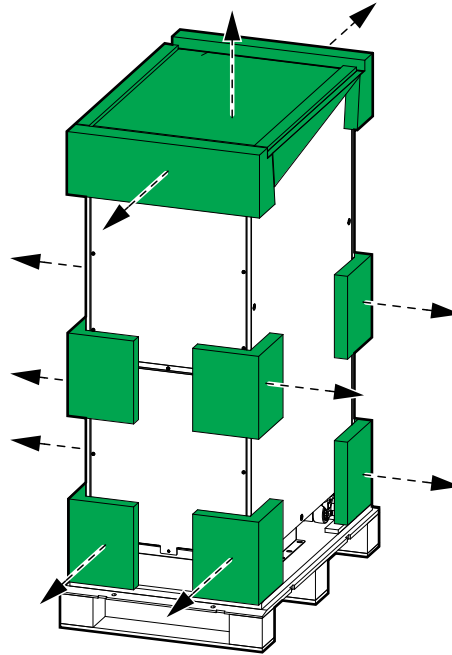
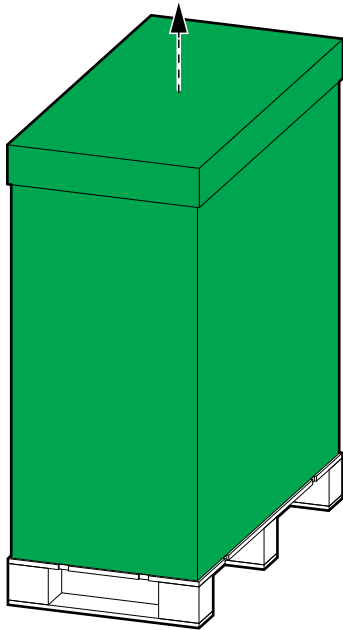

3. Loosen the bolts and remove the shipping brackets. Save the bolts for the ramp and dispose of the shipping brackets.

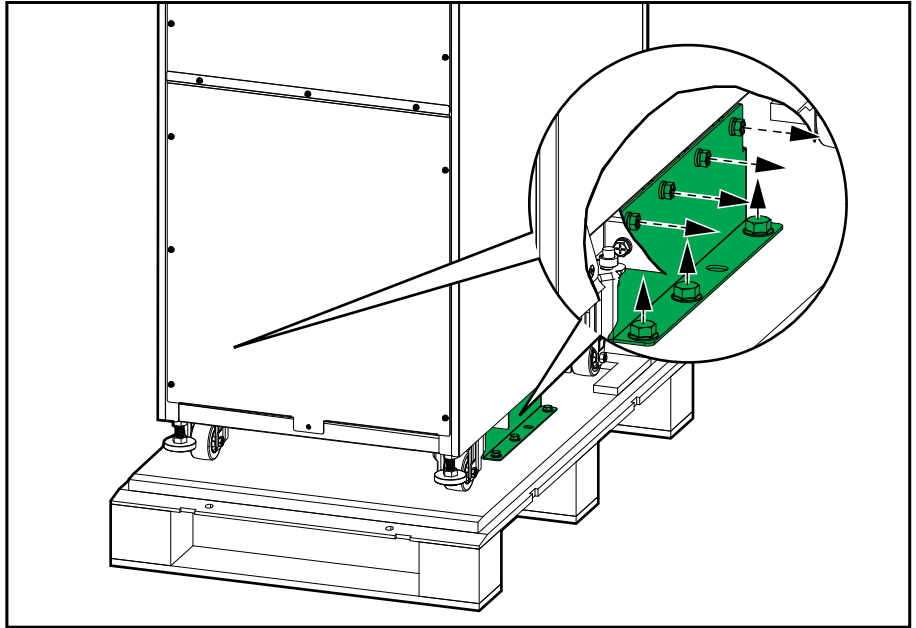

4. Place the ramp on the rear side and fasten to the pallet with the bolts from the shipping bracket.

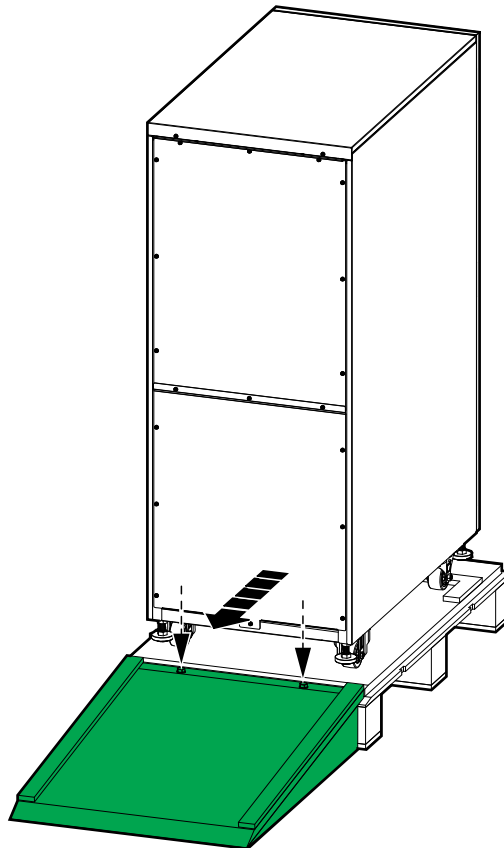

5. Roll the UPS down from the pallet.

6. Move the UPS to its final location and use a wrench to lower the levelling feet. Ensure that the UPS is level.

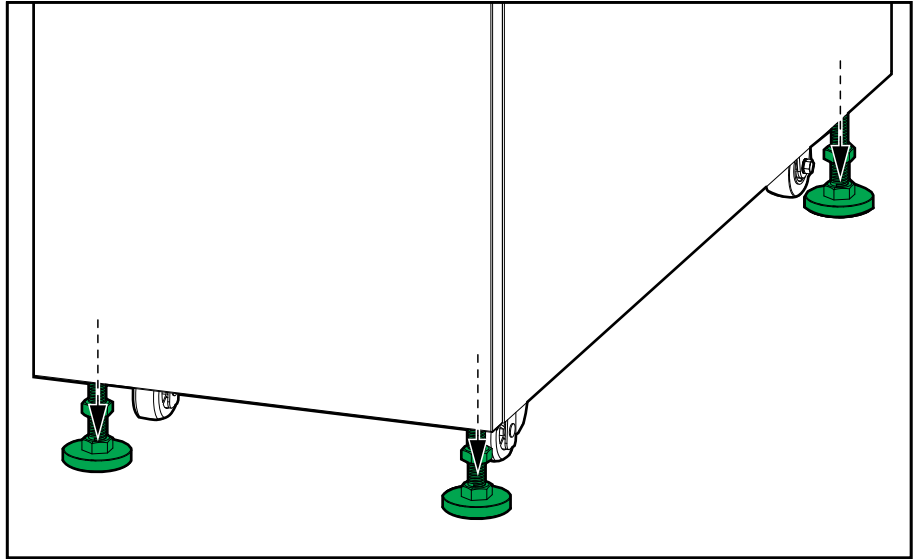

7. Lock the wheels.



## Connect the Power Cables

1. Ensure that all breakers are in the OFF (open) position.
2. Remove the two indicated plates.

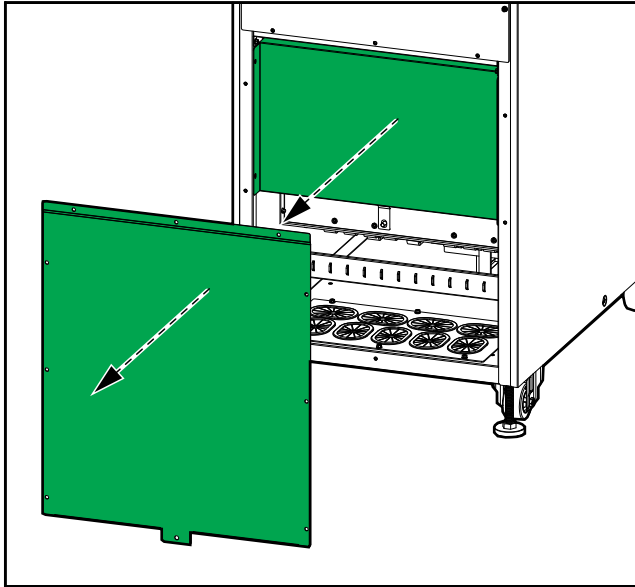
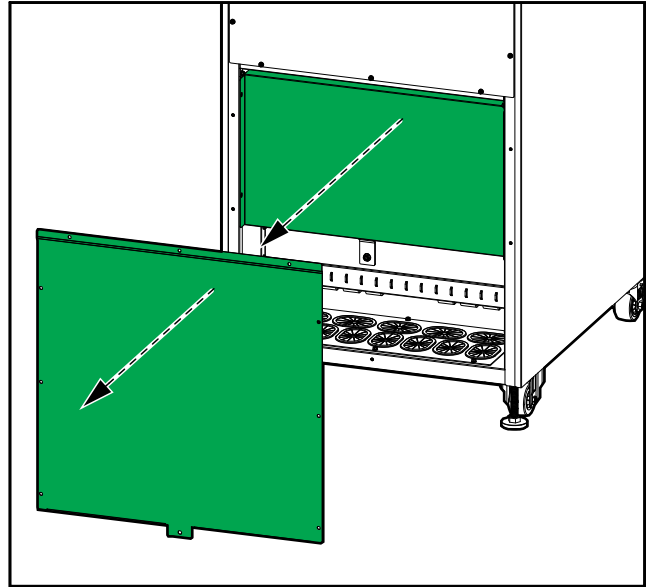
**Rear View 120-160 kVA 400 V/60-80 kVA 208 V UPS****Rear View 200 kVA 400 V/100 kVA 208 V UPS**

3. In dual mains systems, remove the three single mains busbars.

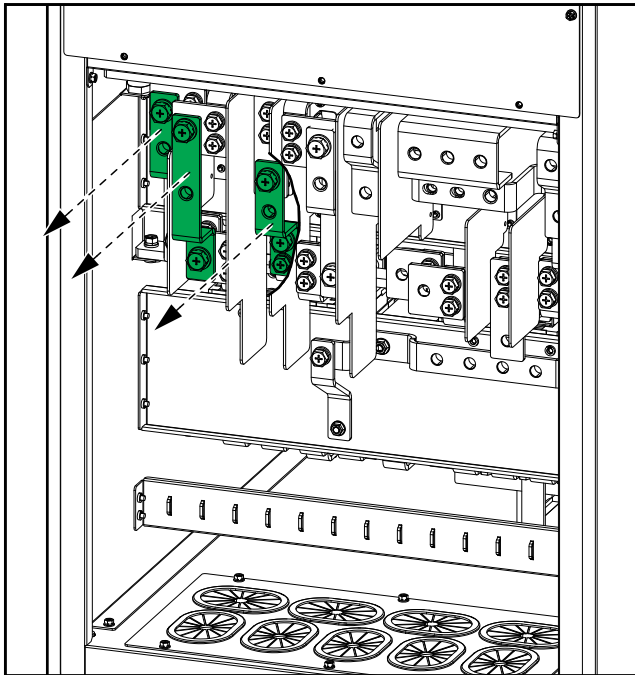
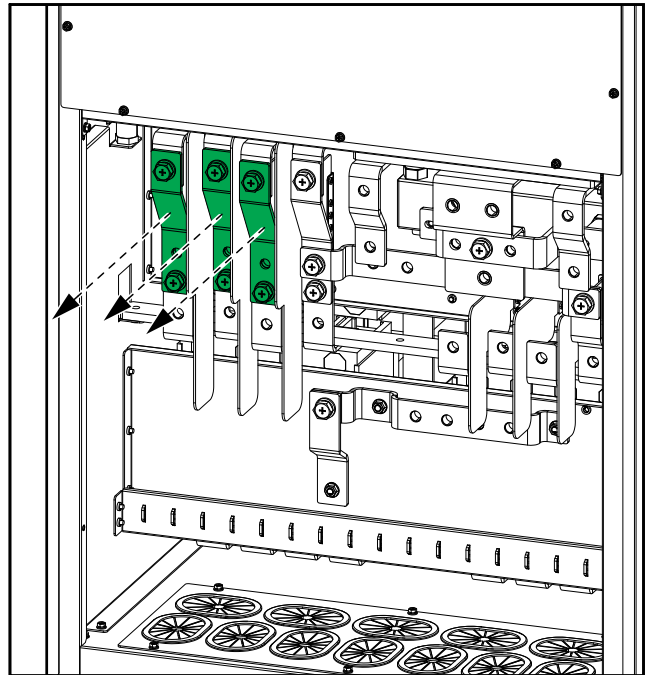
**Rear View 120-160 kVA 400 V/60-80 kVA 208 V UPS****Rear View 200 kVA 400 V/100 kVA 208 V UPS**

- In TN-C systems only, rotate the jumper busbar to create a connection between the PE busbar and the neutral busbar.

Rear View 120-160 kVA 400 V/60-80 kVA 208 V UPS

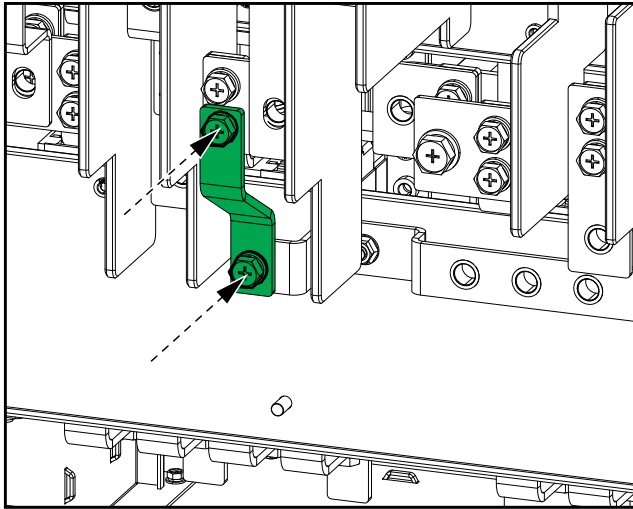

Rear View 200 kVA 400 V/100 kVA 208 V UPS

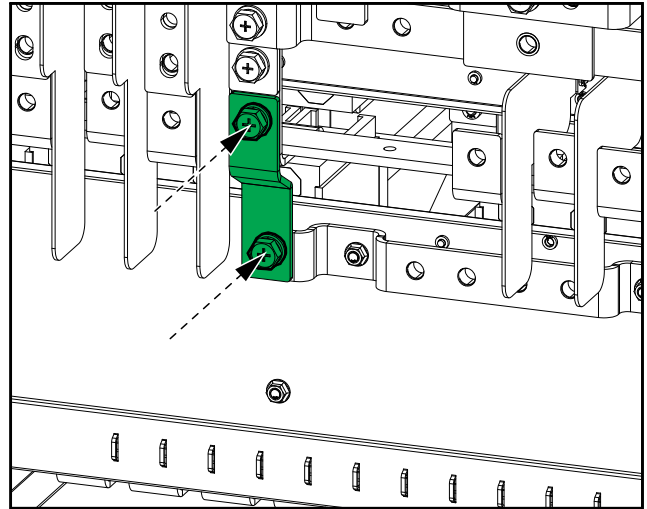

- Route the power cables through the bottom of the UPS.
- Connect the PE cable to the PE terminal.

Rear View 120-160 kVA 400 V/60-80 kVA 208 V UPS

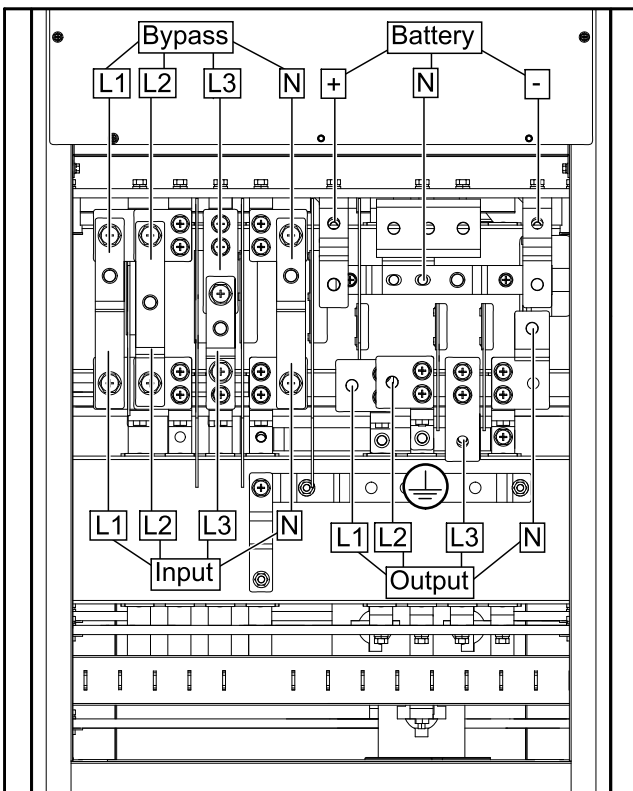

Rear View 200 kVA 400 V/100 kVA 208 V UPS

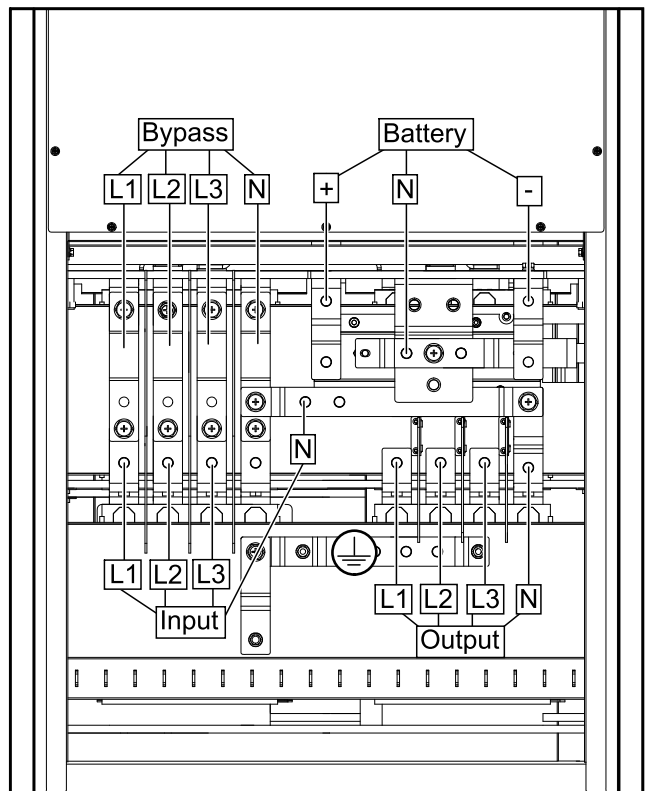

- Connect the input, output, and bypass (if applicable) cables.
- Connect the battery cables.
- Fasten the cables to the cable relief in the bottom of the UPS.
- Reinstall the two plates.

# Communication Interfaces

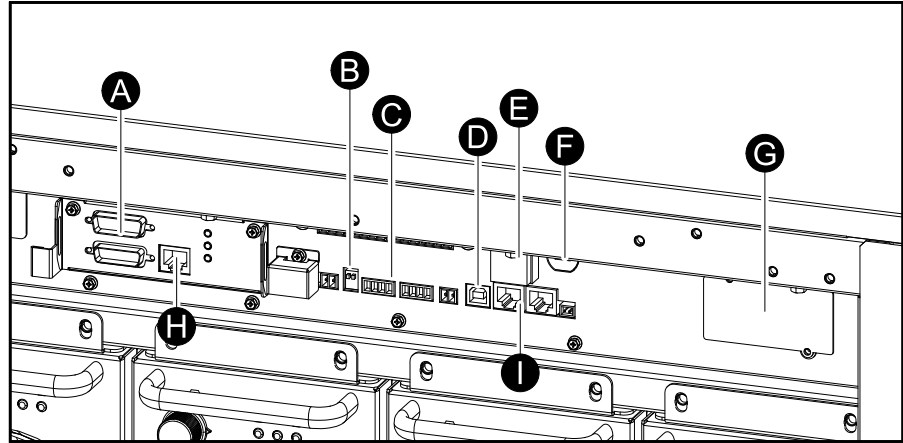

- A. Parallel ports
- B. CAN\_R: CAN termination resistor
- C. Dry contacts
- D. USB port
- E. EPO
- F. Slot for optional cold start button
- G. Network management card (NMC)
- H. Load bus synchronization port
- I. RS485

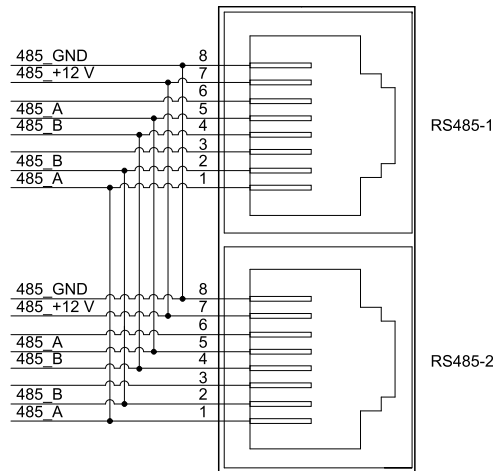

## Route Signal Cables in a 120-160 kVA 400 V/60-80 kVA 208 V UPS

1. Remove the two covers in the left side.

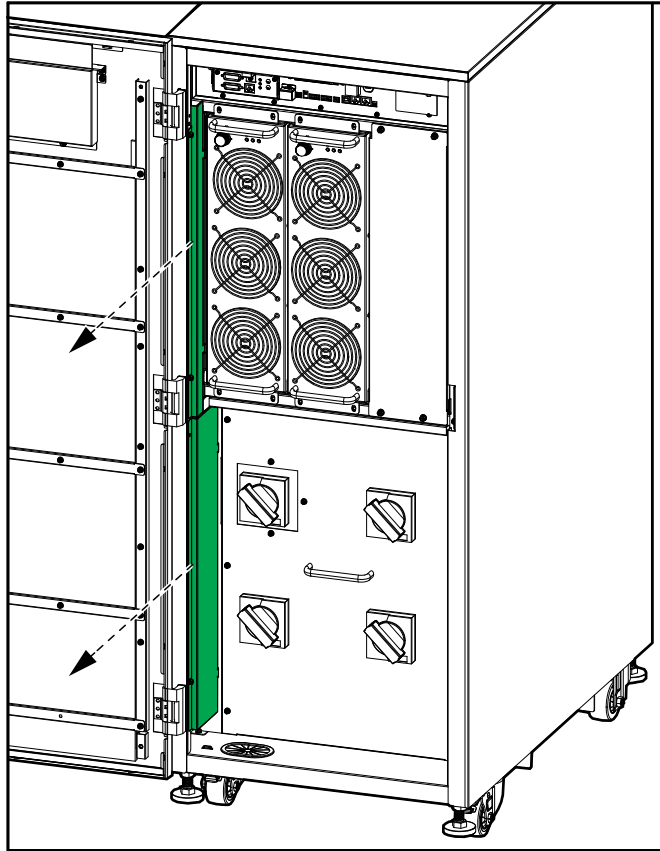

2. Route the signal cables through the bottom and to the communication interface. Fasten the cables to the cable reliefs.

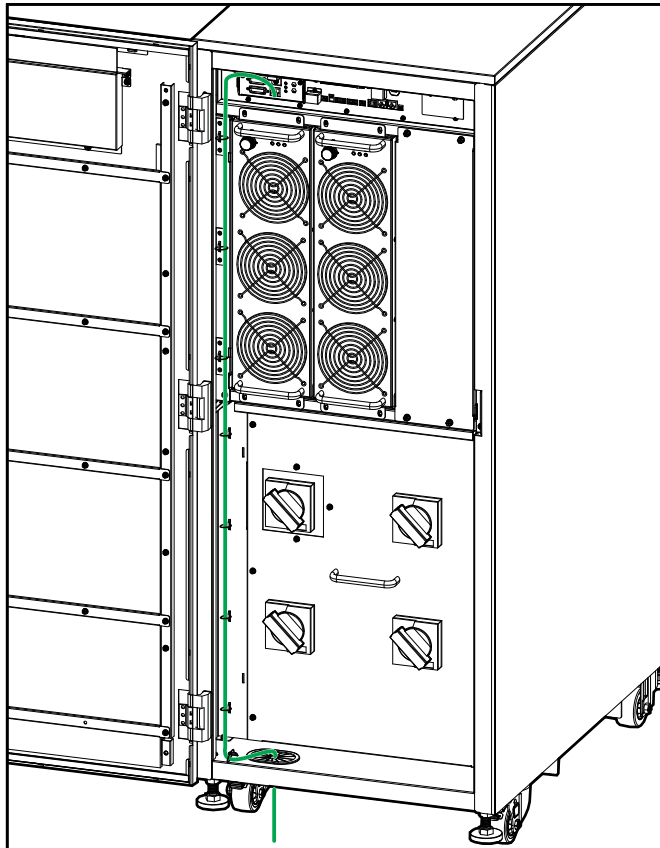

3. Reinstall the covers in the left side.

## Route Signal Cables in a 200 kVA 400 V/100 kVA 208 V UPS

1. Remove the top plate.
2. Remove the plate in front of the gland plate.

### Rear View of the UPS

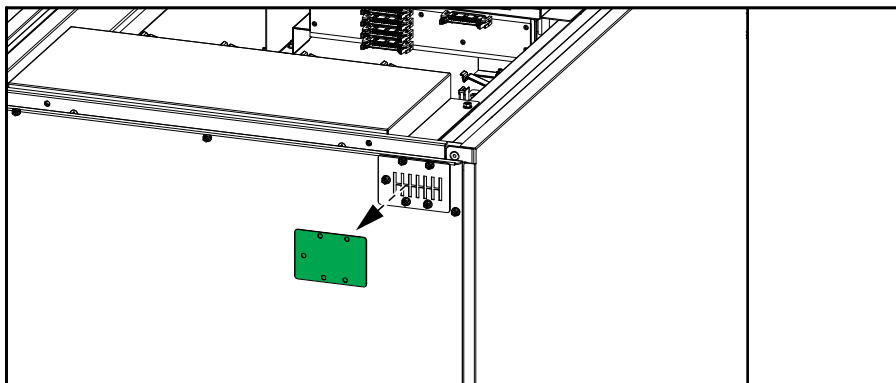

3. Route the signal cables through the rear brush plate through the cable channel and to the communication interface on the front of the UPS.

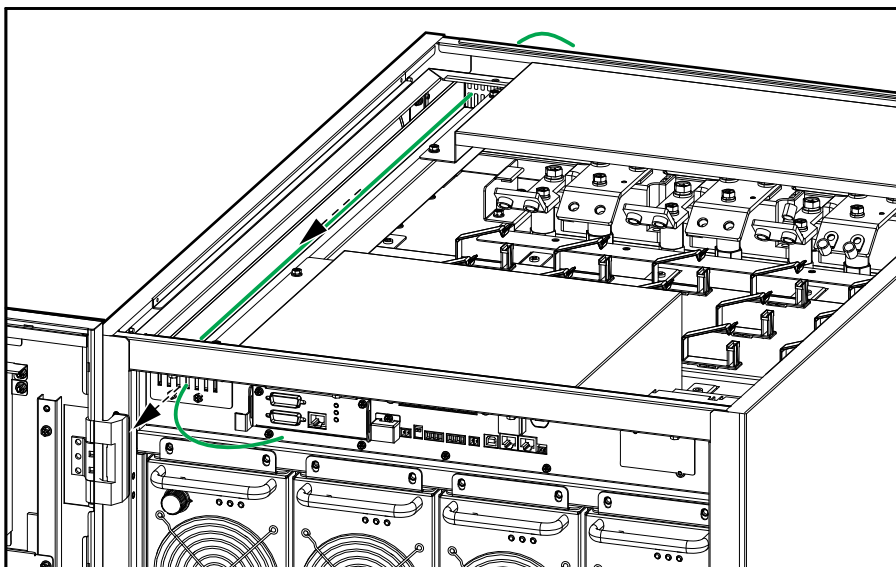

4. Reinstall the top plate.

## Input Contacts and Output Relays

### **NOTICE**

#### **RISK OF EQUIPMENT DAMAGE**

The battery breaker contact drive J6-1 and J6-2 can provide a maximum of +24 VDC 400 mA to the undervoltage release coil or shunt trip release coil. If this value is exceeded it can damage the UPS.

**Failure to follow these instructions can result in equipment damage.**

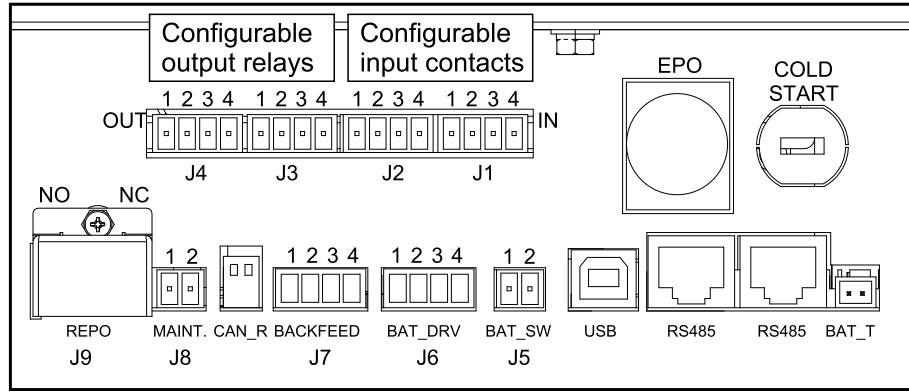

Terminal	Function	
BAT_T-1	Input contact for battery temperature sensor	
BAT_T-2	Signal ground	
J5-1	AUX contact for battery breaker	12 VDC/12 mA Class2/SELV
J5-2	Signal ground	
J6-1	Normally closed output contact for battery breaker trip	24 VDC/400 mA Class2/SELV
J6-2	Normally open output contact for battery breaker trip	
J6-4	Signal ground	
J7-1	Backfeed 1 output relay pin 1 (normally closed (NC) as default)	30 VDC/1 A Class2/SELV
J7-2	Backfeed 1 output relay pin 2 (normally closed (NC) as default)	
J7-3	Backfeed 2 output relay pin 1 (normally closed (NC) as default)	
J7-4	Backfeed 2 output relay pin 2 (normally closed (NC) as default)	
J8-1	AUX contact for external maintenance bypass breaker	12 VDC/12 mA Class2/SELV
J8-2	Signal ground	
J9-1	Normally open EPO contact	<b>NO configuration</b> 12 VDC/12 mA Class2/SELV 12 VDC/12 mA Class2/SELV
J9-2	Signal ground	
J9-3	Normally closed EPO contact	
J9-4	Signal ground	

## Configurable Input Contacts

The four configurable input contacts can be configured from the display with the following functions:

- **Disable**
- **INV ON**
- **INV OFF**
- **Battery alarm**
- **Genset enable**
- **Custom alarm 3**
- **Custom alarm 4**
- **Disable ECO**

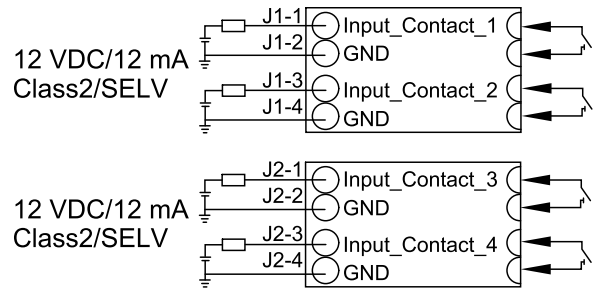

## Configurable Output Relays

The four configurable output contacts can be configured from the display with the following functions:

- **Disable**
- **Common alarm**
- **Normal operation**
- **Battery operation**
- **Static bypass operation**
- **Output overload**
- **Fan inoperable**
- **Battery alarm**
- **Battery disconnected**
- **Battery voltage low**
- **Input out of tolerance**
- **Bypass out of tolerance**
- **EPO activated**
- **Maintenance mode**
- **Parallel lost**

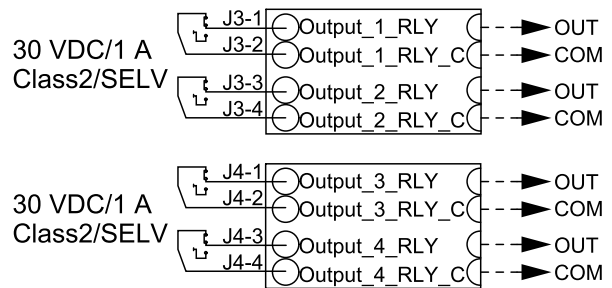

## Connect the Parallel Cables in a Parallel System

1. Connect the optional parallel cables between all the UPSs of the parallel system.

**NOTE:** For location of parallel ports see Communication Interfaces, page 37.

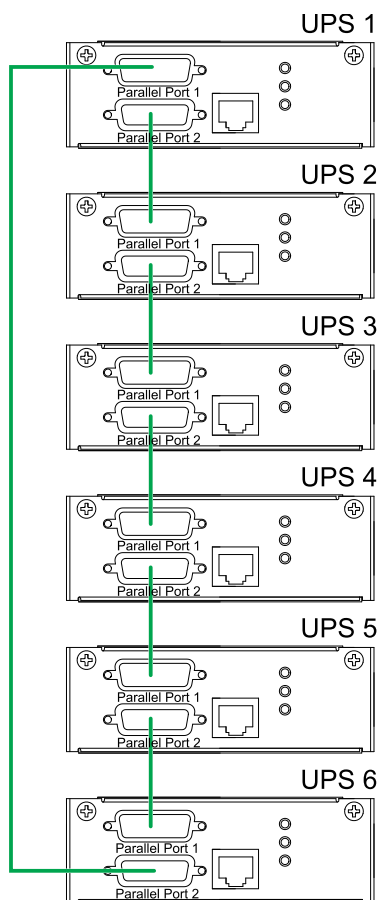

2. Verify the setting of the CAN\_R (for location of CAN\_R see Communication Interfaces, page 37).
  - For parallel systems with  $\leq 4$  parallel UPSs, CAN\_R of all UPSs must be in ON position.
  - For parallel systems with  $\geq 5$  parallel UPSs, CAN\_R of all UPSs must be in OFF position.

# Connect Synchronization Cables Between Two UPS Systems (Option)

The maximum configuration is two parallel systems of four UPSs.

1. Connect the optional synchronization cables between the UPS systems according to the concept below.

## Synchronization Cable Connection for Two Single UPSs

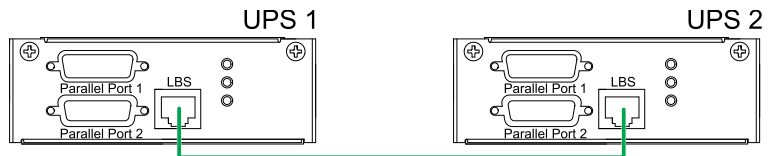

## Synchronization Cable Connection for Two Parallel Systems

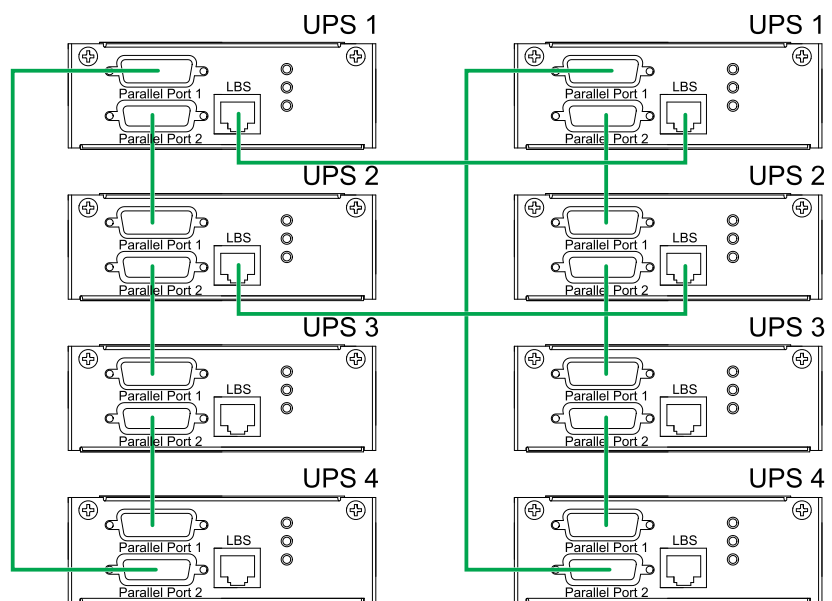

# Backfeed Protection

## **⚠ DANGER**

### **HAZARD OF ELECTRIC SHOCK, EXPLOSION, OR ARC FLASH**

In systems where backfeed protection is not part of the standard design, an automatic isolation device (backfeed protection option or other device meeting the requirements of IEC/EN 62040-1) must be installed to prevent hazardous voltage or energy at the input terminals of the isolation device. The device must open within 15 seconds after the upstream power supply fails and must be rated according to the specifications.

**Failure to follow these instructions will result in death or serious injury.**

When the UPS input is connected through external isolators that, when opened, isolate the neutral or when the automatic backfeed isolation is provided external to the equipment or is connected to an IT power distribution system, a label must be fitted at the UPS input terminals, and on all primary power isolators installed remote from the UPS area and on external access points between such isolators and the UPS, by the user, displaying the following text (or equivalent in a language which is acceptable in the country in which the UPS system is installed):

## **⚠ DANGER**

### **HAZARD OF ELECTRIC SHOCK, EXPLOSION, OR ARC FLASH**

Risk of Voltage Backfeed. Before working on this circuit: Isolate the UPS and check for hazardous voltage between all terminals including the protective earth.

**Failure to follow these instructions will result in death or serious injury.**

An additional external isolation device must be installed in the UPS system. A contactor can be used for this purpose. In the shown examples, the isolation device is a contactor (marked with a **MC1** for single mains systems and marked with a **MC1** and **MC2** for dual mains systems).

The isolation device must be able to withstand the electrical characteristics as described in Specifications, page 16.

**NOTE:** The 24 V source should be generated from the switchgear input source in single mains configurations and from both the switchgear input and bypass source in dual mains configurations.

**NOTE:** The backfeed box in the diagrams is a customized device – please contact Schneider Electric for details.

Single Mains UPS and External Isolation Device

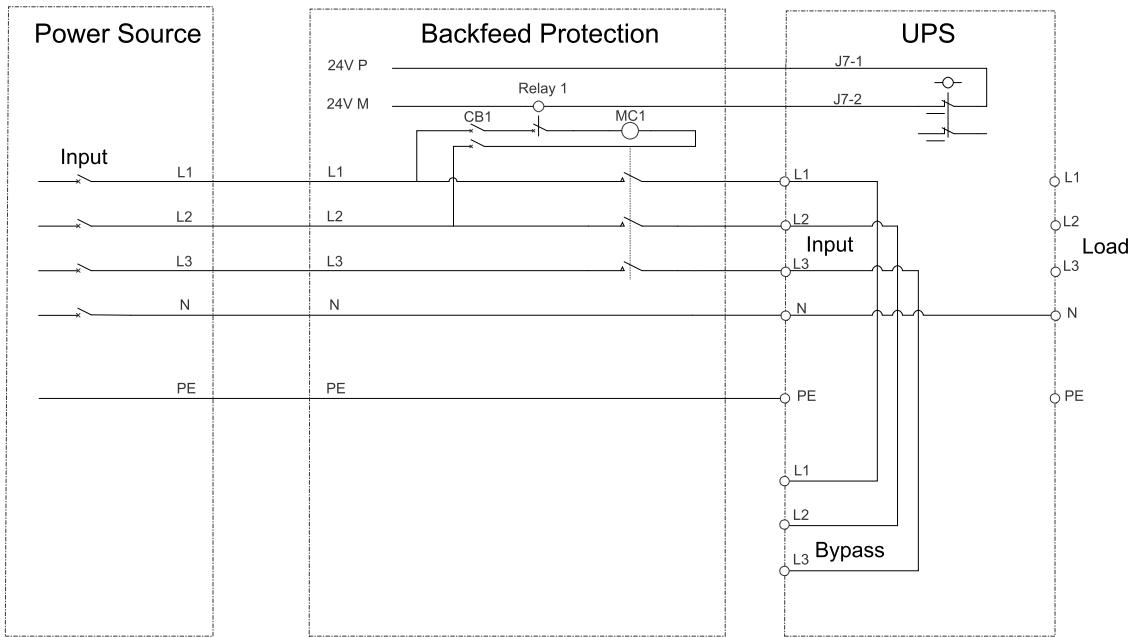

Single Mains UPS with Backfeed Box

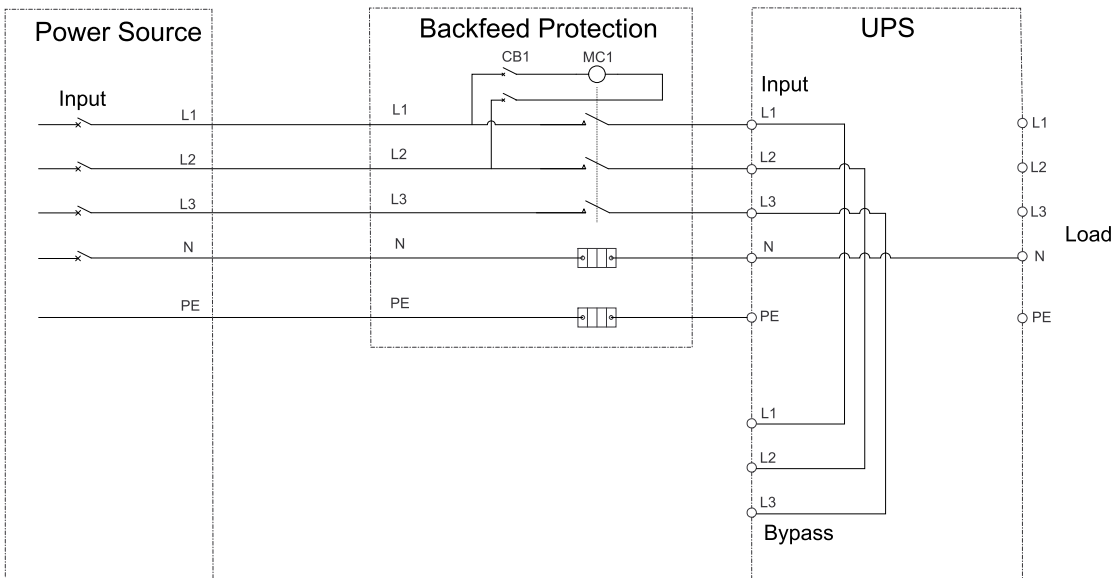

Dual Mains UPS and External Isolation Device

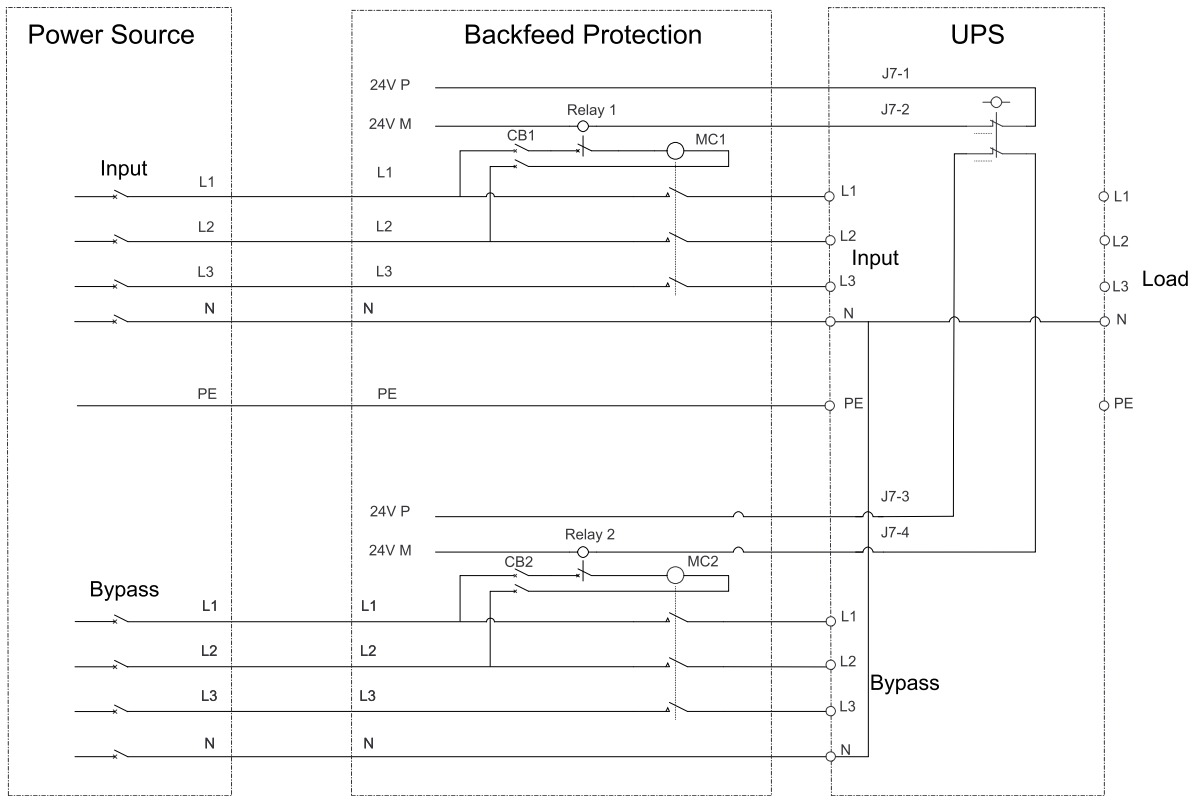

Dual Mains UPS with Backfeed Box

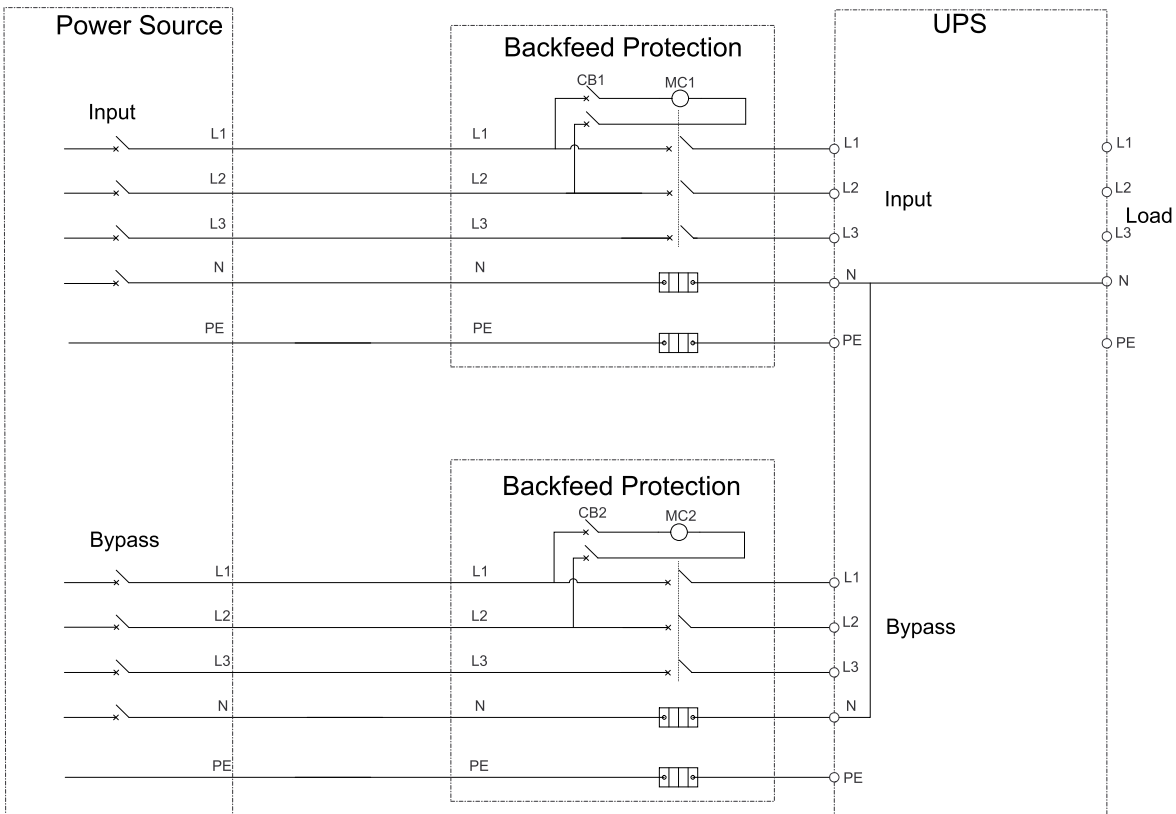

Schneider Electric



\* 9 9 0 - 6 1 3 9 E - 0 0 1 \*

As standards, specifications, and design change from time to time,  
please ask for confirmation of the information given in this publication.

© 2019 – 2024 Schneider Electric. All rights reserved.

990-6139E-001