

Easy UPS 3S for Internal Batteries

10-40 kVA 208 V UL

Installation

Latest updates are available on the Schneider Electric website
11/2023

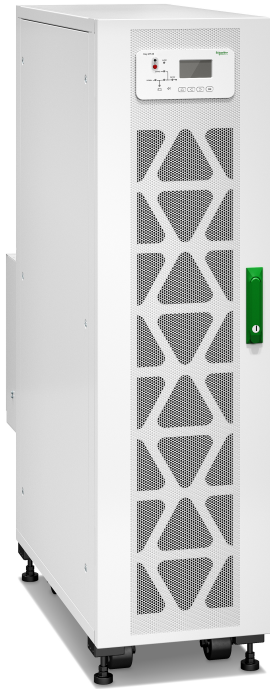

Legal Information

The information provided in this document contains general descriptions, technical characteristics and/or recommendations related to products/solutions.

This document is not intended as a substitute for a detailed study or operational and site-specific development or schematic plan. It is not to be used for determining suitability or reliability of the products/solutions for specific user applications. It is the duty of any such user to perform or have any professional expert of its choice (integrator, specifier or the like) perform the appropriate and comprehensive risk analysis, evaluation and testing of the products/solutions with respect to the relevant specific application or use thereof.

The Schneider Electric brand and any trademarks of Schneider Electric SE and its subsidiaries referred to in this document are the property of Schneider Electric SE or its subsidiaries. All other brands may be trademarks of their respective owner.

This document and its content are protected under applicable copyright laws and provided for informative use only. No part of this document may be reproduced or transmitted in any form or by any means (electronic, mechanical, photocopying, recording, or otherwise), for any purpose, without the prior written permission of Schneider Electric.

Schneider Electric does not grant any right or license for commercial use of the document or its content, except for a non-exclusive and personal license to consult it on an "as is" basis.

Schneider Electric reserves the right to make changes or updates with respect to or in the content of this document or the format thereof, at any time without notice.

To the extent permitted by applicable law, no responsibility or liability is assumed by Schneider Electric and its subsidiaries for any errors or omissions in the informational content of this document, as well as any non-intended use or misuse of the content thereof.

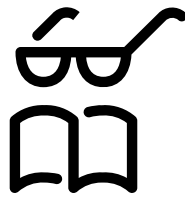

Find the manuals here:
Trouvez les manuels ici:
Encuentre los manuales aquí:



https://www.productinfo.schneider-electric.com/easyups3s_ul/

Table of Contents

Important Safety Instructions — SAVE THESE	
INSTRUCTIONS	7
FCC Statement	8
Safety Precautions	8
Electrical Safety	10
Periodical Check	11
Battery Safety	11
Specifications	13
Input Specifications	13
Bypass Specifications	13
Output Specifications	14
Battery Specifications	14
Required Upstream Protection and Cable Sizes	15
Recommended Upstream Protection	16
Recommended Bolts and Cable Lugs	17
Torque Specifications	17
UPS Weights and Dimensions	18
UPS Shipping Weights and Dimensions	18
Clearance	19
Environmental	20
Heat Dissipation	20
Overview of Single UPS	22
Overview of Parallel System	23
Receiving	24
Remove the UPS from the Pallet	24
Connect the Power Cables	27
Connect the Power Cables in a 10 kVA UPS	27
Connect the Power Cables in a 15-20 kVA UPS	30
Connect the Power Cables in a 30 kVA UPS	33
Connect the Power Cables in a 40 kVA UPS	36
Communication Interfaces	39
Input Contacts and Output Relays	39
Connect the Signal Cables in Parallel Systems	41
Install Batteries in the UPS	42

Important Safety Instructions — SAVE THESE INSTRUCTIONS

Read these instructions carefully and look at the equipment to become familiar with it before trying to install, operate, service or maintain it. The following safety messages may appear throughout this manual or on the equipment to warn of potential hazards or to call attention to information that clarifies or simplifies a procedure.



The addition of this symbol to a “Danger” or “Warning” safety message indicates that an electrical hazard exists which will result in personal injury if the instructions are not followed.



This is the safety alert symbol. It is used to alert you to potential personal injury hazards. Obey all safety messages with this symbol to avoid possible injury or death.

DANGER

DANGER indicates a hazardous situation which, if not avoided, **will result in death or serious injury.**

Failure to follow these instructions will result in death or serious injury.

WARNING

WARNING indicates a hazardous situation which, if not avoided, **could result in death or serious injury.**

Failure to follow these instructions can result in death, serious injury, or equipment damage.

CAUTION

CAUTION indicates a hazardous situation which, if not avoided, **could result in minor or moderate injury.**

Failure to follow these instructions can result in injury or equipment damage.

NOTICE

NOTICE is used to address practices not related to physical injury. The safety alert symbol shall not be used with this type of safety message.

Failure to follow these instructions can result in equipment damage.

Please Note

Electrical equipment should only be installed, operated, serviced, and maintained by qualified personnel. No responsibility is assumed by Schneider Electric for any consequences arising out of the use of this material.

A qualified person is one who has skills and knowledge related to the construction, installation, and operation of electrical equipment and has received safety training to recognize and avoid the hazards involved.

FCC Statement

NOTE: This equipment has been tested and found to comply with the limits for a Class A digital device, pursuant to Part 15 of the FCC Rules. These limits are designed to provide reasonable protection against harmful interference when the equipment is operated in a commercial environment. This equipment generates, uses, and can radiate radio frequency energy and, if not installed and used in accordance with the instruction manual, may cause harmful interference to radio communications. Operation of this equipment in a residential area is likely to cause harmful interference in which case the user will be required to correct the interference at his own expense.

Any changes or modifications not expressly approved by the party responsible for compliance could void the user's authority to operate the equipment.

Safety Precautions

⚠ DANGER

HAZARD OF ELECTRIC SHOCK, EXPLOSION, OR ARC FLASH

All safety instructions in this document must be read, understood and followed.

Failure to follow these instructions will result in death or serious injury.

⚠ DANGER

HAZARD OF ELECTRIC SHOCK, EXPLOSION, OR ARC FLASH

Read all instructions in the Installation Manual before installing or working on this UPS system.

Failure to follow these instructions will result in death or serious injury.

⚠ DANGER

HAZARD OF ELECTRIC SHOCK, EXPLOSION, OR ARC FLASH

Do not install the UPS system until all construction work has been completed and the installation room has been cleaned.

Failure to follow these instructions will result in death or serious injury.

⚠ DANGER

HAZARD OF ELECTRIC SHOCK, EXPLOSION, OR ARC FLASH

- The product must be installed according to the specifications and requirements as defined by Schneider Electric. It concerns in particular the external and internal protections (upstream breakers, battery breakers, cabling, etc.) and environmental requirements. No responsibility is assumed by Schneider Electric if these requirements are not respected.
- After the UPS system has been electrically wired, do not start up the system. Start-up must only be performed by Schneider Electric.

Failure to follow these instructions will result in death or serious injury.

⚠ DANGER

HAZARD OF ELECTRIC SHOCK, EXPLOSION, OR ARC FLASH

The UPS system must be installed according to local and national regulations. Install the UPS according to:

- IEC 60364 (including 60364-4-41 - protection against electric shock, 60364-4-42 - protection against thermal effect, and 60364-4-43 - protection against overcurrent), or
- NEC NFPA 70, or
- Canadian Electrical Code (C22.1, Part 1)

depending on which one of the standards apply in your local area.

Failure to follow these instructions will result in death or serious injury.

⚠ DANGER

HAZARD OF ELECTRIC SHOCK, EXPLOSION, OR ARC FLASH

- Install the UPS system in a temperature controlled indoor environment free of conductive contaminants and humidity.
- Install the UPS system on a non-flammable, level and solid surface (e.g. concrete) that can support the weight of the system.

Failure to follow these instructions will result in death or serious injury.

⚠ DANGER

HAZARD OF ELECTRIC SHOCK, EXPLOSION, OR ARC FLASH

The UPS is not designed for and must therefore not be installed in the following unusual operating environments:

- Damaging fumes
- Explosive mixtures of dust or gases, corrosive gases, or conductive or radiant heat from other sources
- Moisture, abrasive dust, steam or in an excessively damp environment
- Fungus, insects, vermin
- Salt-laden air or contaminated cooling refrigerant
- Pollution degree higher than 2 according to IEC 60664-1
- Exposure to abnormal vibrations, shocks, and tilting
- Exposure to direct sunlight, heat sources, or strong electromagnetic fields

Failure to follow these instructions will result in death or serious injury.

⚠ DANGER

HAZARD OF ELECTRIC SHOCK, EXPLOSION, OR ARC FLASH

Do not drill or cut holes for cables or conduits with the gland plates installed and do not drill or cut holes in close proximity to the UPS.

Failure to follow these instructions will result in death or serious injury.

⚠ WARNING

HAZARD OF ARC FLASH

Do not make mechanical changes to the product (including removal of cabinet parts or drilling/cutting of holes) that are not described in the Installation Manual.

Failure to follow these instructions can result in death, serious injury, or equipment damage.

NOTICE**RISK OF OVERHEATING**

Respect the space requirements around the UPS system and do not cover the product's ventilation openings when the UPS system is in operation.

Failure to follow these instructions can result in equipment damage.

NOTICE**RISK OF EQUIPMENT DAMAGE**

The UPS must use an external regenerative braking kit to dissipate energy when connected to regenerative loads including photovoltaic systems and speed drives.

Failure to follow these instructions can result in equipment damage.

Electrical Safety**⚠ DANGER****HAZARD OF ELECTRIC SHOCK, EXPLOSION OR ARC FLASH**

- Electrical equipment must be installed, operated, serviced, and maintained only by qualified personnel.
- The UPS system must be installed in a room with restricted access (qualified personnel only).
- Apply appropriate personal protective equipment (PPE) and follow safe electrical work practices.
- Turn off all power supplying the UPS system before working on or inside the equipment.
- Before working on the UPS system, check for hazardous voltage between all terminals including the protective earth.
- The UPS contains an internal energy source. Hazardous voltage can be present even when disconnected from the utility/mains supply. Before installing or servicing the UPS system, ensure that the units are OFF and that utility/mains and batteries are disconnected. Wait five minutes before opening the UPS to allow the capacitors to discharge.
- A disconnection device (e.g. disconnection circuit breaker or switch) must be installed to enable isolation of the system from upstream power sources in accordance with local regulations. This disconnection device must be easily accessible and visible.
- The UPS must be properly earthed/grounded and due to a high leakage current, the earthing/grounding conductor must be connected first.

Failure to follow these instructions will result in death or serious injury.

⚠ DANGER**HAZARD OF ELECTRIC SHOCK, EXPLOSION, OR ARC FLASH**

In systems where backfeed protection is not part of the standard design, an automatic isolation device (backfeed protection option or other device meeting the requirements of IEC/EN 62040-1 or UL1778 5th Edition – depending on which of the two standards apply to your local area) must be installed to prevent hazardous voltage or energy at the input terminals of the isolation device. The device must open within 15 seconds after the upstream power supply fails and must be rated according to the specifications.

Failure to follow these instructions will result in death or serious injury.

When the UPS input is connected through external isolators that, when opened, isolate the neutral or when the automatic backfeed isolation is provided external to the equipment or is connected to an IT power distribution system, a label must be fitted at the UPS input terminals, and on all primary power isolators installed remote from the UPS area and on external access points between such isolators and the UPS, by the user, displaying the following text (or equivalent in a language which is acceptable in the country in which the UPS system is installed):

⚠ DANGER
HAZARD OF ELECTRIC SHOCK, EXPLOSION, OR ARC FLASH
Risk of Voltage Backfeed. Before working on this circuit: Isolate the UPS and check for hazardous voltage between all terminals including the protective earth.
Failure to follow these instructions will result in death or serious injury.

Periodical Check

⚠ WARNING
HAZARD OF ELECTRIC SHOCK, EXPLOSION OR ARC FLASH
<ul style="list-style-type: none">• Limited lifetime components, such as capacitors, fans, electronic boards, batteries, etc., must be checked periodically by qualified personnel.• Battery trip control must be done periodically by qualified personnel.
This periodical check is recommended every 6 months and required every 12 months.
Failure to follow these instructions can result in death, serious injury, or equipment damage.

Battery Safety

⚠⚠ DANGER
HAZARD OF ELECTRIC SHOCK, EXPLOSION, OR ARC FLASH
<ul style="list-style-type: none">• Battery circuit breakers must be installed according to the specifications and requirements as defined by Schneider Electric.• Servicing of batteries must only be performed or supervised by qualified personnel knowledgeable of batteries and the required precautions. Keep unqualified personnel away from batteries.• Disconnect charging source prior to connecting or disconnecting battery terminals.• Do not dispose of batteries in a fire as they can explode.• Do not open, alter, or mutilate batteries. Released electrolyte is harmful to the skin and eyes. It may be toxic.
Failure to follow these instructions will result in death or serious injury.

⚡⚠ DANGER**HAZARD OF ELECTRIC SHOCK, EXPLOSION, OR ARC FLASH**

Batteries can present a risk of electric shock and high short-circuit current. The following precautions must be observed when working on batteries

- Remove watches, rings, or other metal objects.
- Use tools with insulated handles.
- Wear protective glasses, gloves and boots.
- Do not lay tools or metal parts on top of batteries.
- Disconnect the charging source prior to connecting or disconnecting battery terminals.
- Determine if the battery is inadvertently grounded. If inadvertently grounded, remove source from ground. Contact with any part of a grounded battery can result in electric shock. The likelihood of such shock can be reduced if such grounds are removed during installation and maintenance (applicable to equipment and remote battery supplies not having a grounded supply circuit).

Failure to follow these instructions will result in death or serious injury.

⚡⚠ DANGER**HAZARD OF ELECTRIC SHOCK, EXPLOSION, OR ARC FLASH**

When replacing batteries, always replace with the same type and number of batteries or battery packs.

Failure to follow these instructions will result in death or serious injury.

⚠ CAUTION**RISK OF EQUIPMENT DAMAGE**

- Mount the batteries in the UPS system, but do not connect the batteries until the UPS system is ready to be powered up. The time duration from battery connection until the UPS system is powered up must not exceed 72 hours or 3 days.
- Batteries must not be stored more than six months due to the requirement of recharging. If the UPS system remains de-energized for a long period, we recommend that you energize the UPS system for a period of 24 hours at least once every month. This charges the batteries, thus avoiding irreversible damage.

Failure to follow these instructions can result in injury or equipment damage.

Specifications

Input Specifications

	10 kVA		15 kVA		20 kVA		30 kVA		40 kVA	
Voltage (V)	208	220	208	220	208	220	208	220	208	220
Connections	L1, L2, L3, N, G									
Input voltage range (V)	176–253									
Frequency range (Hz)	40–70									
Nominal input current (A)	31	30	46	44	61	58	92	86	120	113
Maximum input current (A)	37	35	54	51	72	69	107	102	143	136
Input current limitation (A)	58		85		114		169		225	
Total harmonic distortion (THDI)	≤4% at 100% linear load (symmetrical)									
Input power factor	≥0.99 at loads >75%									
Maximum short circuit rating	10 kA RMS symmetrical									
Protection	Built-in backfeed protection and fuses									
Ramp-in	30 seconds									

Bypass Specifications

	10 kVA		15 kVA		20 kVA		30 kVA		40 kVA	
Voltage (V)	208	220	208	220	208	220	208	220	208	220
Connections	L1, L2, L3, N, G									
Overload capacity	110% continuous 125% for 10 minutes 150% for 1 minute >150% for 300 milliseconds									
Minimum bypass voltage (V)	125	132	125	132	125	132	125	132	125	132
Maximum bypass voltage (V)	260	275	260	275	260	275	260	275	260	275
Frequency (Hz)	50 or 60									
Frequency range (Hz)	±1, ±3, ±5 (user selectable)									
Nominal bypass current (A)	29	28	43	41	57	54	86	81	113	107
Maximum short circuit rating	10 kA RMS symmetrical									
Protection	Built-in backfeed protection									

Output Specifications

Voltage (V)	10 kVA		15 kVA		20 kVA		30 kVA		40 kVA	
	208	220	208	220	208	220	208	220	208	220
Connections	L1, L2, L3, N, G									
Overload capacity	110% for 60 minutes 125% for 10 minutes 150% for 1 minute >150% for less than 200 milliseconds									
Output voltage regulation	± 1% at symmetrical load									
Dynamic load response	± 5% after 20 milliseconds									
Output power factor	1.0									
Nominal output current (A)	28	26	42	40	56	52	83	79	111	105
Total harmonic distortion (THDU)	<1.5% at 100% linear load <6% at 100% non-linear load									
Output frequency (Hz)	50/60 Hz bypass synchronized – 50/60 Hz ± 0.1% free-running									
Output performance classification (according to IEC62040-3)	VFI-SS-121									
Load power factor	From 0.7 leading to 0.7 lagging without derating									
Load crest factor	2.5:1									

Battery Specifications

	10 kVA	15 kVA	20 kVA	30 kVA	40 kVA
Charging power	Programmable from 1% to 15% of UPS capacity. Default is 10%.				
Maximum charging power (W)	1500	2250	3000	4500	6000
Nominal battery voltage (20 blocks) (VDC)	± 120				
Nominal float voltage (20 blocks) (VDC)	± 136				
End of discharge voltage (20 blocks) (≥ 3C) (VDC)	± 96				
End of discharge voltage (20 blocks) (≤ 0.05C) (VDC)	± 105				
Battery current at full load and nominal battery voltage (20 blocks) (A)	46	68	91	136	182
Battery current at full load and minimum battery voltage (20 blocks) (A)	57	85	114	170	227
Temperature compensation (per cell)	Programmable from 0 to 5 mV. Default is 3 mV if the battery temperature is above 25 °C (77 °F).				
Ripple current	< 5% C20				
Battery test	Manual/automatic (selectable)				

Required Upstream Protection and Cable Sizes

⚠️⚠️ DANGER

HAZARD OF ELECTRIC SHOCK, EXPLOSION, OR ARC FLASH

All wiring must comply with all applicable national and/or electrical codes. The maximum allowable cable size is 4/0 AWG.

Failure to follow these instructions will result in death or serious injury.

NOTE: Overcurrent protection and cable lugs are to be provided by others. Cable sizes in this manual are based on Table 310.15 (B)(16) of the National Electrical Code (NEC) with the following assertions:

- 90 °C (194 °F) conductors (75 °C (167 °F) termination)
- An ambient temperature of 30 °C (86 °F)
- Use of copper conductors
- Installation method C

If the ambient temperature is greater than 30 °C (86 °F), larger conductors are to be selected in accordance with the correction factors of the NEC.

Equipment grounding conductors (EGC) are sized in accordance with NEC Article 250.122 and Table 250.122.

NOTE: The battery cable sizes given here are recommendations. Always follow the specific instructions in the battery solution documentation for battery +/- and battery EGC cable sizes.

NOTE: Neutral conductor is sized to handle 1.73 times phase current in case of high harmonic content from non-linear loads. If few or no harmonic currents are expected, neutral conductor can be sized as phase conductor. In dual mains systems, the input neutral conductor can be sized as the input phase conductor.

UPS rating	10 kVA	15 kVA	20 kVA	30 kVA	40 kVA
Input phases (AWG/kcmil)	8	6	4	1	2/0
Input EGC (AWG/kcmil)	10	8	8	6	6
Bypass/output phases (AWG/kcmil)	8	6	4	1	2/0
Bypass EGC/output EGC (AWG/kcmil)	10	8	8	6	6
Neutral (AWG/kcmil)	4	3	1/0	2x1/0	2x2/0
Battery +/-/N (AWG/kcmil)	4/0	4/0	4/0	4/0	4/0
Battery EGC (AWG/kcmil)	10	8	8	6	6

Recommended Upstream Protection

⚠ CAUTION

HAZARD OF FIRE

- Connect only to a circuit with the below specifications.
- Connect to a circuit provided with a 175 A branch circuit overcurrent protection maximum in accordance with the National Electric Code, ANSI/NFPA70, and the Canadian Electrical Code, Part I, C22.1.

Failure to follow these instructions can result in injury or equipment damage.

NOTE: Overcurrent protection is to be provided by others and marked with its function.

NOTE: For IT systems or resistance grounding systems, a 4-pole circuit breaker must be installed.

NOTE: For local directives which require 4-pole circuit breakers: If neutral conductor is expected to carry a high current, due to line-neutral non-linear load, the circuit breaker must be rated according to expected neutral current.

UPS rating	Source	Breaker rating (Ir)	Breaker type	Ii (x In) setting
10 kVA	Input	45 A	BDF36045	400 A fixed
	Bypass	35 A	BDF36035	400 A fixed
15 kVA	Input	70 A	BGF36070	640 A fixed
	Bypass	60 A	BGF36060	640 A fixed
20 kVA	Input	90 A	BGF36090	1000 A fixed
	Bypass	70 A	BGF36070	640 A fixed
30 kVA	Input	110 A	HGF36110C	1250
	Bypass	90 A	HGF36090C	1250
40 kVA	Input	150 A	HJF36150C	1250
	Bypass	125 A	HJF36125C	1250

Recommended Bolts and Cable Lugs

NOTICE

RISK OF EQUIPMENT DAMAGE

Use only UL approved compression cable lugs.

Failure to follow these instructions can result in equipment damage.

UPS rating		10 kVA	15 kVA	20 kVA	30 kVA	40 kVA
Ground/EGC	Cable size (AWG/kcmil)	10	8	8	6	6
	Bolt size	M6	M6	M6	M8	M6
	Cable lug type	LCA10-14-L	LCA8-14-L	LCA8-14-L	LCA6-56-L	LCA6-56-L
Input/bypass/output	Cable size (AWG/kcmil)	8	6	4	1	2/0
	Bolt size	M6	M8	M8	M8	M10
	Cable lug type	LCA8-14-L	LCA6-56-L	LCA4-56-L	LCA1-56-E	LCA2/0-38-X
Neutral	Cable size (AWG/kcmil)	4	3	1/0	2x1/0	2x2/0
	Bolt size	M6	M8	M8	M10	M10
	Cable lug type	LCAN4-14-L-01	LCA3-56-L	LCA1/0-56-X	LCA1/0-56-X	LCA2/0-38-X
Battery	Cable size (AWG/kcmil)	4/0	4/0	4/0	4/0	4/0
	Bolt size	M10	M10	M10	M10	M10
	Cable lug type	LCA4/0-38-X	LCA4/0-38-X	LCA4/0-38-X	LCA4/0-38-X	LCA4/0-38-X

Torque Specifications

UPS rating	Bolt Size	Torque
10 kVA	M6	5.59 Nm (4.12 lb-ft)
	M10	15 Nm (11.06 lb-ft)
15 kVA/20 kVA	M8	5.59 Nm (4.12 lb-ft)
	M10	15 Nm (11.06 lb-ft)
30 kVA	M8	12 Nm (8.85 lb-ft)
	M10	15 Nm (11.06 lb-ft)
40 kVA	M10	15 Nm (11.06 lb-ft)

UPS Weights and Dimensions

UPS rating	Weight kg (lbs)	Height mm (in)	Width mm (in)	Depth mm (in)
10 kVA	120 (265) ¹	1400 (55.12)	380 (14.97)	960 (37.80)
15 kVA	132 (291) ¹	1400 (55.12)	380 (14.97)	960 (37.80)
20 kVA	132 (291) ¹	1400 (55.12)	380 (14.97)	960 (37.80)
30 kVA	155 (342) ¹	1400 (55.12)	380 (14.97)	1050 (41.34)
40 kVA	187 (412) ¹	1400 (55.12)	500 (19.69)	1092 (43.00)

UPS Shipping Weights and Dimensions

UPS rating	Weight kg (lbs)	Height mm (in)	Width mm (in)	Depth mm (in)
10 kVA	152 (335)	1595 (62.80)	800 (31.50)	1200 (47.24)
15 kVA	165 (364)	1595 (62.80)	800 (31.50)	1200 (47.24)
20 kVA	165 (364)	1595 (62.80)	800 (31.50)	1200 (47.24)
30 kVA	188 (414)	1595 (62.80)	800 (31.50)	1200 (47.24)
40 kVA	220 (485)	1595 (62.80)	800 (31.50)	1200 (47.24)

1. Weight without batteries. Each battery module weighs 27 kg (60 lbs).

Clearance

NOTE: Clearance dimensions are published for airflow and service access only. Consult with the local safety codes and standards for additional requirements in your local area.

NOTE: If the UPS is installed without side access (Option A*), the length of the cables connected to the UPS must allow for rolling out the UPS.

For the United States

Option A*

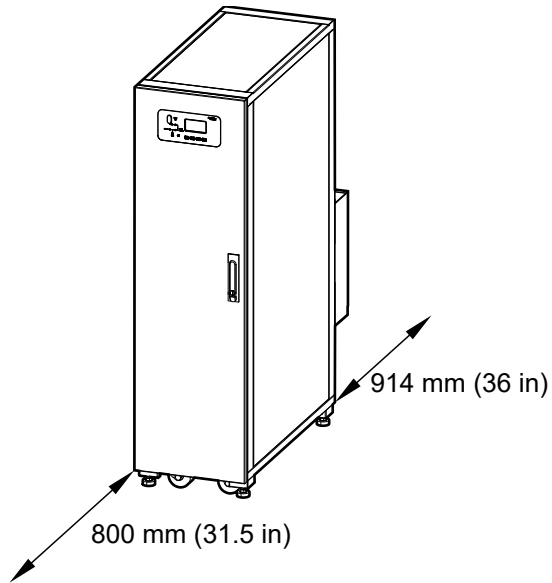

Option B

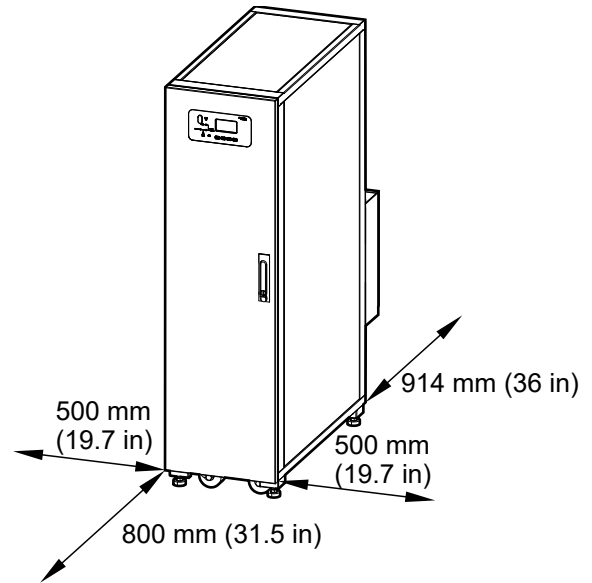

For Other Regions and Countries

Option A*

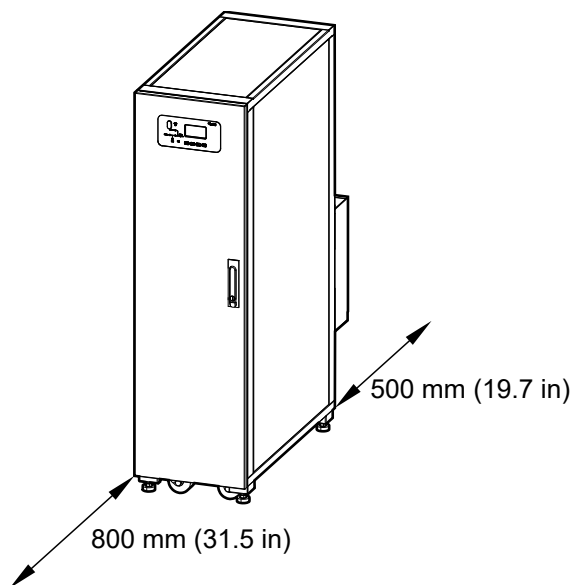

Option B

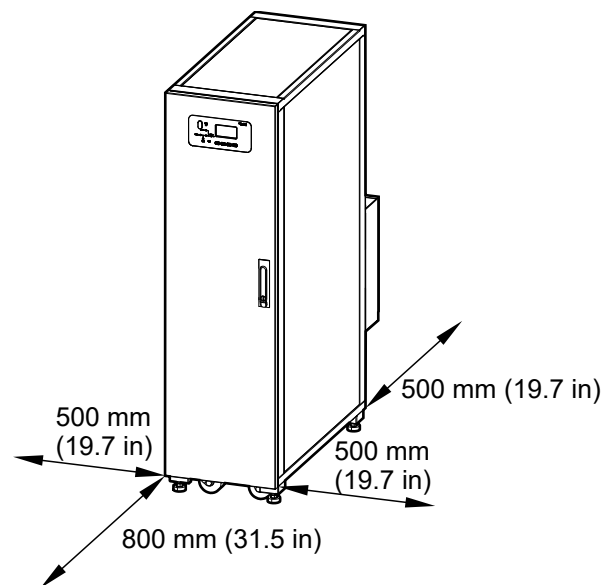

Environmental

	Operation	Storage
Temperature	0 °C to 40 °C (32 °F to 104 °F) ²	-15 °C to 40 °C (5 °F to 104 °F) for systems with batteries -25 °C to 55 °C (-13 °F to 131 °F) for systems without batteries
Relative humidity	0–95% non-condensing	
Elevation derating according to IEC 62040–3	Designed for operation in 0-2000 m (0-6600 feet) elevation. Power derating required from 1000-2000 m: Up to 1000 m (3300 feet): 1.000 Up to 1500 m (5000 feet): 0.975 Up to 2000 m (6600 feet): 0.950	< 15000 m (50000 feet) above sea level (or in an environment with equivalent air pressure)
Audible noise	10 kVA: ≤65 dBA at full load 15-30 kVA: ≤68 dBA at full load 40 kVA: ≤70 dBA at full load	
Protection class	IP20 (dust filter as standard)	
Color	RAL 9003	

Heat Dissipation

	10 kVA	15 kVA	20 kVA	30 kVA	40 kVA
Normal mode (W)	700	1050	1400	2100	2800
Battery mode (W)	750	1125	1500	2250	3000
ECO mode (W)	200	300	400	600	800

2. The optimal operation temperature for batteries is 20 °C to 25 °C (68 °F to 77 °F)

Overview of Single UPS

UIB	Unit input breaker
SSIB	Static switch input breaker
UOB	Unit output breaker
MBB	Maintenance bypass breaker
BB	Battery relay

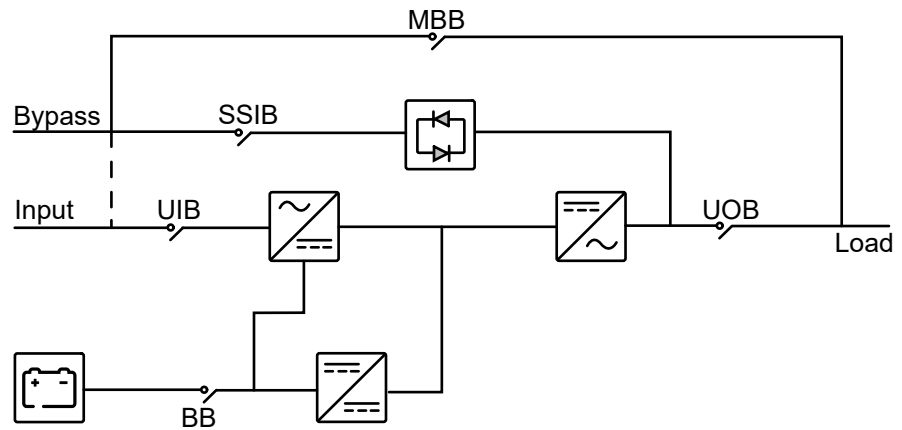

Overview of Parallel System

NOTE: In parallel systems with an external maintenance bypass breaker Ext. MBB, the maintenance bypass breakers MBB must be padlocked in the open position.

MIB	Mains input breaker
BIB	Bypass input breaker
UIB	Unit input breaker
SSIB	Static switch input breaker
UOB	Unit output breaker
Ext. UOB	External unit output breaker
MBB	Maintenance bypass breaker
Ext. MBB	External maintenance bypass breaker
SIB	System isolation breaker
BB	Battery relay

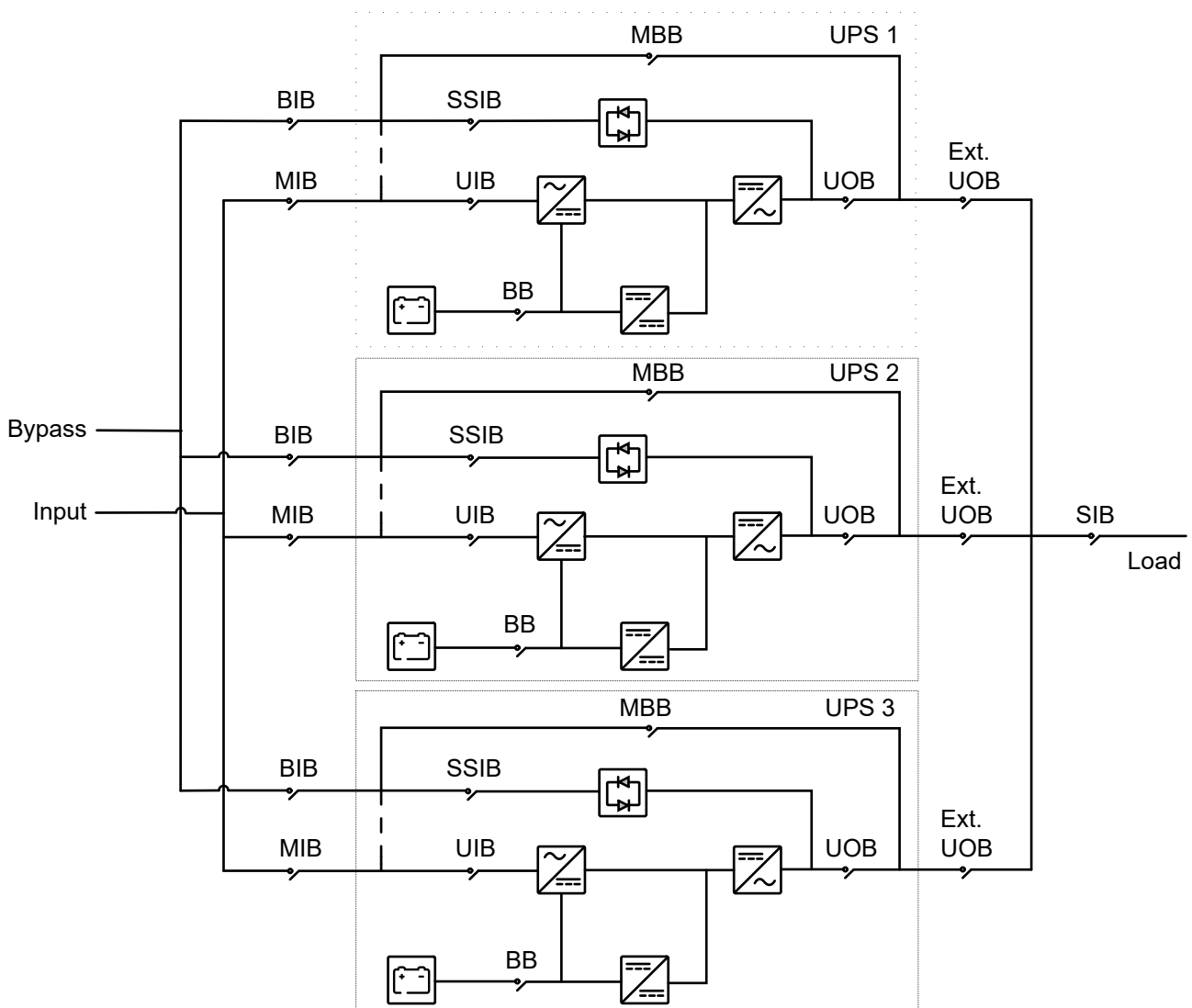

Receiving

External Inspection

When the shipment arrives, inspect the shipping material for any signs of damage or mishandling. Do not attempt to install the system if a damage is apparent. If any damage is noted, contact Schneider Electric and file a damage claim with the shipping agency within 24 hours.

Compare the components of the shipment with the bill of lading. Report any missing items to the carrier and to Schneider Electric immediately.

Verify that labelled units match the order confirmation.

Remove the UPS from the Pallet

1. Move the UPS to the final installation area using a forklift or the pallet jack.
2. Remove the shipping materials and the ramp from the UPS.

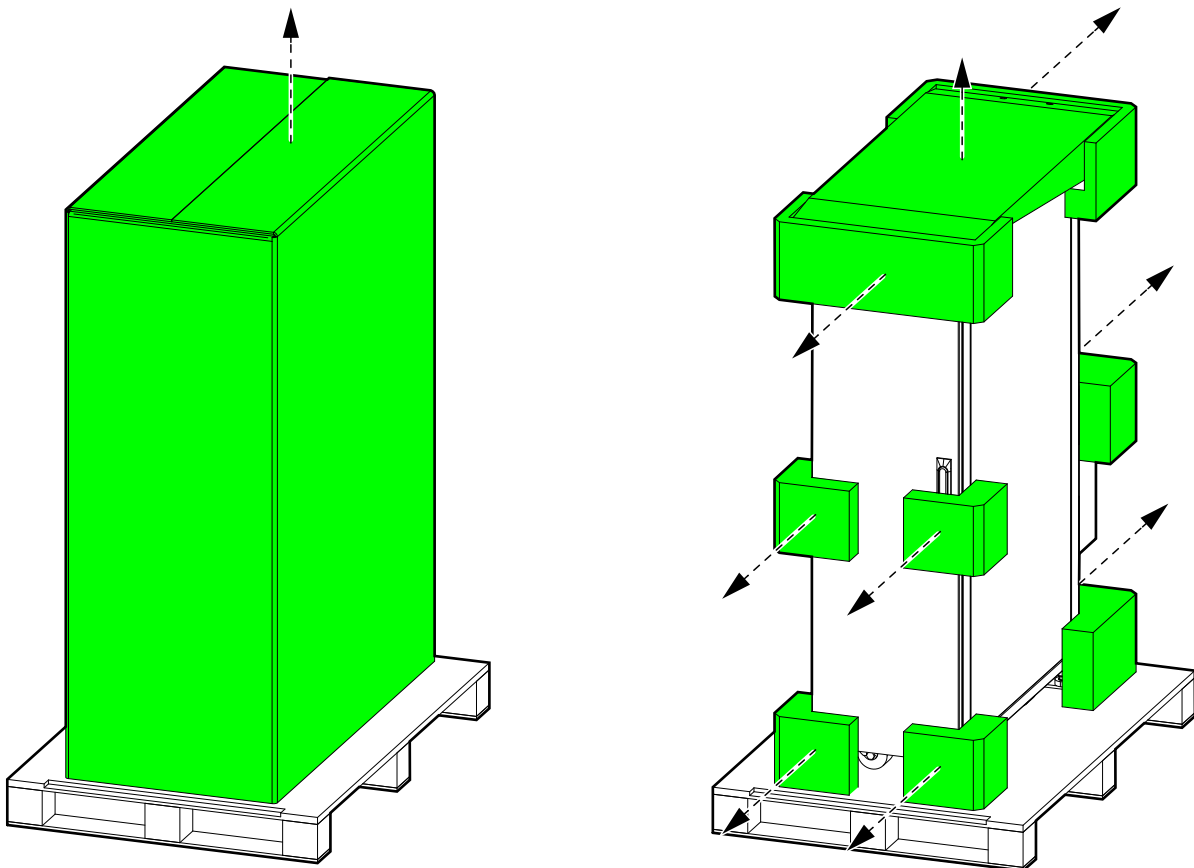

3. Loosen the bolts and remove the shipping brackets.

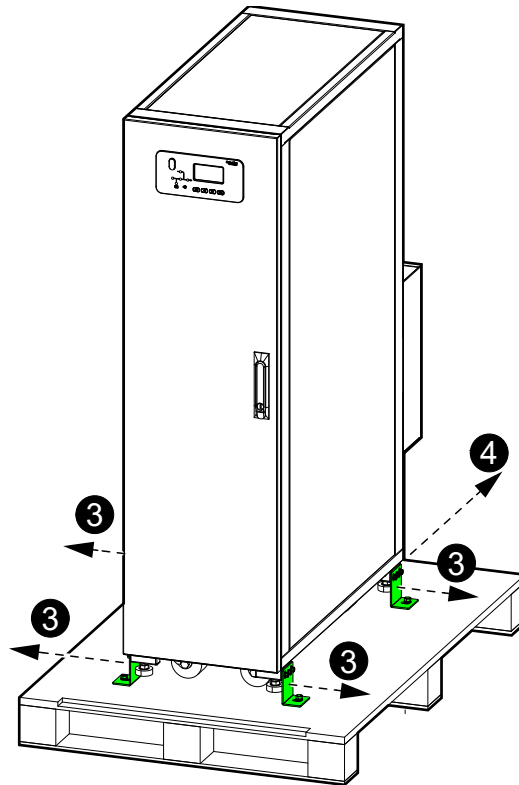

4. Remove the bracket from the rear of the UPS. Save for reinstallation.
5. Place the ramp and fasten it to the pallet with the bolts from the shipping bracket.

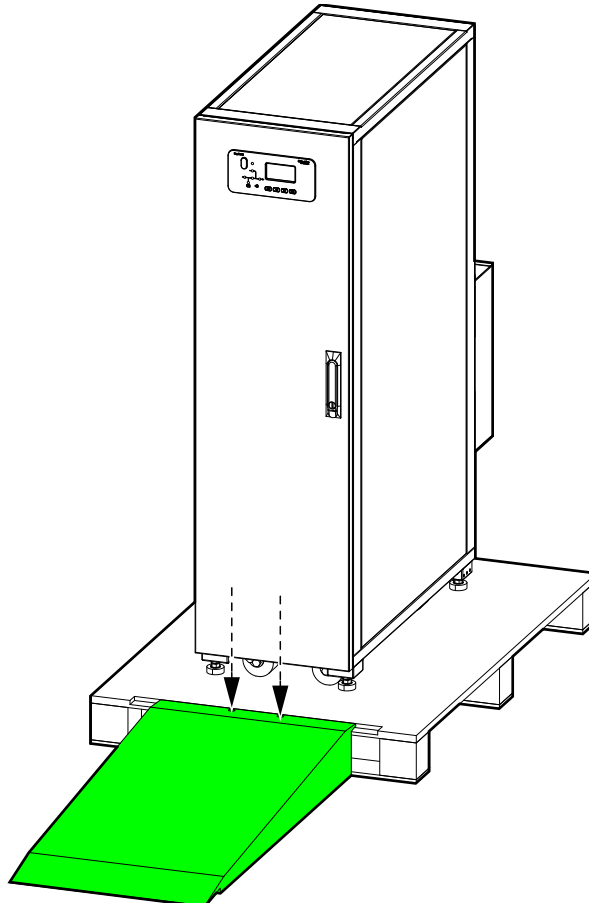

6. Roll the UPS down from the pallet.

7. Move the UPS to its final location and use a wrench to lower the leveling feet. Ensure that the cabinet is level.

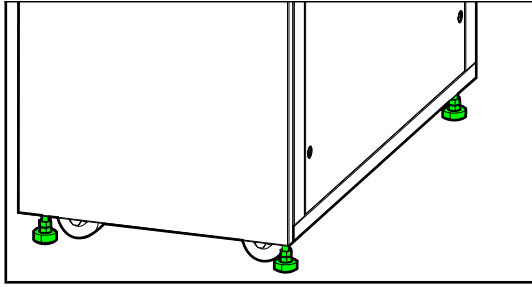

8. For the 10-30 kVA UPSs reinstall the bracket on the rear side and fasten to the floor.

Rear View of UPS

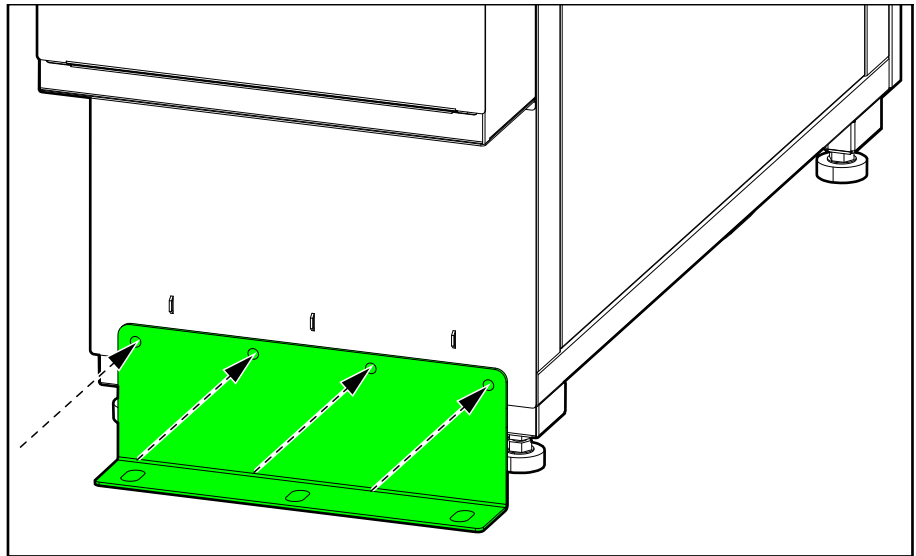

Connect the Power Cables

Connect the Power Cables in a 10 kVA UPS

1. Ensure that all breakers are in the OFF (open) position.
2. Remove the conduit box cover.

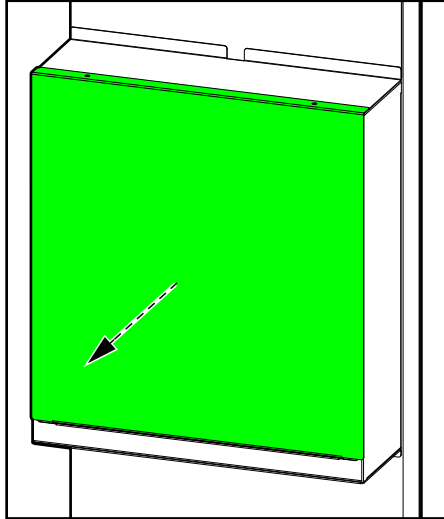

3. Remove the two terminal covers.

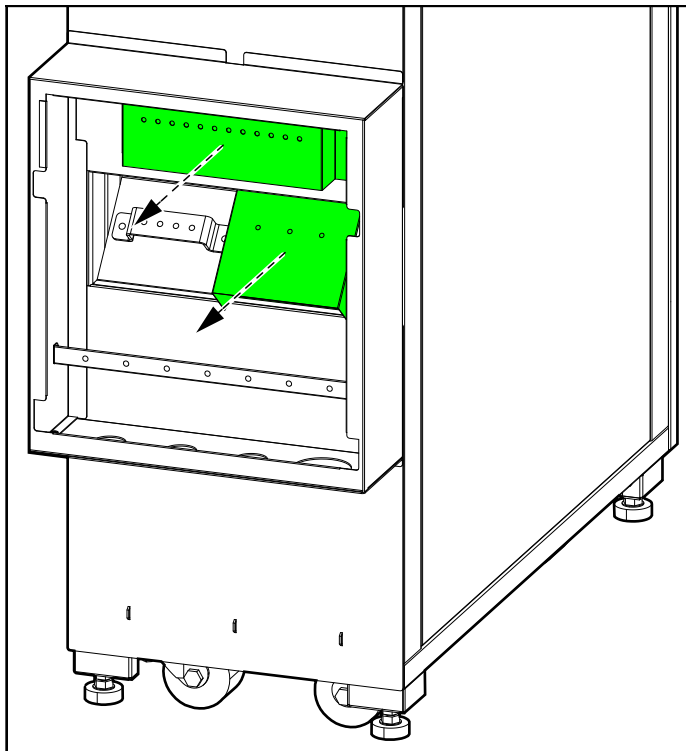

- In dual mains systems, remove the three single mains jumpers.

NOTE: Save these jumpers for future service visit use by Schneider Electric.

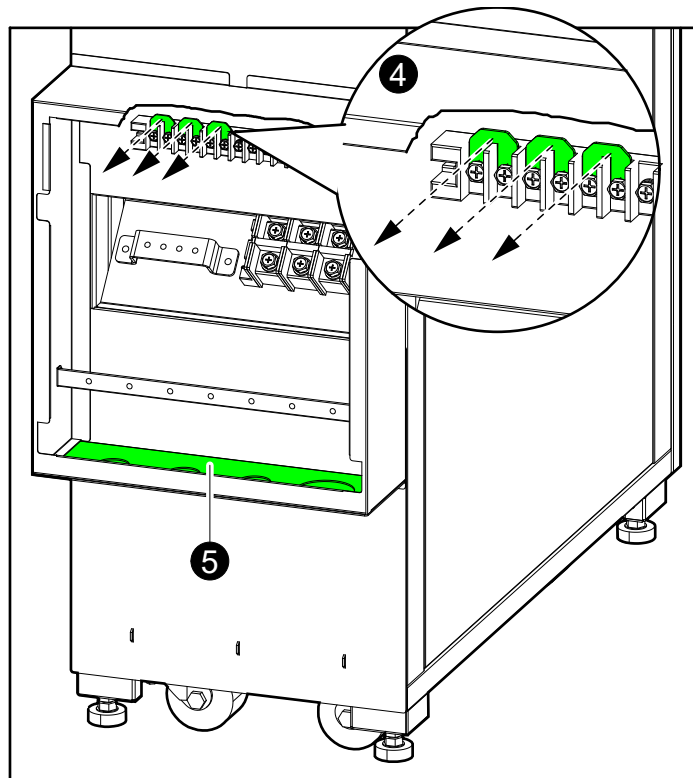

- Remove the gland plate from the bottom of the conduit box. Drill or cut holes in the gland plate for cables/conduits. Install conduits (if applicable) and reinstall the gland plate.

⚡ ⚠ DANGER

HAZARD OF ELECTRIC SHOCK, EXPLOSION, OR ARC FLASH

Do not drill or cut holes for cables or conduits with the gland plate installed and do not drill or cut holes in close proximity to the UPS.

Failure to follow these instructions will result in death or serious injury.

- Route the power cables through the bottom of the conduit box.

7. Connect the equipment grounding conductor.

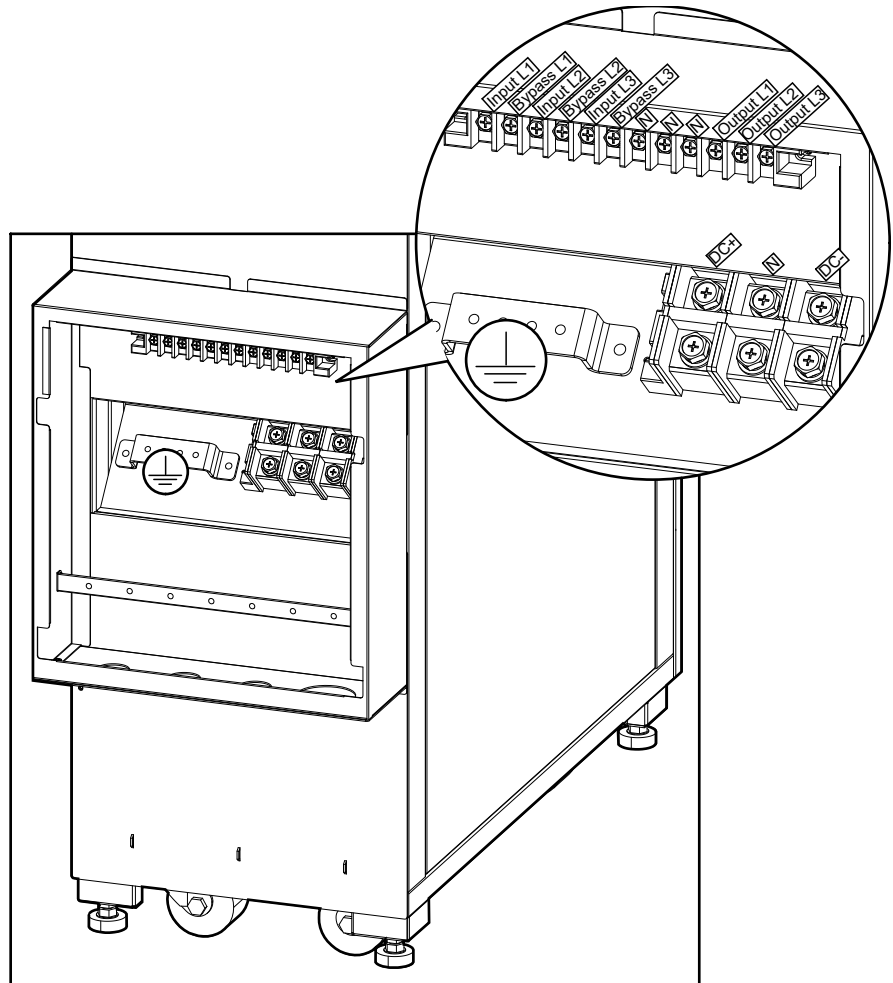

8. Connect the input cables (L1, L2, L3, N).
9. Connect the output cables (L1, L2, L3, N).
10. Connect the bypass cables (L1, L2, L3, N) (if applicable).
11. Connect the battery cables (DC+, DC-, N).
12. Reinstall the terminal covers and the conduit box cover.

Connect the Power Cables in a 15-20 kVA UPS

1. Ensure that all breakers are in the OFF (open) position.
2. Remove the conduit box cover.

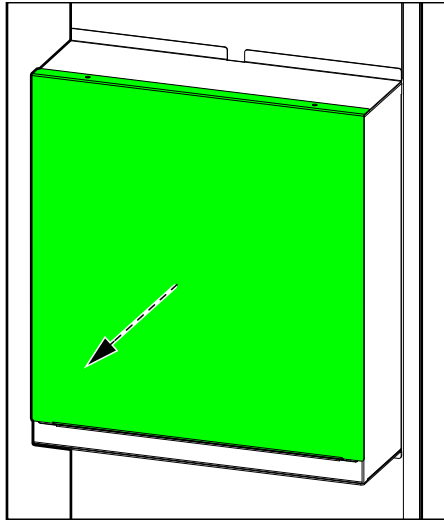

3. Remove the two terminal covers.

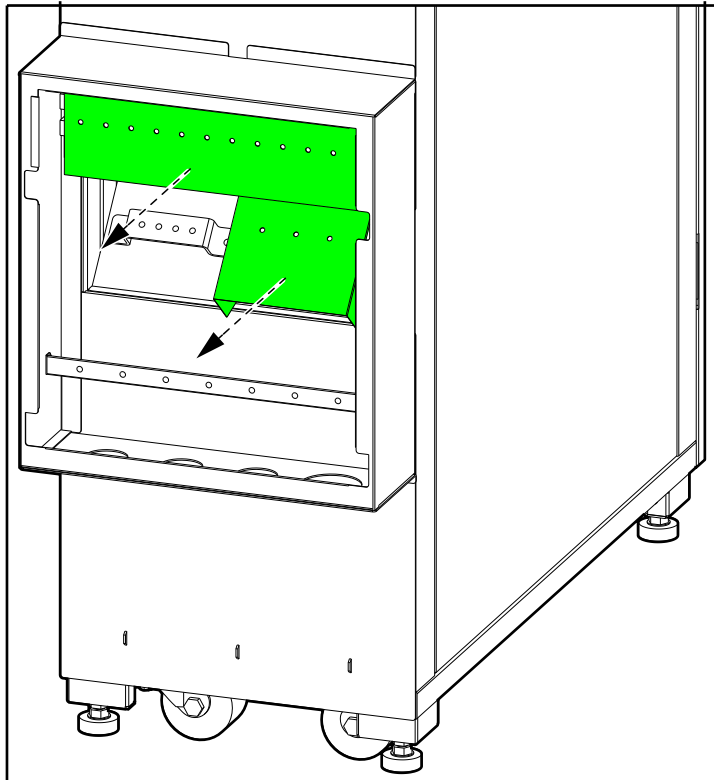

- In dual mains systems, remove the three single mains jumpers.

NOTE: Save these jumpers for future service visit use by Schneider Electric.

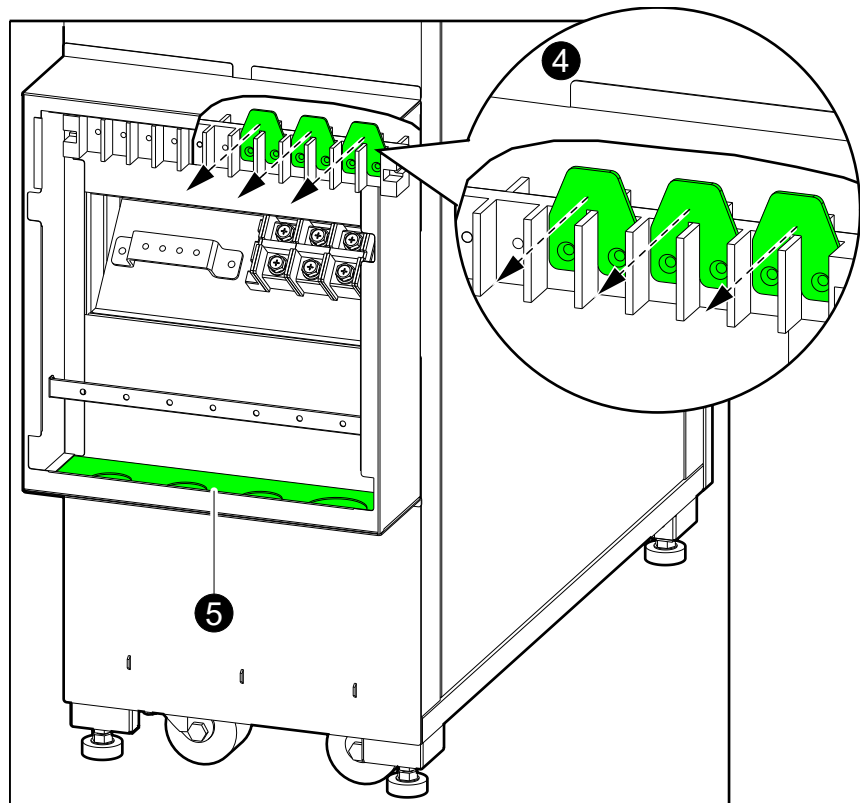

- Remove the gland plate from the bottom of the conduit box. Drill or cut holes in the gland plate for cables/conduits. Install conduits (if applicable) and reinstall the gland plate.

⚡ ⚠ DANGER

HAZARD OF ELECTRIC SHOCK, EXPLOSION, OR ARC FLASH

Do not drill or cut holes for cables or conduits with the gland plate installed and do not drill or cut holes in close proximity to the UPS.

Failure to follow these instructions will result in death or serious injury.

- Route the power cables through the bottom of the conduit box.

7. Connect the equipment grounding conductor.

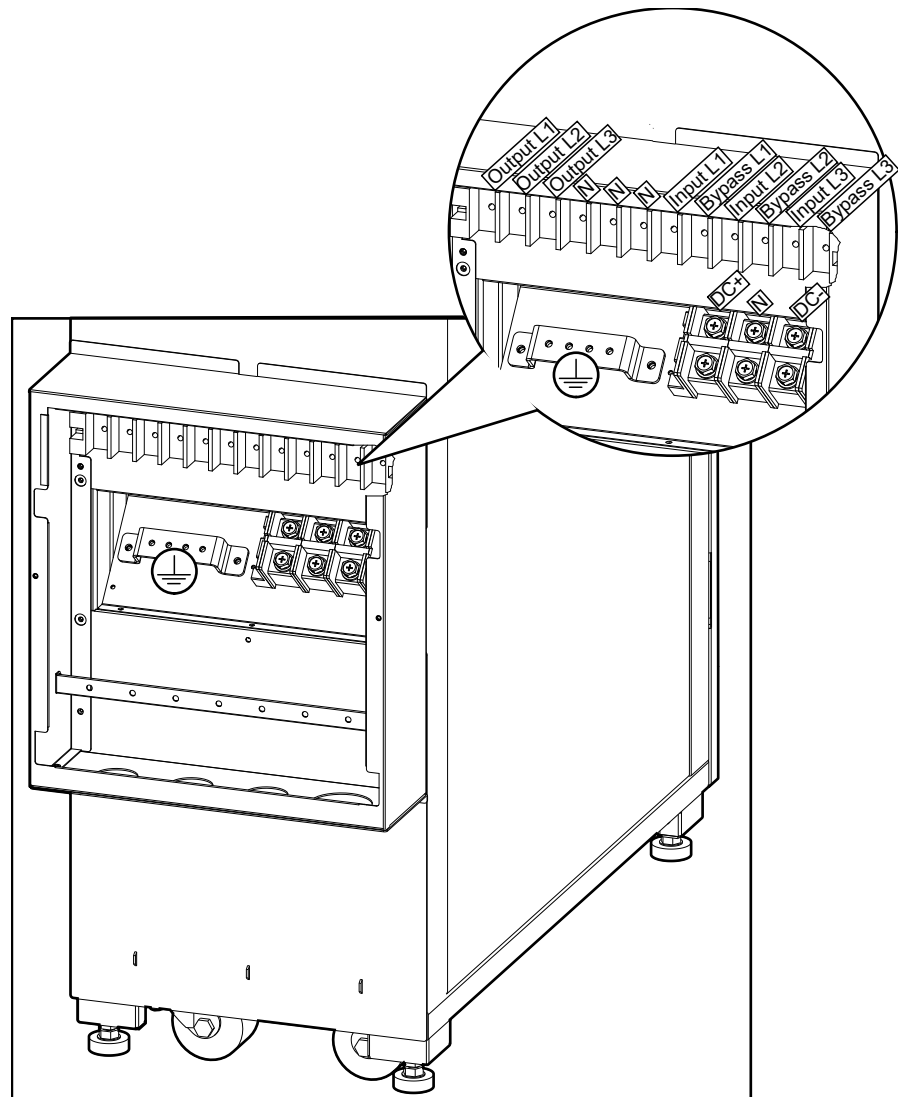

8. Connect the input cables (L1, L2, L3, N).
9. Connect the output cables (L1, L2, L3, N).
10. Connect the bypass cables (L1, L2, L3, N) (if applicable).
11. Connect the battery cables (DC+, DC-, N).
12. Reinstall the terminal covers and the conduit box cover.

Connect the Power Cables in a 30 kVA UPS

1. Ensure that all breakers are in the OFF (open) position.
2. Remove the conduit box cover.

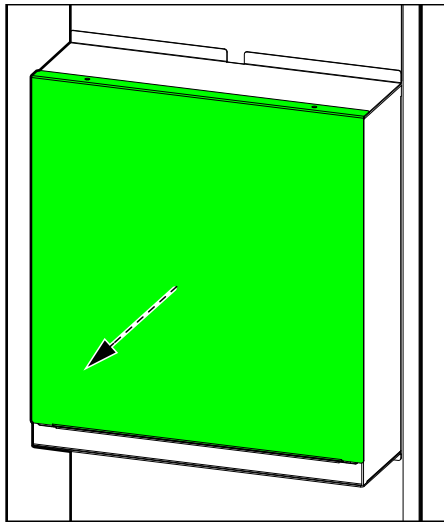

3. Remove the two terminal covers.

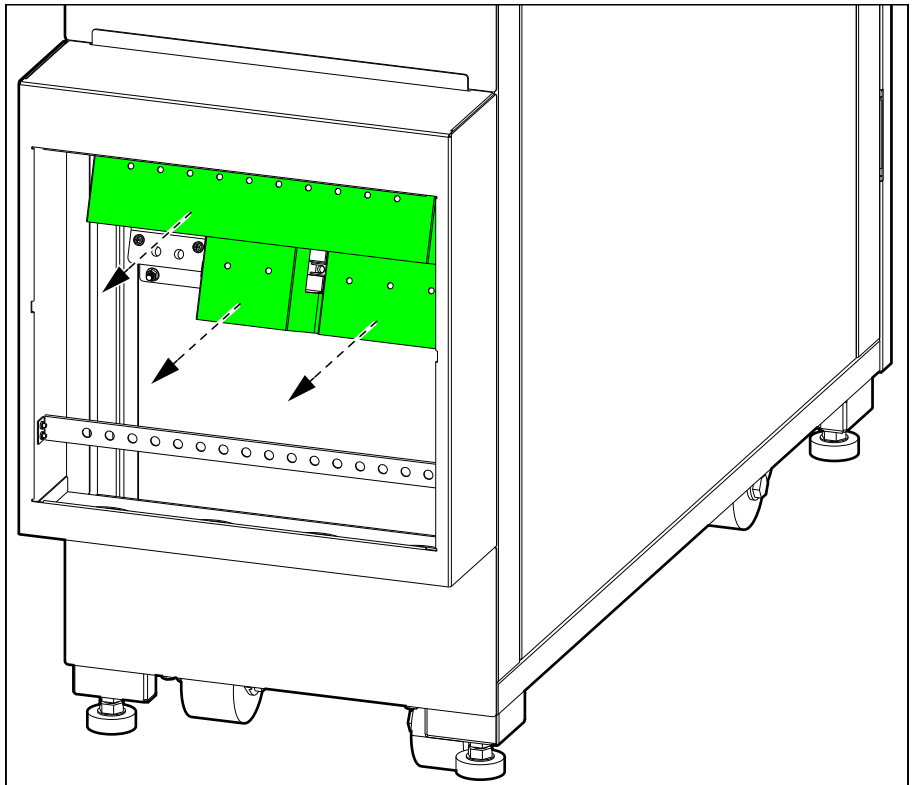

- In dual mains systems, remove the three single mains jumpers. Save the single mains jumpers for the self-aging test.

NOTE: Save these jumpers for future service visit use by Schneider Electric.

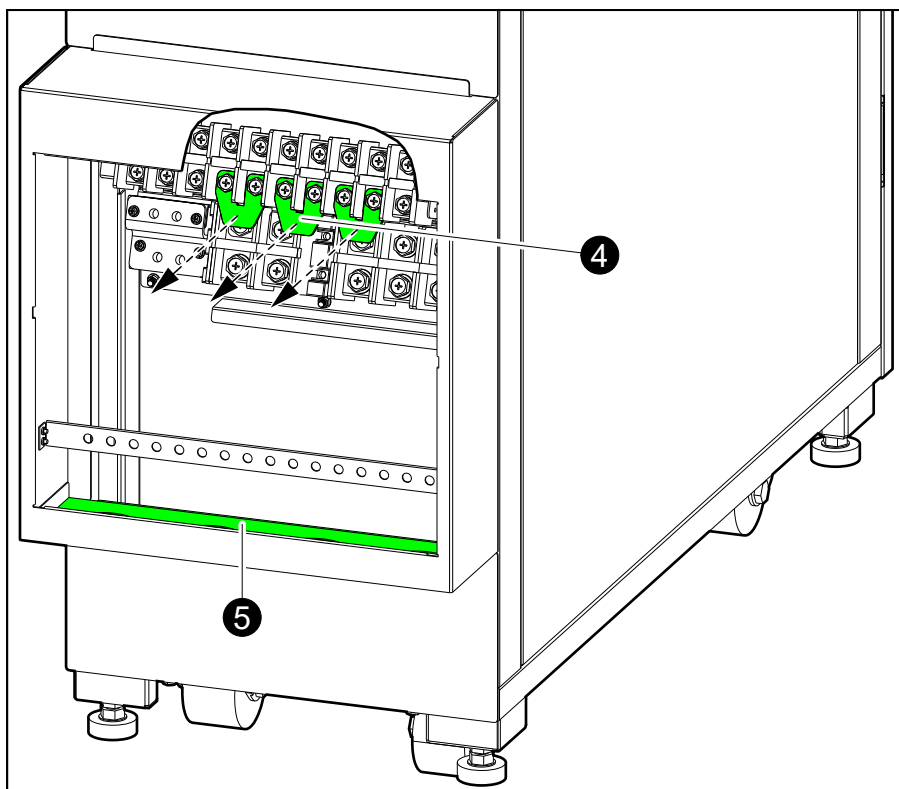

- Remove the gland plate from the bottom of the conduit box. Drill or cut holes in the gland plate for cables/conduits. Install conduits (if applicable) and reinstall the gland plate.

⚡⚠ DANGER

HAZARD OF ELECTRIC SHOCK, EXPLOSION, OR ARC FLASH

Do not drill or cut holes for cables or conduits with the gland plate installed and do not drill or cut holes in close proximity to the UPS.

Failure to follow these instructions will result in death or serious injury.

- Route the power cables through the bottom of the conduit box.

7. Connect the equipment grounding conductor.

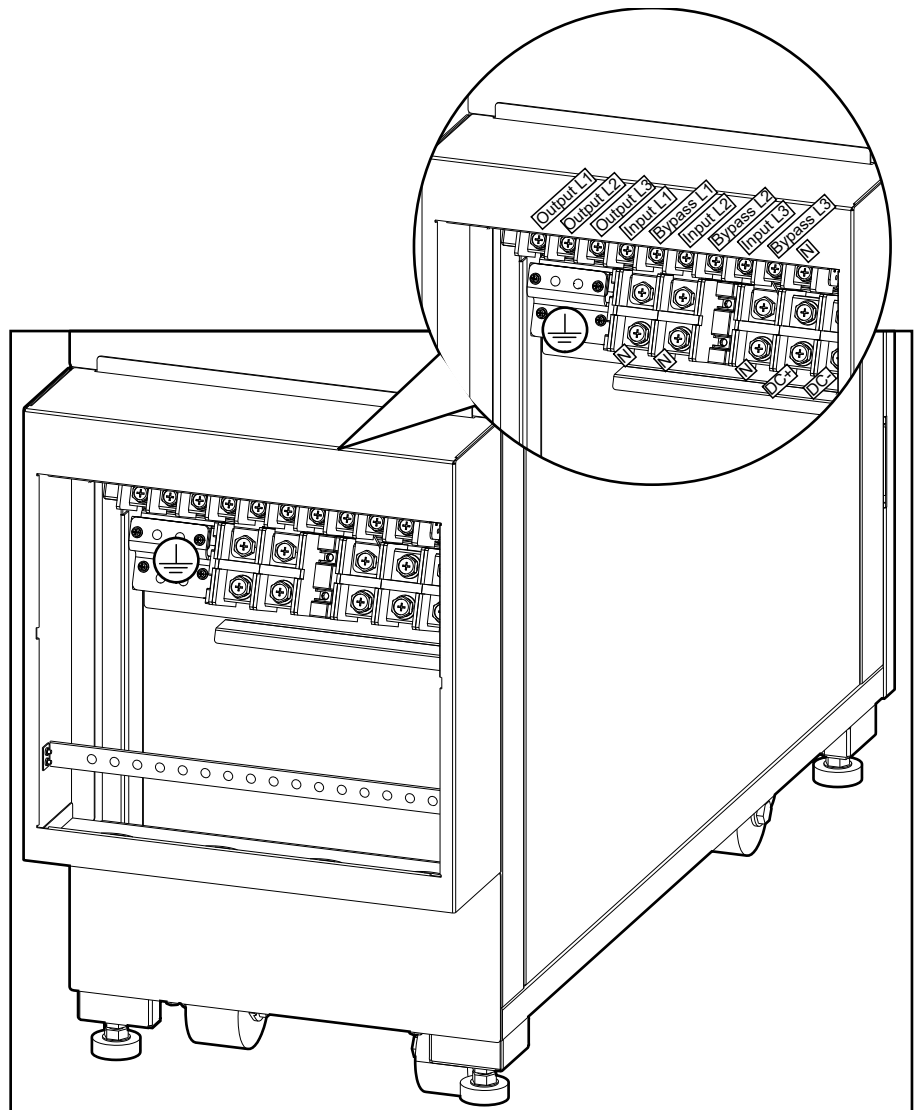

8. Connect the battery cables (DC+, DC-, N). Connect the input cables (N). Connect the bypass cables (N) (if applicable). Reinstall the cover over the N and DC-terminals.
9. Connect the input cables (L1, L2, L3).
10. Connect the output cables (L1, L2, L3, N).
11. Connect the bypass cables (L1, L2, L3) (if applicable).
12. Reinstall the terminal cover over the input, output and bypass terminals and the reinstall the conduit box cover.

Connect the Power Cables in a 40 kVA UPS

1. Ensure that all breakers are in the OFF (open) position.
2. Remove the conduit box cover.

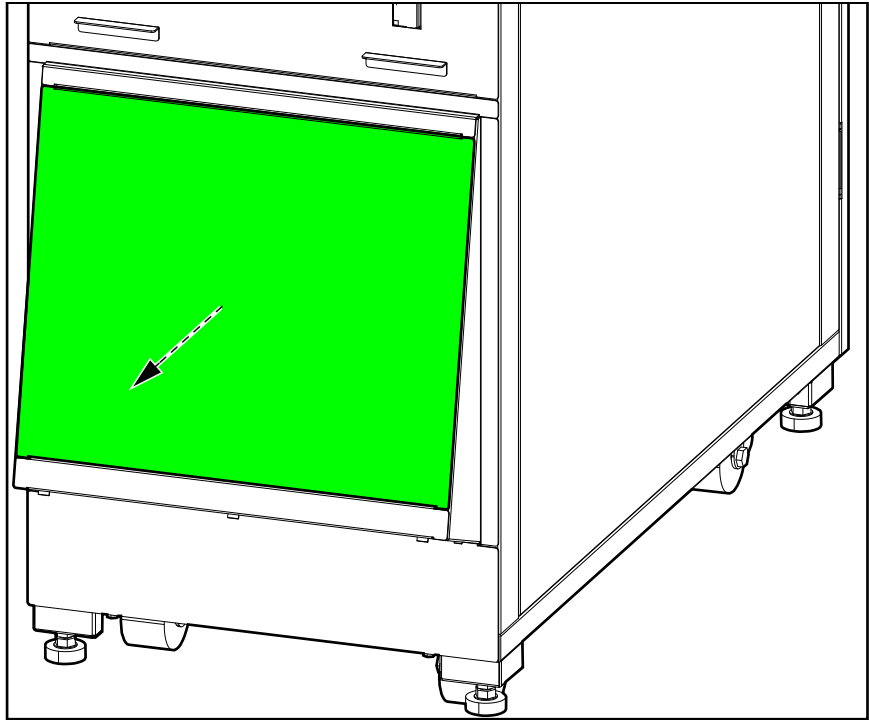

3. Remove the three terminal covers.

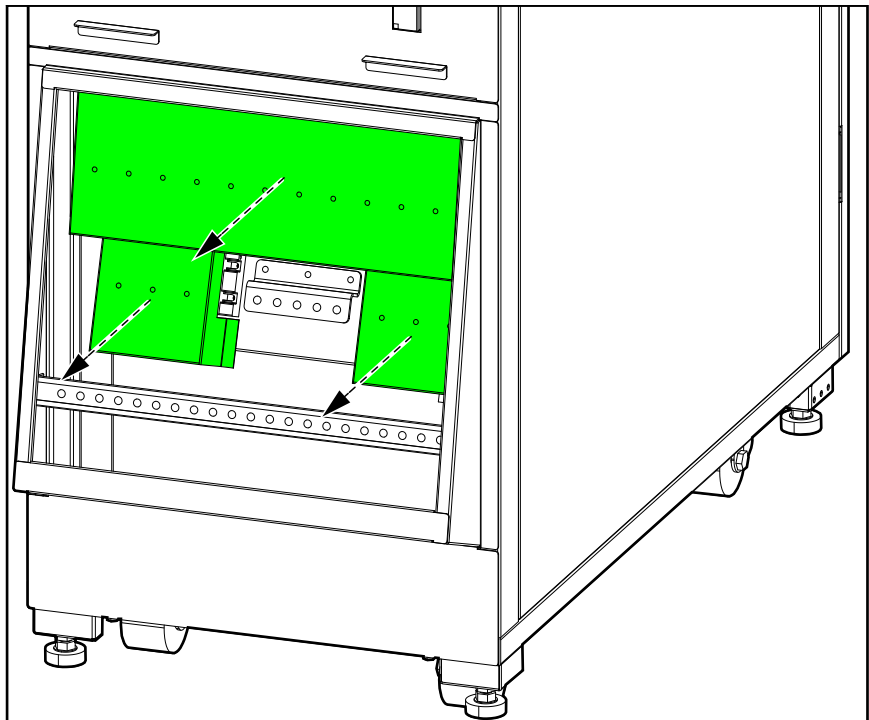

- In dual mains systems, remove the three single mains jumpers.

NOTE: Save these jumpers for future service visit use by Schneider Electric.

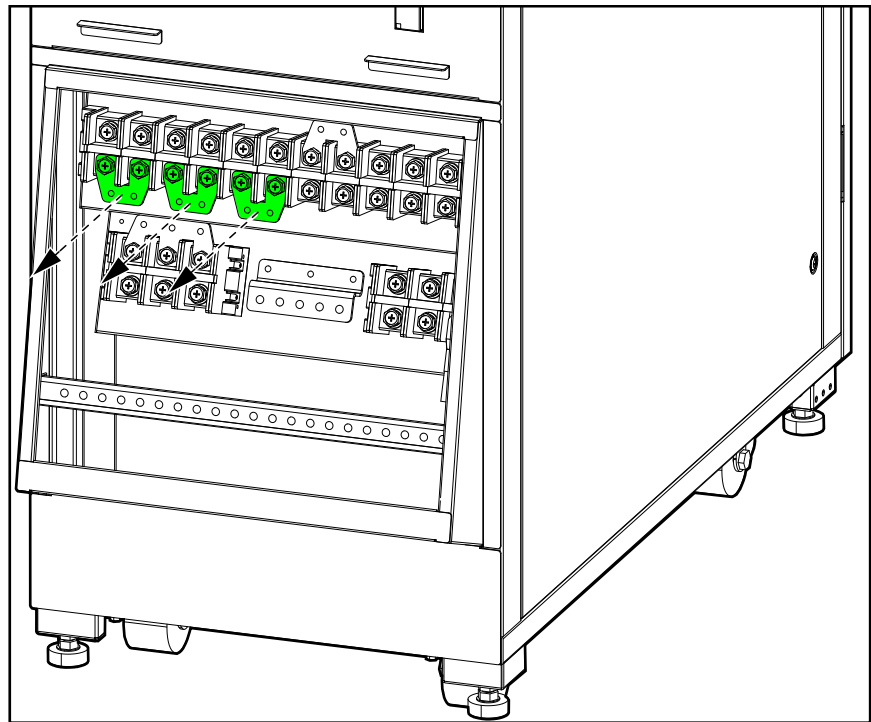

- Remove the gland plate from the bottom of the conduit box. Drill or cut holes in the gland plate for cables/conduits. Install conduits (if applicable) and reinstall the gland plate.

⚡ ⚠ DANGER

HAZARD OF ELECTRIC SHOCK, EXPLOSION, OR ARC FLASH

Do not drill or cut holes for cables or conduits with the gland plate installed and do not drill or cut holes in close proximity to the UPS.

Failure to follow these instructions will result in death or serious injury.

- Route the power cables through the bottom of the conduit box.

7. Connect the equipment grounding conductor.

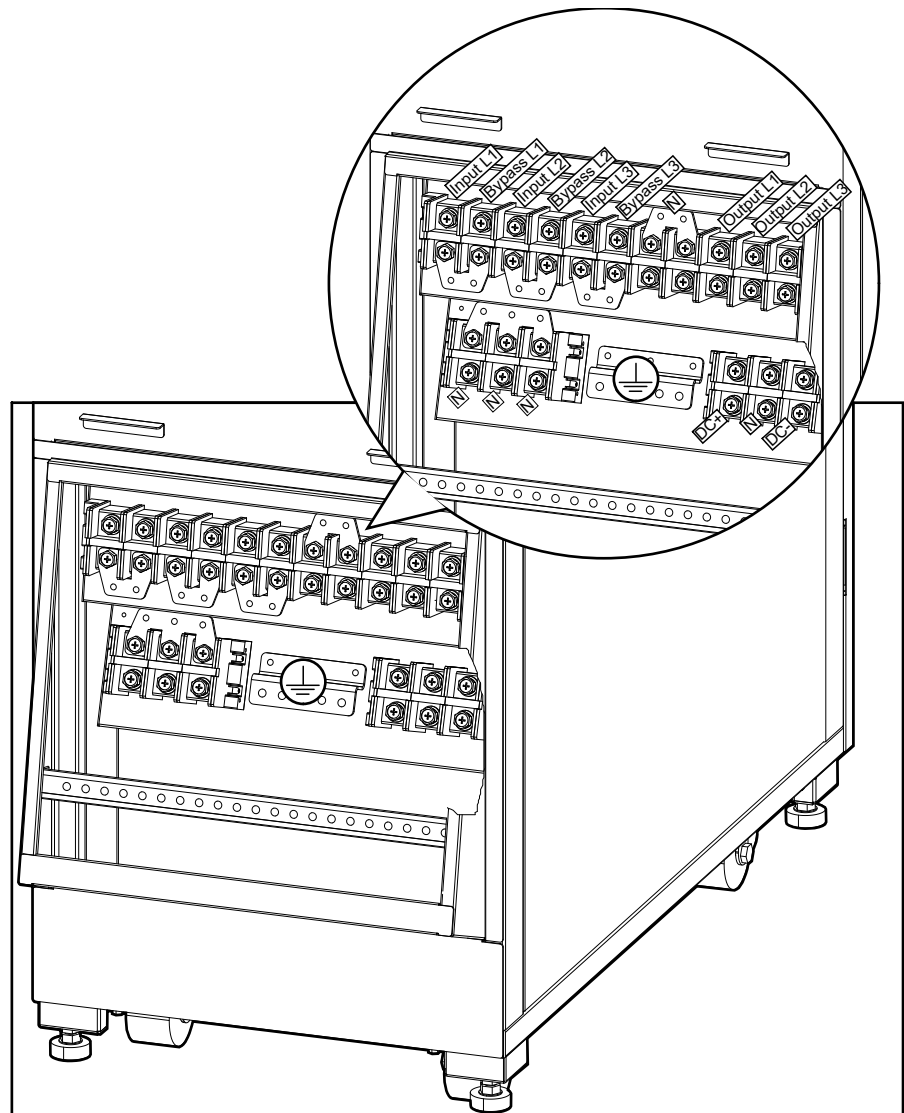

8. Connect the battery cables (DC+, DC-, N). Connect the input cables (N). Connect the bypass cables (N) (if applicable). Reinstall the cover over the N and DC-terminals.
9. Connect the input cables (L1, L2, L3).
10. Connect the output cables (L1, L2, L3, N).
11. Connect the bypass cables (L1, L2, L3) (if applicable).
12. Reinstall the terminal cover over the input, output and bypass terminals and the reinstall the conduit box cover.

Communication Interfaces

Rear View of UPS

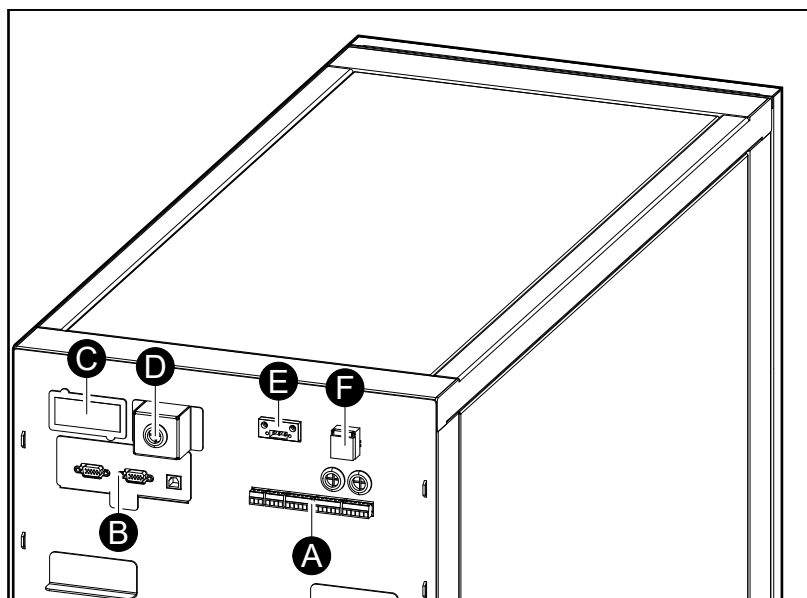

- A. Dry contacts
- B. Parallel ports
- C. Network management card (NMC)
- D. External MBB status indicator
- E. RS485
- F. Cold start (optional)

Input Contacts and Output Relays

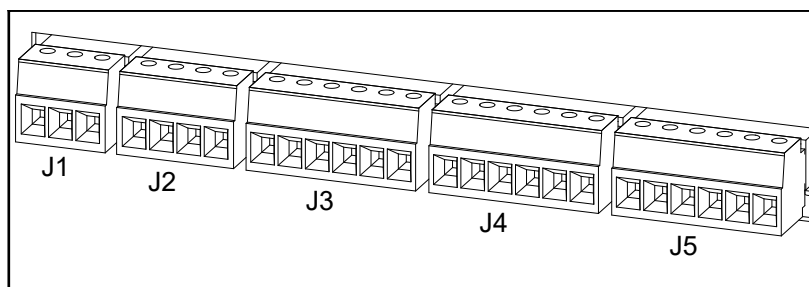

Dry Contact Interface for External Connections

Terminal	Function	Diagram
J1-1	Configurable output	
J1-2		
J1-3		

Terminal	Function		Diagram
J2-1	Configurable input	Input	
J2-2		GND	
J2-3	EPO normally closed	EPO NC	
J2-4		+24 V	
J3-1	External battery breaker trip signal	Ext_BB_trip +24 V/200 mA	
J3-2		GND	
J3-3	External battery status signal	Ext_BB_trip +24 V/200 mA	
J3-4		GND	
J3-5	External battery temperature signal	Temp 2	
J3-6	Battery temperature sensor 2 GND	Temp_COM	

Dry Contact Interface for Internal Connections

Terminal	Function		Diagram
J4-1	Internal battery temperature signal	Temp 1	
J4-2		Temp_COM	
J4-3	battery status signal	Input_1	
J4-4		+24 V	
J4-5	Backfeed trip signal	+24 V	
J4-6		GND	
J5-1	Backfeed trip signal for UIB	NC	
J5-2		NO	
J5-3		COM	
J5-4	Backfeed trip signal for SSIB	NC	
J5-5		NO	
J5-6		COM	

Connect the Signal Cables in Parallel Systems

1. Connect the optional parallel cables (E3SOPT002³) between all the UPSs of the parallel system.

NOTE: See Communication Interfaces, page 39 for location of parallel ports.

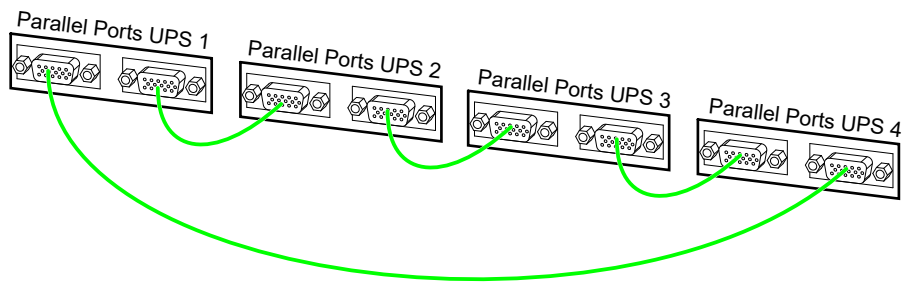

3. Each kit consists of one 5 m parallel cable.

Install Batteries in the UPS

1. Remove the plate in front of the battery shelves.

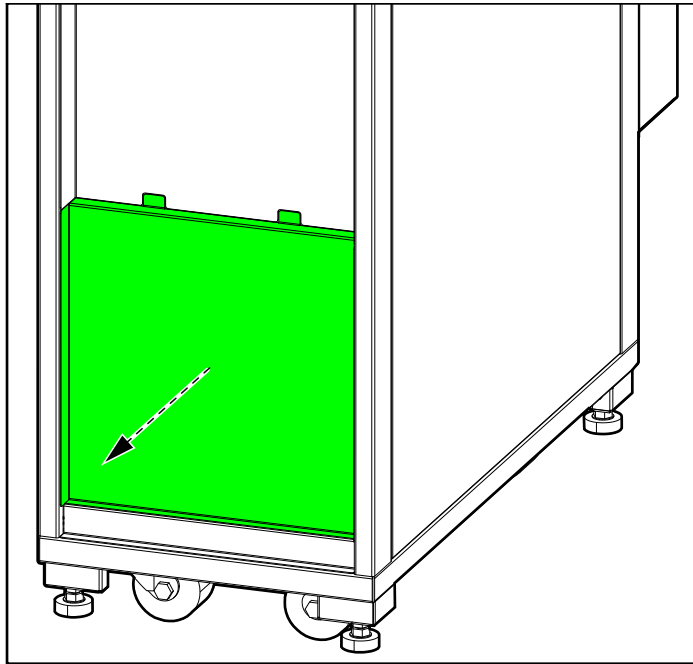

2. Cut the three cable ties that hold the battery cables to the frame.
3. Remove the screws before loading the battery modules. Save the screws for future use.

4. Holding the handle, install the battery modules one string at a time from the bottom and up.

⚠ ⚠ WARNING**HAZARD OF ARC FLASH**

Be careful not to damage the battery cables when installing the battery modules. Lift the battery cables away from the battery shelves before pushing the battery modules into the cabinet.

Failure to follow these instructions can result in death, serious injury, or equipment damage.

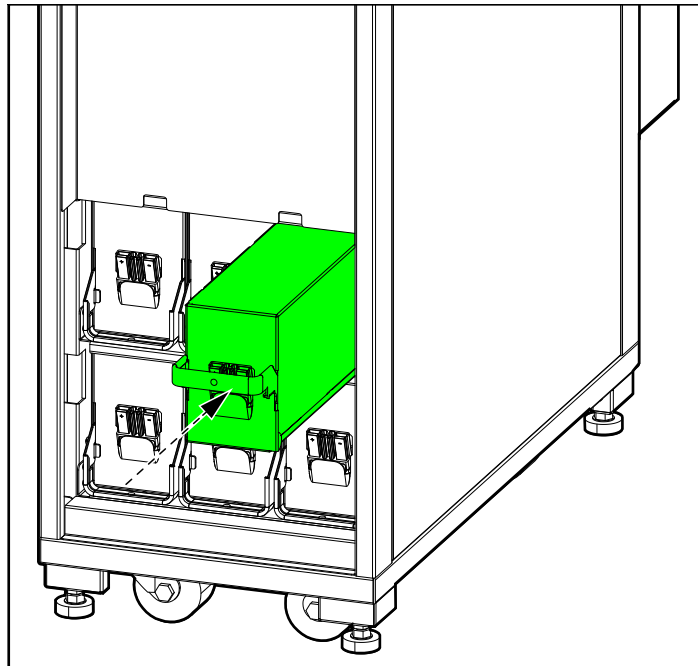

5. Push down the handle and fasten the battery module with a screw in front of the battery module.

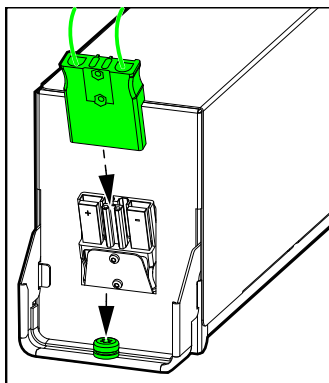

6. Remove the shrink tubes from the power terminals and connect the power terminals to the batteries.
7. Reinstall the plate in front of the battery shelves.

Schneider Electric



* 9 9 0 - 6 4 0 1 c - 0 0 1 *

As standards, specifications, and design change from time to time,
please ask for confirmation of the information given in this publication.

© 2020 – 2023 Schneider Electric. All rights reserved.

990-6401C-001