

Galaxy VX

UPS with 1250 kW I/O Cabinet

Installation

380 V, 400 V, 415 V, 440 V, and 480 V

500 kW/kVA, 500 kW/kVA N+1, 625 kW/kVA, 800 kW/kVA

500 kW/kVA Expandable to 750 kW/kVA, 750 kW/kVA, 750 kW/kVA N+1

500 kW/kVA, 625 kW/kVA, 750 kW/kVA Expandable to 1000 kW/kVA, 1000 kW/kVA, 1000 kW/kVA N+1

1100 kW/kVA, 1100 kW/kVA N+1

500 kW/kVA, 750 kW/kVA, and 1000 kW/kVA Expandable to 1250 kW/kVA, 1250 kW/kVA, 1250 kW/kVA, 1250 kW/kVA N+1

Latest updates are available on the Schneider Electric website

4/2025



Legal Information

The information provided in this document contains general descriptions, technical characteristics and/or recommendations related to products/solutions.

This document is not intended as a substitute for a detailed study or operational and site-specific development or schematic plan. It is not to be used for determining suitability or reliability of the products/solutions for specific user applications. It is the duty of any such user to perform or have any professional expert of its choice (integrator, specifier or the like) perform the appropriate and comprehensive risk analysis, evaluation and testing of the products/solutions with respect to the relevant specific application or use thereof.

The Schneider Electric brand and any trademarks of Schneider Electric SE and its subsidiaries referred to in this document are the property of Schneider Electric SE or its subsidiaries. All other brands may be trademarks of their respective owner.

This document and its content are protected under applicable copyright laws and provided for informative use only. No part of this document may be reproduced or transmitted in any form or by any means (electronic, mechanical, photocopying, recording, or otherwise), for any purpose, without the prior written permission of Schneider Electric.

Schneider Electric does not grant any right or license for commercial use of the document or its content, except for a non-exclusive and personal license to consult it on an "as is" basis.

Schneider Electric reserves the right to make changes or updates with respect to or in the content of this document or the format thereof, at any time without notice.

To the extent permitted by applicable law, no responsibility or liability is assumed by Schneider Electric and its subsidiaries for any errors or omissions in the informational content of this document, as well as any non-intended use or misuse of the content thereof.

Access to Your Product Manuals Online

Find the UPS Manuals, Submittal Drawings, and Other Documentation for Your Specific UPS Here:

In your web browser, type in <https://www.go2se.com/ref=> and the commercial reference for your product.

Example: <https://www.go2se.com/ref=GVX1250K1250NHS>

Example: <https://www.go2se.com/ref=GVX1500K1500GS>

Find the UPS Manuals, Relevant Auxiliary Product Manuals, and Option Manuals Here:

Scan the QR code to go to the Galaxy VX online manual portal:

IEC (380/400/415/440 V)



https://www.productinfo.schneider-electric.com/galaxyvx_iec/

UL (480 V)



https://www.productinfo.schneider-electric.com/galaxyvx_ul/

Here you can find your UPS installation manual, UPS operation manual, and UPS technical specifications, and you can also find installation manuals for your auxiliary products and options.

This online manual portal is available on all devices and offers digital pages, search functionality across the different documents in the portal, and PDF download for offline use.

Learn More About the Galaxy VX Here:

Go to <https://www.se.com/ww/en/product-range/63732> to learn more about this product.

Table of Contents

Important Safety Instructions — SAVE THESE	
INSTRUCTIONS	7
FCC Statement	8
Electromagnetic Compatibility	8
Safety Precautions	8
Electrical Safety	11
Battery Safety	12
Specifications	14
Overview of Configurations	14
Overview of UPSs with 1250 kW I/O Cabinet - Single Utility/ Mains	14
Overview of UPSs with 1250 kW I/O Cabinet - Dual Utility/Mains	15
Parallel System	15
Specifications for 500 kW UPS	16
Specifications for 625 kW UPS	18
Specifications for 750 kW UPS	20
Specifications for 800 kW UPS	22
Specifications for 1000 kW UPS	24
Specifications for 1100 kW UPS	26
Specifications for 1250 kW UPS	28
Recommended Upstream Protection and Cable Sizes – IEC	30
Recommended Bolt and Lug Sizes for IEC	34
Recommended Upstream Protection and Cable Sizes – UL	35
Recommended Bolt and Lug Sizes for Copper Cables	38
Recommended Bolt and Lug Sizes for Aluminium Cables	38
Inverter Short-Circuit Capabilities (Bypass not Available)	39
Torque Specifications	43
Environment	43
Compliance	44
Weights and Dimensions for UPSs with 1250 kW I/O Cabinet	45
Clearance for UPSs with 1250 kW I/O Cabinet	46
Guidance for Organizing Battery Cables	46
Overview of Supplied Installation Kits	47
Installation Kits Shipped with the I/O Cabinet	47
Installation Kit 0H-9385	47
Installation Kit 0H-9384	48
Installation Kit 0H-1789	48
Installation Kit 0H-0889	48
Installation Kits Shipped with the Power Cabinet	49
Installation Kit 0H-9102	49
Installation Procedure	51
Mechanical Installation	52
Mount the Rear Anchoring Brackets	52
Position the Cabinets	54
Connect the Power Cables	60
Prepare the I/O Cabinet for Power Cables in Top Cable Entry Systems	60

Prepare the I/O Cabinet for Power Cables in Bottom Cable Entry Systems 61

Remove the Single Mains Busbars..... 62

Connect the Power Cables in a 380/400/415/440 V System 63

Connect the Power Cables in a 480 V System 66

Connect Cables to the External Supply for Lithium-ion Battery Solution (Optional)..... 68

Mount the Front Anchoring Brackets 70

Signal Cables 71

Route the Signal Cables between the I/O Cabinet and the Power Cabinets 71

Overview of Board Locations for External Signal Cables 75

Route External Signal Cables to the Boards..... 77

Overview of Input Contacts and Output Relays..... 81

Signal Cable Connections to the Switchgear (Boards 0P6547, 0P6548, 0P6549)..... 83

Signal Cable Connections to Classic Battery Cabinets (Boards 0P6547, 0P6549, 0P6552) 84

Signal Cable Connections to Battery Breaker Cabinet (Boards 0P6547, 0P6548, 0P6549) 85

PBUS Cable Connections (Board 0P3643) 85

Modbus Connections (Board 0P6502) 86

Connect the Emergency Power Off (EPO) 88

Signal Cables for External Synchronization..... 88

Backfeed Protection 92

Final Mechanical Assembly..... 95

Final Mechanical Assembly of the I/O Cabinet 95

Final Mechanical Assembly of the Power Cabinets..... 97

Decommission or Move the UPS to a New Location 98

Important Safety Instructions — SAVE THESE INSTRUCTIONS

Read these instructions carefully and look at the equipment to become familiar with it before trying to install, operate, service or maintain it. The following safety messages may appear throughout this manual or on the equipment to warn of potential hazards or to call attention to information that clarifies or simplifies a procedure.



The addition of this symbol to a “Danger” or “Warning” safety message indicates that an electrical hazard exists which will result in personal injury if the instructions are not followed.



This is the safety alert symbol. It is used to alert you to potential personal injury hazards. Obey all safety messages with this symbol to avoid possible injury or death.

DANGER

DANGER indicates a hazardous situation which, if not avoided, **will result in death or serious injury.**

Failure to follow these instructions will result in death or serious injury.

WARNING

WARNING indicates a hazardous situation which, if not avoided, **could result in death or serious injury.**

Failure to follow these instructions can result in death, serious injury, or equipment damage.

CAUTION

CAUTION indicates a hazardous situation which, if not avoided, **could result in minor or moderate injury.**

Failure to follow these instructions can result in injury or equipment damage.

NOTICE

NOTICE is used to address practices not related to physical injury. The safety alert symbol shall not be used with this type of safety message.

Failure to follow these instructions can result in equipment damage.

Please Note

Electrical equipment should only be installed, operated, serviced, and maintained by qualified personnel. No responsibility is assumed by Schneider Electric for any consequences arising out of the use of this material.

A qualified person is one who has skills and knowledge related to the construction, installation, and operation of electrical equipment and has received safety training to recognize and avoid the hazards involved.

Per IEC 62040-1: "Uninterruptible power systems (UPS) -- Part 1: Safety Requirements," this equipment, including battery access, must be inspected, installed and maintained by a skilled person.

The skilled person is a person with relevant education and experience to enable him or her to perceive risks and to avoid hazards which the equipment can create (reference IEC 62040-1, section 3.102).

FCC Statement

NOTE: This equipment has been tested and found to comply with the limits for a Class A digital device, pursuant to Part 15 of the FCC Rules. These limits are designed to provide reasonable protection against harmful interference when the equipment is operated in a commercial environment. This equipment generates, uses, and can radiate radio frequency energy and, if not installed and used in accordance with the instruction manual, may cause harmful interference to radio communications. Operation of this equipment in a residential area is likely to cause harmful interference in which case the user will be required to correct the interference at his own expense.

Any changes or modifications not expressly approved by the party responsible for compliance could void the user's authority to operate the equipment.

Electromagnetic Compatibility

NOTICE

RISK OF ELECTROMAGNETIC DISTURBANCE

This is a product Category C3 according to IEC 62040-2. This is a product for commercial and industrial applications in the second environment - installation restrictions or additional measures may be needed to prevent disturbances. The second environment includes all commercial, light industry, and industrial locations other than residential, commercial, and light industrial premises directly connected without intermediate transformer to a public low-voltage mains supply. The installation and cabling must follow the electromagnetic compatibility rules, e.g.:

- the segregation of cables,
- the use of shielded or special cables when relevant,
- the use of grounded metallic cable tray and supports.

Failure to follow these instructions can result in equipment damage.

Safety Precautions

⚠ DANGER

HAZARD OF ELECTRIC SHOCK, EXPLOSION, OR ARC FLASH

All safety instructions in this document must be read, understood and followed.

Failure to follow these instructions will result in death or serious injury.

⚠ DANGER

HAZARD OF ELECTRIC SHOCK, EXPLOSION, OR ARC FLASH

Read all instructions in the Installation Manual before installing or working on this UPS system.

Failure to follow these instructions will result in death or serious injury.

⚠ DANGER

HAZARD OF ELECTRIC SHOCK, EXPLOSION, OR ARC FLASH

Do not install the UPS system until all construction work has been completed and the installation room has been cleaned.

Failure to follow these instructions will result in death or serious injury.

⚠ DANGER

HAZARD OF ELECTRIC SHOCK, EXPLOSION, OR ARC FLASH

- The product must be installed according to the specifications and requirements as defined by Schneider Electric. It concerns in particular the external and internal protections (upstream disconnect devices, battery disconnect devices, cabling, etc.) and environmental requirements. No responsibility is assumed by Schneider Electric if these requirements are not respected.
- After the UPS system has been electrically wired, do not start up the system. Start-up must only be performed by Schneider Electric.

Failure to follow these instructions will result in death or serious injury.

⚠ DANGER

HAZARD OF ELECTRIC SHOCK, EXPLOSION, OR ARC FLASH

The UPS system must be installed according to local and national regulations. Install the UPS according to:

- IEC 60364 (including 60364-4-41- protection against electric shock, 60364-4-42 - protection against thermal effect, and 60364-4-43 - protection against overcurrent), **or**
- NEC NFPA 70, **or**
- Canadian Electrical Code (C22.1, Part 1)

depending on which one of the standards apply in your local area.

Failure to follow these instructions will result in death or serious injury.

⚠ DANGER

HAZARD OF ELECTRIC SHOCK, EXPLOSION, OR ARC FLASH

- Install the UPS system in a temperature controlled indoor environment free of conductive contaminants and humidity.
- Install the UPS system on a non-flammable, level and solid surface (e.g. concrete) that can support the weight of the system.

Failure to follow these instructions will result in death or serious injury.

⚠ DANGER**HAZARD OF ELECTRIC SHOCK, EXPLOSION, OR ARC FLASH**

The UPS is not designed for and must therefore not be installed in the following unusual operating environments:

- Damaging fumes
- Explosive mixtures of dust or gases, corrosive gases, or conductive or radiant heat from other sources
- Moisture, abrasive dust, steam or in an excessively damp environment
- Fungus, insects, vermin
- Salt-laden air or contaminated cooling refrigerant
- Pollution degree higher than 2 according to IEC 60664-1
- Exposure to abnormal vibrations, shocks, and tilting
- Exposure to direct sunlight, heat sources, or strong electromagnetic fields

Failure to follow these instructions will result in death or serious injury.

⚠ DANGER**HAZARD OF ELECTRIC SHOCK, EXPLOSION, OR ARC FLASH**

Do not drill or cut holes for cables or conduits with the gland plates installed and do not drill or cut holes in close proximity to the UPS.

Failure to follow these instructions will result in death or serious injury.

⚠ DANGER**HAZARD OF ELECTRIC SHOCK, EXPLOSION, OR ARC FLASH**

Do not make mechanical changes to the product (including removal of cabinet parts or drilling/cutting of holes) that are not described in the Installation Manual.

Failure to follow these instructions will result in death or serious injury.

NOTICE**RISK OF OVERHEATING**

Respect the space requirements around the UPS system and do not cover the product's ventilation openings when the UPS system is in operation.

Failure to follow these instructions can result in equipment damage.

NOTICE**RISK OF EQUIPMENT DAMAGE**

Do not connect the UPS output to regenerative load systems including photovoltaic systems and speed drives.

Failure to follow these instructions can result in equipment damage.

Electrical Safety

This manual contains important safety instructions that should be followed during the installation and maintenance of the UPS system.

⚠️⚠️ DANGER

HAZARD OF ELECTRIC SHOCK, EXPLOSION, OR ARC FLASH

- Electrical equipment must be installed, operated, serviced, and maintained only by qualified personnel.
- Apply appropriate personal protective equipment (PPE) and follow safe electrical work practices.
- Disconnection devices for AC and DC must be provided by others, be readily accessible, and the function of the disconnect device marked for its function.
- Turn off all power supplying the UPS system before working on or inside the equipment.
- Before working on the UPS system, check for hazardous voltage between all terminals including the protective earth.
- The UPS contains an internal energy source. Hazardous voltage can be present even when disconnected from the mains supply. Before installing or servicing the UPS system, ensure that the units are OFF and that mains and batteries are disconnected. Wait five minutes before opening the UPS to allow the capacitors to discharge.
- The UPS must be properly earthed/grounded and due to a high touch current/leakage current, the earthing/grounding conductor must be connected first.

Failure to follow these instructions will result in death or serious injury.

The label below must be added if:

1. The UPS input is connected through external isolators that, when opened, isolate the neutral, OR
2. The UPS input is connected via an IT power system.

The label must be placed adjacent to all upstream power disconnection devices that isolate the neutral.

The label below must be also added if backfeed protection is provided external to the equipment. See *Backfeed Protection*, page 92 for more details. The label must be placed adjacent to all upstream power disconnection devices.

⚠️⚠️ DANGER

HAZARD OF ELECTRIC SHOCK, EXPLOSION, OR ARC FLASH

Risk of voltage backfeed. Before working on this circuit: Isolate the UPS and check for hazardous voltage between all terminals including the protective earth.

Failure to follow these instructions will result in death or serious injury.

⚠️ DANGER

HAZARD OF ELECTRIC SHOCK, EXPLOSION, OR ARC FLASH

- Always perform correct Lockout/Tagout before working on the UPS.
- A UPS with autostart enabled will automatically restart when the mains supply returns.
- If autostart is enabled on the UPS, a label must be added on the UPS to warn about this functionality.

Failure to follow these instructions will result in death or serious injury.

Add the label below on the UPS if autostart has been enabled:

DANGER

HAZARD OF ELECTRIC SHOCK, EXPLOSION, OR ARC FLASH

Autostart is enabled. The UPS will automatically restart when the mains supply returns.

Failure to follow these instructions will result in death or serious injury.

NOTICE

RISK OF UNINTENTIONAL DEVICE OPERATION

If a residual current-operated protective device (RCD-B) is used upstream as ground fault protection, then the RCD-B shall be sized to not trip on the leakage current of this product. The start-up leakage current can be up to 3 A. The continuous maximum leakage current is 350 mA.

Failure to follow these instructions can result in equipment damage.

Battery Safety

DANGER

HAZARD OF ELECTRIC SHOCK, EXPLOSION, OR ARC FLASH

- Battery disconnect devices must be installed according to the specifications and requirements as defined by Schneider Electric.
- Servicing of batteries must only be performed or supervised by qualified personnel knowledgeable of batteries and the required precautions. Keep unqualified personnel away from batteries.
- Disconnect charging source prior to connecting or disconnecting battery terminals.
- Do not dispose of batteries in a fire as they can explode.
- Do not open, alter, or mutilate batteries. Released electrolyte is harmful to the skin and eyes. It may be toxic.

Failure to follow these instructions will result in death or serious injury.

DANGER

HAZARD OF ELECTRIC SHOCK, EXPLOSION, OR ARC FLASH

Batteries can present a risk of electric shock and high short-circuit current. The following precautions must be observed when working on batteries

- Remove watches, rings, or other metal objects.
- Use tools with insulated handles.
- Wear protective glasses, gloves and boots.
- Do not lay tools or metal parts on top of batteries.
- Disconnect the charging source prior to connecting or disconnecting battery terminals.
- Determine if the battery is inadvertently grounded. If inadvertently grounded, remove source from ground. Contact with any part of a grounded battery can result in electric shock. The likelihood of such shock can be reduced if such grounds are removed during installation and maintenance (applicable to equipment and remote battery supplies not having a grounded supply circuit).

Failure to follow these instructions will result in death or serious injury.

⚠️⚠️ DANGER

HAZARD OF ELECTRIC SHOCK, EXPLOSION, OR ARC FLASH

When replacing batteries, always replace with the same type and number of batteries or battery packs.

Failure to follow these instructions will result in death or serious injury.

⚠️ CAUTION

RISK OF EQUIPMENT DAMAGE

- Mount the batteries in the UPS system, but do not connect the batteries until the UPS system is ready to be powered up. The time duration from battery connection until the UPS system is powered up must not exceed 72 hours or 3 days.
- Batteries must not be stored more than six months due to the requirement of recharging. If the UPS system remains de-energized for a long period, we recommend that you energize the UPS system for a period of 24 hours at least once every month. This charges the batteries, thus avoiding irreversible damage.

Failure to follow these instructions can result in injury or equipment damage.

Specifications

Overview of Configurations

Breakers in the System

UIB	Unit input breaker
SSIB	Static switch input breaker
BB	Battery breaker
MBB	Maintenance bypass breaker
UOB	Unit output breaker
BF2	Backfeed protection switch

Overview of UPSs with 1250 kW I/O Cabinet - Single Utility/Mains

NOTE: Depending on your chosen configuration, the backfeed breaker BF2 (marked with * in the illustration) can be preinstalled in the UPS, delivered as an optional backfeed kit GVXOPT001 to be installed in the UPS, or installed upstream of the UPS in the switchgear.

The illustration shows a 750 kW UPS. The principle is the same for the other UPSs with the 1250 kW I/O cabinet.

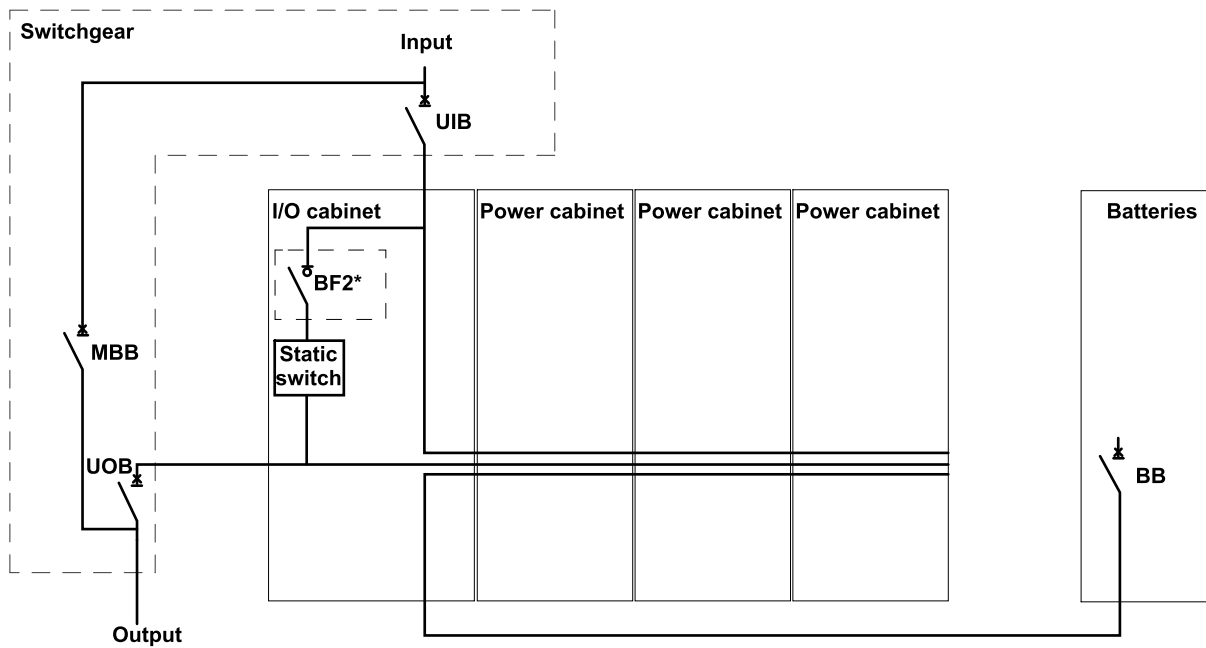

Overview of UPSs with 1250 kW I/O Cabinet - Dual Utility/Mains

NOTE: Depending on your chosen configuration, the backfeed breaker BF2 (marked with * in the illustration) can be preinstalled in the UPS, delivered as an optional backfeed kit GVXOPT001 to be installed in the UPS, or installed upstream of the UPS in the switchgear.

The illustration shows a 750 kW UPS. The principle is the same for the other UPSs with the 1250 kW I/O cabinet.

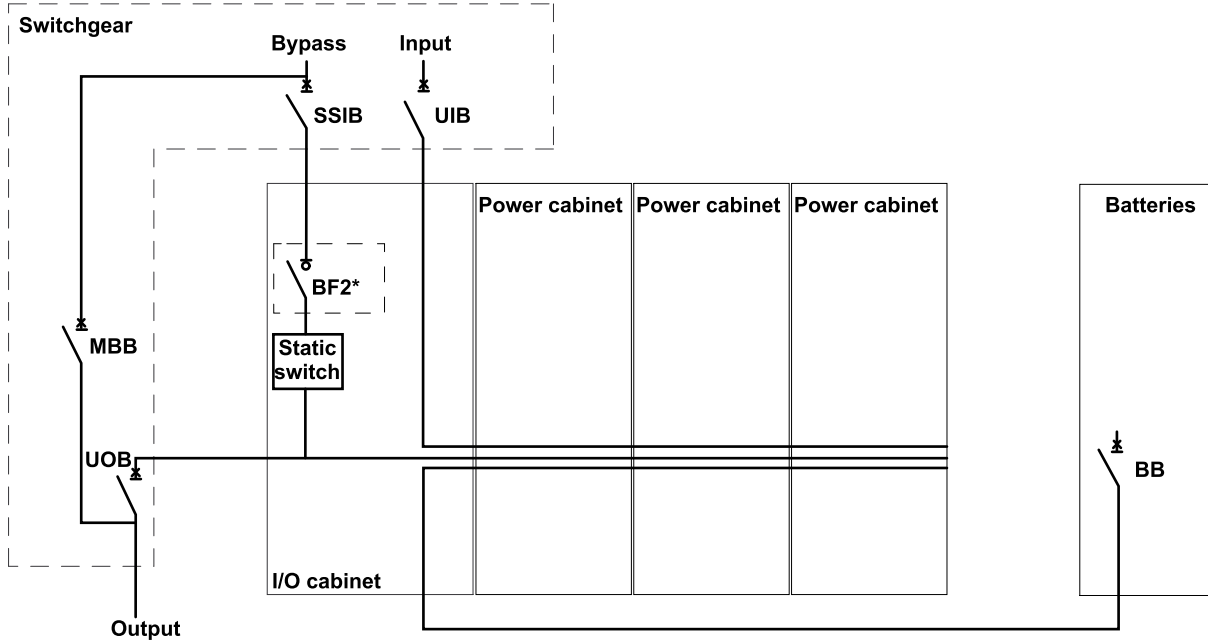

Parallel System

Galaxy VX can support up to 4+0 UPSs in parallel for capacity and up to 4+1 UPSs in parallel for redundancy.

NOTE: Note that for systems over 4 MW it can be difficult to find appropriate breakers/switches in the correct size for the switchgear.

Specifications for 500 kW UPS

	Voltage (V)	380	400	415	440	480
Input	Connections	IEC: L1, L2, L3, PE ¹ UL: L1, L2, L3 + G ²				
	Input voltage range (V) ³	340-456	340-480	353-498	374-528	408-576
	Frequency (Hz)	40-70				
	Nominal input current (A)	816	775	746	699	646
	Maximum input current (A) ⁴	921	885	852	798	757
	Input current limitation (A)	890			832	760
	Minimum short circuit rating	Dependent on upstream protection. See section for 'Recommended upstream protection and cable sizes – IEC' for details.				
	Maximum short circuit rating	100 kA RMS				
	Total harmonic distortion (THDI)	<3% at 100% load, <4% at 50% load, <9% at 25% load				
	Input power factor	0.99 at >40% load, 0.98 at >20% load, 0.97 at >10% load				
	Protection	Contactors				
	Ramp-in	Adaptive 1-300 seconds				
Bypass	Connections	IEC 1250 kW I/O and 1500 kW I/O: L1, L2, L3, N, PE or L1, L2, L3, PE ⁵ UL 1250 kW I/O: L1, L2, L3, G or L1, L2, L3, N, G UL 1500 kW I/O ⁶ : L1, L2, L3, G				
	Bypass voltage range (V)	342-418	360-440	374-457	396-484	432-528
	Frequency (Hz)	50 or 60				
	Frequency range (Hz)	Programmable: ±0.1, ±3, ±10. Default is ±3				
	Nominal bypass current (A)	813	773	745	703	642
	Minimum short circuit rating	Dependent on upstream protection. See section for 'Recommended upstream protection and cable sizes – IEC' for details.				
	Maximum short circuit rating	1250 kW I/O: 100 kA I _{cw} 1500 kW I/O: 100 kA RMS (conditioned by an internal molded switch with 90 kA peak magnetic trip)				
	Thyristor I ² t (kA*s ²)	1250 kW I/O: 9680 1500 kW I/O: 16245			1250 kW I/O: 9165 1500 kW I/O: 16245	
	BF2 magnetic trip	1250 kW I/O: 39 kA 1500 kW I/O: 39 kA				
	Protection	1250 kW I/O with preinstalled backfeed breaker BF2: Molded switch with trip for backfeed protection 1250 kW I/O with GVXOPT001 installed: Molded switch with trip for backfeed protection 1500 kW I/O with preinstalled backfeed breaker BF2: Molded switch with trip for backfeed protection				

1. TN, TT, and IT power distribution systems are supported.
2. WYE source – solid grounded and high resistance grounded sources are supported. Corner (line) grounding is not permitted.
3. The system can operate at 600 V for 1 minute.
4. At nominal input voltage and full charge.
5. TN, TT, and IT power distribution systems with no earthed line conductors are supported.
6. 4-wire connection with neutral is not compliant per FCC regulations for the 1500 kW I/O cabinet.

	Voltage (V)	380	400	415	440	480
Output	Connections	IEC 1250 kW I/O and 1500 kW I/O: L1, L2, L3, N, PE or L1, L2, L3, PE UL 1250 kw I/O: L1, L2, L3, G, GEC ⁷ or L1, L2, L3, N, G UL 1500 kW I/O ⁸ : L1, L2, L3, G, GEC ⁷				
	Overload capacity	Normal operation: 150% for 1 minute, 125% for 10 minutes Battery operation: 128% for 10 seconds, 115% for 1 minute Bypass operation: 110% ⁹ continuous, 1000% for 60 milliseconds for systems with 1250 kW I/O cabinet, and 1000% for 100 milliseconds for systems with 1500 kW I/O cabinet				
	Output voltage tolerance	Balanced load: ±1%, Unbalanced load: ±3%				
	Dynamic load response	±5% after 2 ms, ±1% after 50 ms				
	Output power factor	1				
	Nominal output current (A)	760	722	696	656	601
	Minimum short circuit rating ¹⁰	Dependent on upstream protection. See section for ' Recommended upstream protection and cable sizes – IEC ' for details.				
	Maximum short circuit rating ¹¹	100 kA RMS				
	Inverter output short circuit capabilities	Varies with time. See graph and table values in Inverter Short-Circuit Capabilities (Bypass not Available), page 39.				
	Total harmonic distortion (THDU)	<2% at 100% linear load, <3% at 100% non-linear load				
	Output frequency (Hz)	50/60 (synchronized to bypass), 50/60 Hz ±0.1% (free-running)				
	Slew rate (Hz/sec)	Programmable: 0.25, 0.5, 1, 2, 4, 6				
	Output performance classification (according to IEC/ EN62040-3)	Double-conversion: VFI-SS-111				
	Load crest factor	Up to 3 (THDU < 5%)				
	Load power factor	0.7 leading to 0.5 lagging without derating				
Battery (VRLA)	Charging power in % of output power	35% at ≤ 80% load, 12% at 100% load				40% at ≤ 80% load, 15% at 100% load
	Maximum charging power (kW)	60 at 100% load, 175 at <80% load				75 at 100% load, 200 at 80% load
	Nominal battery voltage (VDC)	480				
	Nominal float voltage (VDC)	546				
	End of discharge voltage (full load) (VDC)	384				
	End of discharge voltage (no load) (VDC)	420				
	Battery current at full load and nominal battery voltage (A)	1090				
	Battery current at full load and minimum battery voltage (A)	1362				
	Maximum short circuit rating	50 kA				
	Maximum battery backup time	Unlimited				
	Temperature compensation (per cell)	-3.3 mV per °C for T ≥ 25 °C, 0 mV per °C for T < 25 °C				
	Ripple current	< 5% C20 (5-minute backup time)				
	Battery test	Manual/automatic (selectable)				
	Deep discharge protection	Yes				
Recharge according to battery temperature	Yes					

7. Per NEC 250.30.

8. 4-wire connection with neutral is not compliant per FCC regulations for the 1500 kW I/O cabinet.

9. 125% for 480 V.

10. Minimum short circuit rating for output takes backfeeding energy through the bypass of parallel UPSs into consideration.

11. Maximum short circuit rating for output takes backfeeding energy through the bypass of parallel UPSs into consideration.

Specifications for 625 kW UPS

	Voltage (V)	380	400	415	440	480
Input	Connections	IEC: L1, L2, L3, PE ¹² UL: L1, L2, L3 + G ¹³				
	Input voltage range (V) ¹⁴	340-456	340-480	353-498	374-528	408-576
	Frequency (Hz)	40-70				
	Nominal input current (A)	1021	969	932	870	807
	Maximum input current (A) ¹⁵	1151	1106	1065	994	946
	Input current limitation (A)	1113			1040	950
	Minimum short circuit rating	Dependent on upstream protection. See section for ' Recommended upstream protection and cable sizes – IEC ' for details.				
	Maximum short circuit rating	100 kA RMS				
	Total harmonic distortion (THDI)	<3% at 100% load, <4% at 50% load, <9% at 25% load				
	Input power factor	0.99 at >40% load, 0.98 at >20% load, 0.97 at >10% load				
	Protection	Contactors				
	Ramp-in	Adaptive 1-300 seconds				
Bypass	Connections	IEC 1250 kW I/O and 1500 kW I/O: L1, L2, L3, N, PE or L1, L2, L3, PE ¹⁶ UL 1250 kW I/O: L1, L2, L3, G or L1, L2, L3, N, G UL 1500 kW I/O ¹⁷ : L1, L2, L3, G				
	Bypass voltage range (V)	342-418	360-440	374-457	396-484	432-528
	Frequency (Hz)	50 or 60				
	Frequency range (Hz)	Programmable: ±0.1, ±3, ±10. Default is ±3				
	Nominal bypass current (A)	1017	966	931	878	802
	Minimum short circuit rating	Dependent on upstream protection. See section for ' Recommended upstream protection and cable sizes – IEC ' for details.				
	Maximum short circuit rating	1250 kW I/O: 100 kA Icw 1500 kW I/O: 100 kA RMS (conditioned by an internal molded switch with 90 kA peak magnetic trip)				
	Thyristor I ² t (kA*s ²)	9680 (1250 kW I/O)				9165 (1250 kW I/O)
	BF2 magnetic trip	1250 kW I/O: 39 kA 1500 kW I/O: 39 kA				
	Protection	1250 kW I/O with preinstalled backfeed breaker BF2: Molded switch with trip for backfeed protection 1250 kW I/O with GVXOPT001 installed: Molded switch with trip for backfeed protection 1500 kW I/O with preinstalled backfeed breaker BF2: Molded switch with trip for backfeed protection				

12. TN, TT, and IT power distribution systems are supported.
 13. WYE source – solid grounded and high resistance grounded sources are supported. Corner (line) grounding is not permitted.
 14. The system can operate at 600 V for 1 minute.
 15. At nominal input voltage and full charge.
 16. TN, TT, and IT power distribution systems with no earthed line conductors are supported.
 17. 4-wire connection with neutral is not compliant per FCC regulations for the 1500 kW I/O cabinet.

	Voltage (V)	380	400	415	440	480
Output	Connections	IEC 1250 kW I/O and 1500 kW I/O: L1, L2, L3, N, PE or L1, L2, L3, PE UL 1250 kw I/O: L1, L2, L3, G, GEC ¹⁸ or L1, L2, L3, N, G UL 1500 kW I/O ¹⁹ : L1, L2, L3, G, GEC ¹⁸				
	Overload capacity	Normal operation: 150% for 1 minute, 125% for 10 minutes Battery operation: 128% for 10 seconds, 115% for 1 minute Bypass operation: 110% ²⁰ continuous, 1000% for 60 milliseconds for systems with 1250 kW I/O cabinet, and 1000% for 100 milliseconds for systems with 1500 kW I/O cabinet				
	Output voltage tolerance	Balanced load: ±1%, Unbalanced load: ±3%				
	Dynamic load response	±5% after 2 ms, ±1% after 50 ms				
	Output power factor	1				
	Nominal output current (A)	950	902	870	820	752
	Minimum short circuit rating ²¹	Dependent on upstream protection. See section for ' Recommended upstream protection and cable sizes – IEC ' for details.				
	Maximum short circuit rating ²²	100 kA RMS				
	Inverter output short circuit capabilities	Varies with time. See graph and table values in Inverter Short-Circuit Capabilities (Bypass not Available), page 39.				
	Total harmonic distortion (THDU)	<2% at 100% linear load, <3% at 100% non-linear load				
	Output frequency (Hz)	50/60 (synchronized to bypass), 50/60 Hz ±0.1% (free-running)				
	Slew rate (Hz/sec)	Programmable: 0.25, 0.5, 1, 2, 4, 6				
	Output performance classification (according to IEC/ EN62040-3)	Double-conversion: VFI-SS-111				
	Load crest factor	Up to 3 (THDU < 5%)				
	Load power factor	0.7 leading to 0.5 lagging without derating				
Battery (VRLA)	Charging power in % of output power	35% at ≤ 80% load, 12% at 100% load				40% at ≤ 80% load, 15% at 100% load
	Maximum charging power (kW)	75 at 100% load, 218.75 at <80% load				93.75 at 100% load, 250 at 80% load
	Nominal battery voltage (VDC)	480				
	Nominal float voltage (VDC)	546				
	End of discharge voltage (full load) (VDC)	384				
	End of discharge voltage (no load) (VDC)	420				
	Battery current at full load and nominal battery voltage (A)	1362				
	Battery current at full load and minimum battery voltage (A)	1703				
	Maximum short circuit rating	50 kA				
	Maximum battery backup time	Unlimited				
	Temperature compensation (per cell)	-3.3 mV per °C for T ≥ 25 °C, 0 mV per °C for T < 25 °C				
	Ripple current	< 5% C20 (5-minute backup time)				
	Battery test	Manual/automatic (selectable)				
	Deep discharge protection	Yes				
Recharge according to battery temperature	Yes					

18. Per NEC 250.30.

19. 4-wire connection with neutral is not compliant per FCC regulations for the 1500 kW I/O cabinet.

20. 125% for 480 V.

21. Minimum short circuit rating for output takes backfeeding energy through the bypass of parallel UPSs into consideration.

22. Maximum short circuit rating for output takes backfeeding energy through the bypass of parallel UPSs into consideration.

Specifications for 750 kW UPS

	Voltage (V)	380	400	415	440	480
Input	Connections	IEC: L1, L2, L3, PE ²³ UL: L1, L2, L3 + G ²⁴				
	Input voltage range (V) ²⁵	340-456	340-480	353-498	374-528	408-576
	Frequency (Hz)	40-70				
	Nominal input current (A)	1225	1162	1119	1050	969
	Maximum input current (A) ²⁶	1381	1327	1278	1199	1136
	Input current limitation (A)	1335			1248	1140
	Minimum short circuit rating	Dependent on upstream protection. See section for ' Recommended upstream protection and cable sizes – IEC ' for details.				
	Maximum short circuit rating	100 kA RMS				
	Total harmonic distortion (THDI)	<3% at 100% load, <4% at 50% load, <9% at 25% load				
	Input power factor	0.99 at >40% load, 0.98 at >20% load, 0.97 at >10% load				
	Protection	Contactors				
	Ramp-in	Adaptive 1-300 seconds				
Bypass	Connections	IEC 1250 kW I/O and 1500 kW I/O: L1, L2, L3, N, PE or L1, L2, L3, PE ²⁷ UL 1250 kW I/O: L1, L2, L3, G or L1, L2, L3, N, G UL 1500 kW I/O ²⁸ : L1, L2, L3, G				
	Bypass voltage range (V)	342-418	360-440	374-457	396-484	432-528
	Frequency (Hz)	50 or 60				
	Frequency range (Hz)	Programmable: ±0.1, ±3, ±10. Default is ±3				
	Nominal bypass current (A)	1220	1159	1117	1054	964
	Minimum short circuit rating	Dependent on upstream protection. See section for ' Recommended upstream protection and cable sizes – IEC ' for details.				
	Maximum short circuit rating	1250 kW I/O: 100 kA I _{cw} 1500 kW I/O: 100 kA RMS (conditioned by an internal molded switch with 90 kA peak magnetic trip)				
	Thyristor I ² t (kA*s ²)	1250 kW I/O: 9680 1500 kW I/O: 16245			1250 kW I/O: 9165 1500 kW I/O: 16245	
	BF2 magnetic trip	1250 kW I/O: 39 kA 1500 kW I/O: 39 kA				
	Protection	1250 kW I/O with preinstalled backfeed breaker BF2: Molded switch with trip for backfeed protection 1250 kW I/O with GVXOPT001 installed: Molded switch with trip for backfeed protection 1500 kW I/O with preinstalled backfeed breaker BF2: Molded switch with trip for backfeed protection				

23. TN, TT, and IT power distribution systems are supported.

24. WYE source – solid grounded and high resistance grounded sources are supported. Corner (line) grounding is not permitted.

25. The system can operate at 600 V for 1 minute.

26. At nominal input voltage and full charge.

27. TN, TT, and IT power distribution systems with no earthed line conductors are supported.

28. 4-wire connection with neutral is not compliant per FCC regulations for the 1500 kW I/O cabinet.

	Voltage (V)	380	400	415	440	480
Output	Connections	IEC 1250 kW I/O and 1500 kW I/O: L1, L2, L3, N, PE or L1, L2, L3, PE UL 1250 kw I/O: L1, L2, L3, G, GEC ²⁹ or L1, L2, L3, N, G UL 1500 kW I/O ³⁰ : L1, L2, L3, G, GEC ²⁹				
	Overload capacity	Normal operation: 150% for 1 minute, 125% for 10 minutes Battery operation: 128% for 10 seconds, 115% for 1 minute Bypass operation: 110% ³¹ continuous, 1000% for 60 milliseconds for systems with 1250 kW I/O cabinet, and 1000% for 100 milliseconds for systems with 1500 kW I/O cabinet				
	Output voltage tolerance	Balanced load: ±1%, Unbalanced load: ±3%				
	Dynamic load response	±5% after 2 ms, ±1% after 50 ms				
	Output power factor	1				
	Nominal output current (A)	1140	1083	1043	984	902
	Minimum short circuit rating ³²	Dependent on upstream protection. See section for ' Recommended upstream protection and cable sizes – IEC ' for details.				
	Maximum short circuit rating ³³	100 kA RMS				
	Inverter output short circuit capabilities	Varies with time. See graph and table values in Inverter Short-Circuit Capabilities (Bypass not Available), page 39.				
	Total harmonic distortion (THDU)	<2% at 100% linear load, <3% at 100% non-linear load				
	Output frequency (Hz)	50/60 (synchronized to bypass), 50/60 Hz ±0.1% (free-running)				
	Slew rate (Hz/sec)	Programmable: 0.25, 0.5, 1, 2, 4, 6				
	Output performance classification (according to IEC/ EN62040-3)	Double-conversion: VFI-SS-111				
	Load crest factor	Up to 3 (THDU < 5%)				
Load power factor	0.7 leading to 0.5 lagging without derating					
Battery (VRLA)	Charging power in % of output power	35% at ≤ 80% load, 12% at 100% load			40% at ≤ 80% load, 15% at 100% load	
	Maximum charging power (kW)	90 at 100% load, 262 at <80% load			112.5 at 100% load, 300 at 80% load	
	Nominal battery voltage (VDC)	480				
	Nominal float voltage (VDC)	546				
	End of discharge voltage (full load) (VDC)	384				
	End of discharge voltage (no load) (VDC)	420				
	Battery current at full load and nominal battery voltage (A)	1634				
	Battery current at full load and minimum battery voltage (A)	2043				
	Maximum short circuit rating	50 kA				
	Maximum battery backup time	Unlimited				
	Temperature compensation (per cell)	-3.3 mV per °C for T ≥ 25 °C, 0 mV per °C for T < 25 °C				
	Ripple current	< 5% C20 (5-minute backup time)				
	Battery test	Manual/automatic (selectable)				
	Deep discharge protection	Yes				
Recharge according to battery temperature	Yes					

29. Per NEC 250.30.

30. 4-wire connection with neutral is not compliant per FCC regulations for the 1500 kW I/O cabinet.

31. 125% for 480 V.

32. Minimum short circuit rating for output takes backfeeding energy through the bypass of parallel UPSs into consideration.

33. Maximum short circuit rating for output takes backfeeding energy through the bypass of parallel UPSs into consideration.

Specifications for 800 kW UPS

	Voltage (V)	380	400	415	440	480
Input	Connections	IEC: L1, L2, L3, PE ³⁴ UL: L1, L2, L3 + G ³⁵				
	Input voltage range (V) ³⁶	340-456	340-480	353-498	374-528	408-576
	Frequency (Hz)	40-70				
	Nominal input current (A)	1307	1239	1193	1120	1033
	Maximum input current (A) ³⁷	1474	1415	1363	1279	1212
	Input current limitation (A)	1424			1331	1216
	Minimum short circuit rating	Dependent on upstream protection. See section for ' Recommended upstream protection and cable sizes – IEC ' for details.				
	Maximum short circuit rating	100 kA RMS				
	Total harmonic distortion (THDI)	<3% at 100% load, <4% at 50% load, <9% at 25% load				
	Input power factor	0.99 at >40% load, 0.98 at >20% load, 0.97 at >10% load				
	Protection	Contactors				
	Ramp-in	Adaptive 1-300 seconds				
Bypass	Connections	IEC 1250 kW I/O and 1500 kW I/O: L1, L2, L3, N, PE or L1, L2, L3, PE ³⁸ UL 1250 kW I/O: L1, L2, L3, G or L1, L2, L3, N, G UL 1500 kW I/O ³⁹ : L1, L2, L3, G				
	Bypass voltage range (V)	342-418	360-440	374-457	396-484	432-528
	Frequency (Hz)	50 or 60				
	Frequency range (Hz)	Programmable: ±0.1, ±3, ±10. Default is ±3				
	Nominal bypass current (A)	1302	1236	1191	1124	1027
	Minimum short circuit rating	Dependent on upstream protection. See section for ' Recommended upstream protection and cable sizes – IEC ' for details.				
	Maximum short circuit rating	1250 kW I/O: 100 kA I _{cw} 1500 kW I/O: 100 kA RMS (conditioned by an internal molded switch with 90 kA peak magnetic trip)				
	Thyristor I ² t (kA*s ²)	9680 (1250 kW I/O)				9165 (1250 kW I/O)
	BF2 magnetic trip	1250 kW I/O: 39 kA 1500 kW I/O: 39 kA				
	Protection	1250 kW I/O with preinstalled backfeed breaker BF2: Molded switch with trip for backfeed protection 1250 kW I/O with GVXOPT001 installed: Molded switch with trip for backfeed protection 1500 kW I/O with preinstalled backfeed breaker BF2: Molded switch with trip for backfeed protection				

34. TN, TT, and IT power distribution systems are supported.

35. WYE source – solid grounded and high resistance grounded sources are supported. Corner (line) grounding is not permitted.

36. The system can operate at 600 V for 1 minute.

37. At nominal input voltage and full charge.

38. TN, TT, and IT power distribution systems with no earthed line conductors are supported.

39. 4-wire connection with neutral is not compliant per FCC regulations for the 1500 kW I/O cabinet.

	Voltage (V)	380	400	415	440	480
Output	Connections	IEC 1250 kW I/O and 1500 kW I/O: L1, L2, L3, N, PE or L1, L2, L3, PE UL 1250 kw I/O: L1, L2, L3, G, GEC ⁴⁰ or L1, L2, L3, N, G UL 1500 kW I/O ⁴¹ : L1, L2, L3, G, GEC ⁴⁰				
	Overload capacity	Normal operation: 150% for 1 minute, 125% for 10 minutes Battery operation: 128% for 10 seconds, 115% for 1 minute Bypass operation: 110% ⁴² continuous, 1000% for 60 milliseconds for systems with 1250 kW I/O cabinet, and 1000% for 100 milliseconds for systems with 1500 kW I/O cabinet				
	Output voltage tolerance	Balanced load: ±1%, Unbalanced load: ±3%				
	Dynamic load response	±5% after 2 ms, ±1% after 50 ms				
	Output power factor	1				
	Nominal output current (A)	1216	1155	1113	1050	962
	Minimum short circuit rating ⁴³	Dependent on upstream protection. See section for ' Recommended upstream protection and cable sizes – IEC ' for details.				
	Maximum short circuit rating ⁴⁴	100 kA RMS				
	Inverter output short circuit capabilities	Varies with time. See graph and table values in Inverter Short-Circuit Capabilities (Bypass not Available), page 39.				
	Total harmonic distortion (THDU)	<2% at 100% linear load, <3% at 100% non-linear load				
	Output frequency (Hz)	50/60 (synchronized to bypass), 50/60 Hz ±0.1% (free-running)				
	Slew rate (Hz/sec)	Programmable: 0.25, 0.5, 1, 2, 4, 6				
	Output performance classification (according to IEC/ EN62040-3)	Double-conversion: VFI-SS-111				
	Load crest factor	Up to 3 (THDU < 5%)				
Load power factor	0.7 leading to 0.5 lagging without derating					
Battery (VRLA)	Charging power in % of output power	35% at ≤ 80% load, 12% at 100% load			40% at ≤ 80% load, 15% at 100% load	
	Maximum charging power (kW)	96 at 100% load, 280 at <80% load			120 at 100% load, 320 at 80% load	
	Nominal battery voltage (VDC)	480				
	Nominal float voltage (VDC)	546				
	End of discharge voltage (full load) (VDC)	384				
	End of discharge voltage (no load) (VDC)	420				
	Battery current at full load and nominal battery voltage (A)	1743				
	Battery current at full load and minimum battery voltage (A)	2179				
	Maximum short circuit rating	50 kA				
	Maximum battery backup time	Unlimited				
	Temperature compensation (per cell)	-3.3 mV per °C for T ≥ 25 °C, 0 mV per °C for T < 25 °C				
	Ripple current	< 5% C20 (5-minute backup time)				
	Battery test	Manual/automatic (selectable)				
	Deep discharge protection	Yes				
Recharge according to battery temperature	Yes					

40. Per NEC 250.30.

41. 4-wire connection with neutral is not compliant per FCC regulations for the 1500 kW I/O cabinet.

42. 125% for 480 V.

43. Minimum short circuit rating for output takes backfeeding energy through the bypass of parallel UPSs into consideration.

44. Maximum short circuit rating for output takes backfeeding energy through the bypass of parallel UPSs into consideration.

Specifications for 1000 kW UPS

	Voltage (V)	380	400	415	440	480
Input	Connections	IEC: L1, L2, L3, PE ⁴⁵ UL: L1, L2, L3 + G ⁴⁶				
	Input voltage range (V) ⁴⁷	340-456	340-480	353-498	374-528	408-576
	Frequency (Hz)	40-70				
	Nominal input current (A)	1633	1549	1492	1397	1291
	Maximum input current (A) ⁴⁸	1842	1770	1704	1595	1514
	Input current limitation (A)	1780			1664	1520
	Minimum short circuit rating	Dependent on upstream protection. See section for 'Recommended upstream protection and cable sizes – IEC' for details.				
	Maximum short circuit rating	100 kA RMS				
	Total harmonic distortion (THDI)	<3% at 100% load, <4% at 50% load, <9% at 25% load				
	Input power factor	0.99 at >40% load, 0.98 at >20% load, 0.97 at >10% load				
	Protection	Contactors				
	Ramp-in	Adaptive 1-300 seconds				
Bypass	Connections	IEC 1250 kW I/O and 1500 kW I/O: L1, L2, L3, N, PE or L1, L2, L3, PE ⁴⁹ UL 1250 kW I/O: L1, L2, L3, G or L1, L2, L3, N, G UL 1500 kW I/O ⁵⁰ : L1, L2, L3, G				
	Bypass voltage range (V)	342-418	360-440	374-457	396-484	432-528
	Frequency (Hz)	50 or 60				
	Frequency range (Hz)	Programmable: ±0.1, ±3, ±10. Default is ±3				
	Nominal bypass current (A)	1627	1545	1489	1405	1284
	Minimum short circuit rating	Dependent on upstream protection. See section for 'Recommended upstream protection and cable sizes – IEC' for details.				
	Maximum short circuit rating	1250 kW I/O: 100 kA I _{cw} 1500 kW I/O: 100 kA RMS (conditioned by an internal molded switch with 90 kA peak magnetic trip)				
	Thyristor I ² t (kA*s ²)	1250 kW I/O: 9680 1500 kW I/O: 16245			1250 kW I/O: 9165 1500 kW I/O: 16245	
	BF2 magnetic trip	1250 kW I/O: 39 kA 1500 kW I/O: 39 kA				
	Protection	1250 kW I/O with preinstalled backfeed breaker BF2: Molded switch with trip for backfeed protection 1250 kW I/O with GVXOPT001 installed: Molded switch with trip for backfeed protection 1500 kW I/O with preinstalled backfeed breaker BF2: Molded switch with trip for backfeed protection				

45. TN, TT, and IT power distribution systems are supported.

46. WYE source – solid grounded and high resistance grounded sources are supported. Corner (line) grounding is not permitted.

47. The system can operate at 600 V for 1 minute.

48. At nominal input voltage and full charge.

49. TN, TT, and IT power distribution systems with no earthed line conductors are supported.

50. 4-wire connection with neutral is not compliant per FCC regulations for the 1500 kW I/O cabinet.

	Voltage (V)	380	400	415	440	480
Output	Connections	IEC 1250 kW I/O and 1500 kW I/O: L1, L2, L3, N, PE or L1, L2, L3, PE UL 1250 kw I/O: L1, L2, L3, G, GEC ⁵¹ or L1, L2, L3, N, G UL 1500 kW I/O ⁵² : L1, L2, L3, G, GEC ⁵¹				
	Overload capacity	Normal operation: 150% for 1 minute, 125% for 10 minutes Battery operation: 128% for 10 seconds, 115% for 1 minute Bypass operation: 110% ⁵³ continuous, 1000% for 60 milliseconds for systems with 1250 kW I/O cabinet, and 1000% for 100 milliseconds for systems with 1500 kW I/O cabinet				
	Output voltage tolerance	Balanced load: ±1%, Unbalanced load: ±3%				
	Dynamic load response	±5% after 2 ms, ±1% after 50 ms				
	Output power factor	1				
	Nominal output current (A)	1519	1443	1391	1312	1203
	Minimum short circuit rating ⁵⁴	Dependent on upstream protection. See section for ' Recommended upstream protection and cable sizes – IEC ' for details.				
	Maximum short circuit rating ⁵⁵	100 kA RMS				
	Inverter output short circuit capabilities	Varies with time. See graph and table values in Inverter Short-Circuit Capabilities (Bypass not Available), page 39.				
	Total harmonic distortion (THDU)	<2% at 100% linear load, <3% at 100% non-linear load				
	Output frequency (Hz)	50/60 (synchronized to bypass), 50/60 Hz ±0.1% (free-running)				
	Slew rate (Hz/sec)	Programmable: 0.25, 0.5, 1, 2, 4, 6				
	Output performance classification (according to IEC/ EN62040-3)	Double-conversion: VFI-SS-111				
	Load crest factor	Up to 3 (THDU < 5%)				
	Load power factor	0.7 leading to 0.5 lagging without derating				
Battery (VRLA)	Charging power in % of output power	35% at ≤ 80% load, 12% at 100% load				40% at ≤ 80% load, 15% at 100% load
	Maximum charging power (kW)	120 at 100% load, 350 at <80% load				150 at 100% load, 400 at <80% load
	Nominal battery voltage (VDC)	480				
	Nominal float voltage (VDC)	546				
	End of discharge voltage (full load) (VDC)	384				
	End of discharge voltage (no load) (VDC)	420				
	Battery current at full load and nominal battery voltage (A)	2179				
	Battery current at full load and minimum battery voltage (A)	2724				
	Maximum short circuit rating	50 kA				
	Maximum battery backup time	Unlimited				
	Temperature compensation (per cell)	-3.3 mV per °C for T ≥ 25 °C, 0 mV per °C for T < 25 °C				
	Ripple current	< 5% C20 (5-minute backup time)				
	Battery test	Manual/automatic (selectable)				
	Deep discharge protection	Yes				
Recharge according to battery temperature	Yes					

51. Per NEC 250.30.

52. 4-wire connection with neutral is not compliant per FCC regulations for the 1500 kW I/O cabinet.

53. 125% for 480 V.

54. Minimum short circuit rating for output takes backfeeding energy through the bypass of parallel UPSs into consideration.

55. Maximum short circuit rating for output takes backfeeding energy through the bypass of parallel UPSs into consideration.

Specifications for 1100 kW UPS

	Voltage (V)	380	400	415	440	480
Input	Connections	IEC: L1, L2, L3, PE ⁵⁶ UL: L1, L2, L3 + G ⁵⁷				
	Input voltage range (V) ⁵⁸	340-456	340-480	353-498	374-528	408-576
	Frequency (Hz)	40-70				
	Nominal input current (A)	1796	1704	1641	1540	1421
	Maximum input current (A) ⁵⁹	2026	1947	1874	1759	1666
	Input current limitation (A)	1958			1830	1672
	Minimum short circuit rating	Dependent on upstream protection. See section for ' Recommended upstream protection and cable sizes – IEC ' for details.				
	Maximum short circuit rating	100 kA RMS				
	Total harmonic distortion (THDI)	<3% at 100% load, <4% at 50% load, <9% at 25% load				
	Input power factor	0.99 at >40% load, 0.98 at >20% load, 0.97 at >10% load				
	Protection	Contactors				
	Ramp-in	Adaptive 1-300 seconds				
Bypass	Connections	IEC 1250 kW I/O and 1500 kW I/O: L1, L2, L3, N, PE or L1, L2, L3, PE ⁶⁰ UL 1250 kW I/O: L1, L2, L3, G or L1, L2, L3, N, G UL 1500 kW I/O ⁶¹ : L1, L2, L3, G				
	Bypass voltage range (V)	342-418	360-440	374-457	396-484	432-528
	Frequency (Hz)	50 or 60				
	Frequency range (Hz)	Programmable: ±0.1, ±3, ±10. Default is ±3				
	Nominal bypass current (A)	1789	1700	1639	1545	1412
	Minimum short circuit rating	Dependent on upstream protection. See section for ' Recommended upstream protection and cable sizes – IEC ' for details.				
	Maximum short circuit rating	1250 kW I/O: 100 kA I _{cw} 1500 kW I/O: 100 kA RMS (conditioned by an internal molded switch with 90 kA peak magnetic trip)				
	Thyristor I ² t (kA*s ²)	9680 (1250 kW I/O)				9165 (1250 kW I/O)
	BF2 magnetic trip	1250 kW I/O: 39 kA 1500 kW I/O: 39 kA				
	Protection	1250 kW I/O with preinstalled backfeed breaker BF2: Molded switch with trip for backfeed protection 1250 kW I/O with GVXOPT001 installed: Molded switch with trip for backfeed protection 1500 kW I/O with preinstalled backfeed breaker BF2: Molded switch with trip for backfeed protection				

56. TN, TT, and IT power distribution systems are supported.

57. WYE source – solid grounded and high resistance grounded sources are supported. Corner (line) grounding is not permitted.

58. The system can operate at 600 V for 1 minute.

59. At nominal input voltage and full charge.

60. TN, TT, and IT power distribution systems with no earthed line conductors are supported.

61. 4-wire connection with neutral is not compliant per FCC regulations for the 1500 kW I/O cabinet.

	Voltage (V)	380	400	415	440	480
Output	Connections	IEC 1250 kW I/O and 1500 kW I/O: L1, L2, L3, N, PE or L1, L2, L3, PE UL 1250 kw I/O: L1, L2, L3, G, GEC ⁶² or L1, L2, L3, N, G UL 1500 kW I/O ⁶³ : L1, L2, L3, G, GEC ⁶²				
	Overload capacity	Normal operation: 150% for 1 minute, 125% for 10 minutes Battery operation: 128% for 10 seconds, 115% for 1 minute Bypass operation: 110% ⁶⁴ continuous, 1000% for 60 milliseconds for systems with 1250 kW I/O cabinet, and 1000% for 100 milliseconds for systems with 1500 kW I/O cabinet				
	Output voltage tolerance	Balanced load: ±1%, Unbalanced load: ±3%				
	Dynamic load response	±5% after 2 ms, ±1% after 50 ms				
	Output power factor	1				
	Nominal output current (A)	1671	1588	1530	1443	1323
	Minimum short circuit rating ⁶⁵	Dependent on upstream protection. See section for ' Recommended upstream protection and cable sizes – IEC ' for details.				
	Maximum short circuit rating ⁶⁶	100 kA RMS				
	Inverter output short circuit capabilities	Varies with time. See graph and table values in Inverter Short-Circuit Capabilities (Bypass not Available), page 39.				
	Total harmonic distortion (THDU)	<2% at 100% linear load, <3% at 100% non-linear load				
	Output frequency (Hz)	50/60 (synchronized to bypass), 50/60 Hz ±0.1% (free-running)				
	Slew rate (Hz/sec)	Programmable: 0.25, 0.5, 1, 2, 4, 6				
	Output performance classification (according to IEC/ EN62040-3)	Double-conversion: VFI-SS-111				
	Battery (VRLA)	Load crest factor	Up to 3 (THDU < 5%)			
Load power factor		0.7 leading to 0.5 lagging without derating				
Charging power in % of output power		35% at ≤ 80% load, 12% at 100% load				40% at ≤ 80% load, 15% at 100% load
Maximum charging power (kW)		132 at 100% load, 385 at <80% load				165 at 100% load, 440 at <80% load
Nominal battery voltage (VDC)		480				
Nominal float voltage (VDC)		546				
End of discharge voltage (full load) (VDC)		384				
End of discharge voltage (no load) (VDC)		420				
Battery current at full load and nominal battery voltage (A)		2397				
Battery current at full load and minimum battery voltage (A)		2996				
Maximum short circuit rating		50 kA				
Maximum battery backup time		Unlimited				
Temperature compensation (per cell)		-3.3 mV per °C for T ≥ 25 °C, 0 mV per °C for T < 25 °C				
Ripple current		< 5% C20 (5-minute backup time)				
Battery test	Manual/automatic (selectable)					
Deep discharge protection	Yes					
Recharge according to battery temperature	Yes					

62. Per NEC 250.30.

63. 4-wire connection with neutral is not compliant per FCC regulations for the 1500 kW I/O cabinet.

64. 125% for 480 V.

65. Minimum short circuit rating for output takes backfeeding energy through the bypass of parallel UPSs into consideration.

66. Maximum short circuit rating for output takes backfeeding energy through the bypass of parallel UPSs into consideration.

Specifications for 1250 kW UPS

	Voltage (V)	380	400	415	440	480
Input	Connections	IEC: L1, L2, L3, PE ⁶⁷ UL: L1, L2, L3 + G ⁶⁸				
	Input voltage range (V) ⁶⁹	340-456	340-480	353-498	374-528	408-576
	Frequency (Hz)	40-70				
	Nominal input current (A)	2041	1937	1865	1750	1615
	Maximum input current (A) ⁷⁰	2303	2212	2130	1999	1893
	Input current limitation (A)	2225			2080	1900
	Minimum short circuit rating	Dependent on upstream protection. See section for ' Recommended upstream protection and cable sizes – IEC ' for details.				
	Maximum short circuit rating	100 kA RMS				
	Total harmonic distortion (THDI)	<3% at 100% load, <4% at 50% load, <9% at 25% load				
	Input power factor	0.99 at >40% load, 0.98 at >20% load, 0.97 at >10% load				
	Protection	Contactors				
	Ramp-in	Adaptive 1-300 seconds				
Bypass	Connections	IEC 1250 kW I/O and 1500 kW I/O: L1, L2, L3, N, PE or L1, L2, L3, PE ⁷¹ UL 1250 kW I/O: L1, L2, L3, G or L1, L2, L3, N, G UL 1500 kW I/O ⁷² : L1, L2, L3, G				
	Bypass voltage range (V)	342-418	360-440	374-457	396-484	432-528
	Frequency (Hz)	50 or 60				
	Frequency range (Hz)	Programmable: ±0.1, ±3, ±10. Default is ±3				
	Nominal bypass current (A)	2033	1931	1862	1756	1605
	Minimum short circuit rating	Dependent on upstream protection. See section for ' Recommended upstream protection and cable sizes – IEC ' for details.				
	Maximum short circuit rating	1250 kW I/O: 100 kA I _{cw} 1500 kW I/O: 100 kA RMS (conditioned by an internal molded switch with 90 kA peak magnetic trip)				
	Thyristor I ² t (kA*s ²)	1250 kW I/O: 9680 1500 kW I/O: 16245			1250 kW I/O: 9165 1500 kW I/O: 16245	
	BF2 magnetic trip	1250 kW I/O: 39 kA 1500 kW I/O: 39 kA				
	Protection	1250 kW I/O with preinstalled backfeed breaker BF2: Molded switch with trip for backfeed protection 1250 kW I/O with GVXOPT001 installed: Molded switch with trip for backfeed protection 1500 kW I/O with preinstalled backfeed breaker BF2: Molded switch with trip for backfeed protection				

67. TN, TT, and IT power distribution systems are supported.

68. WYE source – solid grounded and high resistance grounded sources are supported. Corner (line) grounding is not permitted.

69. The system can operate at 600 V for 1 minute.

70. At nominal input voltage and full charge.

71. TN, TT, and IT power distribution systems with no earthed line conductors are supported.

72. 4-wire connection with neutral is not compliant per FCC regulations for the 1500 kW I/O cabinet.

	Voltage (V)	380	400	415	440	480
Output	Connections	IEC 1250 kW I/O and 1500 kW I/O: L1, L2, L3, N, PE or L1, L2, L3, PE UL 1250 kw I/O: L1, L2, L3, G, GEC ⁷³ or L1, L2, L3, N, G UL 1500 kW I/O ⁷⁴ : L1, L2, L3, G, GEC ⁷³				
	Overload capacity	Normal operation: 150% for 1 minute, 125% for 10 minutes Battery operation: 128% for 10 seconds, 115% for 1 minute Bypass operation: 110% ⁷⁵ continuous, 1000% for 60 milliseconds for systems with 1250 kW I/O cabinet, and 1000% for 100 milliseconds for systems with 1500 kW I/O cabinet				
	Output voltage tolerance	Balanced load: ±1%, Unbalanced load: ±3%				
	Dynamic load response	±5% after 2 ms, ±1% after 50 ms				
	Output power factor	1				
	Nominal output current (A)	1899	1804	1739	1640	1504
	Minimum short circuit rating ⁷⁶	Dependent on upstream protection. See section for ' Recommended upstream protection and cable sizes – IEC ' for details.				
	Maximum short circuit rating ⁷⁷	100 kA RMS				
	Inverter output short circuit capabilities	Varies with time. See graph and table values in Inverter Short-Circuit Capabilities (Bypass not Available), page 39.				
	Total harmonic distortion (THDU)	<2% at 100% linear load, <3% at 100% non-linear load				
	Output frequency (Hz)	50/60 (synchronized to bypass), 50/60 Hz ±0.1% (free-running)				
	Slew rate (Hz/sec)	Programmable: 0.25, 0.5, 1, 2, 4, 6				
	Output performance classification (according to IEC/ EN62040-3)	Double-conversion: VFI-SS-111				
	Load crest factor	Up to 3 (THDU < 5%)				
	Load power factor	0.7 leading to 0.5 lagging without derating				
Battery (VRLA)	Charging power in % of output power	35% at ≤ 80% load, 12% at 100% load			40% at ≤ 80% load, 15% at 100% load	
	Maximum charging power (kW)	150 at 100% load, 437 at <80% load			187.5 at 100% load, 500 at <80% load	
	Nominal battery voltage (VDC)	480				
	Nominal float voltage (VDC)	546				
	End of discharge voltage (full load) (VDC)	384				
	End of discharge voltage (no load) (VDC)	420				
	Battery current at full load and nominal battery voltage (A)	2724				
	Battery current at full load and minimum battery voltage (A)	3405				
	Maximum short circuit rating	50 kA				
	Maximum battery backup time	1 hour				
	Temperature compensation (per cell)	-3.3 mV per °C for T ≥ 25 °C, 0 mV per °C for T < 25 °C				
	Ripple current	< 5% C20 (5-minute backup time)				
	Battery test	Manual/automatic (selectable)				
	Deep discharge protection	Yes				
Recharge according to battery temperature	Yes					

73. Per NEC 250.30.

74. 4-wire connection with neutral is not compliant per FCC regulations for the 1500 kW I/O cabinet.

75. 125% for 480 V.

76. Minimum short circuit rating for output takes backfeeding energy through the bypass of parallel UPSs into consideration.

77. Maximum short circuit rating for output takes backfeeding energy through the bypass of parallel UPSs into consideration.

Recommended Upstream Protection and Cable Sizes – IEC

 DANGER
<p>HAZARD OF ELECTRIC SHOCK, EXPLOSION, OR ARC FLASH</p> <p>An easily accessible breaker is required for upstream protection. Maximum fault current disconnection time: 46 seconds at 200% input.</p> <p>Failure to follow these instructions will result in death or serious injury.</p>

NOTE: Overcurrent protection is to be provided by others.

Cable sizes in this manual are based on table B.52.12 and B.52.13 of IEC 60364-5-52 with the following assertions:

- 90 °C conductors
- An ambient temperature of 30 °C
- Use of copper or aluminum conductors
- Installation method F4 for DC cables and installation method F5 for AC cables, corrected for single layer in perforated cable tray.

PE cables are sized in accordance with IEC 60364-5-54 table 54.2 Minimum cross-sectional area of protective conductors.

NOTE: Always consider the PE size according to the complete electrical installation. Minimum size of the PE conductor must comply with local safety regulations for high PE conductor current equipment.

If the ambient temperature is greater than 30 °C, larger conductors are to be selected in accordance with the correction factors of the IEC.

NOTE: The use of aluminum conductors can limit the number of parallel Lithium-ion battery cabinets. Contact Schneider Electric for more information.

<h2>NOTICE</h2>
<p>RISK OF EQUIPMENT DAMAGE</p> <p>To ensure correct load sharing in bypass operation in a parallel system, the following recommendations apply:</p> <ul style="list-style-type: none"> • The bypass cables must be of the same length for all UPSs. • The output cables must be of the same length for all UPSs. • The input cables must be of the same length for all UPSs in a single mains system. • Cable formation recommendations must be followed. • The reactance of busbar layout in the bypass/input and output switchgear must be the same for all UPSs. <p>If the above recommendations are not followed the result can be uneven load sharing in bypass and overload of individual UPSs.</p> <p>Failure to follow these instructions can result in equipment damage.</p>

<h2>NOTICE</h2>
<p>RISK OF UNINTENTIONAL DEVICE OPERATION</p> <p>If a residual current-operated protective device (RCD-B) is used upstream as ground fault protection, then the RCD-B shall be sized to not trip on the leakage current of this product. The start-up leakage current can be up to 3 A. The continuous maximum leakage current is 350 mA.</p> <p>Failure to follow these instructions can result in equipment damage.</p>

Upstream Protection for IEC and Minimum Prospective Phase-To-Earth Short Circuit at the UPS Input/Bypass Terminals

⚠️ ⚠️ DANGER

HAZARD OF ELECTRIC SHOCK, EXPLOSION, OR ARC FLASH

The upstream overcurrent protective device (and its settings) must be sized to ensure a disconnecting time within 0.2 seconds for a minimum prospective phase-to-earth short circuit current calculated or measured at the input/bypass terminals of the UPS.

Failure to follow these instructions will result in death or serious injury.

If the upstream overcurrent protective device is a breaker with adjustable short time protection, then it is possible to adjust the short time protection current and short time delay (if present) to meet the requirement of 0.2 seconds for a calculated or measured phase-to-earth prospective short circuit current at the input/bypass terminals of the UPS.

Recommended Upstream Protection and Cable Sizes for 500 kW UPS

	Maximum OCPD (A)				Cable size per phase (mm ²) Copper / Aluminum				PE cable size (mm ²) Copper / Aluminum			
	380	400	415	440	380	400	415	440	380	400	415	440
Input	1000 <i>I_r</i> =0.90	1000 <i>I_r</i> =0.90	1000 <i>I_r</i> =0.90	1000 <i>I_r</i> =0.90	2x240/ 3x185	2x240/ 3x185	2x240/ 3x185	2x240/ 3x185	1x240/ 2x150	1x240/ 2x150	1x240/ 2x150	1x240/ 2x150
Bypass	800 <i>I_r</i> =0.98	800 <i>I_r</i> =0.95	800 <i>I_r</i> =0.9	800 <i>I_r</i> =0.9	2x185/ 2x240	2x150/ 2x240	2x150/ 2x240	2x150/ 2x240	1x185/ 1x240	1x150/ 1x240	1x150/ 1x240	1x150/ 1x240
Output	800 <i>I_r</i> =0.98	800 <i>I_r</i> =0.95	800 <i>I_r</i> =0.9	800 <i>I_r</i> =0.9	2x185/ 2x240	2x150/ 2x240	2x150/ 2x240	2x150/ 2x240	1x185/ 1x240	1x150/ 1x240	1x150/ 1x240	1x150/ 1x240
Battery	1500	1500	1500	1500	3x185/ 3x240	3x185/ 3x240	3x185/ 3x240	3x185/ 3x240	2x150/ 2x185	2x150/ 2x185	2x150/ 2x185	2x150/ 2x185

Recommended Upstream Protection and Cable Sizes for 625 kW UPS

	Maximum OCPD (A)				Cable size per phase (mm ²) Copper / Aluminum				PE cable size (mm ²) Copper / Aluminum			
	380	400	415	440	380	400	415	440	380	400	415	440
Input	1250 <i>I_r</i> =0.9	1250 <i>I_r</i> =0.9	1250 <i>I_r</i> =0.9	1250 <i>I_r</i> =0.9	3x185/ 3x240	3x185/ 3x240	3x185/ 3x240	3x185/ 3x240	2x150/ 2x185	2x150/ 2x185	2x150/ 2x185	2x150/ 2x185
Bypass	1000 <i>I_r</i> =0.98	1000 <i>I_r</i> =0.95	1000 <i>I_r</i> =0.9	1000 <i>I_r</i> =0.9	2x240/ 3x240	2x240/ 3x185	2x240/ 3x185	2x240/ 3x185	1x240/ 2x185	1x240/ 2x150	1x240/ 2x150	1x240/ 2x150
Output	1000 <i>I_r</i> =0.98	1000 <i>I_r</i> =0.95	1000 <i>I_r</i> =0.9	1000 <i>I_r</i> =0.9	2x240/ 3x240	2x240/ 3x185	2x240/ 3x185	2x240/ 3x185	1x240/ 2x185	1x240/ 2x150	1x240/ 2x150	1x240/ 2x150
Battery	2000	2000	2000	2000	3x240/ 4x240	3x240/ 4x240	3x240/ 4x240	3x240/ 4x240	2x185/ 2x240	2x185/ 2x240	2x185/ 2x240	2x185/ 2x240

Recommended Upstream Protection and Cable Sizes for 750 kW UPS

Voltage (V)	Maximum OCPD (A)				Cable size per phase (mm ²) Copper / Aluminum				PE cable size (mm ²) Copper / Aluminum			
	380	400	415	440	380	400	415	440	380	400	415	440
Input	1600 I _r =0.9	1600 I _r =0.9	1600 I _r =0.9	1250 I _r =1.0	3x240/ 4x240	3x240/ 4x240	3x240/ 4x240	3x185 4x240	2x185/ 2x240	2x185/ 2x240	2x185/ 2x240	2x150/ 2x240
Bypass	1250 I _r =0.95	1250 I _r =0.9	1250 I _r =0.9	1000 I _r =1.0	3x185/ 4x185	3x185/ 3x240	3x185/ 3x240	2x240/ 3x240	2x150/ 2x185	2x150/ 2x185	2x150/ 2x185	1x240/ 2x185
Output	1250 I _r =0.95	1250 I _r =0.9	1250 I _r =0.9	1000 I _r =1.0	3x185/ 4x185	3x185/ 3x240	3x185/ 3x240	2x240/ 3x240	2x150/ 2x185	2x150/ 2x185	2x150/ 2x185	1x240/ 2x185
Battery	2500	2500	2500	2500	4x240/ 5x240	4x240/ 5x240	4x240/ 5x240	4x240/ 5x240	2x240/ 3x240	2x240/ 3x240	2x240/ 3x240	2x240/ 3x240

Recommended Upstream Protection and Cable Sizes for 800 kW UPS

Voltage (V)	Maximum OCPD (A)				Cable size per phase (mm ²) Copper / Aluminum				PE cable size (mm ²) Copper / Aluminum			
	380	400	415	440	380	400	415	440	380	400	415	440
Input	1600 I _r =0.9	1600 I _r =0.9	1600 I _r =0.9	1600 I _r =0.9	3x240/ 4x240	3x240/ 4x240	3x240/ 4x240	3x240/ 4x240	2x185/ 2x240	2x185/ 2x240	2x185/ 2x240	2x185/ 2x240
Bypass	1250 I _r =1.0	1250 I _r =0.95	1250 I _r =0.9	1250 I _r =0.9	3x185/ 4x240	3x185/ 4x185	3x185/ 3x240	3x185/ 3x240	2x150/ 2x185	2x150/ 2x185	2x150/ 2x185	2x150/ 2x185
Output	1250 I _r =1.0	1250 I _r =0.95	1250 I _r =0.9	1250 I _r =0.9	3x185/ 4x240	3x185/ 4x185	3x185/ 3x240	3x185/ 3x240	2x150/ 2x185	2x150/ 2x185	2x150/ 2x185	2x150/ 2x185
Battery	2500	2500	2500	2500	4x240/ 5x240	4x240/ 5x240	4x240/ 5x240	4x240/ 5x240	2x240/ 3x240	2x240/ 3x240	2x240/ 3x240	2x240/ 3x240

Recommended Upstream Protection and Cable Sizes for 1000 kW UPS

Voltage (V)	Maximum OCPD (A)				Cable size per phase (mm ²) Copper / Aluminum				PE cable size (mm ²) Copper / Aluminum			
	380	400	415	440	380	400	415	440	380	400	415	440
Input	2000 I _r =0.9	2000 I _r =0.9	2000 I _r =0.9	2000 I _r =0.9	4x240/ 6x240	4x240/ 6x240	4x240/ 6x240	4x240/ 6x240	2x240/ 3x240	2x240/ 3x240	2x240/ 3x240	2x240/ 3x240
Bypass	1600 I _r =0.98	1600 I _r =0.95	1600 I _r =0.9	1600 I _r =0.9	4x185/ 5x240	4x185/ 5x240	3x240/ 4x240	3x240/ 4x240	2x185/ 3x240	2x185/ 3x240	2x185/ 2x240	2x185/ 2x240
Output	1600 I _r =0.98	1600 I _r =0.98	1600 I _r =0.9	1600 I _r =0.9	4x240/ 6x240	4x240/ 6x240	3x240/ 6x240	3x240/ 6x240	2x240/ 3x240	2x240/ 3x240	2x240/ 3x240	2x240/ 3x240
Battery	3300	3300	3300	3300	5x240/ 7x240	5x240/ 7x240	5x240/ 7x240	5x240/ 7x240	3x240/ 4x240	3x240/ 4x240	3x240/ 4x240	3x240/ 4x240

Recommended Upstream Protection and Cable Sizes for 1100 kW UPS

NOTE: For a 1250 I/O cabinet, it is preferred to use flexible copper power cables with as small a diameter as possible. The number of power cables needed for this kW rating will make large and inflexible power cables more difficult to install.

Voltage (V)	Maximum OCPD (A)				Cable size per phase (mm ²) Copper / Aluminum				PE cable size (mm ²) Copper / Aluminum			
	380	400	415	440	380	400	415	440	380	400	415	440
Input	2000 I _r =0.98	2000 I _r =0.98	2000 I _r =0.98	2000 I _r =0.95	4x300/ 5x300	4x300/ 5x300	4x300/ 5x300	4x300/ 5x300	2x300/ 3x300	2x300/ 3x300	2x300/ 3x300	2x300/ 3x300
Bypass	2000 I _r =0.9	2000 I _r =0.9	1600 I _r =0.98	1600 I _r =0.95	4x240/ 5x300	4x240/ 5x300	3x300/ 4x300	3x300/ 4x300	2x240/ 3x300	2x240/ 3x300	2x240/ 2x300	2x240/ 2x300
Output	2000 I _r =0.9	2000 I _r =0.9	1600 I _r =0.98	1600 I _r =0.95	4x240/ 5x300	4x240/ 5x300	3x300/ 4x300	3x300/ 4x300	2x240/ 3x300	2x240/ 3x300	2x240/ 2x300	2x240/ 2x300
Battery	3300	3300	3300	3300	5x300/ 7x300	5x300/ 7x300	5x300/ 7x300	5x300/ 7x300	3x300/ 4x300	3x300/ 4x300	3x300/ 4x300	3x300/ 4x300

Recommended Upstream Protection and Cable Sizes for 1250 kW UPS

NOTE: For a 1250 I/O cabinet, it is preferred to use flexible copper power cables with as small a diameter as possible. The number of power cables needed for this kW rating will make large and inflexible power cables more difficult to install.

Voltage (V)	Maximum OCPD (A)				Cable size per phase (mm ²) Copper / Aluminum				PE cable size (mm ²) Copper / Aluminum			
	380	400	415	440	380	400	415	440	380	400	415	440
Input	2500 I _r =0.9	2500 I _r =0.9	2500 I _r =0.9	2500 I _r =0.9	5x240/ 6x300	5x240/ 6x300	5x240/ 6x300	5x240/ 6x300	3x240/ 3x300	3x240/ 3x300	3x240/ 3x300	3x240/ 3x300
Bypass	2000 I _r =0.98	2000 I _r =0.95	2000 I _r =0.9	2000 I _r =0.9	4x300/ 5x300	4x300/ 5x300	4x240/ 5x300	4x240/ 5x300	2x300/ 3x300	2x300/ 3x300	2x240/ 3x300	2x240/ 3x300
Output	2000 I _r =0.98	2000 I _r =0.95	2000 I _r =0.9	2000 I _r =0.9	4x300/ 5x300	4x300/ 5x300	4x240/ 5x300	4x240/ 5x300	2x300/ 3x300	2x300/ 3x300	2x240/ 3x300	2x240/ 3x300
Battery	4000	4000	4000	4000	6x300/ 7x300	6x300/ 7x300	6x300/ 7x300	6x300/ 7x300	3x300/ 4x300	3x300/ 4x300	3x300/ 4x300	3x300/ 4x300

Recommended Bolt and Lug Sizes for IEC

Cable size mm ²	Bolt size	Cable lug type
16	M10 x 40 mm	TLK 16-10
25	M10 x 40 mm	TLK 25-10
35	M10 x 40 mm	TLK 35-10
50	M10 x 40 mm	TLK 50-10
70	M10 x 40 mm	TLK 70-10
95	M10 x 40 mm	TLK 95-10
120	M10 x 40 mm	TLK 120-10
150	M10 x 40 mm	TLK 150-10
185	M10 x 40 mm	TLK 185-10
240	M10 x 40 mm	TLK 240-10

Recommended Upstream Protection and Cable Sizes – UL

⚠ CAUTION

HAZARD OF FIRE

- Connect only to a circuit with the below specifications.
- Connect only to a circuit provided with a maximum branch circuit overcurrent protection, as specified in the UPS rating tables below, in accordance with the National Electrical Code, ANSI/NFPA70, and the Canadian Electrical Code, Part I, C22.1.

Failure to follow these instructions can result in injury or equipment damage.

NOTE: Overcurrent protection is to be provided by others.

NOTE: All wiring must comply with all applicable national and/or electrical code (National Electrical Code, ANSI/NFPA 70).

Cable sizes in this manual are based on Table 310.15 of the National Electrical Code 2014 (NEC) with the following assertions:

- 90 °C conductors (THHN) for 75 °C termination
- Not more than 3 current carrying conductors in each conduit
- An ambient temperature of max. 30 °C
- Use of copper or aluminium conductors
- 100% rated breakers
- Nominal operating conditions

If the ambient room temperature is greater than 30 °C, use larger or additional parallel conductors in accordance with the correction factors of the NEC. The maximum allowable conductor size is 600 kcmil.

Equipment Grounding Conductors (EGC) are sized in accordance with NEC Article 250.122 and Table 250.122 Minimum size equipment conductor for grounding equipment.

NOTE: Always consider the EGC size according to the complete electrical installation.

NOTE: The use of aluminium conductors can limit the number of parallel Lithium-ion battery cabinets. Contact Schneider Electric for more information.

NOTICE

RISK OF EQUIPMENT DAMAGE

To ensure correct load sharing in bypass operation in a parallel system, the following recommendations apply:

- The bypass cables must be of the same length for all UPSs.
- The output cables must be of the same length for all UPSs.
- The input cables must be of the same length for all UPSs in a single mains system.
- Cable formation recommendations must be followed.
- The reactance of busbar layout in the bypass/input and output switchgear must be the same for all UPSs.

If the above recommendations are not followed the result can be uneven load sharing in bypass and overload of individual UPSs.

Failure to follow these instructions can result in equipment damage.

Recommended Upstream Protection and Cable Sizes for 500 kW UPS

	Maximum OCPD (A)	Cable size per phase (AWG/kcmil) Copper / Aluminum	EGC cable size (AWG/kcmil) ⁷⁸ Copper / Aluminum
Input	800 ($I_r = 1.0$)	2x500 / 3x400	1x1/0 / 1x3/0
Bypass	700 ($I_r = 1.0$)	2x350 / 2x500	1x1/0 / 1x3/0
Output	700 ($I_r = 1.0$)	2x350 / 2x500	1x1/0 / 1x3/0
Battery	1600 ($I_r = 0.9$)	4x500 / 5x500	1x4/0 / 1x350

Recommended Upstream Protection and Cable Sizes for 625 kW UPS

	Maximum OCPD (A)	Cable size per phase (AWG/kcmil) Copper / Aluminum	EGC cable size (AWG/kcmil) ⁷⁸ Copper / Aluminum
Input	1000 ($I_r = 1.0$)	3x400 / 3x600	1x2/0 / 1x4/0
Bypass	800 ($I_r = 1.0$)	2x600 / 3x400	1x1/0 / 1x3/0
Output	800 ($I_r = 1.0$)	2x600 / 3x400	1x1/0 / 1x3/0
Battery	2000 ($I_r = 0.9$)	5x500 / 6x500	1x250 / 1x400

Recommended Upstream Protection and Cable Sizes for 750 kW UPS

	Maximum OCPD (A)	Cable size per phase (AWG/kcmil) Copper / Aluminum	EGC cable size (AWG/kcmil) ⁷⁸ Copper / Aluminum
Input	1200 ($I_r = 1.0$)	3x600 / 4x500	1x3/0 / 1x250
Bypass	1000 ($I_r = 1.0$)	3x400 / 3x600	1x2/0 / 1x4/0
Output	1000 ($I_r = 1.0$)	3x400 / 3x600	1x2/0 / 1x4/0
Battery	2500 ($I_r = 0.9$)	6x500 / 7x600	1x350 / 1x600

Recommended Upstream Protection and Cable Sizes for 800 kW UPS

	Maximum OCPD (A)	Cable size per phase (AWG/kcmil) Copper / Aluminum	EGC cable size (AWG/kcmil) ⁷⁸ Copper / Aluminum
Input	1600 ($I_r = 0.8$)	4x400 / 4x600	1x4/0 / 1x350
Bypass	1000	3x400 / 3x600	1x2/0 / 1x4/0
Output	1000	3x400 / 3x600	1x2/0 / 1x4/0
Battery	2500 ($I_r = 0.9$)	6x500 / 7x600	1x350 / 1x600

78. If the conductors are run in conduits, there must be one conductor in each conduit.

Recommended Upstream Protection and Cable Sizes for 1000 kW UPS

	Maximum OCPD (A)	Cable size per phase (AWG/kcmil) Copper / Aluminum	EGC cable size (AWG/kcmil) ⁷⁹ Copper / Aluminum
Input	1600 (I _r = 1.0)	4x600 / 5x600	1x4/0 / 1x350
Bypass	1600 (I _r = 0.8)	4x400 / 4x600	1x4/0 / 1x350
Output	1600 (I _r = 0.8)	4x400 / 4x600	1x4/0 / 1x350
Battery	3000 (I _r = 1.0)	8x500 / 9x600	1x400 / 1x600

Recommended Upstream Protection and Cable Sizes for 1100 kW UPS

NOTE: For a 1250 I/O cabinet, it is preferred to use flexible copper power cables with as small a diameter as possible. The number of power cables needed for this kW rating will make large and inflexible power cables more difficult to install.

	Maximum OCPD (A)	Cable size per phase (AWG/kcmil) Copper / Aluminum	EGC cable size (AWG/kcmil) ⁷⁹ Copper / Aluminum
Input	2000 (I _r = 0.9)	5x500 / 6x500	1x250 / 1x400
Bypass	1600 (I _r = 0.9)	4x500 / 5x500	1x4/0 / 1x350
Output	1600 (I _r = 0.9)	4x500 / 5x500	1x4/0 / 1x350
Battery	3000 (I _r = 1.0)	8x500 / 9x600	1x400 / 1x600

Recommended Upstream Protection and Cable Sizes for 1250 kW UPS

NOTE: For a 1250 I/O cabinet, it is preferred to use flexible copper power cables with as small a diameter as possible. The number of power cables needed for this kW rating will make large and inflexible power cables more difficult to install.

	Maximum OCPD (A)	Cable size per phase (AWG/kcmil) Copper / Aluminum	EGC cable size (AWG/kcmil) ⁷⁹ Copper / Aluminum
Input	2000 (I _r = 1.0)	5x600 / 6x600	1x250 / 1x400
Bypass	1600 (I _r = 1.0)	4x600 / 5x600	1x4/0 / 1x350
Output	1600 (I _r = 1.0)	4x600 / 5x600	1x4/0 / 1x350
Battery	4000 (I _r = 0.9)	9x600 / 11x600	2x250 / 2x400

79. If the conductors are run in conduits, there must be one conductor in each conduit.

Recommended Bolt and Lug Sizes for Copper Cables

Cable Size	Terminal Bolt Diameter	Cable Lug Type	Crimping Tool	Die
1/0 AWG	M12 x 35 mm	LCCF1/0-12-X	CT930	CD-920-2/0 Black P45
2/0 AWG	M12 x 35 mm	LCCF2/0-12-X	CT930	CD-920-3/0 Orange P50
3/0 AWG	M12 x 35 mm	LCCF3/0-12-X	CT930	CD-920-4/0 Purple P54
250 kcmil	M12 x 35 mm	LCCF250-12-X	CT-940CH/CT-2940	CD-920-300 White P66
300 kcmil	M12 x 35 mm	LCCF300-12-6	CT-940CH/CT-2940	CD-920-350 Red P71
400 kcmil	M12 x 35 mm	LCCF400-12-6	CT-940CH/CT-2940	CD-920-500 Brown P87
500 kcmil	M12 x 35 mm	LCCF500-12-6	CT-940CH/CT-2940	CD-920-500A Pink P99
600 kcmil	M12 x 40 mm	LCCF600-12-6	CT-940CH/CT-2940	CD-920-750 Black P106

Recommended Bolt and Lug Sizes for Aluminium Cables

Cable Size	Terminal Bolt Diameter	Cable Lug Type	Crimping Tool	Die
2/0 AWG	M12 x 40 mm	LAB2/0-12-5	CT930	Olive P54
3/0 AWG	M12 x 40 mm	LAB3/0-12-5	CT930	Ruby P60
250 kcmil	M12 x 40 mm	LAB250-12-5	CT930	Red P71
300 kcmil	M12 x 40 mm	LAB300-12-2	CT930	Blue P76
400 kcmil	M12 x 40 mm	LAB400-12-2	CT930	Green P94
500 kcmil	M12 x 40 mm	LAB500-12-2	CT930	Pink P99
600 kcmil	M12 x 40 mm	LAB600-12-2	CT930	Black P106

Inverter Short-Circuit Capabilities (Bypass not Available)

IK1 – Short-Circuit between a Phase and Neutral

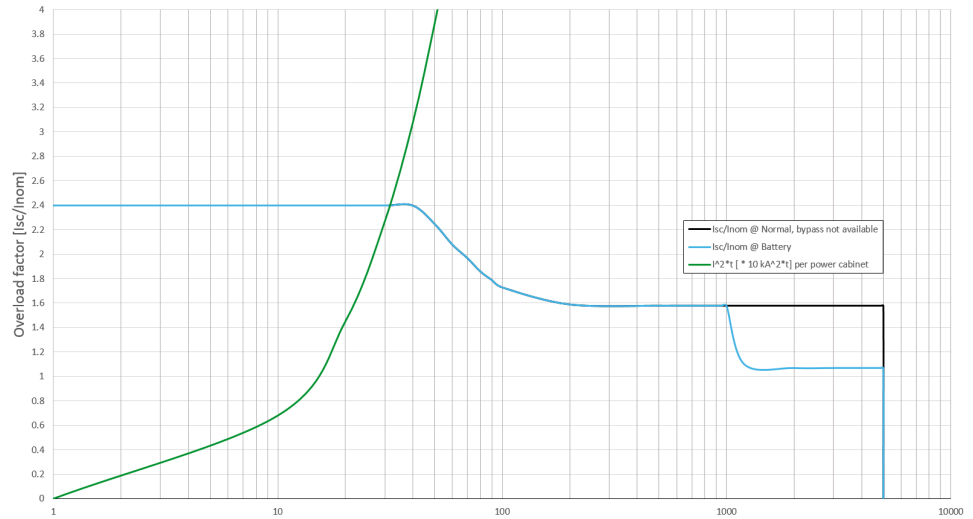

400 V IK1

S [kVA]	Ik10ms [A] Normal operation /Battery operation	Ik30ms [A] Normal operation /Battery operation	Ik100ms [A] Normal operation /Battery operation	Ik500ms [A] Normal operation /Battery operation	Ik1s [A] Normal operation /Battery operation	Ik5s [A] Normal operation /Battery operation	I² t total [A²s] Normal operation /Battery operation
250	840 /840	820 /840	610 /640	550 /550	550 /550	550 /360	1539100 /874180
500	1680 /1680	1640 /1680	1220 /1280	1100 /1100	1100 /1100	1100 /720	6156400 /3496720
750	2520 /2520	2460 /2520	1830 /1920	1650 /1650	1650 /1650	1650 /1080	13851900 /7867620
1000	3360 /3360	3280 /3360	2440 /2560	2200 /2200	2200 /2200	2200 /1440	24625600 /13986880
1250	4200 /4200	4100 /4200	3050 /3200	2750 /2750	2750 /2750	2750 /1800	38477500 /21854500
1500	5040 /5040	4920 /5040	3660 /3840	3300 /3300	3300 /3300	3300 /2160	55407600 /31470480

480 V IK1

S [kVA]	Ik10ms [A] Normal operation /Battery operation	Ik30ms [A] Normal operation /Battery operation	Ik100ms [A] Normal operation /Battery operation	Ik500ms [A] Normal operation /Battery operation	Ik1s [A] Normal operation /Battery operation	Ik5s [A] Normal operation /Battery operation	I² t total [A²s] Normal operation /Battery operation
250	– /810	– /810	– /570	– /290	– /290	– /290	– /493600
500	– /1620	– /1620	– /1140	– /580	– /580	– /580	– /1974400
750	– /2430	– /2430	– /1710	– /870	– /870	– /870	– /4442400
1000	– /3240	– /3240	– /2280	– /1160	– /1160	– /1160	– /7897600

480 V IK1 (Continued)

S [kVA]	Ik10ms [A] Normal operation /Battery operation	Ik30ms [A] Normal operation /Battery operation	Ik100ms [A] Normal operation /Battery operation	Ik500ms [A] Normal operation /Battery operation	Ik1s [A] Normal operation /Battery operation	Ik5s [A] Normal operation /Battery operation	I ² t total [A ² s] Normal operation /Battery operation
1250	— /4050	— /4050	— /2850	— /1450	— /1450	— /1450	— /12340000
1500	— /4860	— /4860	— /3420	— /1740	— /1740	— /1740	— /17769600

IK2 – Short-Circuit between Two Phases

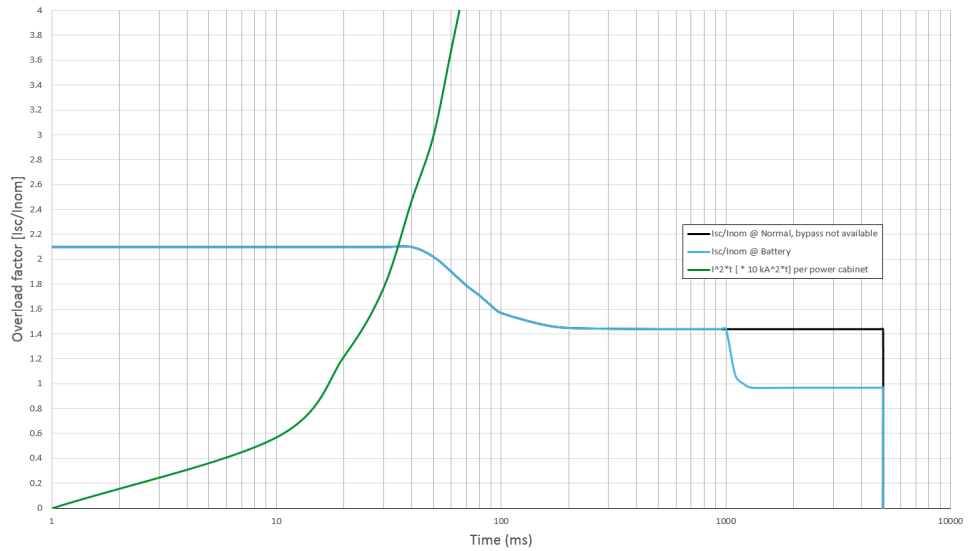

400 V IK2

S [kVA]	Ik10ms [A] Normal operation /Battery operation	Ik30ms [A] Normal operation /Battery operation	Ik100ms [A] Normal operation /Battery operation	Ik500ms [A] Normal operation /Battery operation	Ik1s [A] Normal operation /Battery operation	Ik5s [A] Normal operation /Battery operation	I ² t total [A ² s] Normal operation /Battery operation
250	780 /780	780 /780	600 /600	510 /510	510 /510	510 /330	1312100 /740520
500	1560 /1560	1560 /1560	1200 /1200	1020 /1020	1020 /1020	1020 /660	5248400 /2962080
750	2340 /2340	2340 /2340	1800 /1800	1530 /1530	1530 /1530	1530 /990	11808900 /6664680
1000	3120 /3120	3120 /3120	2400 /2400	2040 /2040	2040 /2040	2040 /1320	20993600 /11848320
1250	3900 /3900	3900 /3900	3000 /3000	2550 /2550	2550 /2550	2550 /1650	32802500 /18513000
1500	4680 /4680	4680 /4680	3600 /3600	3060 /3060	3060 /3060	3060 /1980	47235600 /26658720

480 V IK2

S [kVA]	Ik10ms [A] Normal operation /Battery operation	Ik30ms [A] Normal operation /Battery operation	Ik100ms [A] Normal operation /Battery operation	Ik500ms [A] Normal operation /Battery operation	Ik1s [A] Normal operation /Battery operation	Ik5s [A] Normal operation /Battery operation	I ² t total [A ² s] Normal operation /Battery operation
250	790 /790	770 /770	550 /550	430 /280	430 /280	280 /280	606450 /460820
500	1580 /1580	1540 /1540	1100 /1100	860 /560	860 /560	560 /560	2425800 /1843280
750	2370 /2370	2310 /2310	1650 /1650	1290 /840	1290 /840	840 /840	5458050 /4147380
1000	3160 /3160	3080 /3080	2200 /2200	1720 /1120	1720 /1120	1120 /1120	9703200 /7373120
1250	3950 /3950	3850 /3850	2750 /2750	2150 /1400	2150 /1400	1400 /1400	15161250 /11520500
1500	4740 /4740	4620 /4620	3300 /3300	2580 /1680	2580 /1680	1680 /1680	21832200 /16589520

IK3 – Short-Circuit between All Three Phases

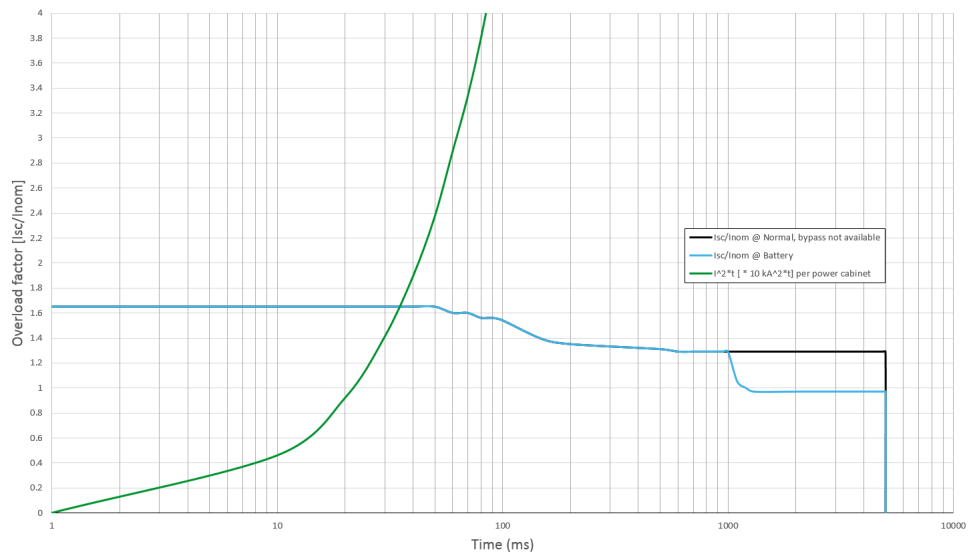

400 V IK3

S [kVA]	Ik10ms [A] Normal operation /Battery operation	Ik30ms [A] Normal operation /Battery operation	Ik100ms [A] Normal operation /Battery operation	Ik500ms [A] Normal operation /Battery operation	Ik1s [A] Normal operation /Battery operation	Ik5s [A] Normal operation /Battery operation	I ² t total [A ² s] Normal operation /Battery operation
250	720 /720	720 /720	670 /640	540 /360	540 /360	540 /360	1507600 /711360
500	1440 /1440	1440 /1440	1340 /1280	1080 /720	1080 /720	1080 /720	6030400 /2845440
750	2160 /2160	2160 /2160	2010 /1920	1620 /1080	1620 /1080	1620 /1080	13568400 /6402240
1000	2880 /2880	2880 /2880	2680 /2560	2160 /1440	2160 /1440	2160 /1440	24121600 /11381760
1250	3600 /3600	3600 /3600	3350 /3200	2700 /1800	2700 /1800	2700 /1800	37690000 /17784000
1500	4320 /4320	4320 /4320	4020 /3840	3240 /2160	3240 /2160	3240 /2160	54273600 /25608960

480 V IK3

S [kVA]	Ik10ms [A] Normal operation /Battery operation	Ik30ms [A] Normal operation /Battery operation	Ik100ms [A] Normal operation /Battery operation	Ik500ms [A] Normal operation /Battery operation	Ik1s [A] Normal operation /Battery operation	Ik5s [A] Normal operation /Battery operation	I² t total [A²s] Normal operation /Battery operation
250	670 /660	670 /660	610 /610	440 /440	360 /440	300 /300	580600 /589380
500	1340 /1320	1340 /1320	1220 /1220	880 /880	720 /880	600 /600	2322400 /2357520
650	1742 /1716	1742 /1716	1586 /1586	1144 /1144	936 /1144	780 /780	3924856 /3984209
1000	2680 /2640	2680 /2640	2440 /2440	1760 /1760	1440 /1760	1200 /1200	9289600 /9430080
1250	3350 /3300	3350 /3300	3050 /3050	2200 /2200	1800 /2200	1500 /1500	14515000 /14734500
1500	4020 /3960	4020 /3960	3660 /3660	2640 /2640	2160 /2640	1800 /1800	20901600 /21217680

Torque Specifications

⚠ ⚠ WARNING
HAZARD OF ELECTRIC SHOCK
All electrical connections must be torqued according to this table.
Failure to follow these instructions can result in death, serious injury, or equipment damage.

Bolt size	Torque
M6	5 Nm (3.69 lb-ft)
M8	17.5 Nm (12.91 lb-ft)
M10	30 Nm (22 lb-ft)
M12	50 Nm (36.87 lb-ft)

Environment

	Operating	Storage
Temperature	0 °C to 40 °C (32 °F to 104 °F) 0 °C to 50 °C (32 °F to 122 °F) when derated to 75% power ⁸⁰	-15 °C to 40 °C (5 °F to 104 °F) for systems with batteries -25 °C to 55 °C (-13 °F to 131 °F) for systems without batteries
Relative humidity	5-95% non-condensing	10-80% non-condensing
Elevation derating according to ANSI C57.96-1999 ⁸¹	1000 m (3300 ft): 1.000 1500 m (5000 ft): 0.975 2000 m (6600 ft): 0.950 2500 m (8300 ft): 0.925 3000 m (10000 ft): 0.900	0-15000 m (0-50000 ft)
Audible noise one meter (three feet) from unit	62 dB at 70% load 69.5 dB at 100% load for 400 V systems 68 dB at 100% load for 480 V systems	
Protection class	IP20	
Color	RAL 9003 white	

80. For temperatures between 40 °C (104 °F) and 50 °C (122 °F), the load power rating must be derated with 2.5% per °C of rated output power. Above 40 °C (104 °F) the minimum input voltage is 340 V, and from 380 V to 340 V, the charge power must be linearly derated from 12% to 1%.

81. Maximum operation elevation is 3000 m (10000 ft).

Compliance

Safety	IEC 62040-1: 2017, Edition 2.0, Uninterruptible Power Systems (UPS) - Part 1: Safety requirements UL 1778 5th edition
EMC/EMI/RFI	IEC 62040-2: 2016, 3rd edition Uninterruptible Power Systems (UPS) - Part 2: Electromagnetic compatibility (EMC) requirements C2 FCC 15B, class A
Performance	IEC 62040-3: 2011-03, 2nd edition Uninterruptible Power Systems (UPS) - Part 3: Method of specifying the performance and test requirements
Environmental	IEC 62040-4: 2013-04, 1st edition Uninterruptible Power Systems (UPS) - Part 4: Environmental aspects – Requirements and reporting
Markings	CE, C-Tick UL1778 Listing and CSA C22.2 NO.107.3
Transportation	ISTA 2B IEC 60721-4-2 Level 2M2
Seismic	OSHDP, IBC2012 and CBC2013 to $S_{DS} = 1.83 \text{ g}$
Overvoltage category	III
Earthing system	TN, TT, IT
Protective class	I
Pollution degree	2

Weights and Dimensions for UPSs with 1250 kW I/O Cabinet

Commercial reference		Weight kg (lbs)	Height mm (in)	Width mm (in)	Depth mm (in)
<ul style="list-style-type: none"> • GVX500K500NHS • GVX500K500NGS • GVX500K750NHS • GVX500K750NGS • GVX500K1000NHS • GVX500K1000NGS • GVX500K1250NHS • GVX500K1250NGS 	Total – Power cabinets – I/O cabinet	1700 (3748) 2 x 540 (2 x 1190) 620 (1367)	1970 (77.6)	2400 (94.5) 2 x 600 (2 x 23.6) 1200 (47.2)	900 (35.4)
<ul style="list-style-type: none"> • GVX625K625NHS • GVX625K625NGS • GVX625K1000NHS • GVX625K1000NGS • GVX750K500NHS • GVX750K500NGS • GVX750K750NHS • GVX750K750NGS • GVX750K1000NHS • GVX750K1000NGS • GVX750K1250NHS • GVX750K1250NGS 	Total – Power cabinets – I/O cabinet	2240 (4938) 3 x 540 (3 x 1190) 620 (1367)	1970 (77.6)	3000 (118.1) 3 x 600 (3 x 23.6) 1200 (47.2)	900 (35.4)
<ul style="list-style-type: none"> • GVX800K800NHS • GVX800K800NGS • GVX1000K750NHS • GVX1000K750NGS • GVX1000K1000NHS • GVX1000K1000NGS • GVX1000K1250NHS • GVX1000K1250NGS 	Total – Power cabinets – I/O cabinet	2780 (6129) 4 x 540 (4 x 1190) 620 (1367)	1970 (77.6)	3600 (141.7) 4 x 600 (4 x 23.6) 1200 (47.2)	900 (35.4)
<ul style="list-style-type: none"> • GVX1100K1100NHS • GVX1100K1100NGS • GVX1250K1000NHS • GVX1250K1000NGS • GVX1250K1250NHS • GVX1250K1250NGS 	Total – Power cabinets – I/O cabinet	3320 (7319) 5 x 540 (5 x 1190) 620 (1367)	1970 (77.6)	4200 (165.4) 5 x 600 (5 x 23.6) 1200 (47.2)	900 (35.4)
<ul style="list-style-type: none"> • GVX1500K1100NHS • GVX1500K1100NGS • GVX1500K1250NHS • GVX1500K1250NGS 	Total – Power cabinets – I/O cabinet	3860 (8510) 6 x 540 (6 x 1190) 620 (1367)	1970 (77.6)	4800 (189.0) 6 x 600 (6 x 23.6) 1200 (47.2)	900 (35.4)

Clearance for UPSs with 1250 kW I/O Cabinet

NOTE: Clearance dimensions are published for airflow and service access only. Consult with the local safety codes and standards for additional requirements in your local area.

NOTE: The UPS system can be placed up against a wall and there is no requirement for rear or side access.

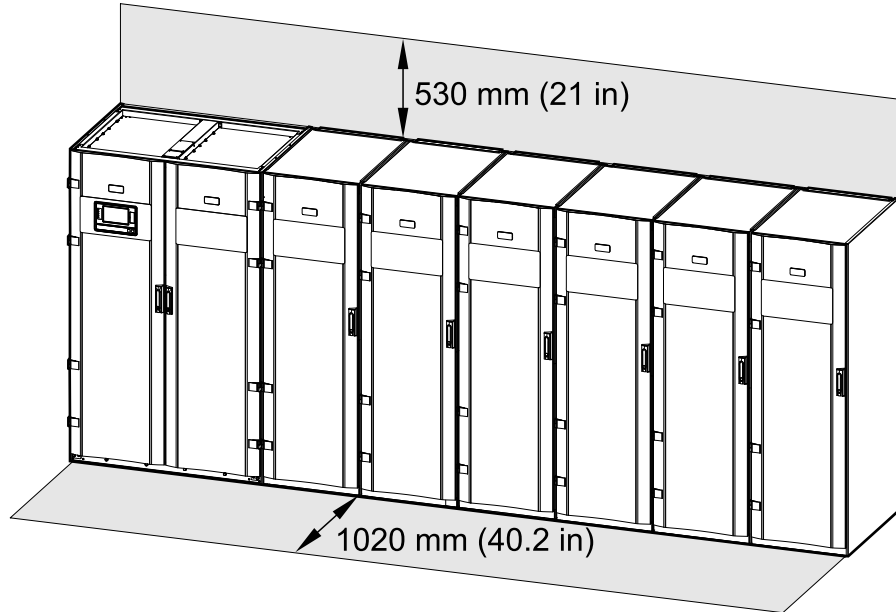

Guidance for Organizing Battery Cables

NOTE: For 3rd party batteries, use only high rate batteries for UPS applications.

NOTE: When the battery bank is placed remotely, the organizing of the cables is important to reduce voltage drop and inductance. The distance between the battery bank and the UPS must not exceed 200 m (656 ft). Contact Schneider Electric for installations with a longer distance.



NOTE: To minimize the risk of electromagnetic radiation, it is highly recommended to follow the below guidance and to use grounded metallic tray supports.

Cable Length				
<30 m	Not recommended	Acceptable	Recommended	Recommended
31–75 m	Not recommended	Not recommended	Acceptable	Recommended
76–150 m	Not recommended	Not recommended	Acceptable	Recommended
151–200 m	Not recommended	Not recommended	Not recommended	Recommended



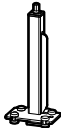

Overview of Supplied Installation Kits

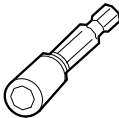

Installation Kits Shipped with the I/O Cabinet

Installation Kit 0M-816661

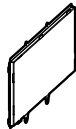
Part	Used in	Number of units
Jack	Follow the receiving and unpacking manual to remove the cabinets from the pallet using this installation kit.	1 
Floor protection plate		1 
Hexagonal socket for drilling machine		1 

Installation Kit 0H-9385





Part	Used in	Number of Units
Angle for right side of the rear anchoring bracket 870-30412	Mount the Rear Anchoring Brackets, page 52	1 
M8 x 20 hexagonal torx with washer		2 
1 mm leveling shims		30 
EMC cover right 0M-98993	Position the Cabinets, page 54	1 
M6 nut with washer		8 
M10 x 45 hexagonal torx with washer	Save for the field service representative. They will be used for fastening the busbars and will be installed by Schneider Electric during assembly service.	16 
M8 x 35 hexagonal torx with washer		2

Part	Used in	Number of Units
		
M10 x 35 bolt with washer		4
Terminator for modbus	Modbus Connections (Board 0P6502), page 86	2 

Installation Kit 0H-9384

Part	Used in	Number of Units
Front anchoring bracket for I/O cabinet	Mount the Front Anchoring Brackets, page 70	1 

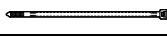
Installation Kit 0H-1789

Part	Used in	Number of Units
Optical fiber cable 0W13010	Route the Signal Cables between the I/O Cabinet and the Power Cabinets, page 71	1 
Optical fiber cable 0W13022		1 
Cable ties for signal cables	Signal Cables, page 71	40 
Temperature sensor 0M-1160	Signal Cable Connections to Classic Battery Cabinets (Boards 0P6547, 0P6549, 0P6552), page 84	2 



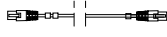
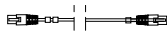





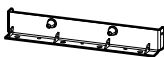

Installation Kit 0H-0889

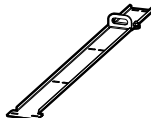



Part	Used in	Number of Units
PBUS 1 cable 0W7995	PBUS Cable Connections (Board 0P3643), page 85	1 
PBUS 2 cable 0W7996		1 

Installation Kits Shipped with the Power Cabinet

Installation Kit 0H-9102

NOTE: These installation kit parts are shipped in the packaging of the power cabinet.

Part	Used in	Number of Units
Rear anchoring bracket for power cabinet 0M-818242	Mount the Rear Anchoring Brackets, page 52	1 
M8 x 20 hexagonal torx with washer		2 
Front anchoring bracket for power cabinet 0M-816684	Mount the Front Anchoring Brackets, page 70	1 
Long top baying bracket 0M-821220	Position the Cabinets, page 54	1 
M6 x 16 torx screw with washer		15 
M10 nut with washer		24 
M10 x 35 hexagonal torx with washer		12 
1 mm leveling shims		10 
Ground interconnection busbar 880-99027		Save for the field service representative. The busbars will be installed by Schneider Electric during assembly service.
M8 nut with washer	4 	
M8 x 35 mm hexagonal torx with washer	4 	
Interconnection busbar 880-10146 and 880-9720 from power cabinet to power cabinet (neutral)	1 	
Interconnection busbar 0M-140035 power cabinet to power cabinet (battery +)	1	

Part	Used in	Number of Units
		
Interconnection busbar 0M-97886 power cabinet to power cabinet (output)		3 
Interconnection busbar 0M-819336 power cabinet to power cabinet (battery -)		1 
Interconnection busbar 0M-97885 power cabinet to power cabinet (input)		3 

Installation Procedure

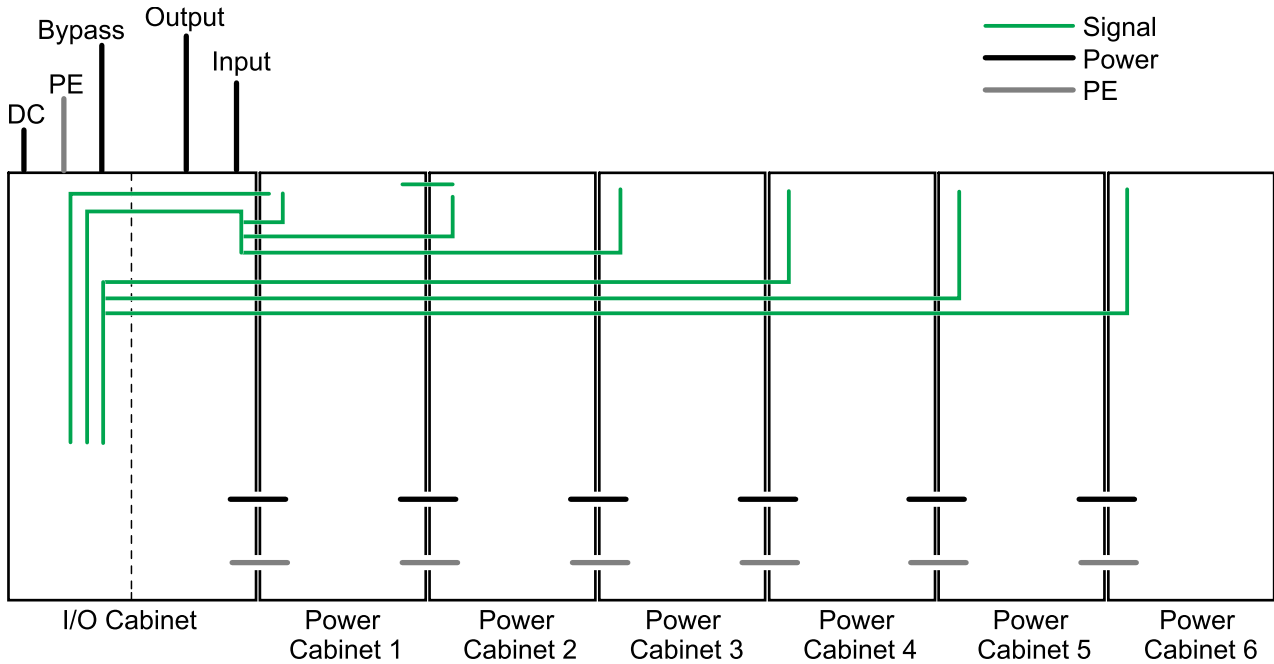

1. Follow the receiving and unpacking manual to remove the cabinets from the pallet.
2. Mount the Rear Anchoring Brackets, page 52.
3. Position the Cabinets, page 54.
4. Prepare the I/O cabinet for power cables. Follow one of the procedures:
 - Prepare the I/O Cabinet for Power Cables in Top Cable Entry Systems, page 60, OR
 - Prepare the I/O Cabinet for Power Cables in Bottom Cable Entry Systems, page 61.
5. For dual mains systems only: Remove the Single Mains Busbars, page 62.
6. Connect the power cables. Follow one of the procedures:
 - Connect the Power Cables in a 380/400/415/440 V System, page 63, OR
 - Connect the Power Cables in a 480 V System, page 66.
7. Connect Cables to the External Supply for Lithium-ion Battery Solution (Optional), page 68.
8. Mount the Front Anchoring Brackets, page 70.
9. Route the Signal Cables between the I/O Cabinet and the Power Cabinets, page 71.
10. Route External Signal Cables to the Boards, page 77.
11. Final Mechanical Assembly, page 95.

For moving or decommissioning the UPS after installation has been completed, see Decommission or Move the UPS to a New Location, page 98.

Mechanical Installation

Mount the Rear Anchoring Brackets

⚠ DANGER

HAZARD OF ELECTRIC SHOCK, EXPLOSION, OR ARC FLASH

Leave the UPS system covered while making anchoring holes to prevent dust or other conductive particles from entering the system.

Failure to follow these instructions will result in death or serious injury.

⚠ WARNING

HAZARD OF TILTING

All rear and front anchoring brackets must be installed.

Failure to follow these instructions can result in death, serious injury, or equipment damage.

1. Use the rear anchoring bracket that was attached to the rear of the I/O cabinet. Fasten the plate from the installation kit 0H-9385 to the right side of the rear anchoring bracket of the I/O cabinet. Note the direction of the plate.

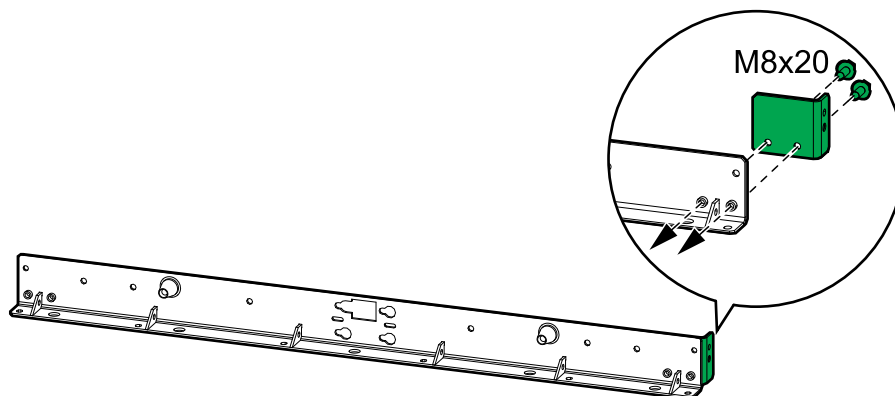

2. Place the rear anchoring brackets for the I/O cabinet and the power cabinets in the final installation area.

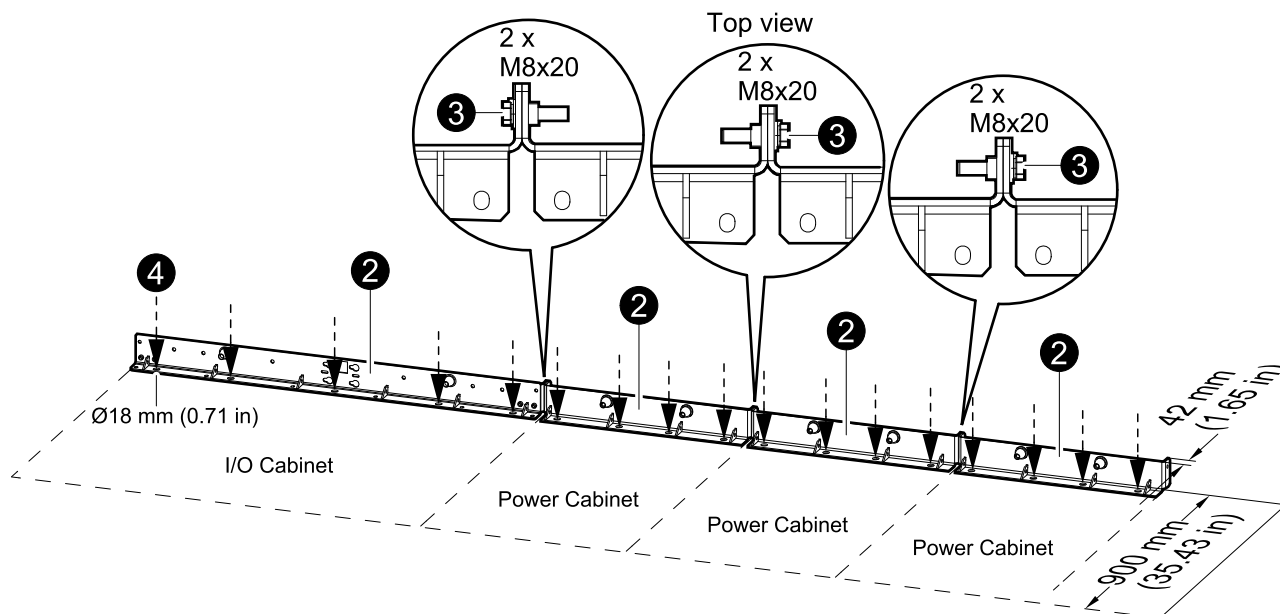

3. Interconnect the rear anchoring brackets using the provided screws and bolts.
4. Mark the hole locations.
5. Drill anchoring holes according to the national and local requirements.
6. Mount the rear anchoring brackets to the floor. Bolts are not supplied.
7. Use a bubble-leveler to ensure that the rear anchoring brackets are level. Use the provided leveling shims if necessary.

Position the Cabinets

⚡⚠ DANGER

HAZARD OF ELECTRIC SHOCK, EXPLOSION, OR ARC FLASH

Do not step/walk on top of the cabinets.

Failure to follow these instructions will result in death or serious injury.

1. Install the cover from installation kit 0M-98993 on the right-most power cabinet.

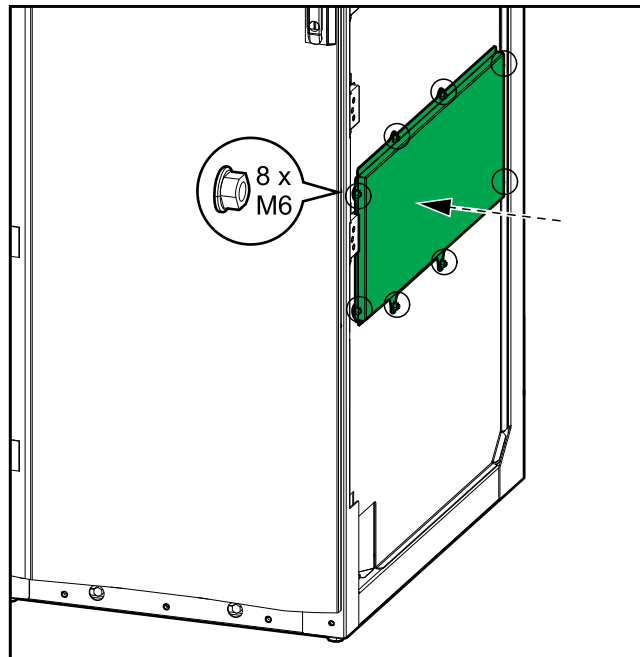

2. Move the side panel from the right side of the I/O cabinet and install it on the right-most power cabinet.

⚠️ ⚠️ WARNING

HAZARD OF ARC FLASH

- Do not make mechanical changes to the product (including removal of cabinet parts or drilling/cutting of holes) that are not described in the installation manual.
- Move and install the indicated side panel in all installation types (including parallel installations with no air gap between the frames or in installations where the right-most power cabinet is placed against a wall).

Failure to follow these instructions can result in death, serious injury, or equipment damage.

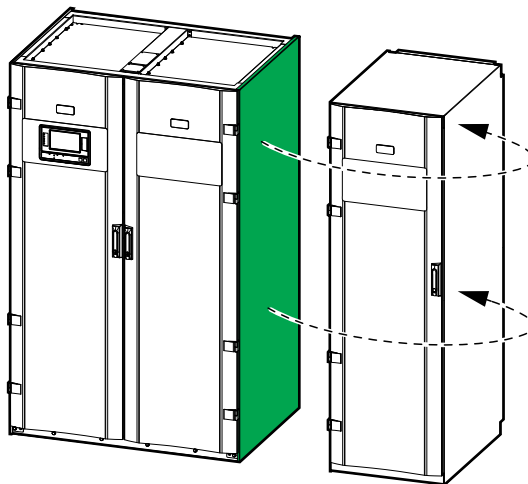

3. Open the two inner doors of the I/O cabinet.

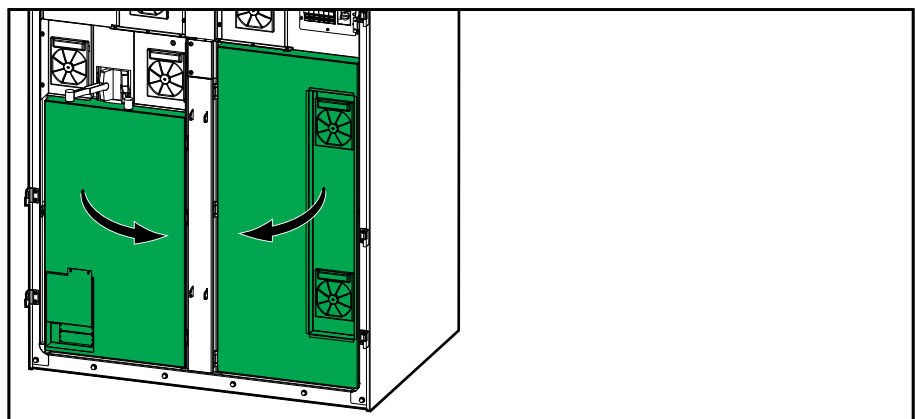

4. Remove the two rear bottom plates.

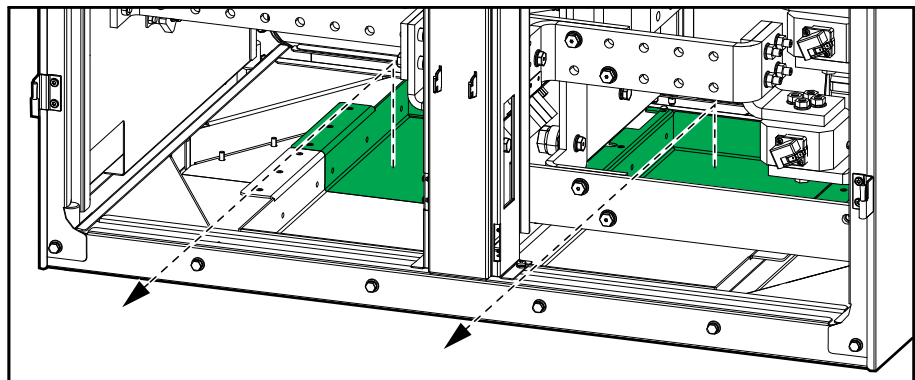

5. Push the I/O cabinet into position against the rear anchoring bracket - the I/O cabinet will connect to the conic outcroppings on the rear anchoring bracket.

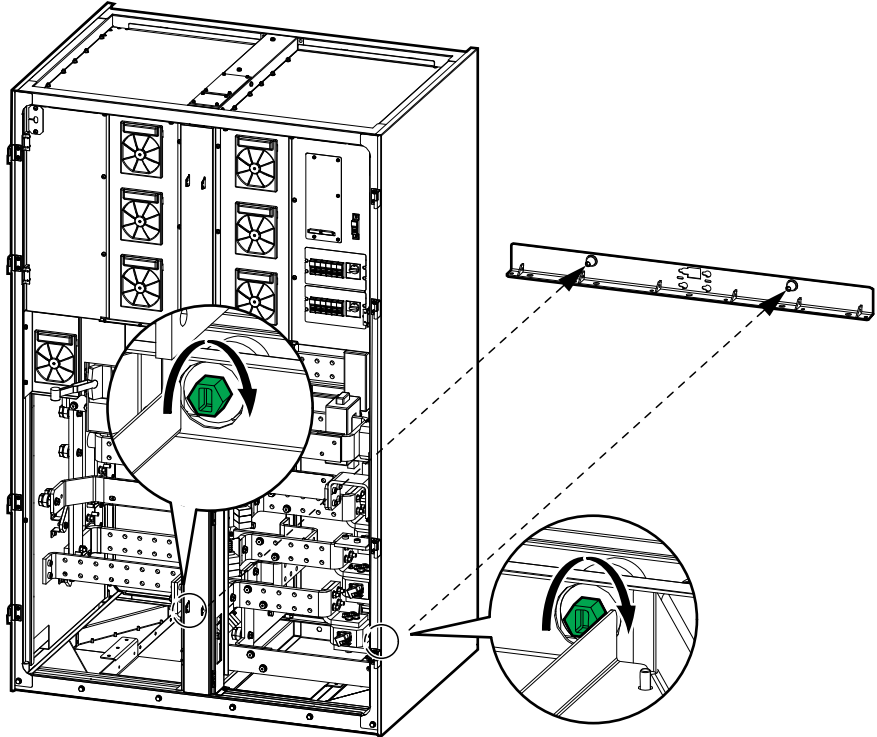

6. Fasten the cabinet to the rear anchoring bracket by tightening the bolts. Torque to 50 Nm (36.87 lb-ft).
7. Reinstall the two rear bottom plates.
8. Push the power cabinets one by one into position against the rear anchoring brackets – the cabinets will connect to the conic outcroppings on the brackets.

▲ CAUTION

RISK OF EQUIPMENT DAMAGE

When pushing the power cabinet into position, push on the frame to avoid damaging the signal cables.

Failure to follow these instructions can result in injury or equipment damage.

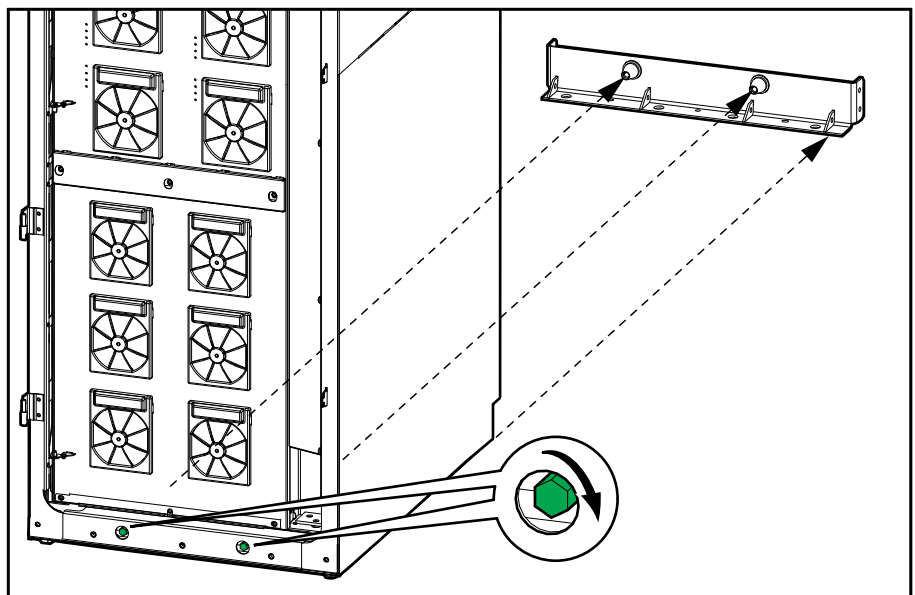

9. Fasten the power cabinets to the rear anchoring brackets by tightening the bolts on the front of the power cabinet. Torque to 50 Nm (36.87 lb-ft).
10. Lower the two front feet on all cabinets until they connect with the floor – use a bubble-leveler to ensure that the cabinets are level. Use the provided levelling shims if necessary.
11. Install the top baying bracket on the top of the cabinets and fasten with the provided screws.

I/O Cabinet and Two Power Cabinets

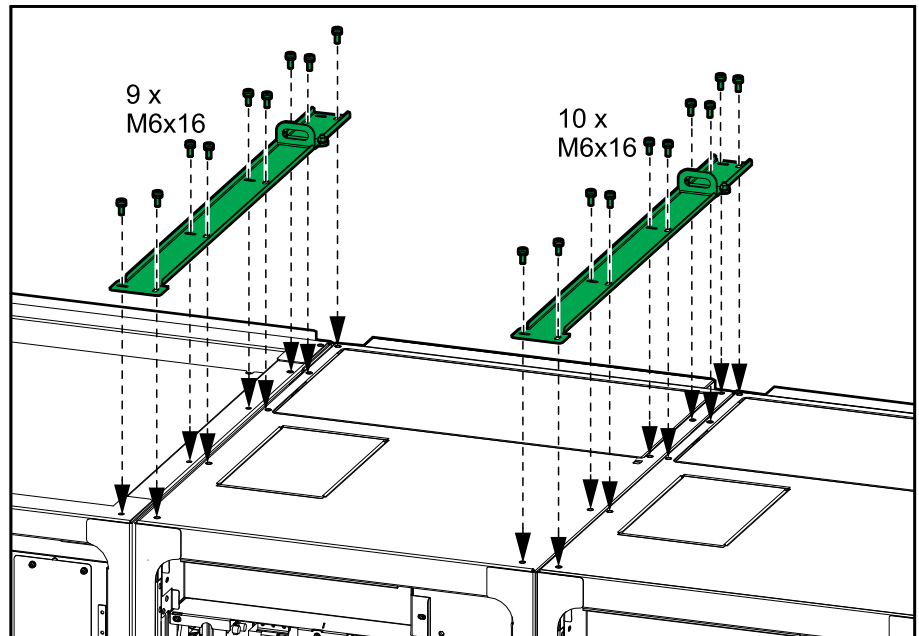

12. Mount the M6 screws from the installation kit from right to left in the five marked positions between the power cabinets and in the four marked positions between the power cabinet and the I/O cabinet to interconnect the cabinets.

From Power to Power Cabinet

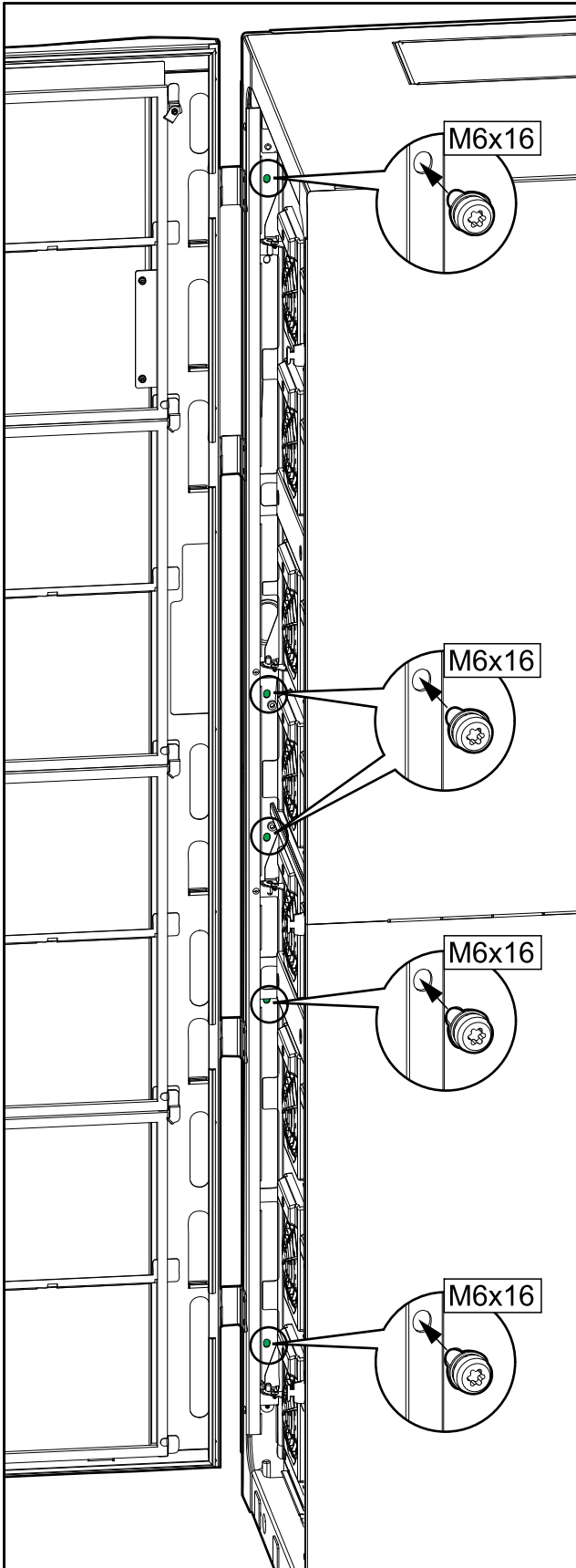

From Power to I/O Cabinet

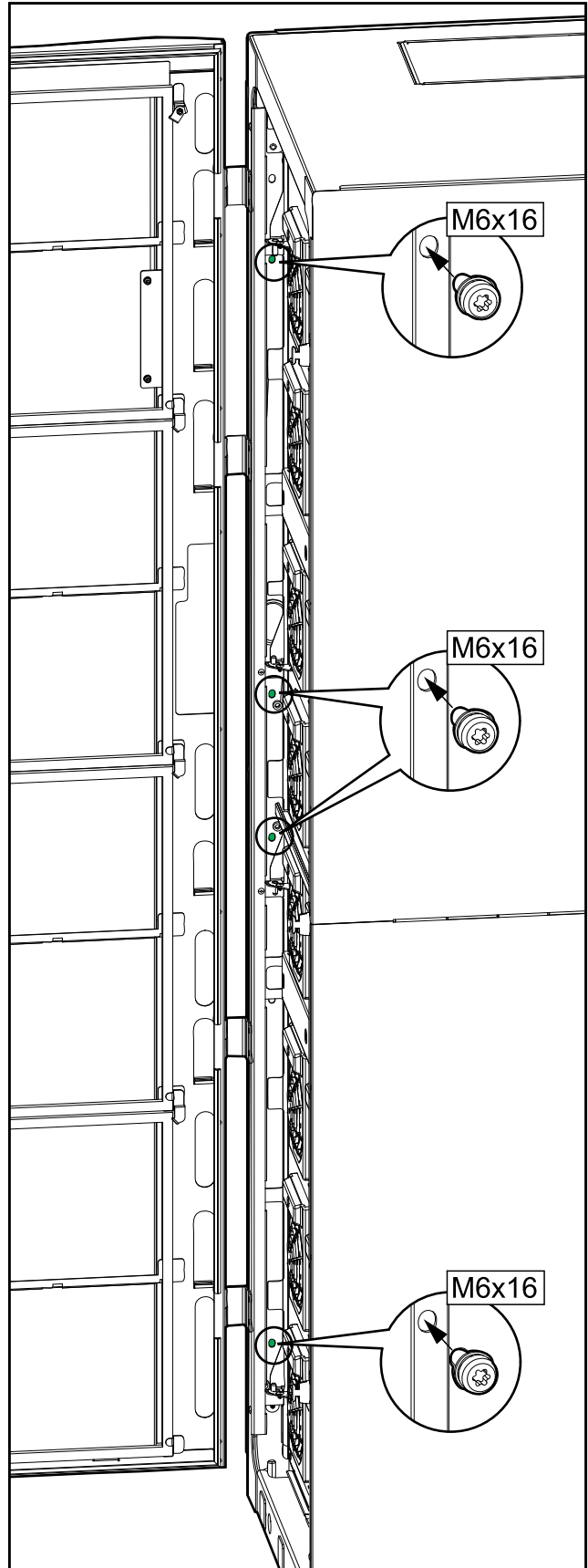

13. Verify that the right-most power cabinet for the I/O cabinet has the cover 0M-98993 and the side panel installed before continuing.

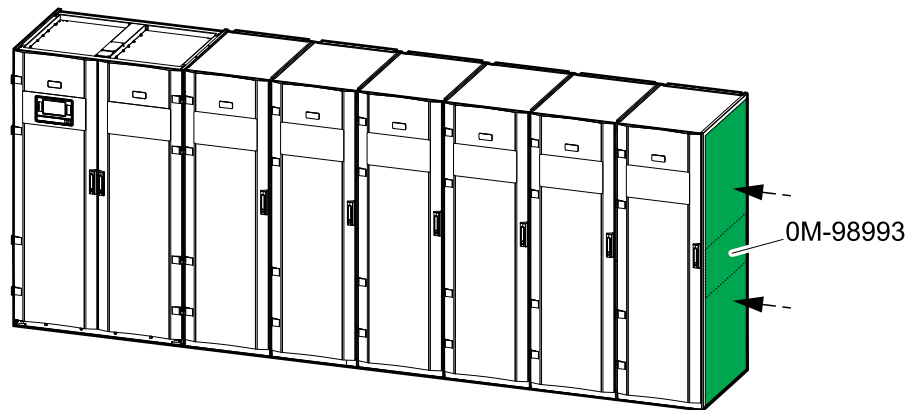
1250 kW I/O with Maximum Number of Power Cabinets

Connect the Power Cables

Prepare the I/O Cabinet for Power Cables in Top Cable Entry Systems

⚠ DANGER

HAZARD OF ELECTRIC SHOCK, EXPLOSION, OR ARC FLASH

Do not drill/punch holes for cables or conduits with the gland plates installed and do not drill/punch holes in close proximity to the UPS.

Failure to follow these instructions will result in death or serious injury.

1. Loosen the bolts and remove the gland plates from the top of the I/O cabinet.

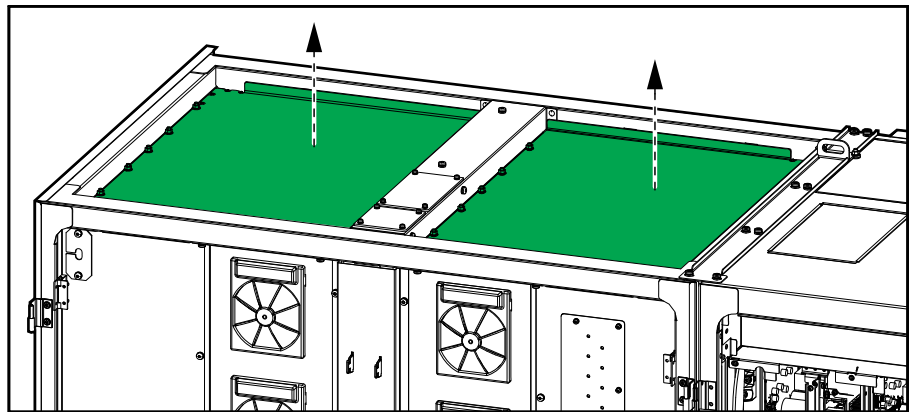

2. Drill or cut holes for cables/conduits in the top gland plate.

⚠ DANGER

HAZARD OF ELECTRIC SHOCK, EXPLOSION, OR ARC FLASH

Ensure that there are no sharp edges that can damage the cables.

Failure to follow these instructions will result in death or serious injury.

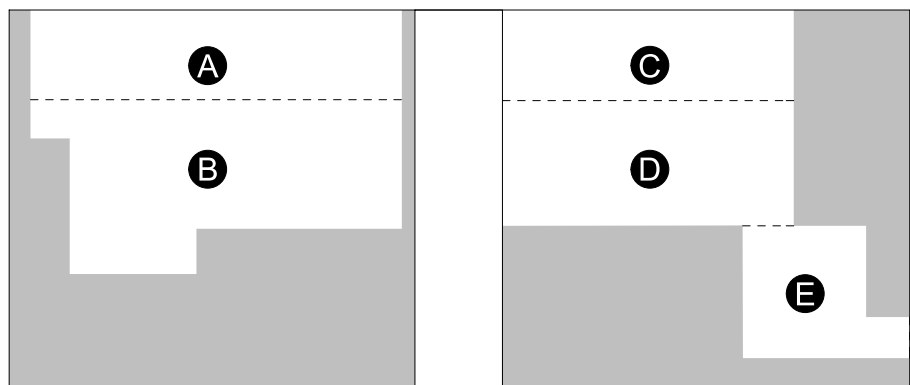

- A. For bypass cables
- B. For DC cables
- C. For output cables
- D. For input cables
- E. For cables to the external supply for Li-Ion

3. Install conduits and reinstall the top gland plate.

Prepare the I/O Cabinet for Power Cables in Bottom Cable Entry Systems

⚠ DANGER

HAZARD OF ELECTRIC SHOCK, EXPLOSION, OR ARC FLASH

Do not drill/punch holes for cables or conduits with the gland plates installed and do not drill/punch holes in close proximity to the UPS.

Failure to follow these instructions will result in death or serious injury.

NOTE: Cables to the external supply for Lithium-ion battery solution must be routed through the top of the I/O cabinet. Follow the procedure *Prepare the I/O Cabinet for Power Cables in Top Cable Entry Systems*, page 60 to prepare for cables to the external supply.

NOTE: You may need to elevate the cabinet by lowering the cabinet feet or reduce the floor height directly beneath the bottom gland plates to get correct wire bending range for the power cables.

1. Loosen the bolts and remove the gland plates in the bottom of the I/O cabinet.

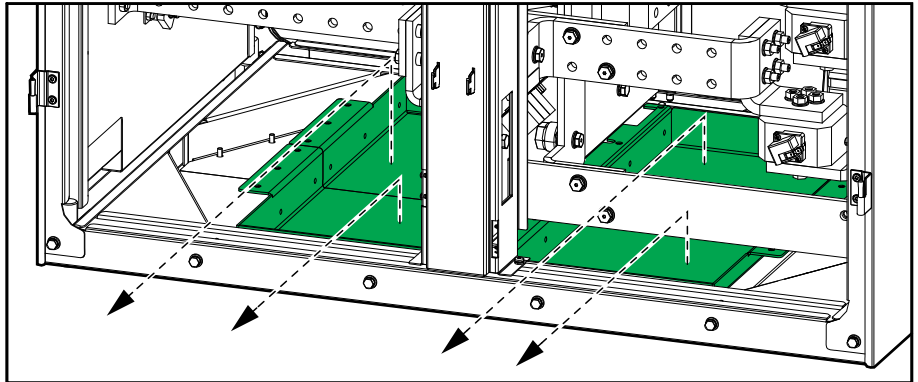

2. Drill or cut holes for cables/conduits in the bottom gland plate.

⚠ DANGER

HAZARD OF ELECTRIC SHOCK, EXPLOSION, OR ARC FLASH

Ensure that there are no sharp edges that can damage the cables.

Failure to follow these instructions will result in death or serious injury.

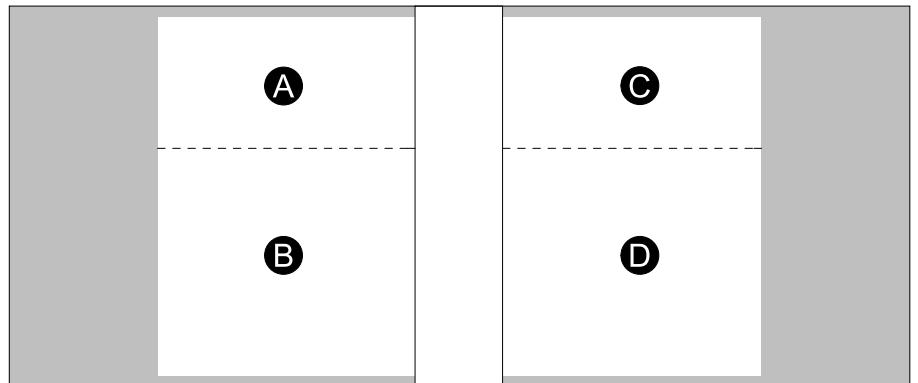

- A. For bypass cables
- B. For DC cables
- C. For output cables
- D. For input cables

3. Install conduits and install the bottom gland plates in the indicated order below the frame.

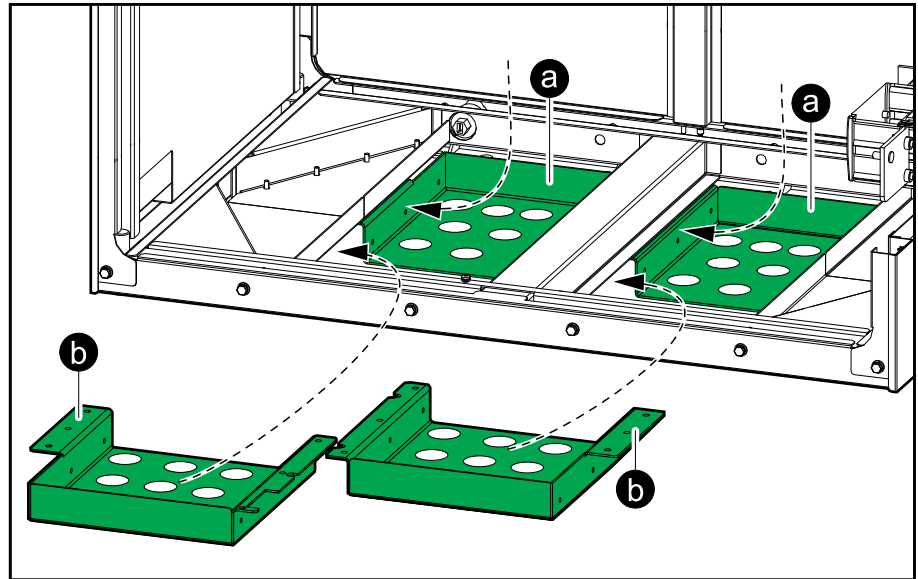

Remove the Single Mains Busbars

NOTE: This procedure is only applicable to dual mains systems.

1. Remove the three single mains busbars.

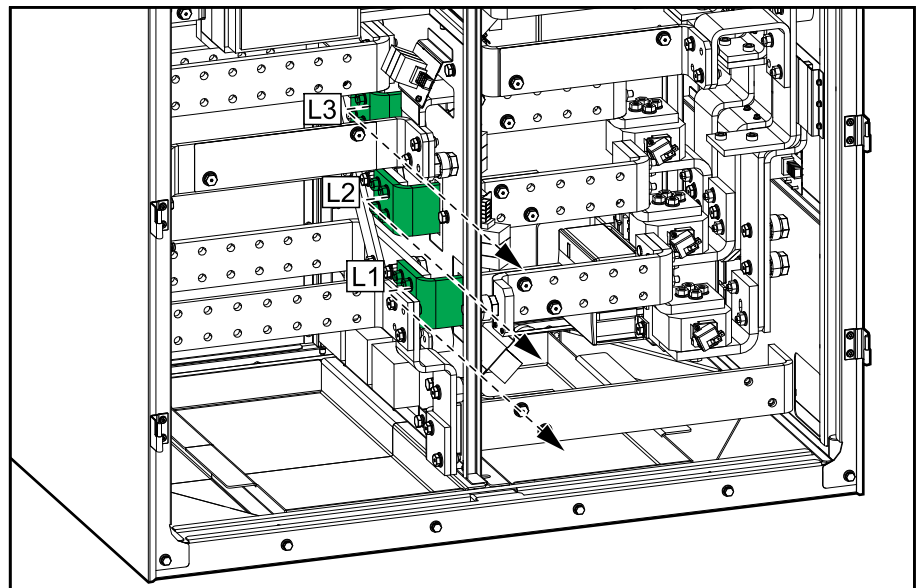

Connect the Power Cables in a 380/400/415/440 V System

1. Only applicable to installations with neutral connection: Remove the lexan plate from the N busbars.

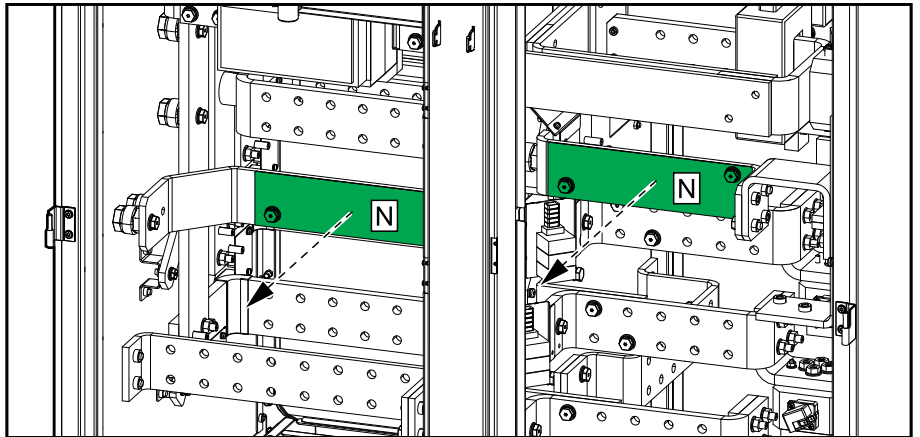

2. Only applicable to TNC systems:

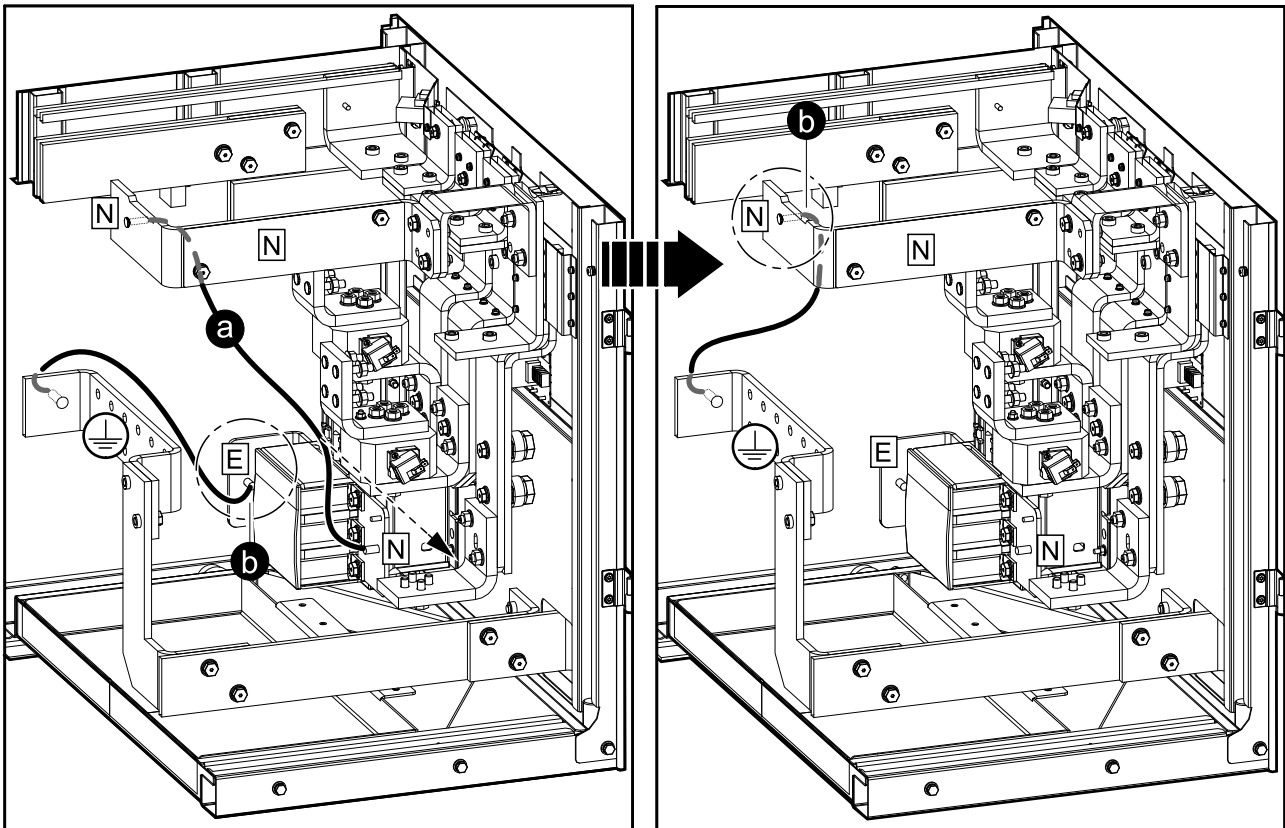

- a. Remove the jumper cable between the N terminal on the bonding contactor and the N busbar.
- b. Disconnect the jumper cable from the E terminal on the bonding contactor and connect to the N busbar.

3. Only applicable to 4-wire IT systems:

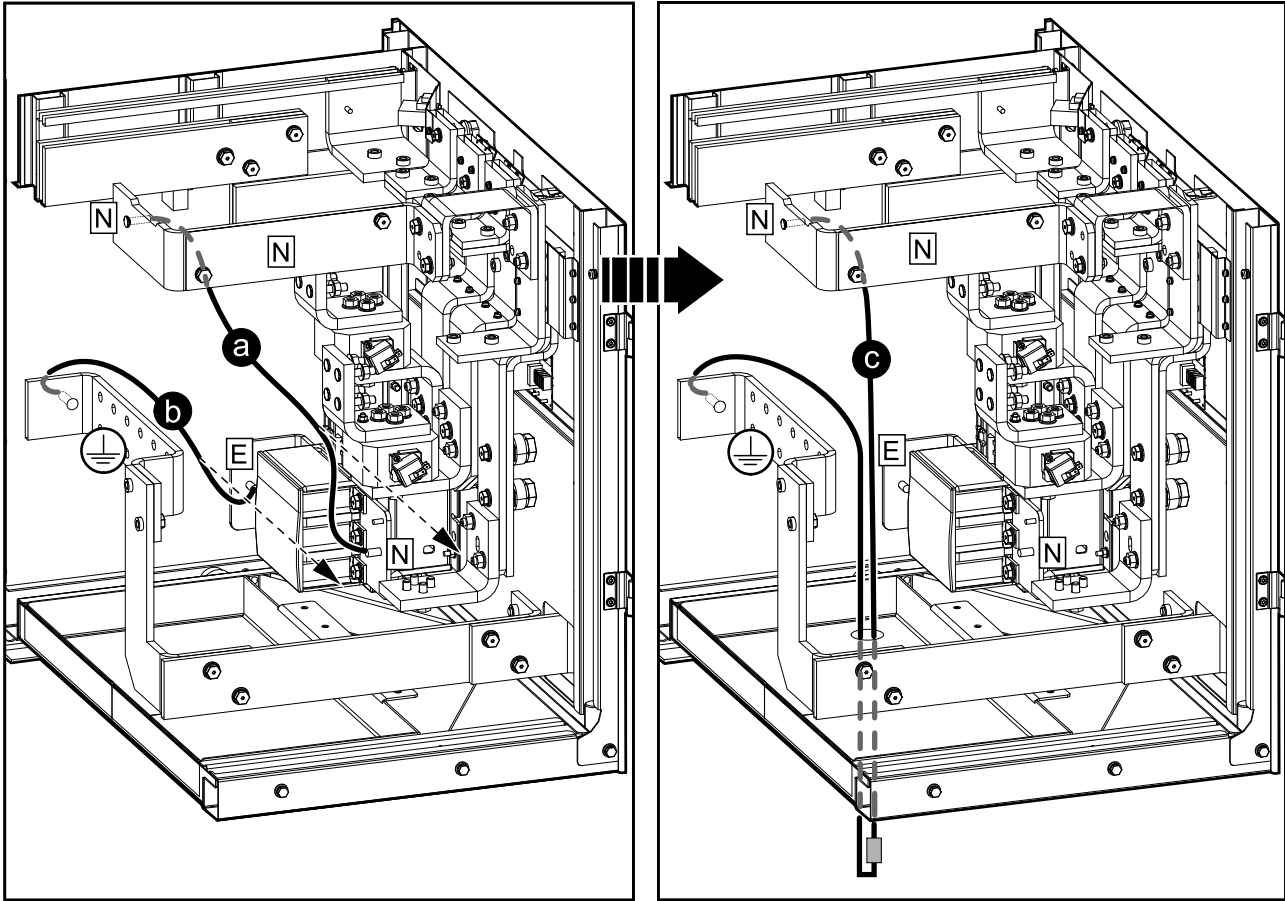

- a. Remove the jumper cable between the N terminal on the bonding contactor and the N busbar.
- b. Remove the jumper cable between the E terminal and the PE busbar.
- c. Connect an external impedance between the PE busbar and the N busbar.

4. Connect the equipment earthing conductor/PE to the PE busbar.

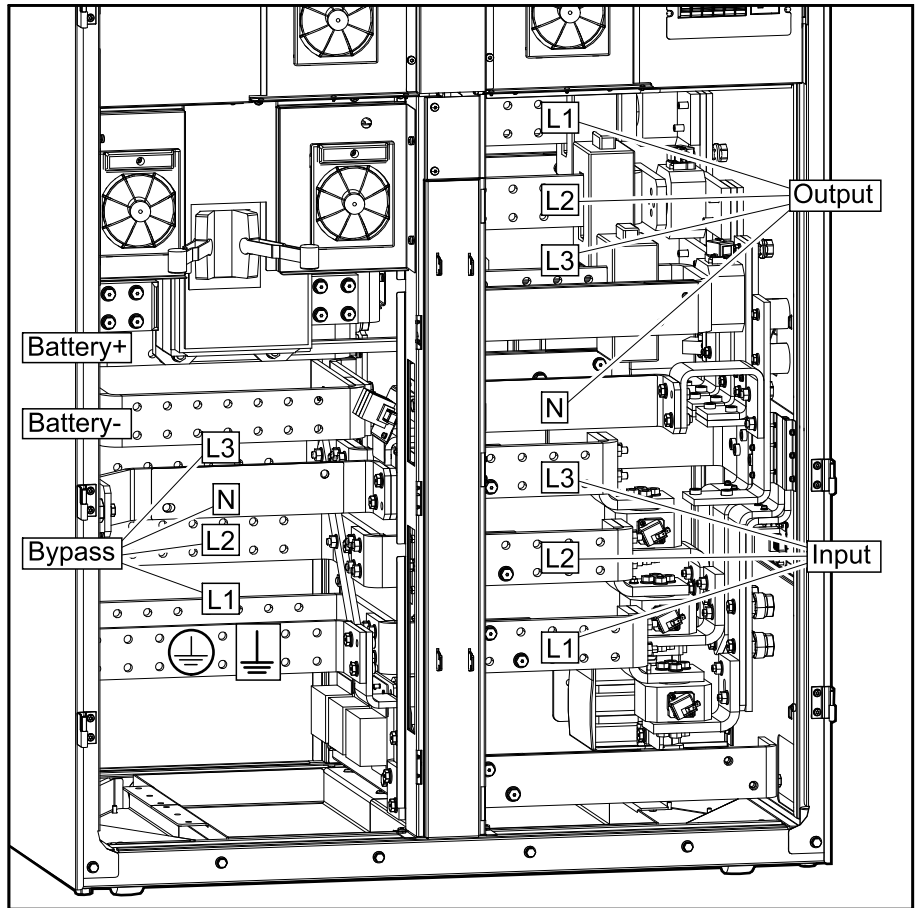

5. Connect the input cables.
6. Only applicable to dual mains systems: Connect the bypass cables.
7. Connect the output cables.
8. Connect the DC cables to the battery+ and battery- busbars.
9. **For systems without internal backfeed breaker BF2:** Fasten the provided plastic fasteners on the bypass cables in four places at 30 cm intervals. Adjust the fasteners to the bypass cables so they are fitted tightly together.
10. **For systems without internal backfeed breaker BF2:** Fasten the provided plastic fasteners on the output cables in two places at 30 cm intervals. Adjust the fasteners to the output cables so they are fitted tightly together.

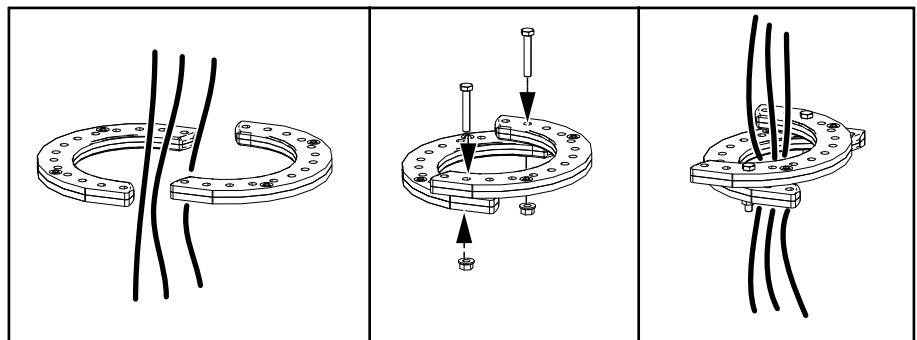

Connect the Power Cables in a 480 V System

For 4-wire systems:

- Bonding jumper: Not connected
- Technical/system earth: No local grounding electrode connected

For 3-wire systems:

- Bonding jumper: Must be connected
- Technical/system earth: A grounding electrode must be connected via the grounding electrode conductor.

1. Only applicable to high impedance grounding systems:

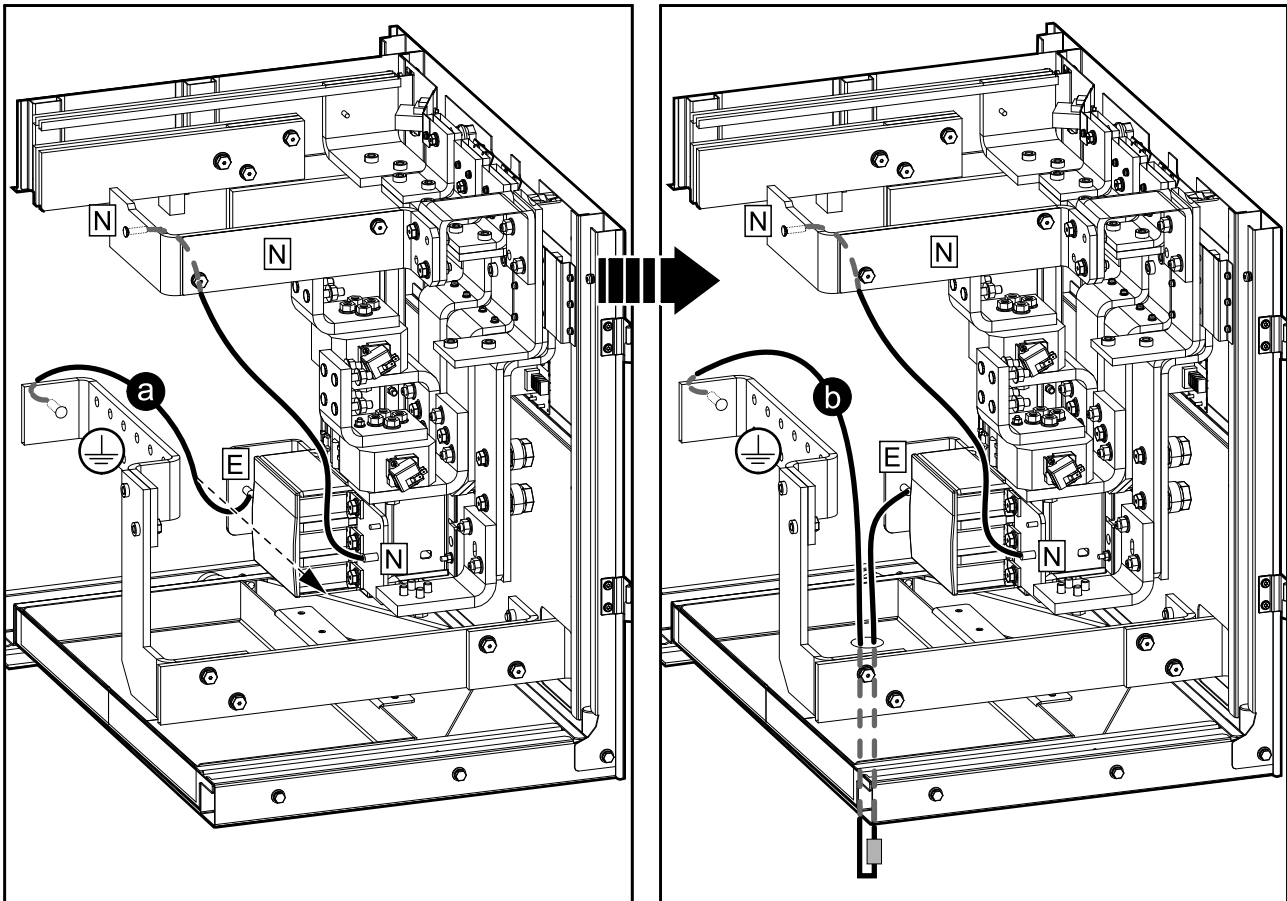

- a. Remove the jumper cable between the PE busbar and the E terminal.
- b. Connect an external impedance between the PE busbar and E terminal according to NEC 2014 article 250.36.

2. Connect the equipment grounding conductor/PE to the PE busbar.

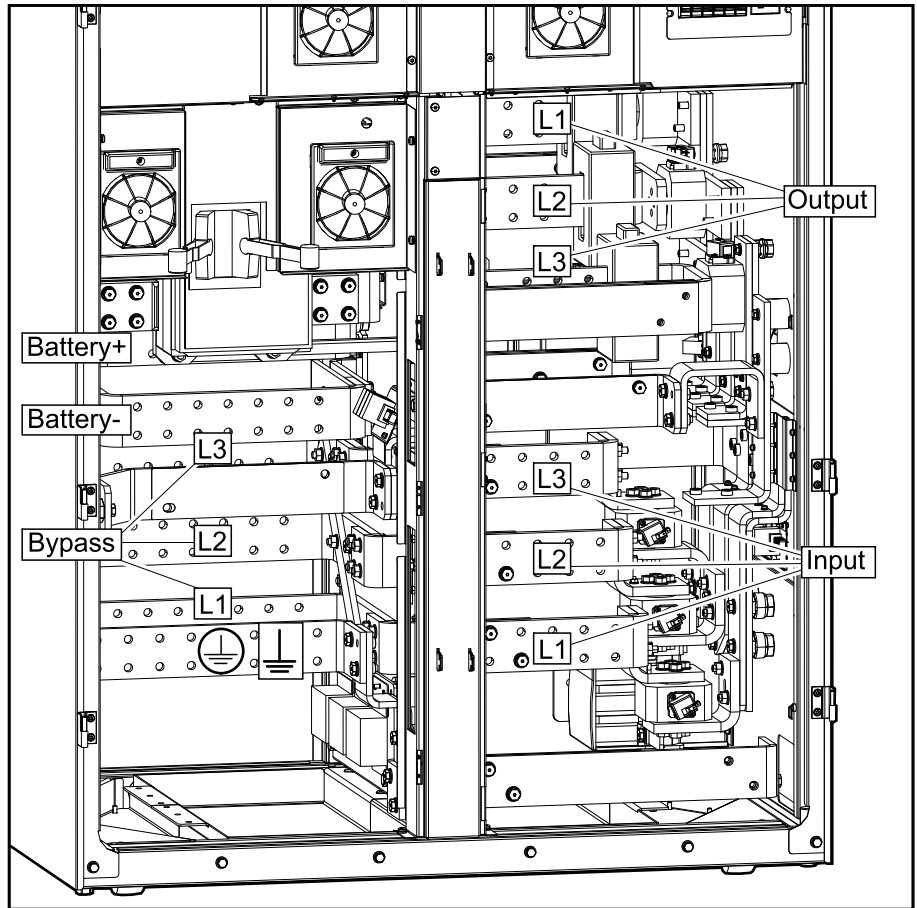

3. Connect the input cables.
4. Only applicable to dual mains systems: Connect the bypass cables.
5. Connect the output cables.
6. Connect the DC cables to the battery+ and battery- busbars.
7. **For systems without internal backfeed breaker BF2:** Fasten the provided plastic fasteners on the bypass cables in four places at 30 cm intervals. Adjust the fasteners to the bypass cables so they are fitted tightly together.
8. **For systems without internal backfeed breaker BF2:** Fasten the provided plastic fasteners on the output cables in two places at 30 cm intervals. Adjust the fasteners to the output cables so they are fitted tightly together.

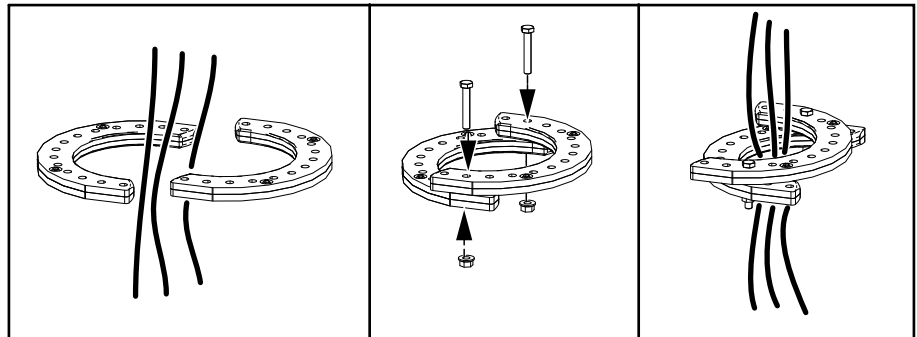

Connect Cables to the External Supply for Lithium-ion Battery Solution (Optional)

Depending on your chosen configuration, the 1250 kW I/O cabinet may not have the battery control breakers preinstalled. If needed, the Galaxy VX Lithium-ion BMS Power Supply Kit (GVXOPT002) can be ordered and installed on site.

⚠ DANGER

HAZARD OF ELECTRIC SHOCK, EXPLOSION, OR ARC FLASH

Do not drill/punch holes for cables or conduits with the gland plates installed and do not drill/punch holes in close proximity to the UPS.

Failure to follow these instructions will result in death or serious injury.

The rating of the external supply breaker is 6.3 A.

Cable Sizes for External Supply

	Conductors per Phase	PE Conductor/Equipment Grounding Conductor	Conduit
Cable sizes for 400 V systems	1.5 mm ²	1.5 mm ²	NA
Cable sizes for 480 V systems ⁸²	1x12-18 AWG	1x18 AWG	0.5 in

1. Follow the procedure Prepare the I/O Cabinet for Power Cables in Top Cable Entry Systems, page 60 to prepare the top gland plate for cables.
2. Open the indicated door and remove the covers in front of the battery control breakers.

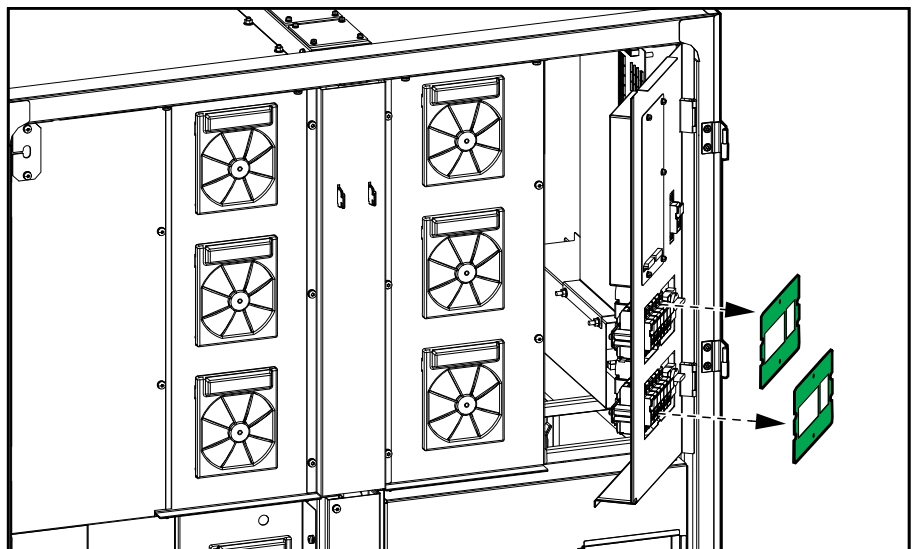

82. An external branch circuitry protection in accordance with the National Electric code NFPA 70 shall be provided externally if required by local regulations.

3. Connect the cables from the equipment to be supplied by the UPS.

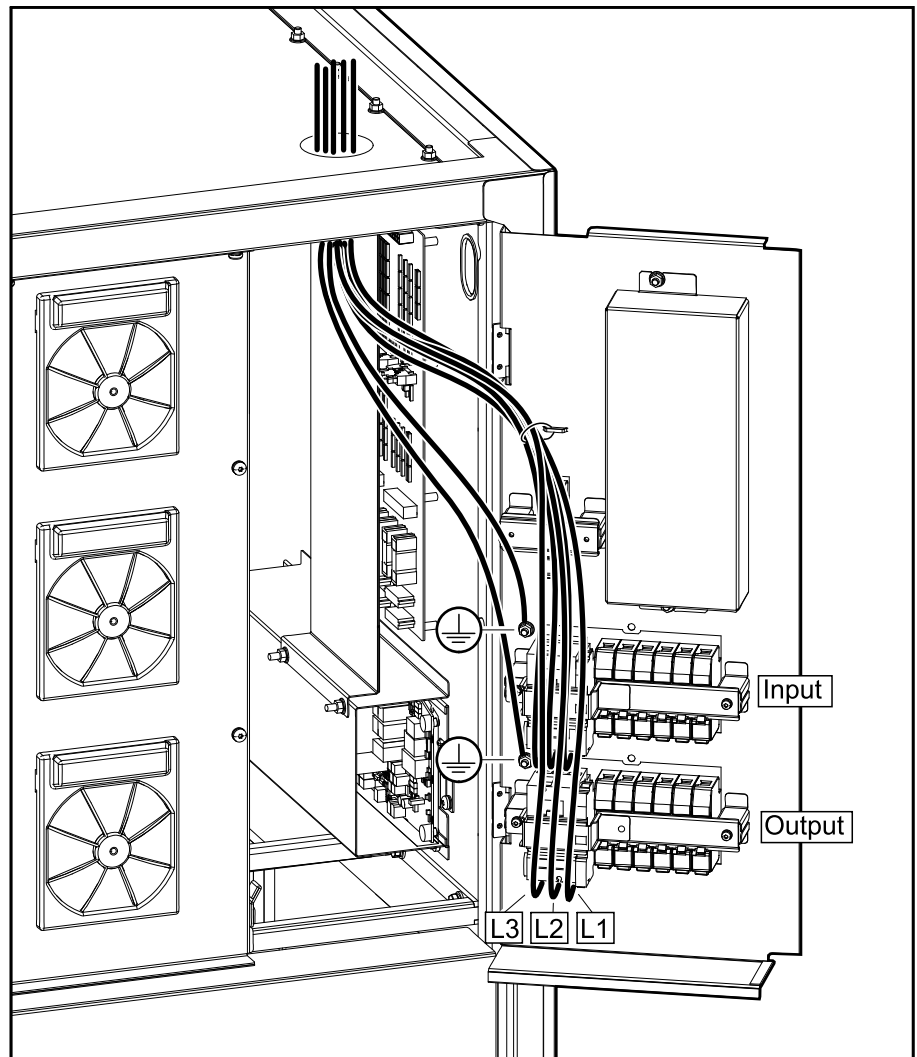

4. Reinstall the covers in front of the battery control breakers.
5. Close the door.

Mount the Front Anchoring Brackets

1. Fasten the front anchoring brackets to the front of the cabinets using the provided bolts.

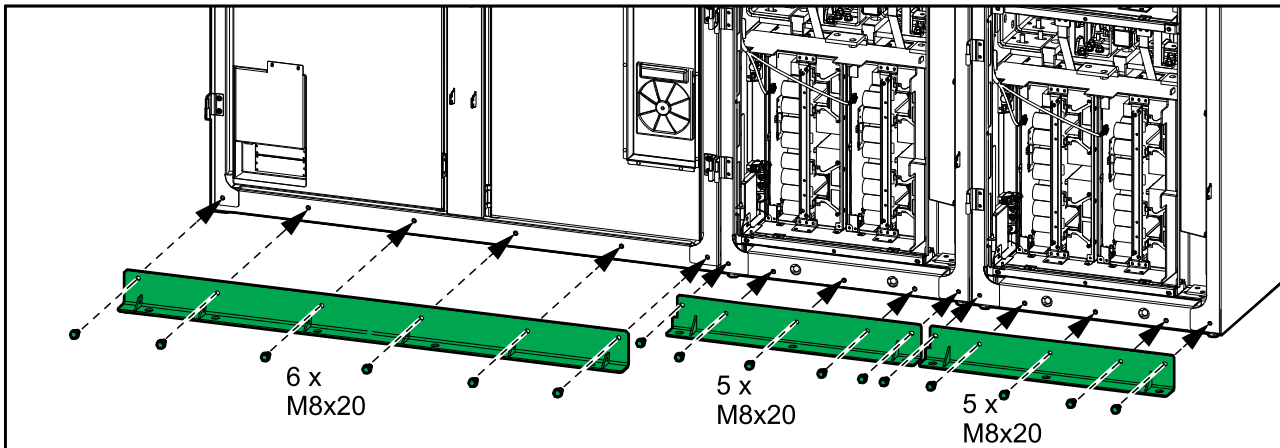

2. Anchor the front anchoring brackets to the floor.

NOTE: Floor anchoring bolts are not supplied.

Signal Cables

⚠ CAUTION

RISK OF EQUIPMENT DAMAGE

- All Class 2/SELV signal cables shall be double insulated/jacket cable and minimum rated for 30 VDC. All non-Class 2/non-SELV signal cables shall be double insulated/jacket cable and minimum rated for 600 VAC.
- The cable supplying the shunt trip shall be a jacket cable and rated for 600 VAC. The cables shall be sized taking the cable voltage drop and the recommendation of the shunt trip manufacturer into consideration.

Failure to follow these instructions can result in injury or equipment damage.

Route the Signal Cables between the I/O Cabinet and the Power Cabinets

NOTE: Do not connect the signal cables. Signal cables will be connected by Schneider Electric during the assembly service.

Overview of Signal Cables between the I/O Cabinet and the Power Cabinets

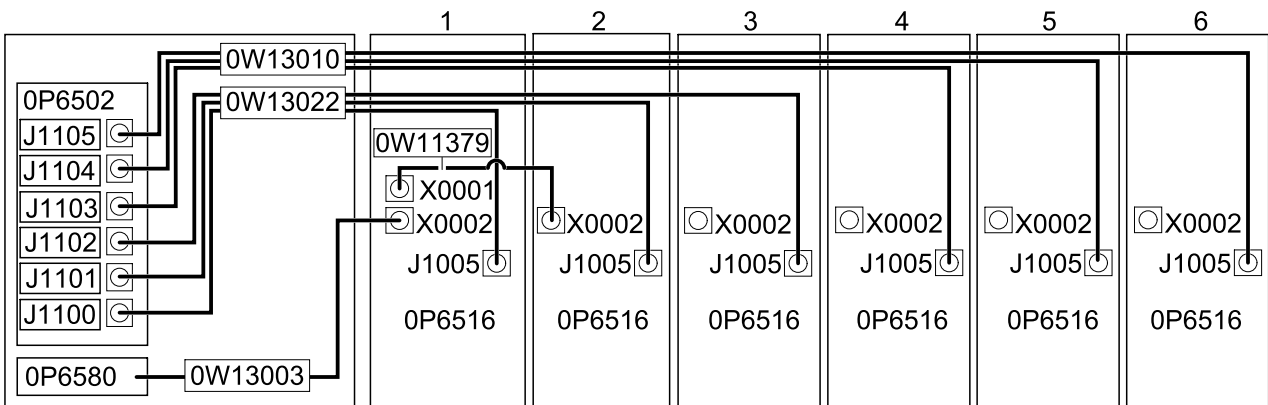

1. Remove the indicated plates from the I/O cabinet and all the power cabinets.

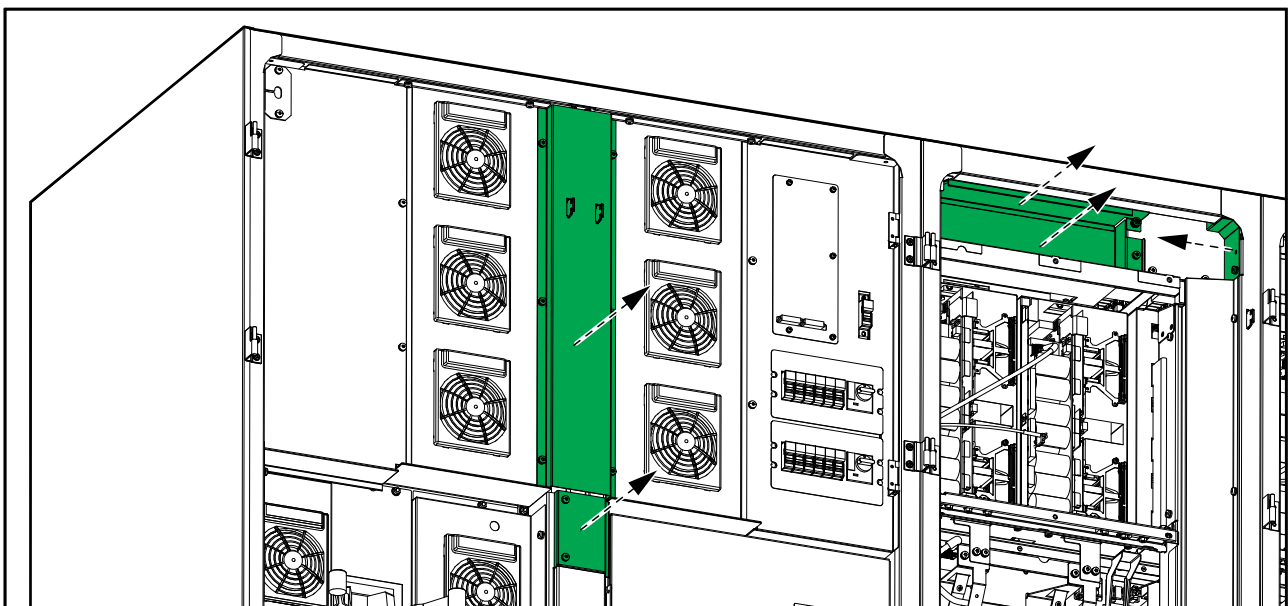

2. Route signal cable 0W11379 from X0002 in the power cabinet 2 to X0001 in power cabinet 1.

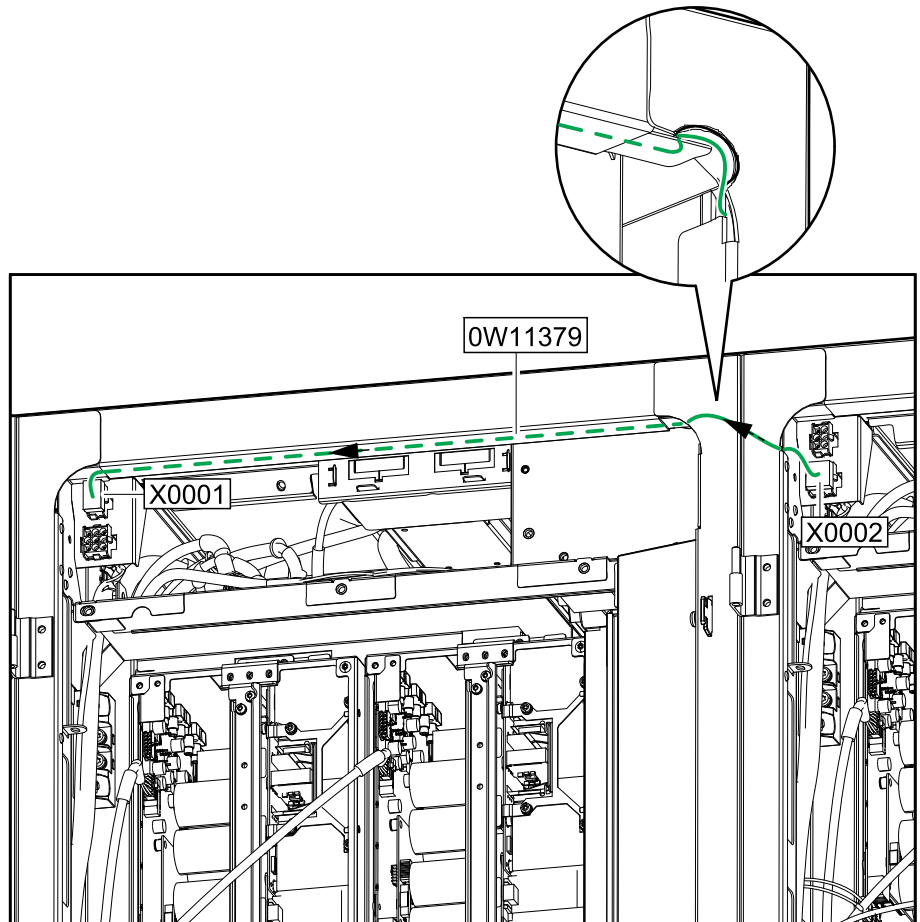

3. Route the signal cable 0W13003 preconnected in the right side of the I/O cabinet to X0002 in power cabinet 1.

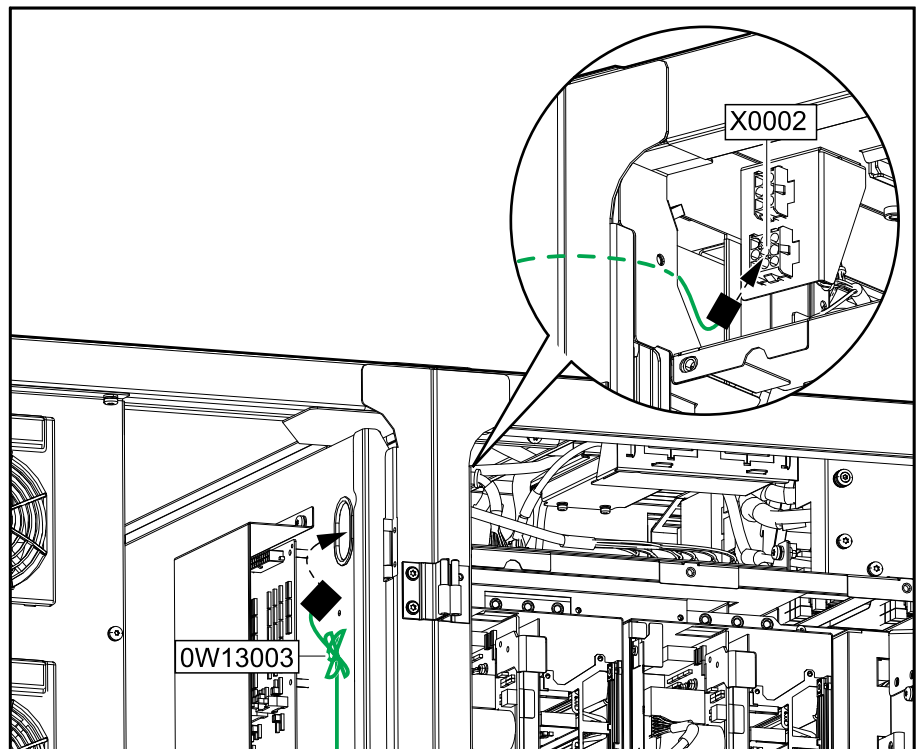

4. Open the left inner door and remove the indicated plate from the door.

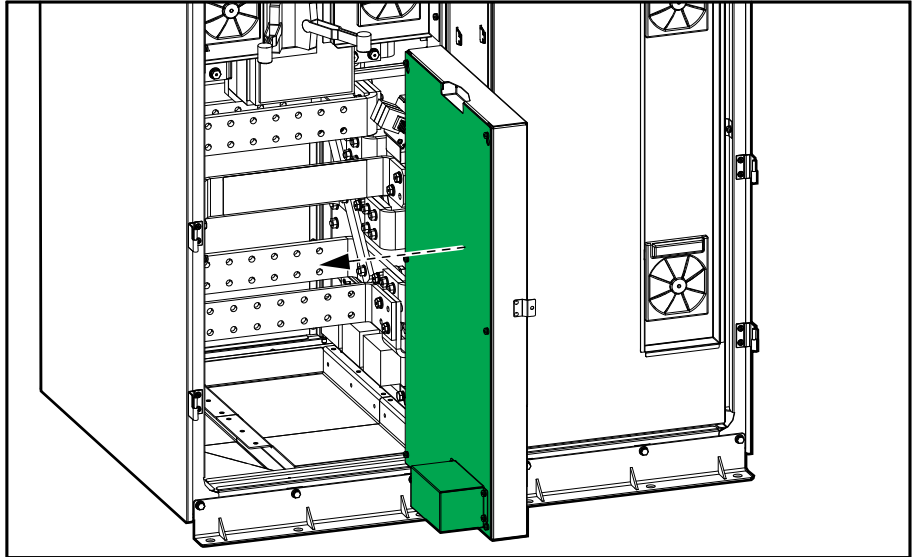

5. Route the signal cables 0W13022 (power cabinets 1-3) and 0W13010 (power cabinets 4-6) from the J1005 terminals in the power cabinets to the I/O cabinet.

NOTE: Minimum bending radius is 50 mm.

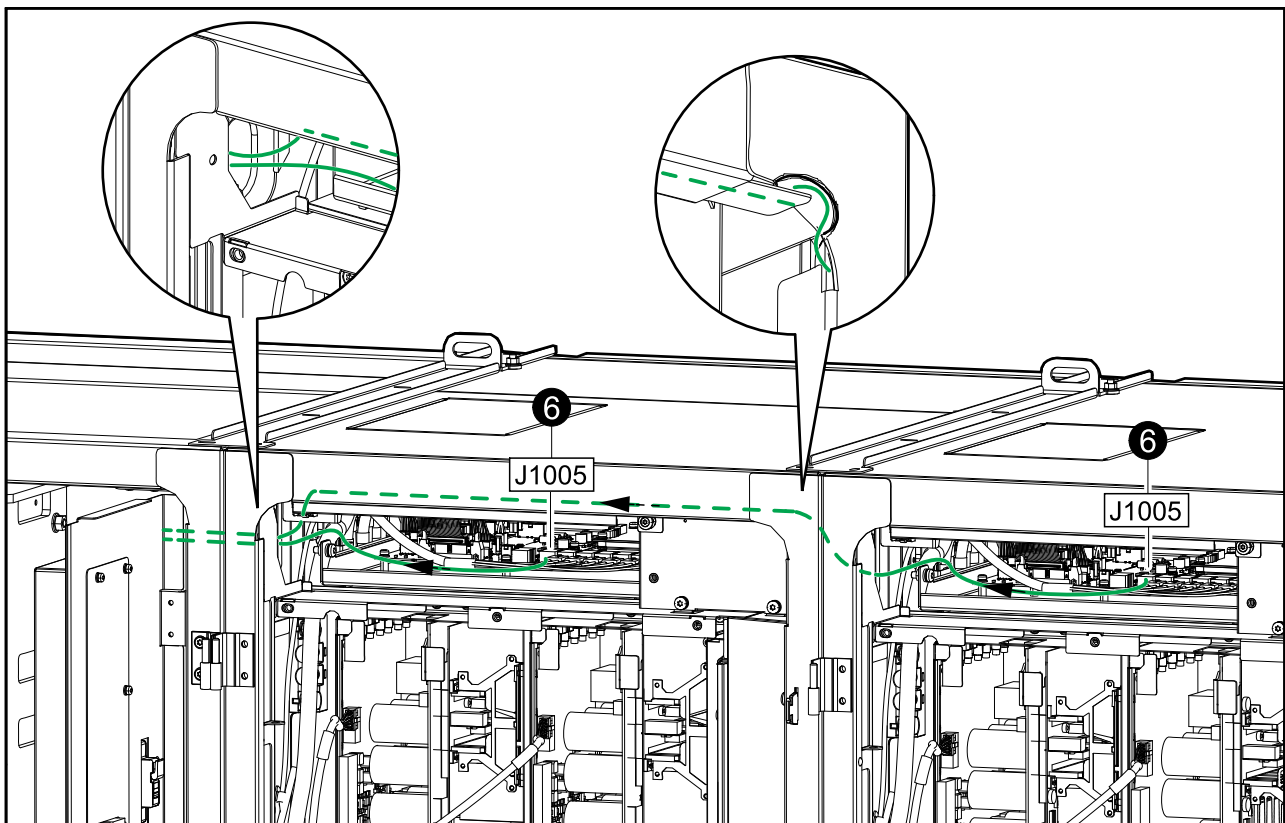

6. Route the signal cables 0W13022 and 0W13010 to the board 0P6502 in the left door.

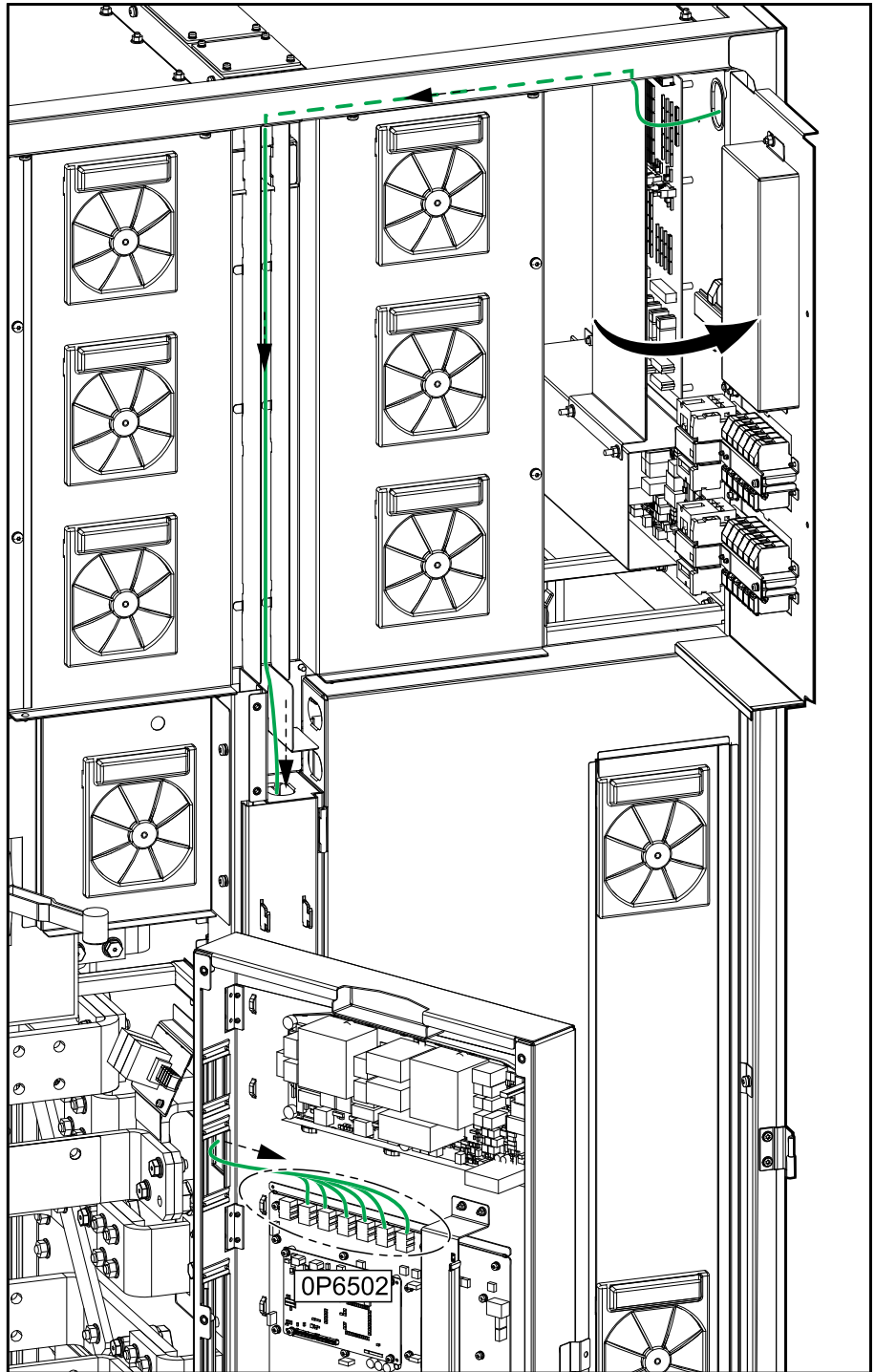

Overview of Board Locations for External Signal Cables

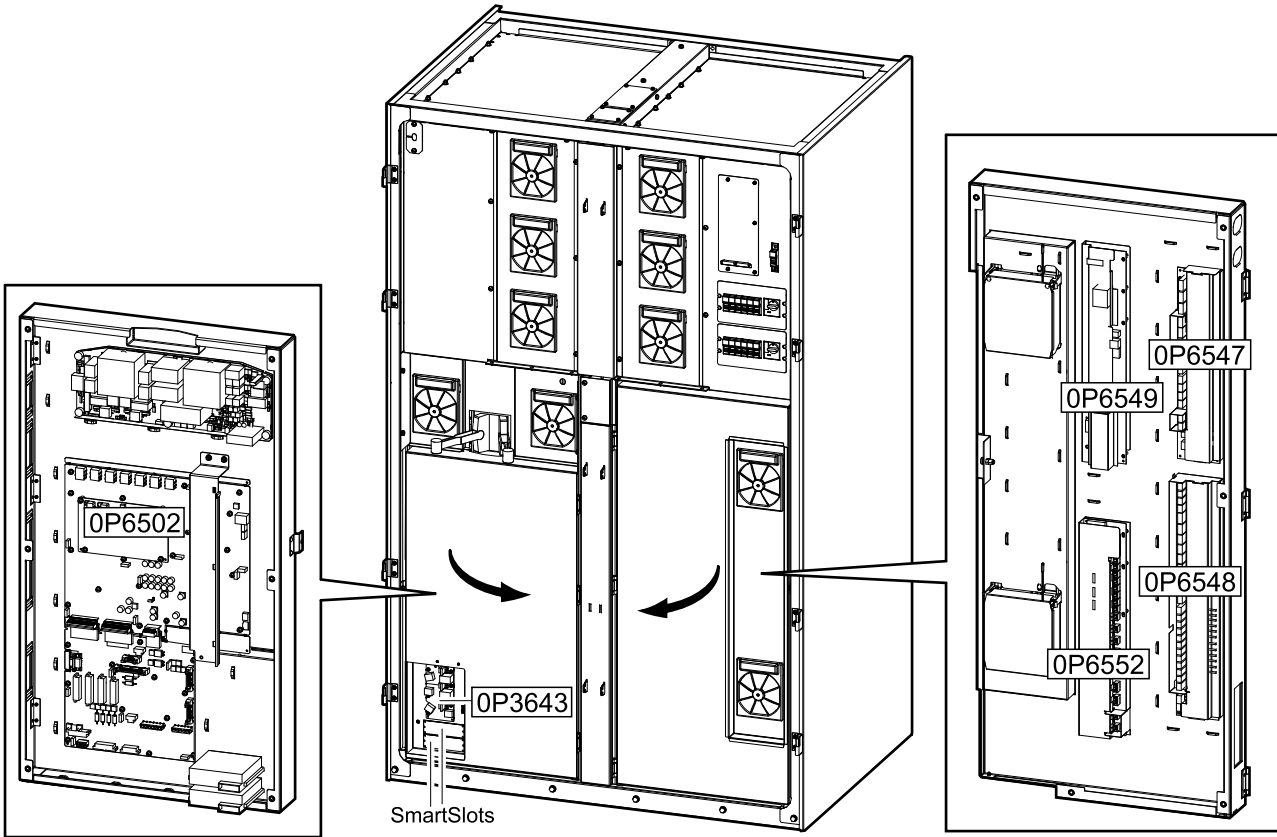

Follow the procedure [Route External Signal Cables to the Boards](#), page 77 to route the external signal cables to the boards.

Class 2/SELV

Board	Terminal	Description	See
0P6547	J4931, J4932	+24V SELV	Connect the Emergency Power Off (EPO), page 88
	J4936-J4938	EPO connections	
0P6548	J5502-J5505, J5510	Input contacts IN1-IN5	Overview of Input Contacts and Output Relays, page 81
	J5506	Input contact IN9	
	J5520-J5525, J5528	Output relays OUT8,9,10	
	J5527	Kirk key control	Signal Cable Connections to the Switchgear (Boards 0P6547, 0P6548, 0P6549), page 83
	J5514	UOB lamp control	
	J5515	MBB lamp control	
	J5516	SIB lamp control	
	J5517	SSIB lamp control	
	J5509	Redundant UOB AUX	
0P3643	PBUS1, PBUS2	PBUS	PBUS Cable Connections (Board 0P3643), page 85
0P6502		Modbus	Modbus Connections (Board 0P6502), page 86

Non-Class 2/Non-SELV

Board	Terminal	Description	See
0P6547	J4939-J4941 ⁸³	Configurable output relays OUT1, OUT2, OUT3	Overview of Input Contacts and Output Relays, page 81
0P6549	J5607	MBB	Signal Cable Connections to the Switchgear (Boards 0P6547, 0P6548, 0P6549), page 83
	J5608	SIB	
	J5620	SSIB	
	J5621	UOB	
	J5622	UIB	
	J5611, J5612, J5613	External sync - L1, L2, L3	Signal Cables for External Synchronization, page 88
	J5609	Battery breaker 1	Signal Cable Connections to Classic Battery Cabinets (Boards 0P6547, 0P6549, 0P6552), page 84 and Signal Cable Connections to Battery Breaker Cabinet (Boards 0P6547, 0P6548, 0P6549), page 85
J5610	Battery breaker 2		
0P6548	J5529	Battery temperature sensor 1	
0P6547	J4942, J4943	24V supply 1	
	J4929, J4930	24V supply 2	
	J4923	DC shunt trip 1	
	J4924	DC shunt Trip 2	
0P6552	J9019	Battery breaker 3	
	J9020	Battery breaker 4	
	J9021	Battery temperature sensor 2	
	J9022, J9023	24V supply 3	
	J9024, J9025	24V supply 4	

83. These output relays can also be Class 2/SELV but the three output relays must have identical reference.

Route External Signal Cables to the Boards

1. Remove the two gland plates from the top of the I/O cabinet and drill holes for the applicable Class 2/SELV (A) and non-Class 2/non-SELV (B) signal cables. Install conduits and reinstall the plates.

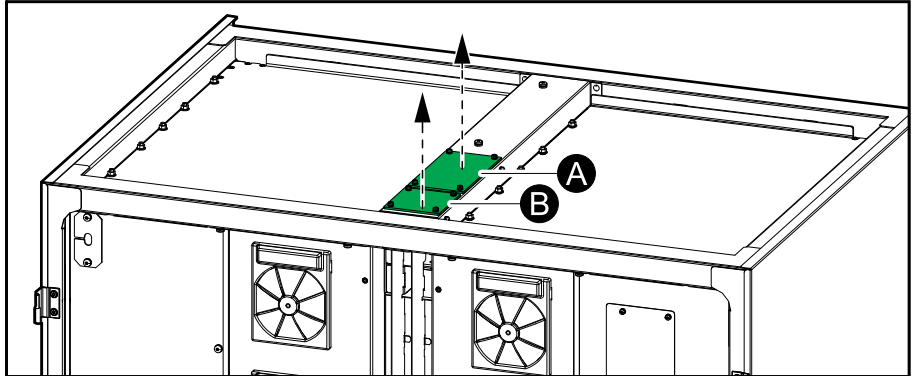

2. Route the external signal cables through the cable channel and through the correct openings:
 - A. Class2/SELV cables to the boards in the left door.
 - B. Class2/SELV cables to the boards in the right door.
 - C. Non-class 2/Non-SELV cables to the boards in the right door.

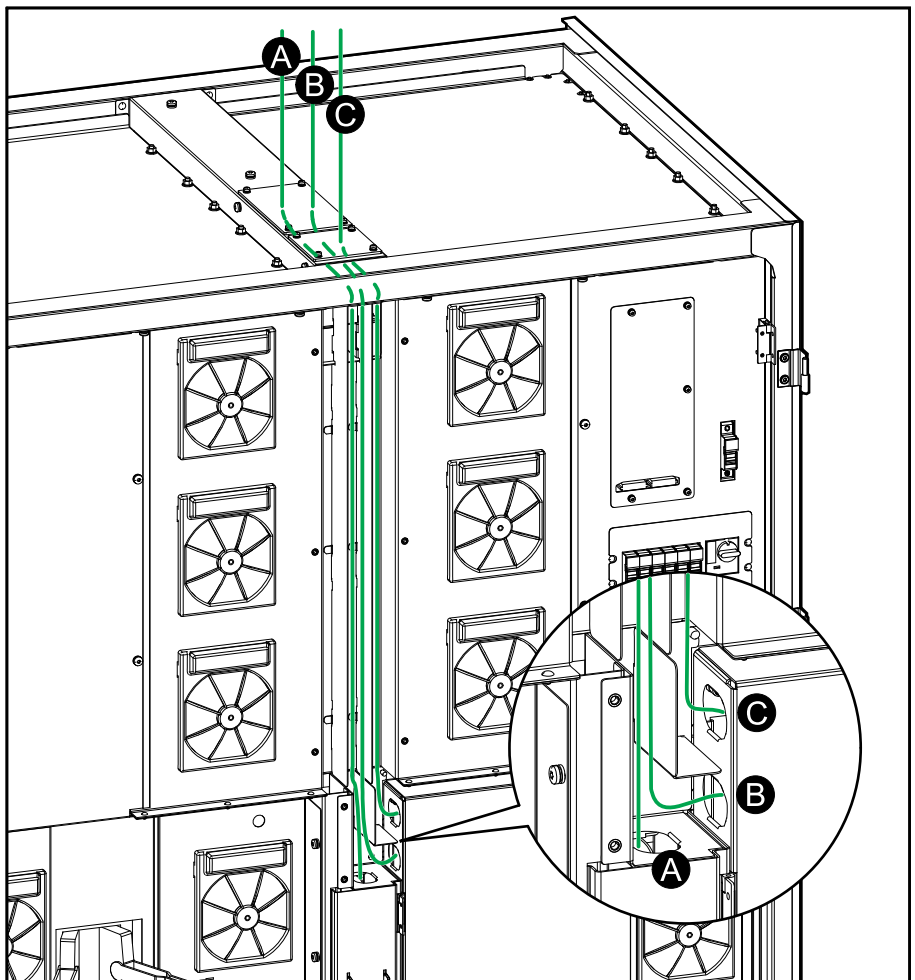

- 3. Route the external signal cables to the boards in the right door:
 - a. Open the right door and remove the plate from the inner door.

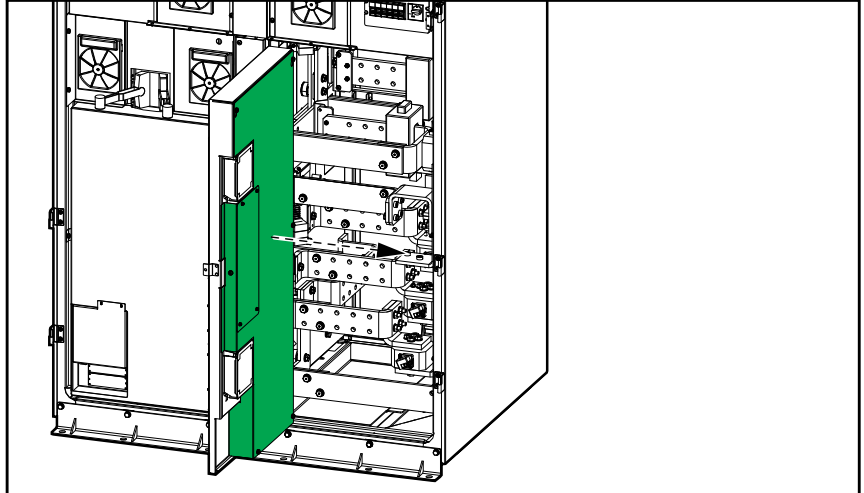

- b. Route the cables to the board terminals and fasten with the provided cable ties. Class 2/SELV cables (A) must be routed separated from non-Class 2/non-SELV cables (B) as shown on the illustration.

NOTE: The external signal cables must be long enough for the door to fully open.

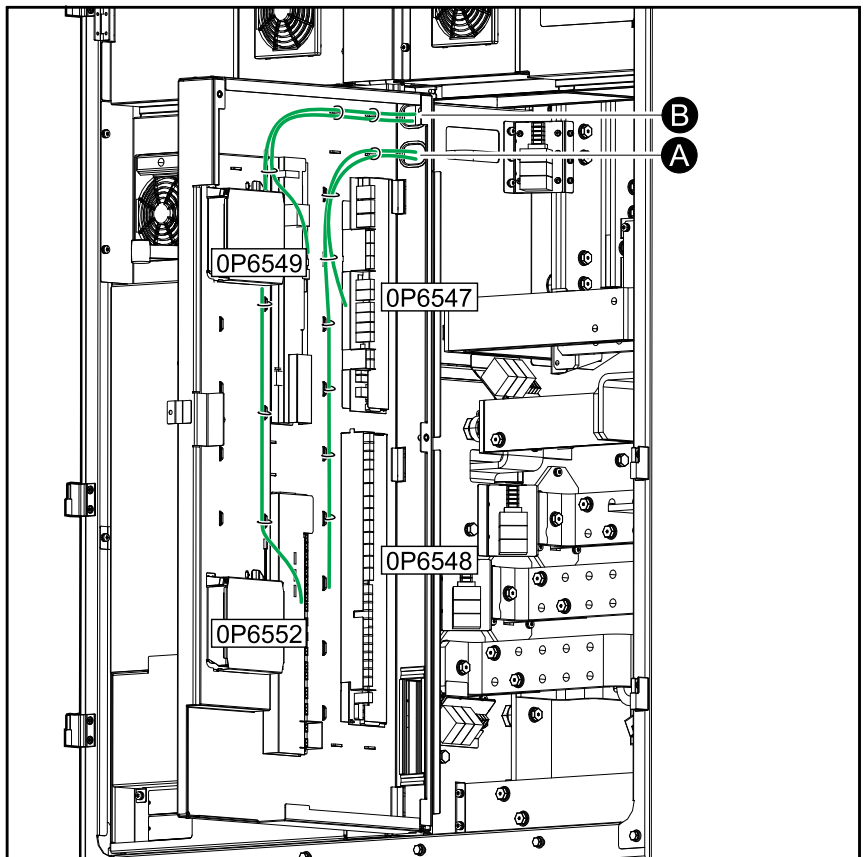

4. Route the external signal cables to the boards in the left door:

- a. Open the left door and remove the plate from the inner door.

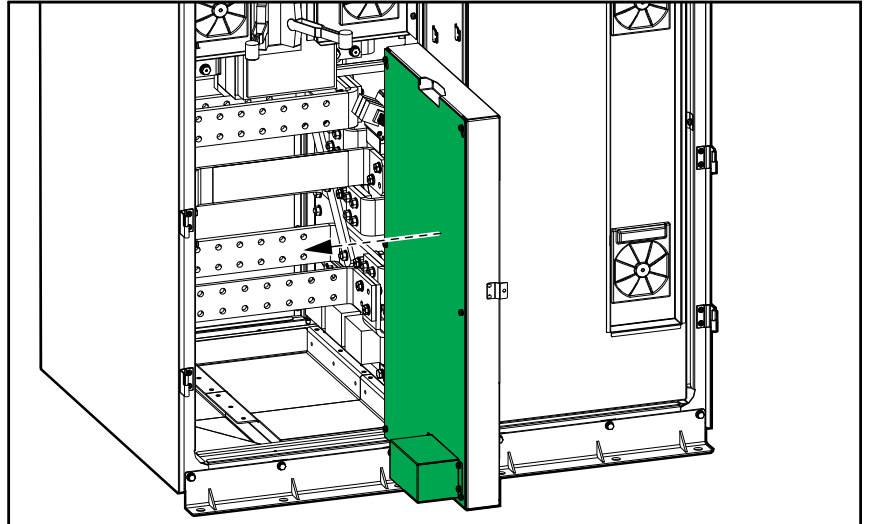

- b. Route the external signal cables to the terminals and fasten with the provided cable ties.

NOTE: The external signal cables must be long enough for the doors to fully open.

NOTE: Use the plate (A) for shielding of the Modbus cable.

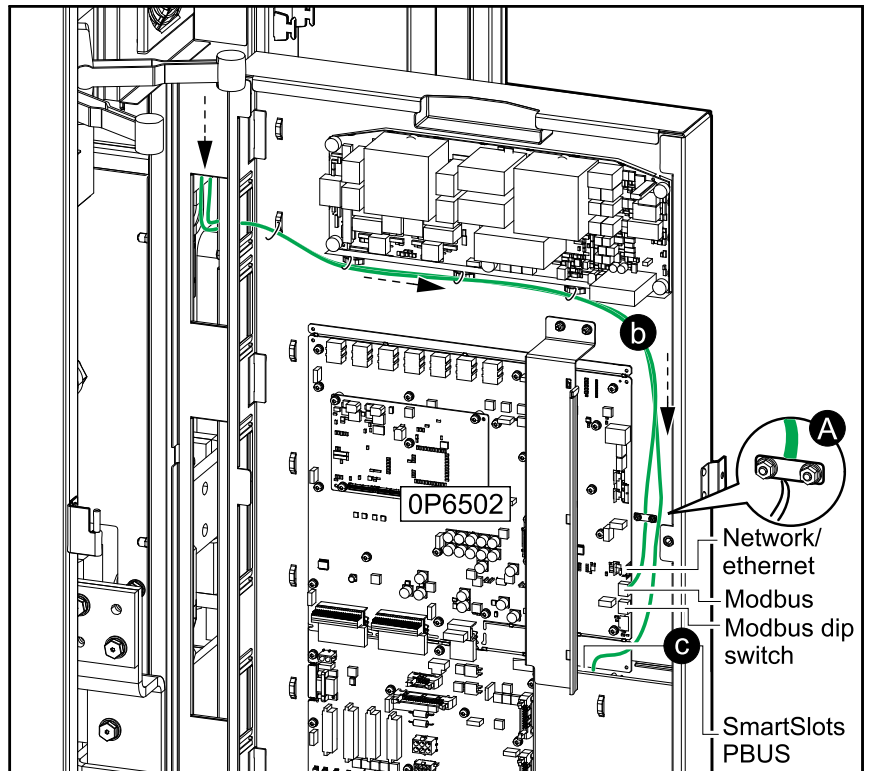

- c. Close the door and route the PBUS cables and cables for the network management cards to the front.

NOTE: If the input dry contact AP9810 is connected to AP9631 or AP9635CH, the total length of cables for connected equipment must not exceed 30 m (98 ft). Use the plate for shielding (A).

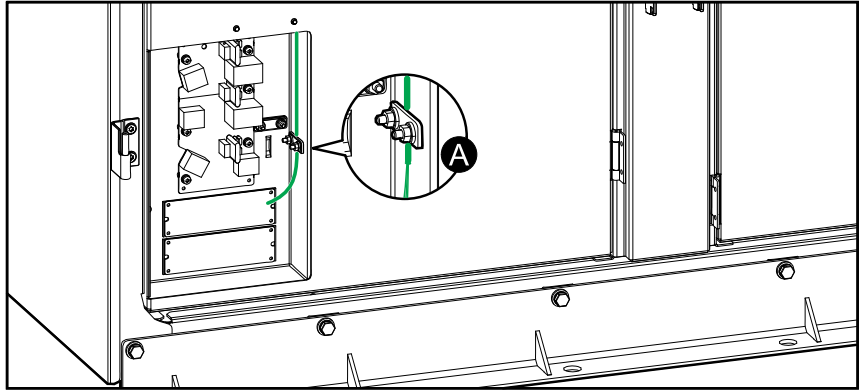

Overview of Input Contacts and Output Relays

Input Contacts

Do not connect any circuit to the input contacts unless it can be confirmed that the circuit is Class 2/SELV.

All circuits connected must have the same 0 V reference.

The input contacts support 24 VDC 10 mA.

The switch SW5500 on 0P6548 is used to select between internal SELV supply for inputs (standard setting) and external supply⁸⁴. If external supply is selected, the supply must be connected to J5530.

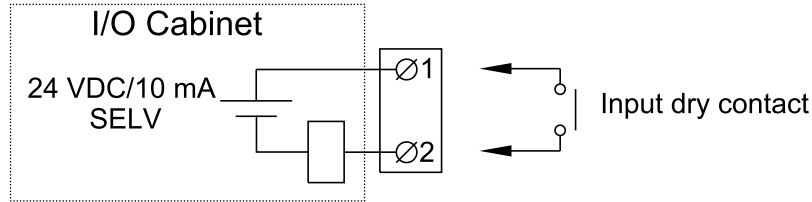

Name	Description	Location
IN 1 (Contact 1)	Configurable input contact	0P6548 terminal J5502 ⁸⁵
IN 2 (Contact 2)	Configurable input contact	0P6548 terminal J5503 ⁸⁵
IN 3 (Contact 3)	Configurable input contact	0P6548 terminal J5504 ⁸⁵
IN 4 (Contact 4)	Configurable input contact	0P6548 terminal J5505 ⁸⁵
IN 5 (Contact 5)	Configurable input contact	0P6548 terminal J5510 ⁸⁵
IN 6	UOB redundant AUX contact	0P6548 terminal J5509 ⁸⁵
IN 7	Transformer temperature switch	0P6548 terminal J5508 ⁸⁵
IN 8	External bonding contact	0P6548 terminal J5507 ⁸⁵
IN 9	Forced external synchronization input	0P6548 terminal J5506 ⁸⁵
IN 10	External synchronization requested	0P6548 terminal J5511 ⁸⁵
IN 11	Use static bypass standby	0P6548 terminal J5512 ⁸⁵
IN 14	MegaTie	0P6552 terminal J9027 ⁸⁵

Output Relays

NOTE: Maximum 250 VAC 5 A must be connected to the output relays.

All external circuitry must be fused with maximum 5 A fast acting fuses.

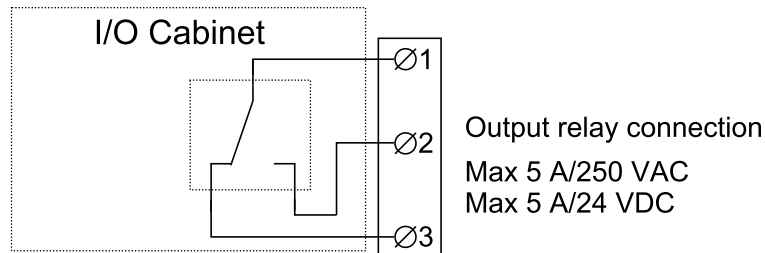

84. An external supply is useful in parallel systems where inputs are connected between different UPSs. This is to have a common reference and to avoid cross currents.

85. Class 2/SELV wiring

Name	Description	Location
OUT 1 (Relay 1)	Configurable output relay	0P6547 terminal J4939
OUT 2 (Relay 2)	Configurable output relay	0P6547 terminal J4940
OUT 3 (Relay 3)	Configurable output relay	0P6547 terminal J4941
OUT 4	Forced external synchronization output	0P6548 terminal J5520 ⁸⁶
OUT 5	MegaTie	0P6548 terminal J5521 ⁸⁶
OUT 6	External synchronization requested output	0P6548 terminal J5522 ⁸⁶
OUT 7	UPS in inverter ON	0P6548 terminal J5523 ⁸⁶
OUT 8 (Relay 4)	Configurable output relay	0P6548 terminal J5524 ⁸⁶
OUT 9 (Relay 5)	Configurable output relay	0P6548 terminal J5525 ⁸⁶
OUT 10 (Relay 6)	Configurable output relay	0P6548 terminal J5528 ⁸⁶
OUT 14	Bonding contactor	0P6552 terminal J9029 ⁸⁶

NOTE: Refer to the operation manual for configuration options.

⁸⁶. Class 2/SELV wiring

Signal Cable Connections to the Switchgear (Boards 0P6547, 0P6548, 0P6549)

NOTE: The unit output breaker UOB must include two separated AUX switches.

NOTE: The solenoid key release unit (SKRU) is only applicable to 480 V systems.

All circuits connected must have the same 0 V reference.

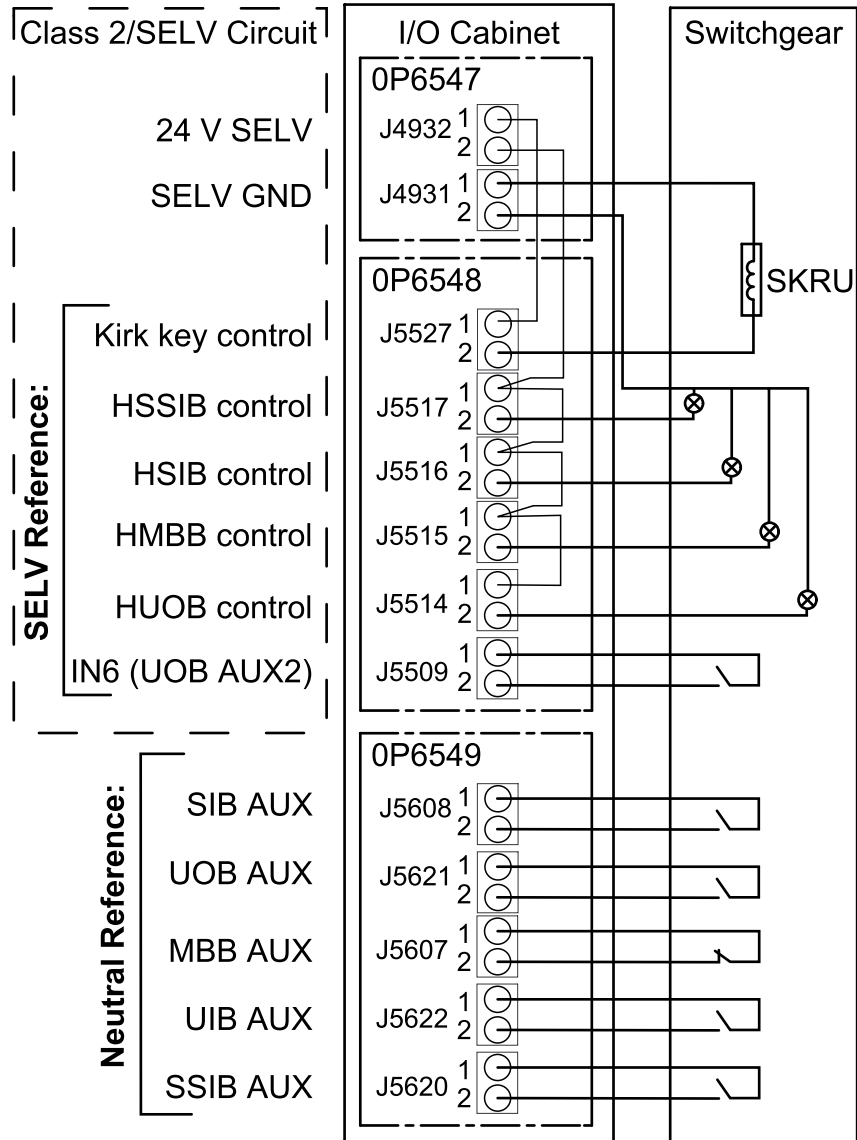

Signal Cable Connections to Classic Battery Cabinets (Boards 0P6547, 0P6549, 0P6552)

NOTE: The illustration below shows a system with four battery banks, each consisting of one classic battery cabinet. Connect signal cables according to the number of classic battery cabinets in your installation.

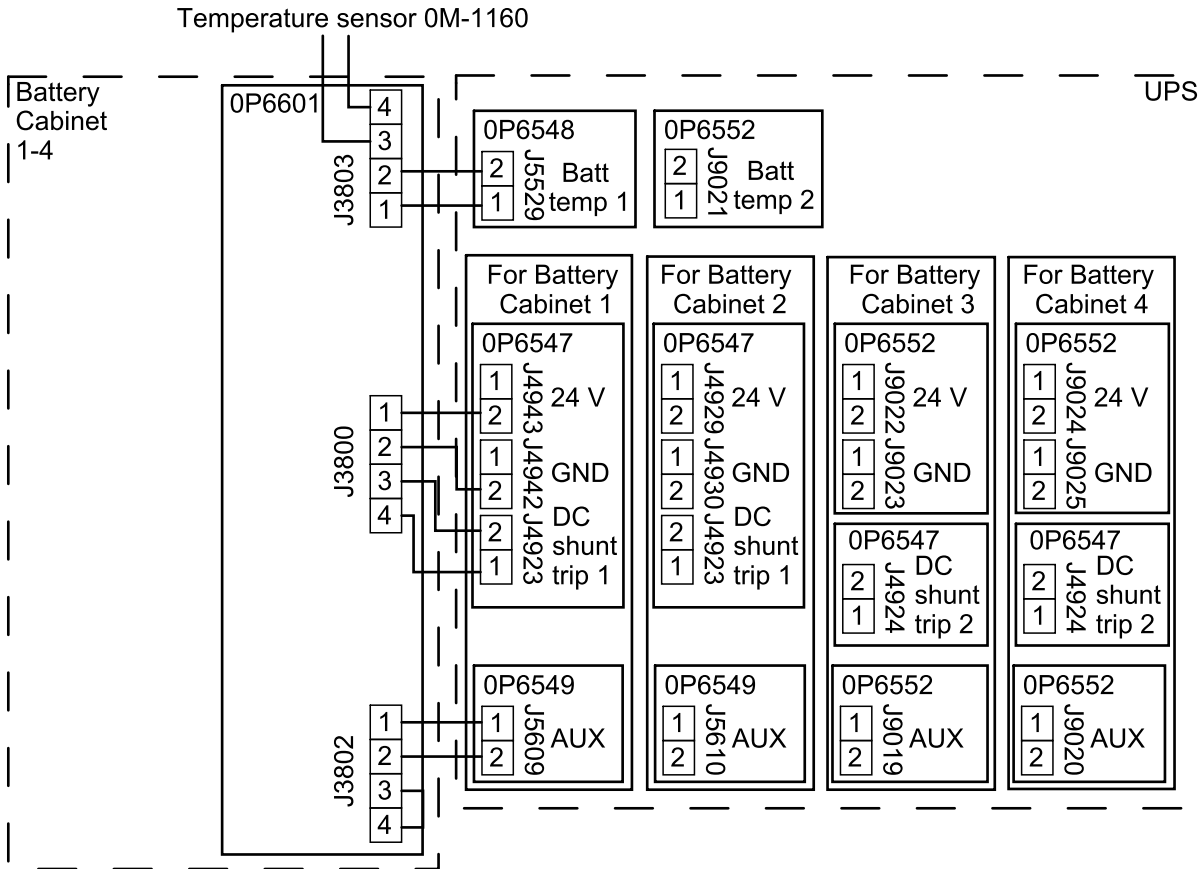

If the battery bank is consisting of two classic battery cabinets, connect signal cables between the two classic battery cabinets in one battery bank as shown.

Battery Bank

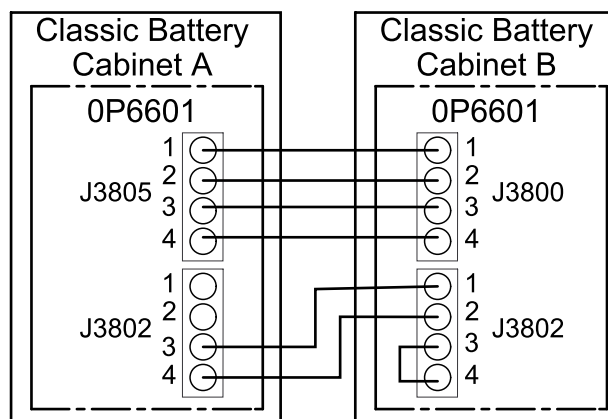

Signal Cable Connections to Battery Breaker Cabinet (Boards 0P6547, 0P6548, 0P6549)

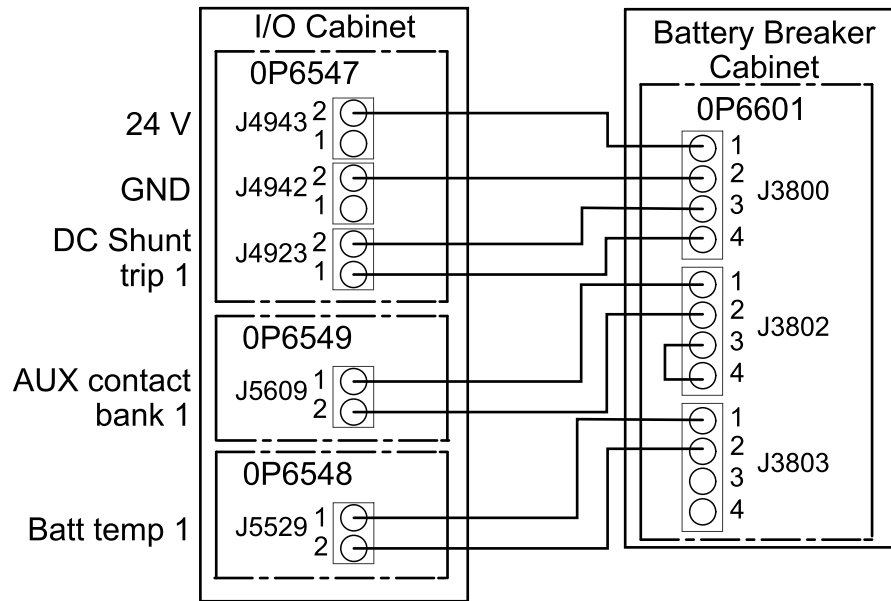

PBUS Cable Connections (Board 0P3643)

NOTE: The PBUS 1 cables are white and the PBUS 2 cables are red.

NOTE: The total length of the PBUS cables must not exceed 60 m (197 ft).

Example of System with Four UPSs in Parallel

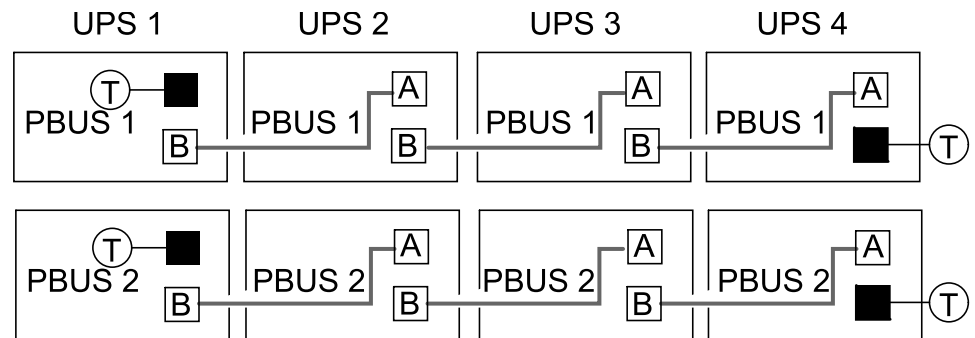

Modbus Connections (Board 0P6502)

NOTE: Terminators for Modbus connection is provided in installation kit 0H-9385.

NOTE: Shielded cables must be used for Modbus connections. The shield connection to the ground must be as short as possible (ideally below 1 cm). All Modbus signal cables shall be double insulated/jacket cable and minimum rated for 30 VDC.

2-Wire Connection with One UPS

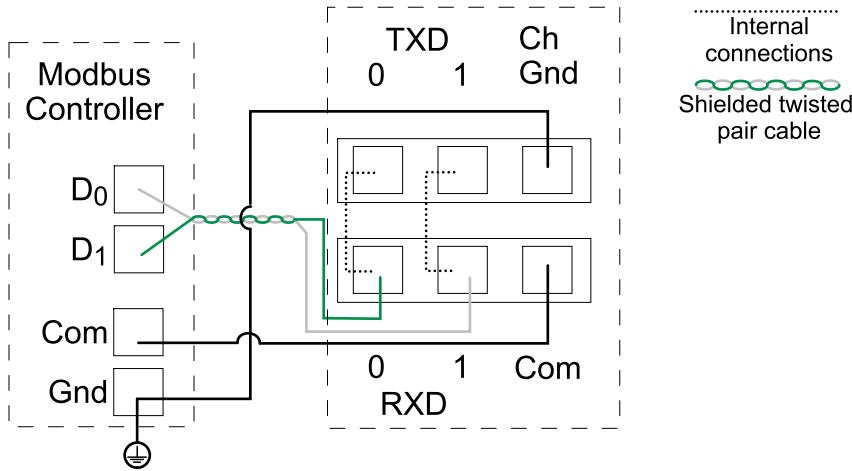

Example: 2-Wire Connection with Two UPSs

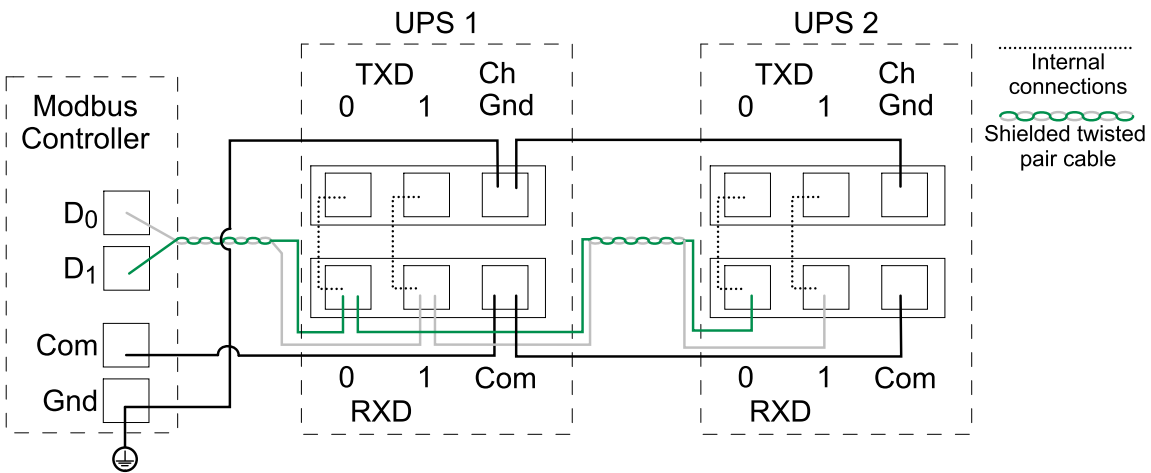

Example: 4-Wire Connection with One UPS

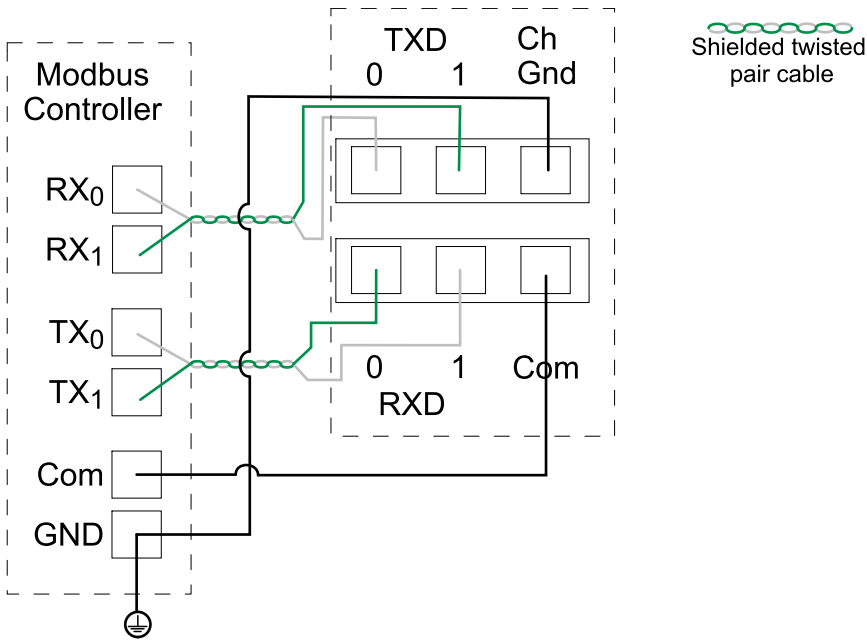

Example: 4-Wire Connection with Two UPSs

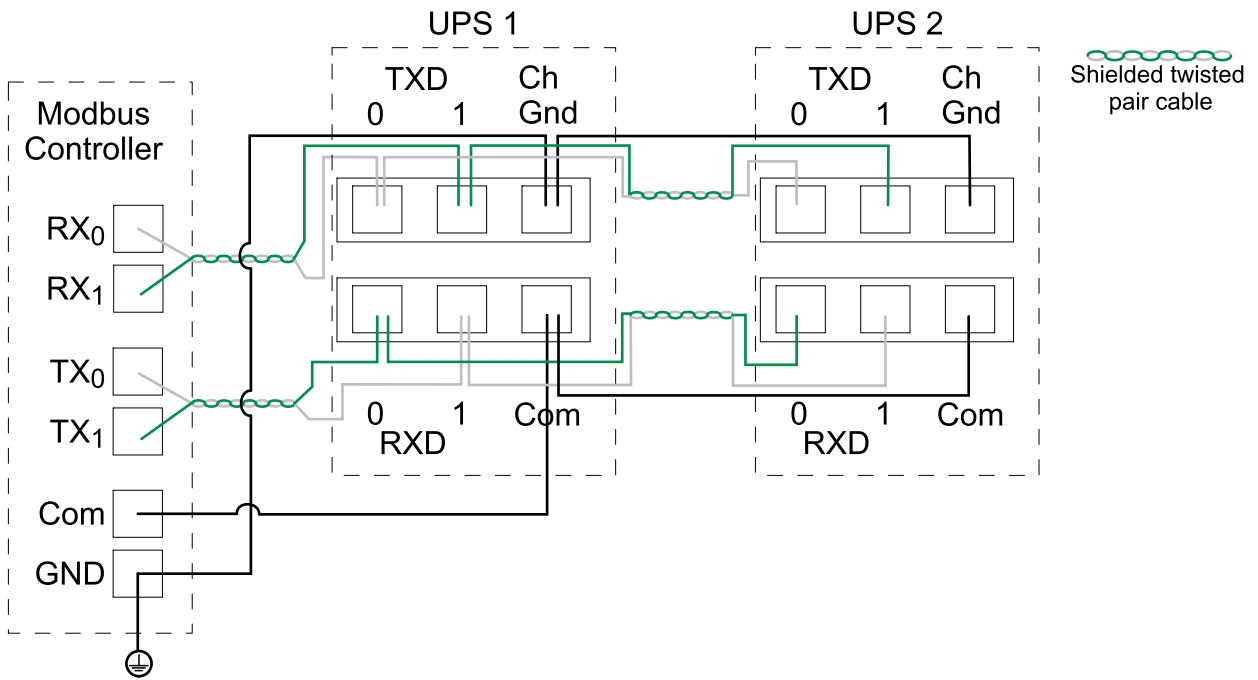

Modbus Dip Switch Settings

The Modbus dip switches must be set to match your installation:

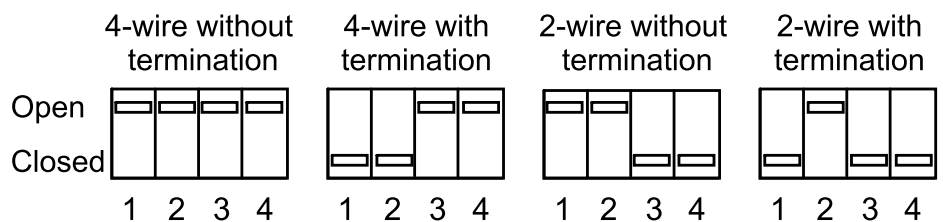

Connect the Emergency Power Off (EPO)

Do not connect any circuit to the EPO terminal block unless it can be confirmed that the circuit is Class 2/SELV.

All circuits connected must have the same 0 V reference.

The EPO input supports 24 VDC.

1. Route the cables from your EPO through the top of the I/O cabinet and to the EPO terminals J4936-J4938 on 0P6547 as shown in Route External Signal Cables to the Boards, page 77.
2. Connect the building EPO to the terminal block according to one of the options below.

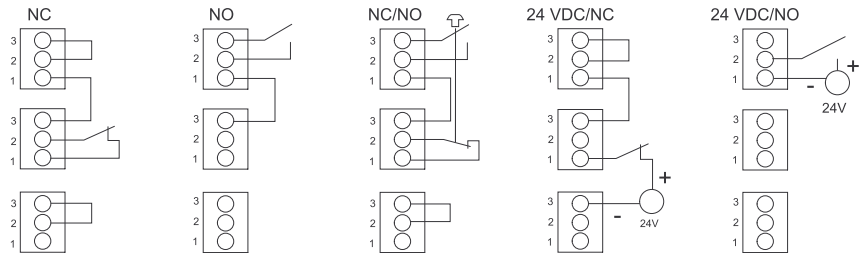

NOTE: Do not connect the terminal block to the board. Signal cables will be connected by Schneider Electric during the assembly service.

Signal Cables for External Synchronization

The maximum voltage for external synchronization is equal to the input voltage range given in the specifications. The non-Class 2/non-SELV cables for external synchronization shall be a jacket cable and rated for 600 VAC.

1. Route the external synchronization cables through the top of the I/O cabinet to 0P6549 as shown in Route the Signal Cables between the I/O Cabinet and the Power Cabinets, page 71.

2. Connect the three phases to the terminal block:

NOTE: The phases from the synchronization source must be protected by a fuse of maximum 0.5 A.

NOTE: Do not connect the terminal block to the board. Signal cables will be connected by Schneider Electric during the assembly service.

- a. Connect L1 to J5611 on 0P6549.
- b. Connect L2 to J5612 on 0P6549.
- c. Connect L3 to J5613 on 0P6549.

Signal Cable Connections for Basic UPS Synchronization to a Fixed Voltage Source (Boards 0P6548, 0P6549)

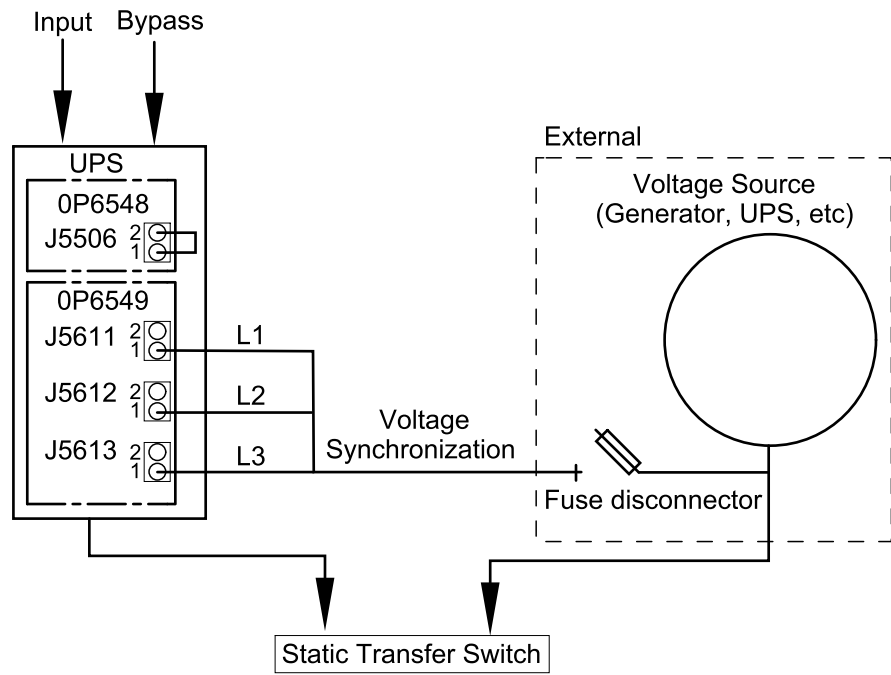

Signal Cable Connections for Dual UPS Synchronization with a Floating Synchronization Master (Boards 0P6548, 0P6549)

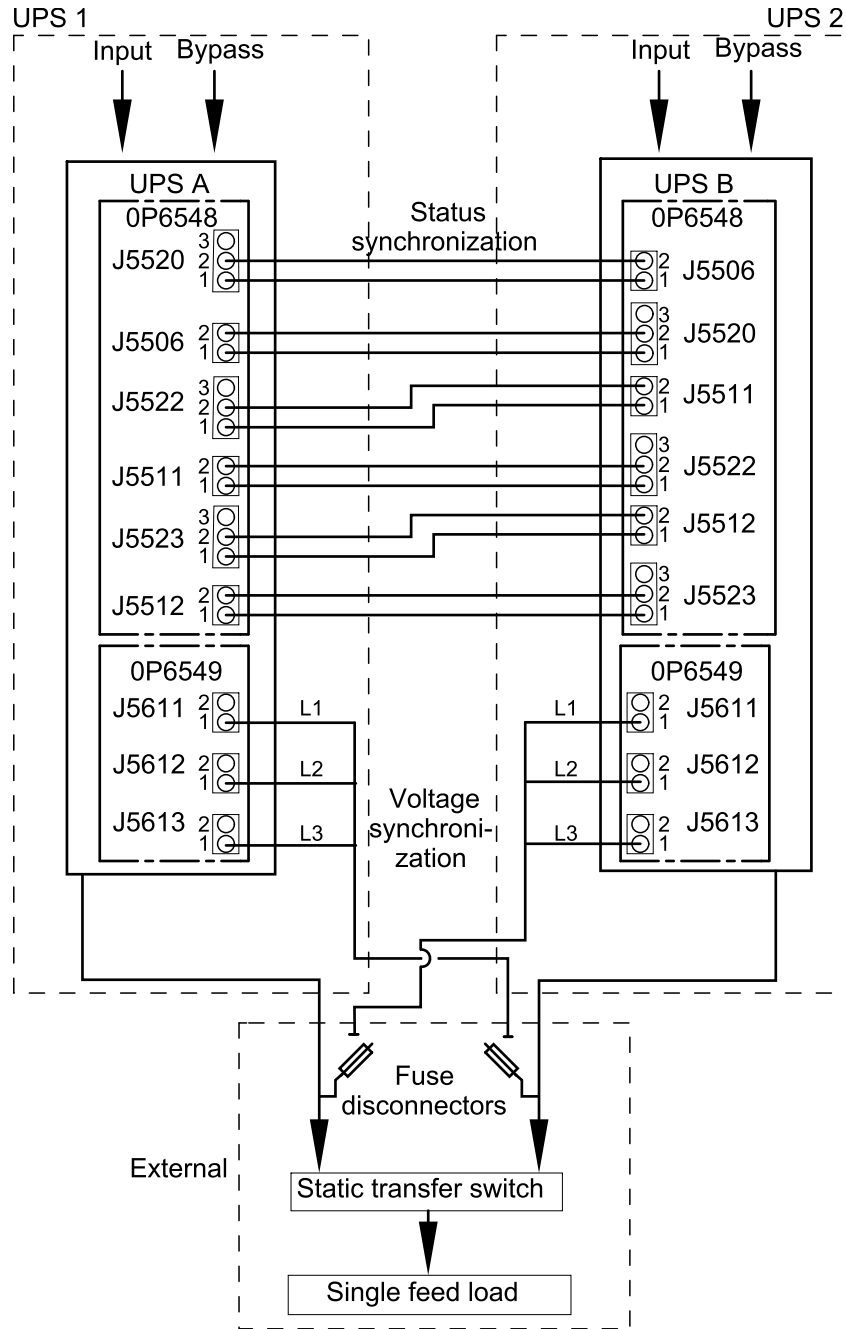

Signal Cable Connections for Fixed Parallel Synchronization Master (Boards 0P6548, 0P6549)

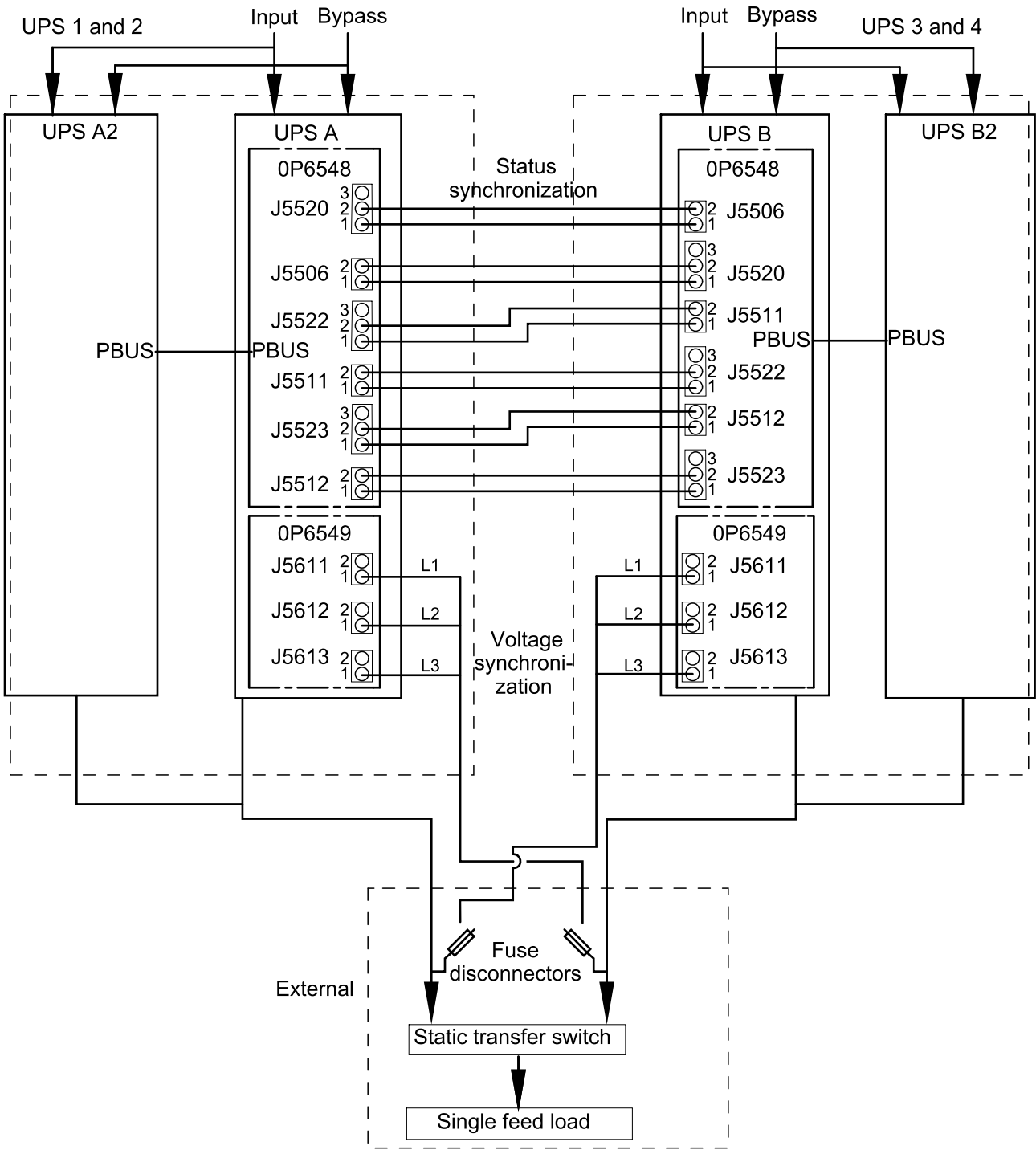

Backfeed Protection

DANGER

HAZARD OF ELECTRIC SHOCK, EXPLOSION, OR ARC FLASH

Mandatory backfeed protection on bypass must be implemented by one of the following methods:

- Preinstalled backfeed breaker BF2 in the UPS.
- Installation of internal backfeed kit (GVXOPT001) in the UPS. Follow the installation manual provided with the internal backfeed kit.
- Installation of upstream breaker with shunt trip connected to the UPS. See diagrams and instructions in *Installation of Third Party Backfeed Protection*, page 92.

Failure to follow these instructions will result in death or serious injury.

Installation of Third Party Backfeed Protection

Connect the breaker shunt trip and AUX switch to the UPS as shown below. Use double insulated cables. Breaker shunt trip must be rated for 24 VDC nominal, inrush max 100 W. The cable supplying the shunt trip shall be a jacket cable and rated for 600 VAC. The cables shall be sized taking the cable voltage drop and the recommendation of the shunt trip manufacturer into consideration.

Label 885-91965 (provided with the UPS) must be placed visible at the bypass upstream breaker.

DANGER

HAZARD OF ELECTRIC SHOCK, EXPLOSION, OR ARC FLASH

In systems where backfeed protection is not a part of the standard design, an automatic isolation device (Schneider Electric backfeed protection option or other device, such as a breaker, switch, or contactor with trip function, meeting the requirements of IEC62040-1 or UL1778 5th edition – depending on which standard apply to your local area), is required to be installed to prevent hazardous voltage or energy at the input terminals of the isolation device. The device must be rated and controlled according to the specifications in this manual.

Failure to follow these instructions will result in death or serious injury.

When the UPS input is connected through external isolators that, when opened, isolate the neutral or when the automatic backfeed isolation is provided external to the equipment or is connected to an IT power distribution system, a label must be fitted at the UPS input terminals, and on all primary power isolators installed remotely from the UPS area and on external access points between such isolators and the UPS, by the user, displaying the following text (or equivalent in a language which is acceptable in the country in which the UPS system is installed):

DANGER

HAZARD OF ELECTRIC SHOCK, EXPLOSION, OR ARC FLASH

Risk of voltage backfeed. Before working on this circuit: Isolate the UPS and check for hazardous voltage between all terminals including the protective earth.

Failure to follow these instructions will result in death or serious injury.

UPS and Third Party Backfeed Protection – Single Mains

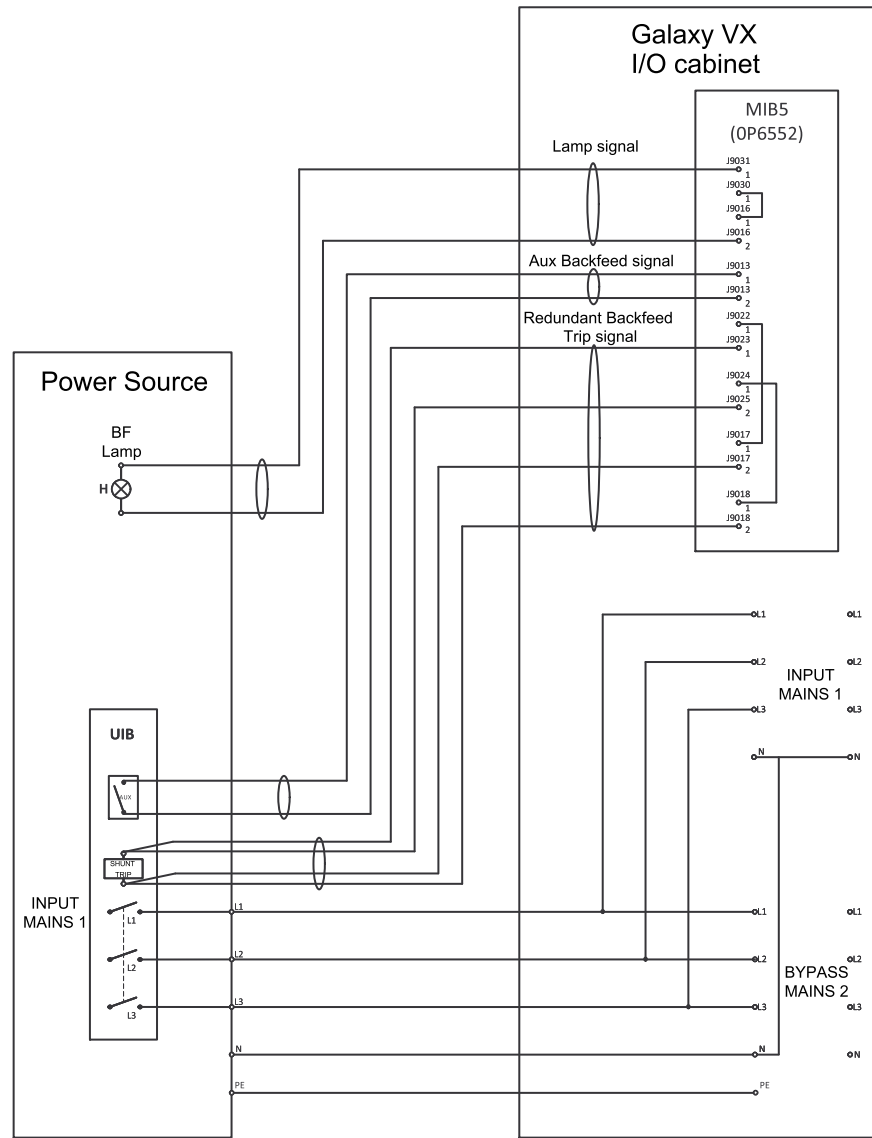

NOTE: One extra AUX switch is needed in UIB for backfeed signalling.

UPS and Third Party Backfeed Protection – Dual Mains

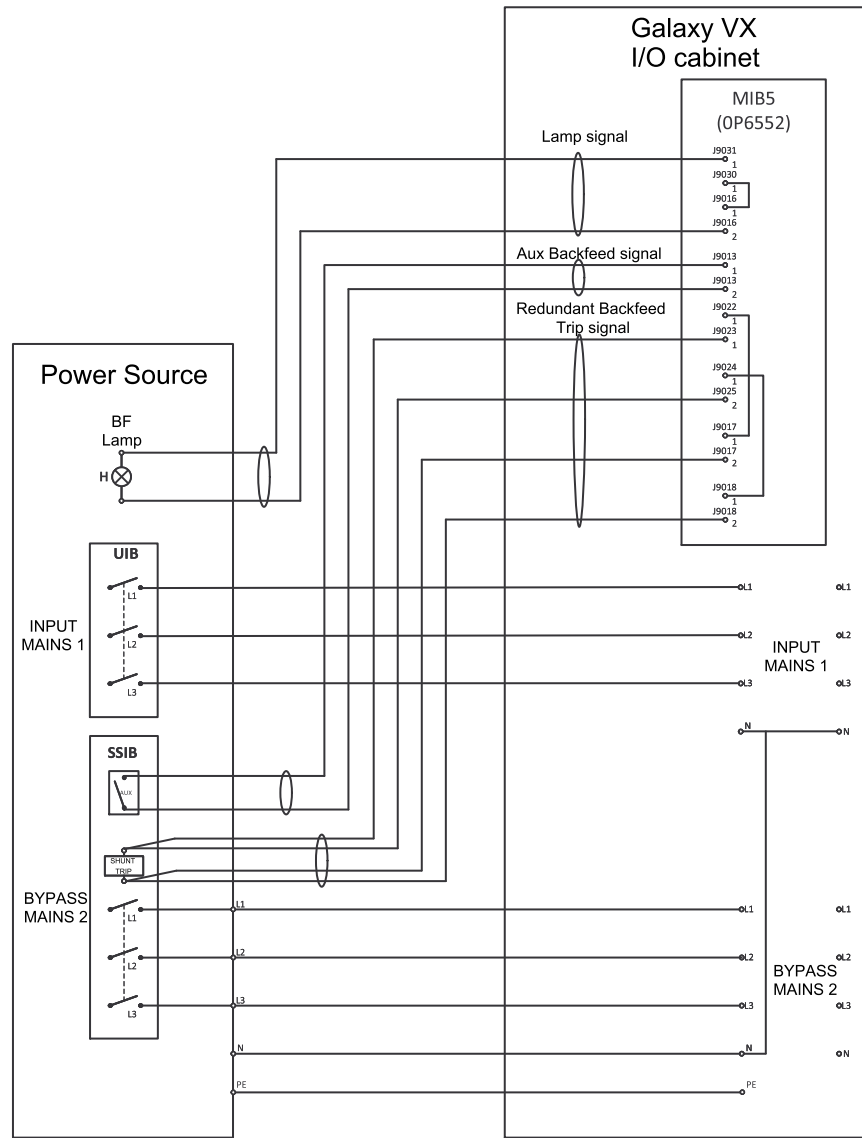

NOTE: One extra AUX switch is needed in SSIB for backfeed signalling.

Final Mechanical Assembly

Final Mechanical Assembly of the I/O Cabinet

⚠️⚠️ DANGER

HAZARD OF ELECTRIC SHOCK, EXPLOSION, OR ARC FLASH

All panels and covers must be properly reinstalled prior to energizing the UPS.

Failure to follow these instructions will result in death or serious injury.

1. Reinstall the cover on the door in the left side and fasten with the screws.

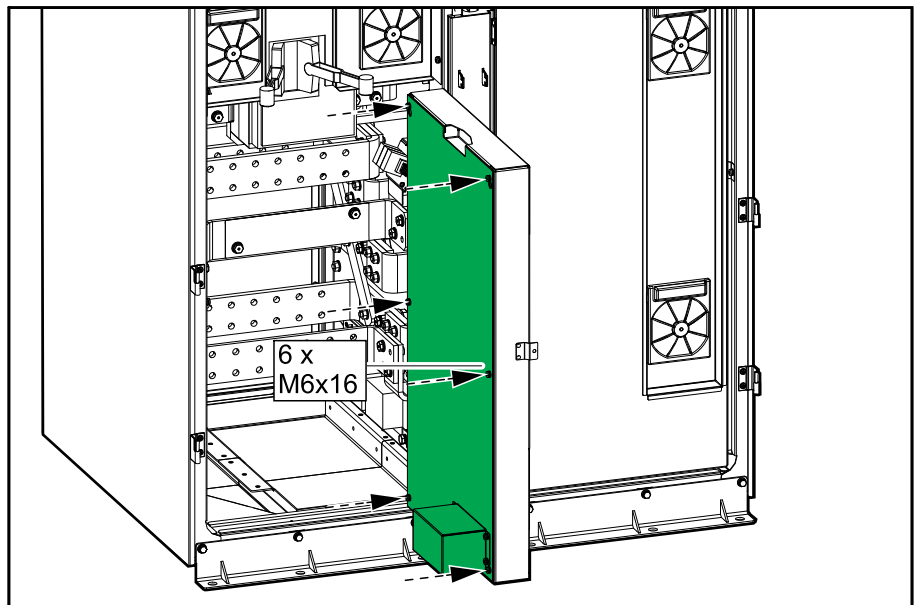

2. Close the door and fasten with the screw.

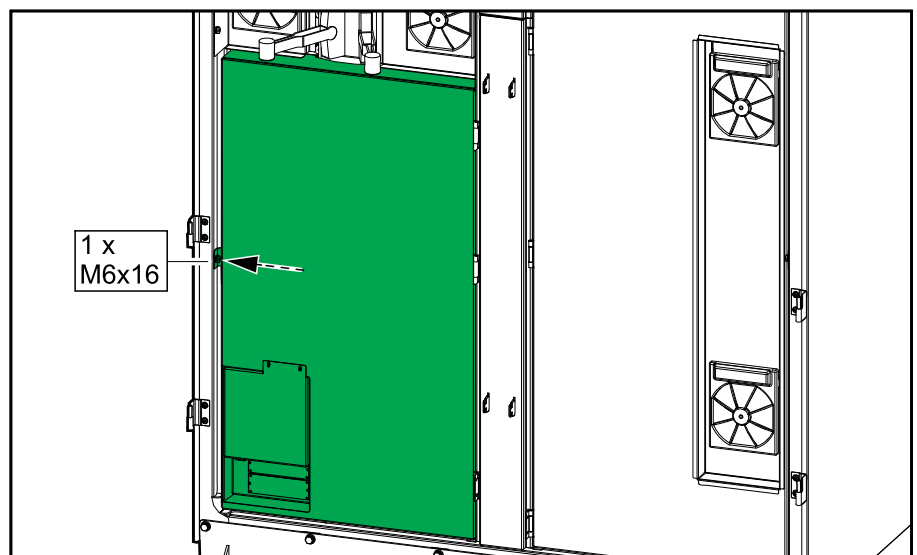

3. Reinstall the indicated cover if removed and fasten with the screws.

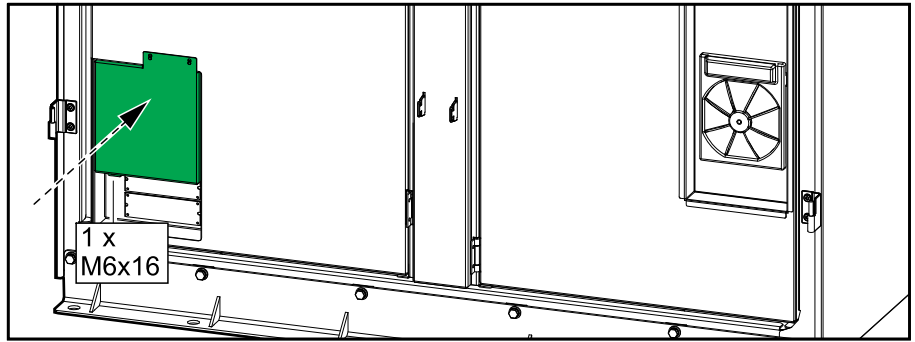

4. Reinstall the cover on the door in the right side and fasten with the screws.

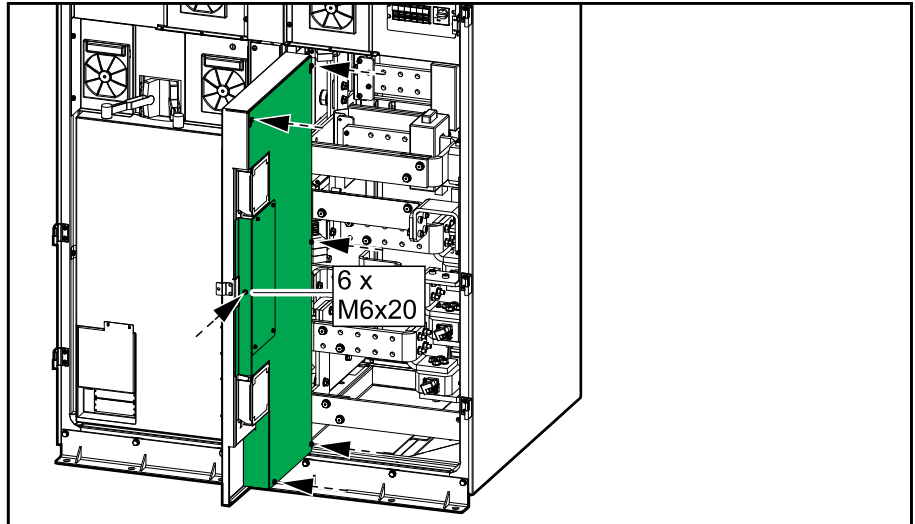

5. Close the door and fasten with the screw.

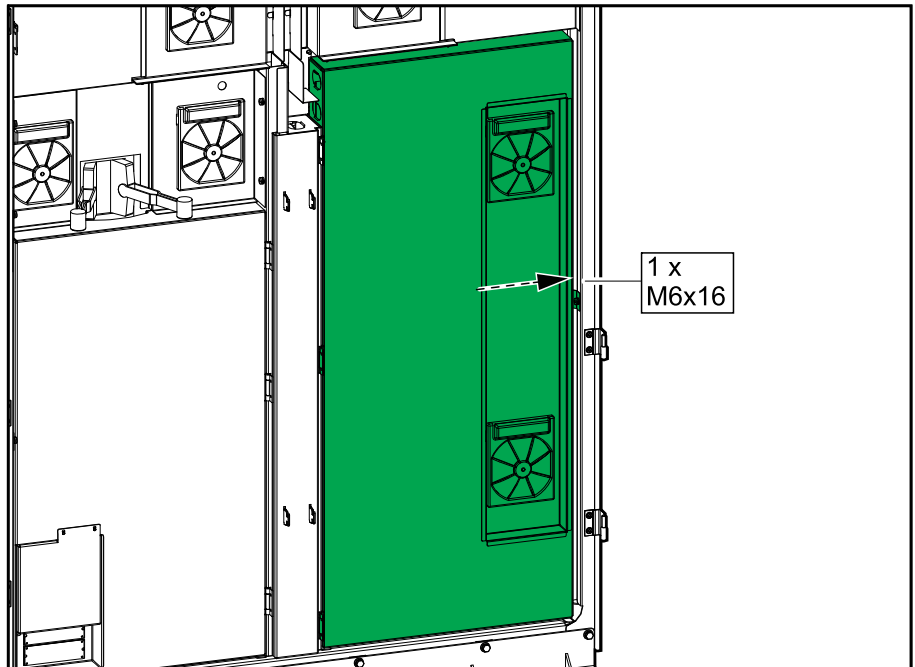

- Reinstall the two indicated covers and close the door in the top right corner. Fasten with screws.

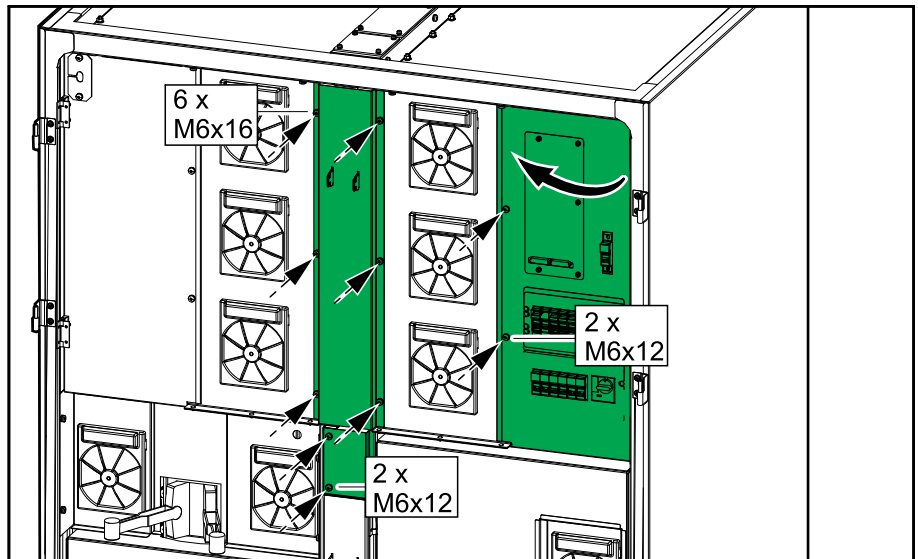

- Close the front doors.

Final Mechanical Assembly of the Power Cabinets

⚠️ DANGER

HAZARD OF ELECTRIC SHOCK, EXPLOSION, OR ARC FLASH

All panels and covers must be properly reinstalled prior to energizing the UPS.

Failure to follow these instructions will result in death or serious injury.

- Reinstall the three plates in the given order (a-c) on each power cabinet.

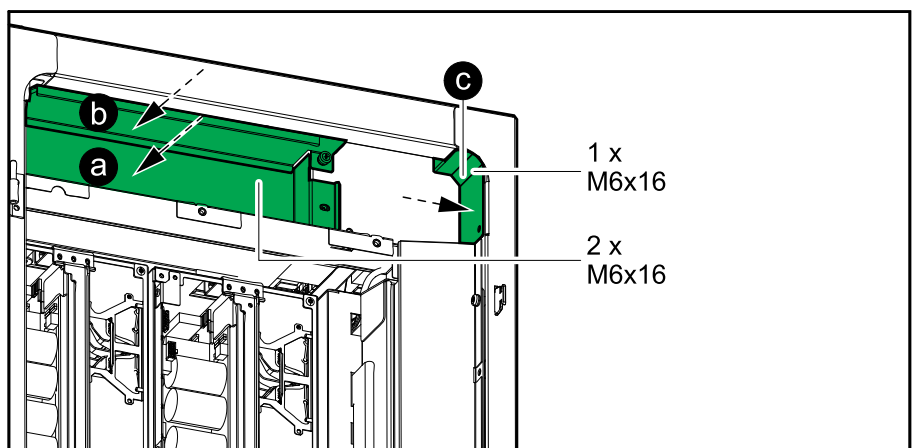

Decommission or Move the UPS to a New Location

NOTE: Contact Schneider Electric for removal of the interconnection busbars between the cabinets.

1. Shut down the UPS completely – follow the instructions in the UPS operation manual.
2. Lockout/Tagout all breakers in the switchgear in the OFF (open) position.
3. Lockout/Tagout all battery breakers in the switchgear/battery solution in the OFF (open) position.
4. Open the front door of the UPS.
5. If present, Lockout/Tagout the backfeed breaker BF2 in the OFF (open) position.
6. Open the front door of the I/O cabinet and the power cabinets.
7. Open the two inner doors of the I/O cabinet.

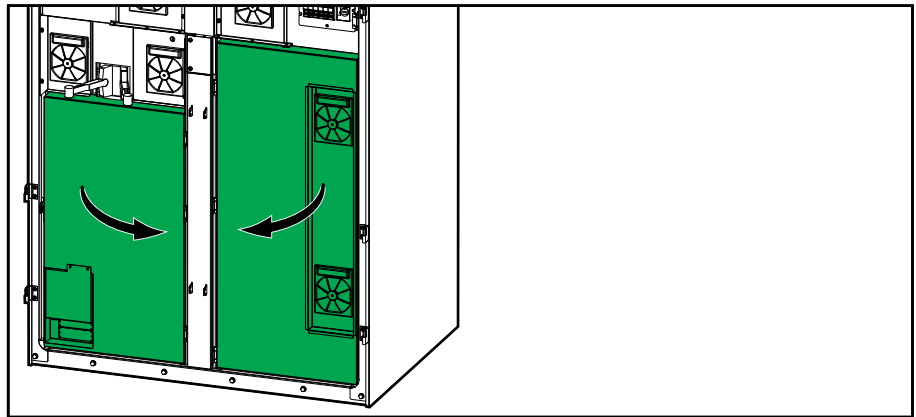

8. Measure for and verify ABSENCE of voltage on each input/bypass/output/DC busbar before continuing.

⚠️ DANGER

HAZARD OF ELECTRIC SHOCK, EXPLOSION, OR ARC FLASH

Measure for and verify ABSENCE of voltage on each input/bypass/output/DC busbar before continuing.

Failure to follow these instructions will result in death or serious injury.

Front View of the I/O Cabinet

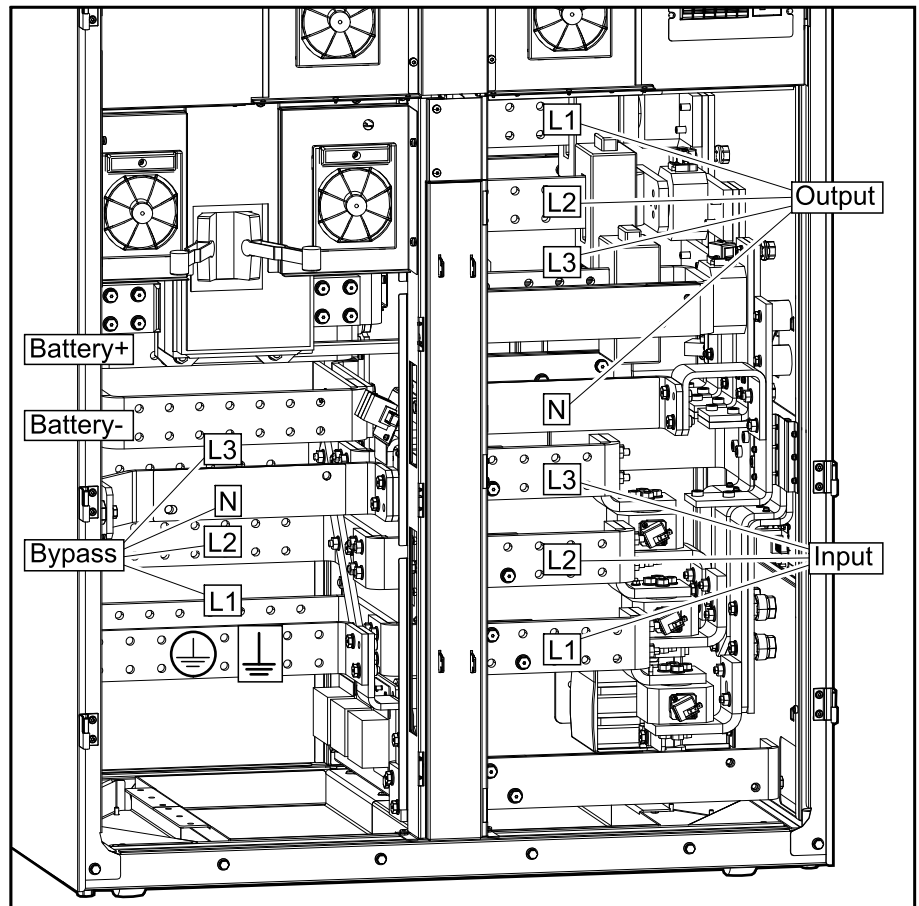

9. Disconnect and remove all power cables from the I/O cabinet. See *Connect the Power Cables in a 380/400/415/440 V System*, page 63 or *Connect the Power Cables in a 480 V System*, page 66 for details.
10. If present, disconnect and remove the external supply cables from the Lithium-ion battery solution. See *Connect Cables to the External Supply for Lithium-ion Battery Solution (Optional)*, page 68 for details.
11. Disconnect and remove all signal cables from the I/O cabinet. See *Signal Cables*, page 71 for details.
12. Contact Schneider Electric for removal of the interconnection busbars between the cabinets. The interconnections busbars must only be removed by a Schneider Electric-certified field service representative or service partner.
13. Remove the seismic front anchoring brackets from the cabinets. Save for reinstallation. See *Mount the Front Anchoring Brackets*, page 70 for details.

14. Remove the top baying brackets and interconnection screws from the cabinets. Release the cabinets from the rear anchoring brackets by loosening the bolts on the front of the cabinets. See *Position the Cabinets*, page 54 for details.
15. Reinstall all removed plates and covers in the cabinets. See *Final Mechanical Assembly of the I/O Cabinet*, page 95 and *Final Mechanical Assembly of the Power Cabinets*, page 97 for details.
16. Close and lock the front door of the cabinets.
17. Raise the feet of the cabinets until the casters have full contact with the floor.
18. You can now move each cabinet individually by rolling it over the floor on the casters.

▲ WARNING

TIPPING HAZARD

- The casters of the cabinet are exclusively for transport on flat, even, hard, and horizontal surfaces.
- The casters of the cabinet are intended for transport over short distances (i.e. inside the same building).
- Move at a slow pace and pay close attention on the floor conditions and the balance of the cabinet.

Failure to follow these instructions can result in death, serious injury, or equipment damage.

19. Remove the rear anchoring brackets from the floor. Save for reinstallation. See *Mount the Rear Anchoring Brackets*, page 52 for details.

20. **For transport over longer distances or in conditions that are not suitable for the casters of the cabinet:**

⚠ WARNING

TIPPING HAZARD

For transport over longer distances or in conditions that are not suitable for the casters of the UPS, ensure:

- that personnel performing the transport have necessary skills and have received adequate training;
- to use appropriate tools to safely lift and transport the cabinet;
- to protect the product against damage by using appropriate protection (like wrapping or packaging).

Failure to follow these instructions can result in death, serious injury, or equipment damage.

⚠ WARNING

TOP-HEAVY CABINET

The power cabinet is top-heavy. Take appropriate precautions during handling and preparation for transport/shipment.

Failure to follow these instructions can result in death, serious injury, or equipment damage.

Transportation requirements:

- Mount the cabinet in a vertical position in the center of a suitable pallet. The pallet must be suitable for the weight of the cabinet. The I/O cabinet weighs 620 kg (1367 lbs). The power cabinet weighs 540 kg (1190 lbs).
- Use appropriate means of fixation to mount the cabinet to the pallet.

⚠ DANGER

TIPPING HAZARD

- The cabinet must be appropriately fixed to the pallet immediately after being placed on the pallet.
- The fixation hardware must be strong enough to withstand vibrations and shocks during loading, transport, and unloading.

Failure to follow these instructions will result in death or serious injury.

⚠ WARNING

UNEXPECTED EQUIPMENT BEHAVIOR

Do not lift the cabinet with a forklift/pallet truck directly on the frame as it may bend or damage the frame.

Failure to follow these instructions can result in death, serious injury, or equipment damage.

21. Perform one of the following:

- Decommission the cabinets, OR
- Move the the I/O cabinet/power cabinet to a new location to install it.

22. **Only for installing the UPS in a new location:** Follow the installation manual to install the I/O cabinet and power cabinets in the new location. See Installation Procedure, page 51 for installation overview. Startup must only be performed by Schneider Electric.

 **DANGER****HAZARD OF ELECTRIC SHOCK, EXPLOSION, OR ARC FLASH**

Startup must only be performed by Schneider Electric.

Failure to follow these instructions will result in death or serious injury.

Schneider Electric



* 9 9 0 - 6 2 6 4 6 - 0 0 1 *

As standards, specifications, and design change from time to time, please ask for confirmation of the information given in this publication.

© 2020 – 2025 Schneider Electric. All rights reserved.

990-6264G-001