



Liebert EXS 80kVA UPS

User Manual

The information contained in this document is subject to change without notice and may not be suitable for all applications. While every precaution has been taken to ensure the accuracy and completeness of this document, Vertiv assumes no responsibility and disclaims all liability for damages resulting from use of this information or for any errors or omissions. Refer to other local practices or building codes as applicable for the correct methods, tools, and materials to be used in performing procedures not specifically described in this document.

The products covered by this instruction manual are manufactured and/or sold by Vertiv. This document is the property of Vertiv and contains confidential and proprietary information owned by Vertiv. Any copying, use or disclosure of it without the written permission of Vertiv is strictly prohibited.

Names of companies and products are trademarks or registered trademarks of the respective companies. Any questions regarding usage of trademark names should be directed to the original manufacturer.

Technical Support Site

If you encounter any installation or operational issues with your product, check the pertinent section of this manual to see if the issue can be resolved by following outlined procedures.

Table of Contents

Special Declaration	1
Safety Precaution	2
1 Overview	5
1.1 Features	5
1.2 Design Concept	6
1.2.1 System Design	6
1.2.2 Bypass	7
1.2.3 System Control Principle	7
1.2.4 UPS Power Supply Switch Configuration	8
1.2.5 Battery Circuit Breaker (BCB).....	9
1.3 Parallel System.....	9
1.3.1 Parallel System Features.....	9
1.3.2 Parallel System Requirements.....	10
1.4 UPS States and Operating Modes.....	10
1.5 Battery Management.....	13
1.5.1 Normal Function.....	13
1.5.2 Advanced Function.....	14
1.5.3 Battery Temperature Compensation	15
1.6 Battery Protection.....	15
2 Mechanical Installation	17
2.1 Precautions.....	17
2.2 Transportation.....	18
2.3 Tools.....	18
2.4 Unpacking	20
2.5 Initial Inspection	22
2.6 Environmental Requirements	22
2.6.1.UPS Room	22
2.6.2.Reserved Space.....	23
2.6.3.Battery Room.....	23
2.6.4.Storage Environment.....	24

2.7 Mechanical Requirements	24
2.7.1.Moving Cabinet	24
2.7.2.Clearance.....	24
2.7.3.Cable Access Mode.....	24
2.8 Installation Drawings.....	25
3 Electrical Installation.....	27
3.1 Wiring of Power Cable.....	27
3.1.1 System Configuration	27
3.1.2 Maximum Steady State AC and DC Currents.....	28
3.1.3 Recommended CSA of UPS Cable.....	28
3.1.4 Selection of UPS I/O Switch.....	28
3.1.5 Power Cable Connecting Terminal.....	29
3.1.6 Protection Ground	29
3.1.7 Notes.....	29
3.1.8 Power Cable Connection Steps.....	29
3.2 Wiring of Signal Cable.....	32
4 Operator Control And Display Panel.....	33
4.1 Introduction.....	33
4.1.1.LED Indicators.....	33
4.1.2.Audible Alarm (Buzzer).....	34
4.1.3.LCD and Functional Keys.....	34
4.1.4.LCD Menu Structure.....	35
4.2 LCD Screen Types.....	35
4.2.1.Start-up Screen	35
4.2.2.Flow Screen.....	36
4.2.3.Main Menu Screen.....	36
4.2.4.Submenu Screen.....	37
4.2.5.Default Screen.....	41
4.3 Prompt Window.....	41
4.4 UPS Alarm Message List.....	44

5 UPS Operating Instructions	49
5.1 Brief Introduction	49
5.1.1.Precautions.....	49
5.1.2.Power Switch.....	49
5.1.3.Check before Start-up.....	50
5.2 UPS Start-up Procedures	50
5.2.1.Start-up Procedures in Normal Mode.....	51
5.2.2.Start-up Procedures in Battery Mode (Battery Cold Start).....	53
5.3 Procedures for Transferring between Operating Modes.....	53
5.3.1.Transfer from Normal Mode to Battery Mode.....	53
5.3.2.Transfer from Normal Mode to Bypass Mode.....	53
5.3.3.Transfer from Bypass Mode to Normal Mode	54
5.3.4.Transfer from Normal Mode to Maintenance Bypass Mode.....	55
5.3.5.Transfer from Maintenance Bypass Mode to Normal Mode	56
5.4 Battery Test Procedures.....	56
5.5 System Test Procedure	57
5.6 UPS Shutdown Procedures	58
5.6.1.Procedures for Completely Powering down UPS	58
5.6.2.Procedures for Completely Powering down UPS while Maintaining Power to Load.....	58
5.7 EPO.....	58
5.8 UPS Reset Procedures after EPO.....	59
5.9 Automatic Restart.....	59
5.10 Selecting Language.....	60
5.11 Changing Current Date and Time.....	61
5.12 Setting Password.....	63
6 Parallel System and LBS System.....	67
6.1 General.....	67
6.2 Requirements.....	67
6.3 System Installation Procedures.....	67
6.3.1. Preliminary Checks	68
6.3.2.Cabinet Installation	68
6.3.3.Power Cables.....	69

6.3.4. Parallel Cables.....	69
6.3.5.Remote EPO.....	69
6.4 Operation Procedures for Parallel System.....	70
6.4.1.Check before Start-up	70
6.4.2.Parallel System Parameters Setting.....	71
6.4.3.Power-on Procedures for Parallel System.....	71
6.4.4.Maintenance Bypass Procedures.....	72
6.4.5.Procedures for Isolating One UPS Module from Parallel System.....	73
6.4.6.Procedures for Inserting One Isolated UPS Module in Parallel System.....	73
6.4.7.6.4.7 Procedures for Completely Powering down UPS.....	74
6.4.8.Procedures for Complete UPS Shutdown while Maintaining Power to Load.....	74
6.5 LBS System.....	74
6.5.1.Overview	74
6.5.2.Cabinet Installation	74
6.5.3.Connecting Power Cables.....	76
6.5.4.Connecting LBS Cables	76
6.5.5.LBS Parameters Setting.....	76
6.5.6.LBS System Commissioning.....	76
7 Communication.....	77
7.1 Installing Intelligent Card.....	77
7.1.1.Intelligent Card Port.....	77
7.1.2.Intelligent Card Option.....	78
7.1.3. Installation Procedures.....	81
7.2 Connection Cables for Dry Contact Port.....	82
7.3 Connecting Parallel Cables	85
7.4 Connecting LBS Cables.....	85
8 Maintenance.....	87
8.1 Fan Maintenance.....	87
8.2 Battery Maintenance.....	87
8.3 Cleaning UPS.....	88
8.4 Checking UPS State.....	88
8.5 Checking UPS Functions	88

9 Options.....	89
9.1 List of Options.....	89
9.2 Parallel Cables	90
9.3 LBS Cables.....	90
9.4 Communication Options and Temperature Sensor.....	91
9.5 BCB Box	92
9.5.1.Overview	92
9.5.2.Connection of BCB Box	93
9.6 Battery Cabinet.....	94
9.7 Output Transformer.....	96
9.8 Top Fan.....	97
9.9 IP31 Kit.....	98
9.10 C2 Electromagnetic Shielding Assembly.....	98
10 Specifications	99
10.1 Conformance and Standards	99
10.2 Environmental Characteristics	99
10.3 Mechanical Characteristics.....	100
10.4 Electrical Characteristics (Input Rectifier).....	100
10.5 Electrical Characteristics (Battery).....	100
10.6 Electrical Characteristics (Inverter Output).....	101
10.7 Electrical Characteristics (Bypass Input).....	101
Appendix I LCD Parameters Setting.....	103
Appendix II Glossary.....	109
Appendix III Hazardous Substances and Content.....	110

This page is intentionally left blank.

Special Declaration

Personnel Safety

1. This product must be installed and commissioned by professional engineers of the manufacturer or its authorized agent. Failure to observe this could result in product malfunction or personnel safety risk.
2. Take the time to read this product manual and the safety precaution thoroughly before installing and commissioning this product. Failure to observe this could result in product malfunction or personnel safety risk.
3. This product is not intended for life support equipment application.
4. Never dispose of the internal or external battery of this product in a fire, as it may explode and jeopardize personnel safety when exposed to flame.

Product Safety

1. If this product will be stored or remain de-energized for a long period, it must be placed in a dry and clean environment within specified temperature range.
2. This product should be used in an appropriate operating environment. For details, refer to the section on the environmental requirement in this manual.
3. This product is not designed for application in an environment:
 - Where the temperature and relative humidity are outside the specifications
 - Subject to vibrations or shocks
 - Where conductive dusts, corrosive gases, salts, or flammable gases are present
 - Near heat sources or strong electromagnetic interferences

Disclaimer

Vertiv disclaims any and all responsibility or liability for the defects or malfunction caused by:

- Application range or operating environment outside the specifications
- Unauthorized modification, improper installation or operation
- Force majeure
- Other actions not in compliance with the instructions in this manual

Safety Precaution

This manual contains information concerning the installation and operation of the Liebert EXS 80kVA UPS.

Read this manual thoroughly before installing, using and servicing the UPS.

To reduce the chance of accident, please read the safety precautions very carefully before operation. The 'Caution, Note, Warning' in this user manual and on the product do not represent all the safety points to be observed, and are only supplement to various safety points. Therefore, the installation and operation personnel must receive strict training and master the correct operations and all the safety points before operation.

When operating Vertiv products, the operation personnel must observe the safety rules in the industry, the general safety points and special safety instructions provided by Vertiv.



IMPORTANT! 1. The UPS must be installed, commissioned and serviced by engineers designated by the manufacturer or its agent. Failure to observe this could result in personnel safety risk, UPS malfunction and invalidation of warranty.

2. The UPS has been designed for commercial and industrial use only, and is not recommended for use in life support applications.



WARNING! This is a product for commercial and industrial application in the second environment installation restrictions or additional measures may be needed to prevent disturbances.

The UPS with standard configuration is a category C3 product. Installation restrictions or additional measures may be needed to prevent disturbances. The UPS adding C2 EMC option based on the standard configuration is a category C2 product for a residential environment or commercial and industrial application in the second environment.



Conformity and standards 1. The UPS complies with 2014/35/EU (LVD), 2014/30/EU (EMC), 2011/65/EU (Rohs) and the following product standards for UPS:

- IEC/EN 62040-1, General and safety requirements for UPS
- IEC/EN 62040-2: Class C2 compliant
- EC/EN 62040-3: Performance requirements and test methods

2. Continued compliance requires installation in accordance with these instructions and the use of manufacturer approved accessories only.



WARNING! 1. Before moving or rewiring the UPS, disconnect mains input power and the battery and make sure that the UPS is completely shut down. Otherwise, the output terminal may carry live voltage, presenting an electric shock hazard.

2. Liquid or other irrelevant external objects are prohibited inside the UPS.

3. In case of a fire, a dry chemical fire extinguisher is essential. Using a foam fire extinguisher will cause electric shock.

4. To prevent the radio frequency of output cables from disturbing other electric equipment, it is recommended to use the UPS output cable with the length less than 10m.

**WARNING! High earth leakage current**

1. Earth connection is critical before connecting the input supply (including both mains supply and battery).
2. Earth leakage current is less than 2500mA.
3. Transient and steady state earth leakage currents, which may occur when the equipment is started, should be taken into account in the selection of instantaneous RCCBs or RCD devices. RCCB which is sensitive to unidirectional DC pulse (class A) and insensitive to transient state current pulse must be selected.
4. Note also that the earth leakage currents of the load will be carried by the RCCBs or RCDs.
5. The equipment must be earthed in accordance with the local electrical code of practice.

**WARNING! Backfeeding protection**

This UPS is fitted with a dry contact closure signal for use with an external automatic disconnect device (supplied independently) to protect against backfeeding voltage into the incoming terminal through the rectifier or bypass switch circuit. A label must be added at all external incoming primary supply disconnect device to warn service personnel that the circuit is connected to a UPS. The text of the label has the following meaning: Risk of voltage backfeed! Isolate the UPS, then check for hazardous voltage between all terminals including the protective earth before working on this circuit.

**User serviceable components (For service personnel)**

1. All equipment maintenance and servicing procedures involving internal access requires the use of a tool and should be carried out only by trained personnel. There are no user-serviceable parts behind covers requiring a tool/key for removal.
2. The UPS meets the safety requirements completely in operator access area. Only service personnel can contact the hazardous voltage inside the UPS. However, the risk of contacting these voltages is minimized because the components with hazardous voltage may be contacted only by using a tool to remove the protective cover. No risk will exist if you follow the general norms and in accordance with the procedures recommended in this manual on equipment operation.

**Battery voltage exceeds 400Vdc (For service personnel)**

1. All physical battery maintenance and servicing procedures requires the use of a tool and should be carried out only by trained personnel.
2. Operation on the battery will result in electric shock and high short-circuit current, therefore, before operating the battery, the following should be observed:
 - Remove the watches, rings and other metal objects.
 - Use the tools with insulation handle.
 - Wear rubber glove and shoes.
 - Avoid to place the tools and metal objects on the battery surface.
 - Cut off the charge power supply before connecting or disconnecting the battery terminals.
 - Check whether the battery is earthed accidentally, if yes, please disconnect the earthing. Contacting any earth battery parts will result in electric shock. Therefore, make sure that the battery is not earthed during installation and maintenance.
3. Battery manufacturers provide the details of the precautions to be observed when working on, or in the vicinity of the batteries. These precautions should be followed implicitly at all times. Attention should be paid to the recommendations concerning local environmental conditions and the provision of protective clothing, first aid and fire-fighting facilities.

**WARNING! 1. When selecting the UPS system upstream distribution protection equipment, ensure that it complies with the local electric regulations.**

2. When the internal fuse of the UPS is damaged, it must be replaced with fuse of the same electric parameters from the designated manufacturer, and operated by qualified personnel.

This page is intentionally left blank.

1 Overview

The Liebert® EXS 80 kVA UPS (UPS for short) is a monolithic transformer-free UPS which delivers reliable and high-quality AC power for mission critical application such as data centers, computers, communication systems, healthcare, railway, and process & automation equipments.

This chapter introduces the features, design concept, operating principle, UPS state and operation mode of the UPS.

1.1 Features

Features are as follows:

- Output power factor is up to 1
- Double conversion efficiency up to 96% and ECO mode efficiency up to 99
- Compact footprint with optional integrated isolation transformer
- Parallel up to 4units which delivers max capacity of 320 kVA
- Unity input power factor
- Tolerates wide range of input voltage i.e. 228 - 475 VAC without feeding battery backup power
- Flexible battery configuration: external battery (26 to 40-block)
- High capacity battery charger that delivers maximum charging current of 25 A
- Innovative air channel design improves reliability of the product
- Colorful LDC display panel to intuitively inform you about UPS operating status and operating parameters
- Features Eco mode and smart sleep mode functions, which helps to save the energy to the maximum extent
- Tolerates conditional short circuit current rating (Icc) of 30 kA symmetrical rms

1.2 Design Concept

1.2.1 System Design

This section introduces the working principle of the UPS single module. The UPS adopts AC-DC-AC converter (as shown in Figure 1-1). The first stage conversion (AC-DC) adopts three-phase high frequency rectifier to convert the three-phase input voltage into stable DC bus voltage. The second stage conversion (DC-AC) adopts three-phase high frequency inverter to convert the DC power supply into the three-phase AC input voltage.

Figure 1-1 Block diagram for working principle of UPS single module

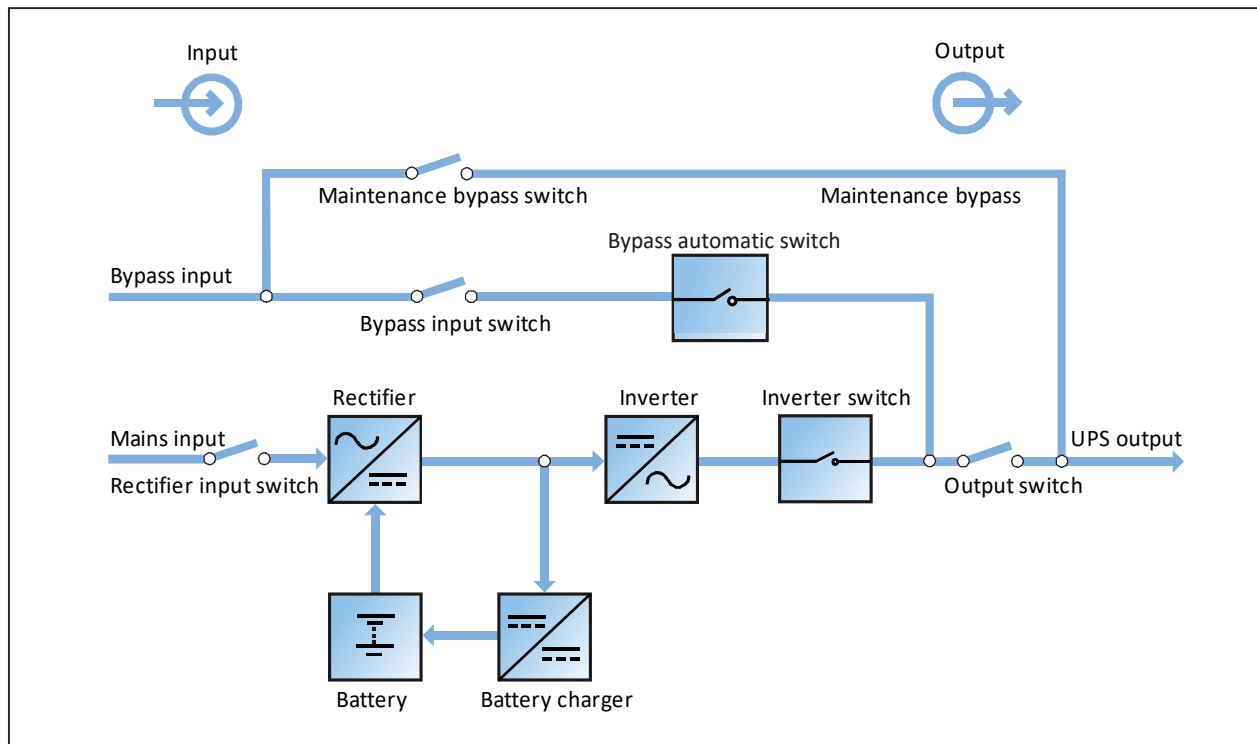

1. The UPS is composed of mains input (main and bypass), rectifier/PFC, charger, inverter, bypass, battery, and output.
2. When the mains is normal, the rectifier and inverter work together to supply the loads and charge the battery.
3. When the mains is abnormal, the rectifier/PFC circuit boosts the battery voltage and supplies it to the inverter. The inverter then converts it into pure sine wave AC power and supplies the AC power to the load. If the battery voltage falls to end of discharge (EOD) voltage and the mains still has not been recovered, the UPS will shut down (if the system uses split bypass configuration and the bypass is normal, the system will transfer to bypass). The battery EOD voltage is preset. When the mains is abnormal, the battery maintains the UPS operation till the battery voltage is reduced to EOD voltage and the UPS shuts down, this time is called 'Backup Time'. The length of backup time depends on the battery capacity and the loads.
4. After the mains returns to normal state, the UPS will automatically transfer from Battery mode to Normal mode, and the rectifier and inverter work together to supply the loads and charge the battery.

1.2.2 Bypass

Through the intelligent control of the 'Bypass Automatic Switch' (as shown in [Figure 1-1](#)), the loads can be supplied by the inverter or the bypass. In normal situation, the loads are supplied by the inverter, in which case the automatic inverter switch at inverter side is closed. In the case of overload (the overload delay time expires) or inverter failure, the automatic inverter switch is opened, and the ' Bypass Automatic Switch ' module will automatically transfer the loads to the bypass.

In normal operating state, to realize the uninterrupted transfer between inverter and bypass, the inverter output must be fully synchronized with the bypass.

Therefore, when the bypass frequency is within the synchronization range, the inverter control circuit will synchronize the inverter output frequency with the bypass frequency and phase.

Besides, the UPS has a manual maintenance bypass switch for shutdown of the UPS upon maintenance. In this situation, the bypass will directly supply the critical loads through the maintenance bypass.

NOTE: When the load is supplied by the bypass or maintenance bypass, the power supply quality will be uncertain.

1.2.3 System Control Principle

Normal operation

Normal mode: It means that the UPS has normal input mains, the rectifier and inverter operate normally, the load is supplied by the inverter, the battery circuit breaker is closed, and the battery is in stable floating charge state.

(Parallel System) Note: As the UPS single module outputs are connected in parallel, the system checks that the inverter control circuits are perfectly synchronized with one another and with the bypass in terms of both frequency and phase, and that they have the same output voltages. Current supplied to the load is automatically divided among UPSs. A warning message appears while synchronization is in progress.

Mains abnormal

When the mains fails or is abnormal, the rectifier will stop working automatically, and the system will transfer to battery output (through inverter). The length of the operation time in battery mode depends on the load and the battery capacity. During this period, if the battery voltage falls to the EOD voltage and the mains still has not been recovered, the inverter will stop working automatically, and the UPS operator control and display panel will display corresponding alarm messages. If the system uses split-bypass configuration and the bypass is normal, the system will transfer to bypass.

Mains recovery

When the mains resumes normal within allowable time, the rectifier will start automatically and supply the load and charge the battery again. Therefore, the power supply to the load will not be interrupted.

Battery disconnection

To disconnect the external battery from the UPS system for maintenance, use the external isolating switch. At this time, except for the battery backup function upon mains failure, other functions and all the steady state performance of the UPS will not be affected.

UPS module failure

In case of inverter failure and output fuse blowout, the load will automatically transfer to the bypass, and the output power supply will not be interrupted. In this situation, please contact the local customer service center of Vertiv for technical support.

(Parallel System) In the event of a fault in a UPS module, it will automatically exit from the parallel system. If the system is still capable of providing the required load, the remaining modules will continue to supply the load with no interruption. If the remaining modules are no longer capable of fulfilling the power requirements, the load will automatically transfer to the bypass.

Overload

If the inverter is overloaded or the inverter current remains outside the specifications longer than the specified time, the load will automatically transfer to the bypass without power interruption. If both the overload and the current are reduced to a level within the specified range, then the load will be transferred back to the inverter. In case of output short circuit, the load will be transferred to the bypass, and the inverter will shut down. Five minutes later, the inverter will start up automatically. If the short circuit is removed at this point, the load will be transferred back to the inverter. The transfer is determined first of all by the features of the protective device of the system.

In the above two situations, the UPS operator control and display panel will display alarm messages.

(Parallel System) The control logic system constantly monitors load requirements and controls the power supplied by each UPS module. In the event that an overload condition is sustained for greater than a preset time, the load will transfer to the bypass, when the number of active modules is unable to satisfy load requirements. The load returns to the inverter if the power is reduced to a value that can be sustained by the number of active modules in the system.

Maintenance bypass

The UPS has a second bypass circuit, i.e. maintenance bypass, which provides a safe working environment for the engineers to provide regular maintenance or repair to the UPS system and at the same time provide unregulated mains supply to the loads. The maintenance bypass can be manually selected through the maintenance bypass switch, and it can be disconnected by turning the switch to OFF.



WARNING: If the UPS system is composed of two or more UPS modules, and when the load capacity exceeds the single module capacity, do not use the internal maintenance bypass switch.

1.2.4 UPS Power Supply Switch Configuration

The UPS has four switches: rectifier input switch Q1, bypass input switch Q2, maintenance bypass switch Q3, output switch Q5.

Figure 1-2 describes the block diagram of the UPS module. The UPS is available in split bypass configuration (that is, the bypass adopts independent mains input) and common input configuration. If the system adopts common input configuration, the UPS has copper shorting bar of common input configuration, and the bypass input switch (Q2) and rectifier input switch (Q1) would be linked together. If the system adopts split bypass configuration, just remove the copper shorting bar of common input configuration of the UPS.

During the normal operation of the UPS, except for the maintenance bypass switch Q3, other switches shall be closed.

Figure 1-2 UPS power supply switch configuration

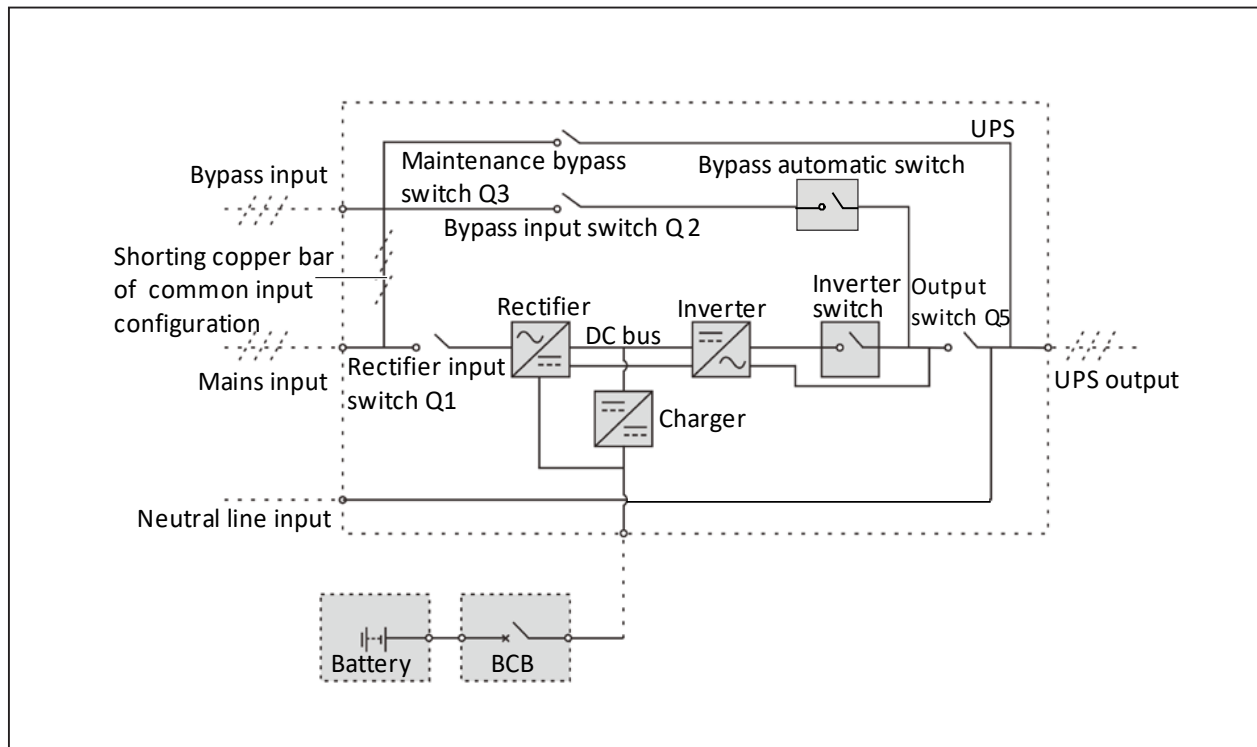

NOTE: The mains input and bypass input share the same neutral line.

1.2.5 Battery Circuit Breaker (BCB)

The external battery shall be connected to the UPS through the BCB. The BCB box is an option, which shall be installed near the battery. The BCB is closed manually, and has a shunt tripping coil. When the system is faulty and the BCB needs to be disconnected, the UPS control circuit will send a signal to the shunt tripping coil so as to trip the BCB. It also has a magnetic trip facility for overload protection and short circuit protection.

1.3 Parallel System

Up to four UPS modules can be connected in parallel to increase the system capacity and reliability. The load is equally shared between the paralleled UPS modules.

Moreover, two UPS modules or parallel system can comprise a dual bus system. Each parallel system has independent output. Output synchronization is achieved through the LBS cable or LBS device, thus enabling seamless load transfer between the two parallel systems through the STS device.

1.3.1 Parallel System Features

1. The hardware and software of parallel system are completely the same as those of the single module. The parallel system configuration is achieved through settings in configuration software.
2. Parallel cables are connected in a ring, providing both system reliability and redundancy.
3. The total load of the parallel system can be queried from the LCD of each UPS.

1.3.2 Parallel System Requirements

A group of paralleled modules behave as if it were one large UPS with the advantage of presenting higher reliability. To ensure that all modules are equally utilised and to comply with relevant wiring rules, the following requirements apply:

1. All UPS modules must be the same series, and connect to the same bypass source.
2. The N line of bypass and rectifier input sources must be connected to the same neutral line terminal.
3. Any RCD, if installed, must be of an appropriate setting and located upstream of the common neutral line input terminal. Alternatively, the device must monitor the protective earth current of the system. Refer to [WARNING! High earth leakage current](#).
4. For parallel system consists of two or more UPS modules, the bypass load sharing inductors (optional) should be selected.

1.4 UPS States and Operating Modes

For the LED indicators introduced in this section, refer to [4.11. LED Indicators](#).

The operating modes are as follows:

- Normal mode
- Battery mode
- Bypass mode
- Maintenance bypass mode
- ECO mode
- Parallel redundancy mode (system expansion)
- Frequency converter mode
- LBS mode

Normal mode

When the mains input is normal, the load is supplied with voltage-stabilizing and frequency-stabilizing power by the mains after processing of the rectifier and the inverter, and meanwhile, the charger is charging the battery. The operation mode is Normal mode.

In Normal mode, the run indicator (green) is on, the alarm indicator is off, and the buzzer is silenced.

Figure 1-3 Schematic diagram of normal mode

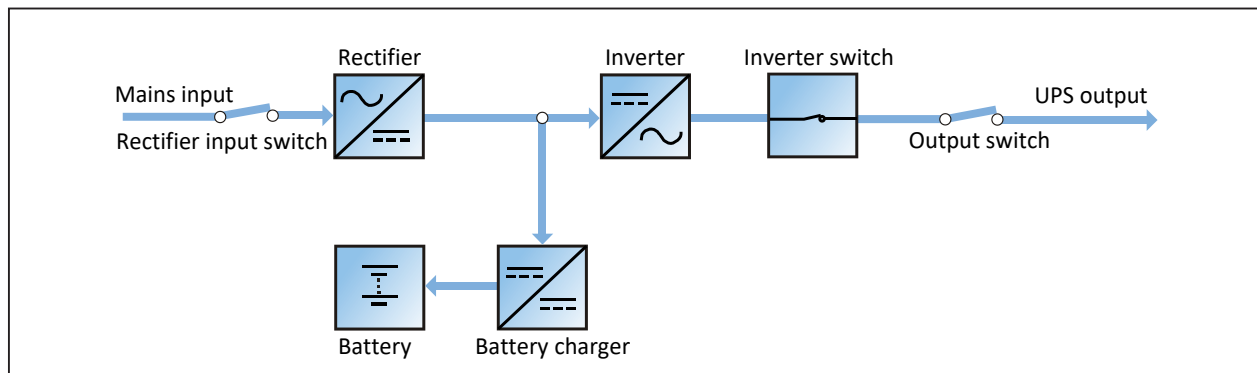

Battery mode

Upon mains failure or voltage out of range, the rectifier and internal charger will stop running, and the battery will supply power to the load through the inverter. When the mains is recovered, the system will automatically transfer back to the normal mode without any manual intervention, and the power to the load will not be interrupted.

In Battery mode, the run indicator (green) is on, alarm indicator (yellow) is on, and the buzzer beeps every second. The 'Current' page in LCD will display 'On Battery'.

- NOTE: 1. The battery has been fully charged before delivery. However, some loss of capacity is inevitable during transportation and storage. Therefore, it is important to charge the battery for eight hours before putting the UPS into operation for the first time, to ensure it can provide adequate backup time.**
- 2. The Liebert EXS UPS supports cold start function, while this function is activated, UPS can be powered using battery mode without availability of input power supply. Therefore, the battery power can also be utilized independently for improving the system availability.**

Figure 1-4 Schematic diagram of battery mode

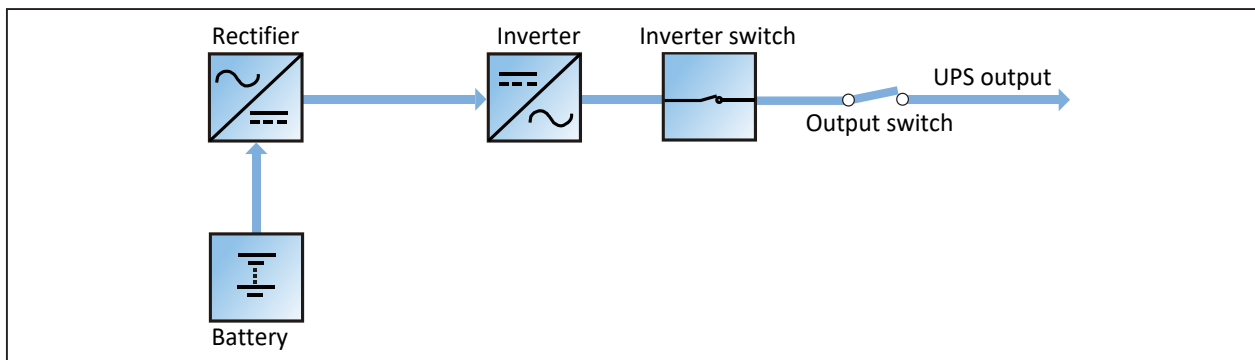

Bypass mode

If the overload overtime, inverter or rectifier failure appears during the UPS operation in Normal mode, the UPS will transfer to Bypass mode, that is, the load is powered by the bypass source, which comes directly from the mains input. If the rectifier is normal, the internal charger will charge the battery.

In Bypass mode, the run indicator (green) is on, alarm indicator (yellow) is on, and the buzzer beeps every second. The 'Current' page in LCD will display 'On Bypass'.

Figure 1-5 Schematic diagram of bypass mode

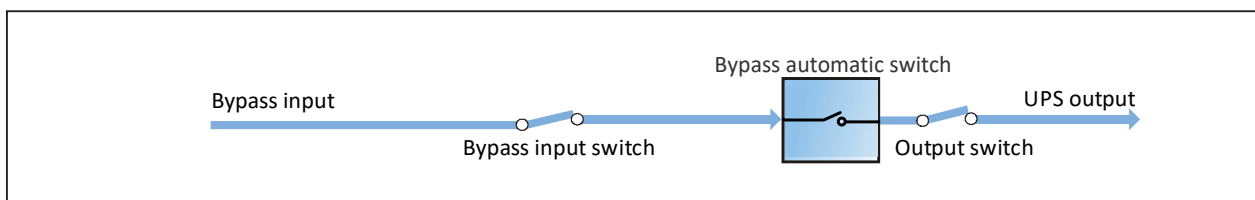

NOTE: In the event of a mains failure or if the mains voltage is outside tolerance while the UPS is in Bypass mode, the UPS will shut down and the power supply to the load will be interrupted.

Maintenance Bypass mode

If the UPS maintenance or service is required, you may use the manual maintenance bypass switch to transfer the load to maintenance bypass, with no interruption in power to the load. This maintenance bypass switch is fitted in all UPS modules and rated for full load of a single module.

Figure 1-6 Schematic diagram of maintenance mode

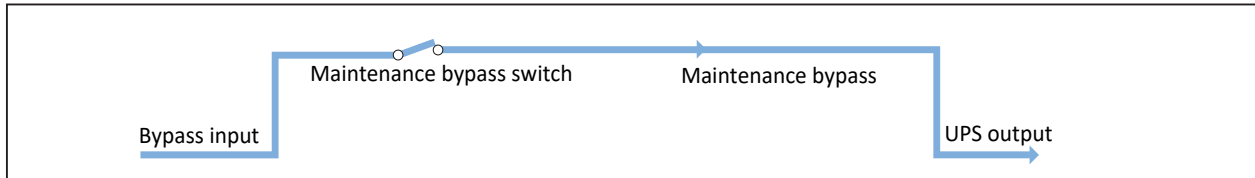

NOTE: In the event of UPS malfunctions or abnormal operation, contact your nearest Vertiv branch office or local service center. NEVER attempt to repair the UPS yourself, as this may result in injury to personnel and/or damage to equipment.

ECO mode

If ECO mode is selected, all power switches and the battery switches are closed except for the maintenance bypass switch, and the system prefers to put the load on the bypass, to achieve the aim of energy-saving. When the bypass supply is within the range of normal frequency and normal voltage (adjustable), the load is powered by the bypass, with the inverter on stand-by; when the voltage and/or frequency of the bypass supply are beyond the pre-defined and adjustable limits, the system will transfer to the inverter output, and the transfer time for switching from bypass to inverter is less than 4ms. In this mode, the system can normally charge the battery.

ECO mode is an energy-saving operating mode. When using the UPS to supply equipment that is no sensitive to mains power quality, ECO mode may be used to reduce power losses.

Figure 1-7 Schematic diagram of ECO mode

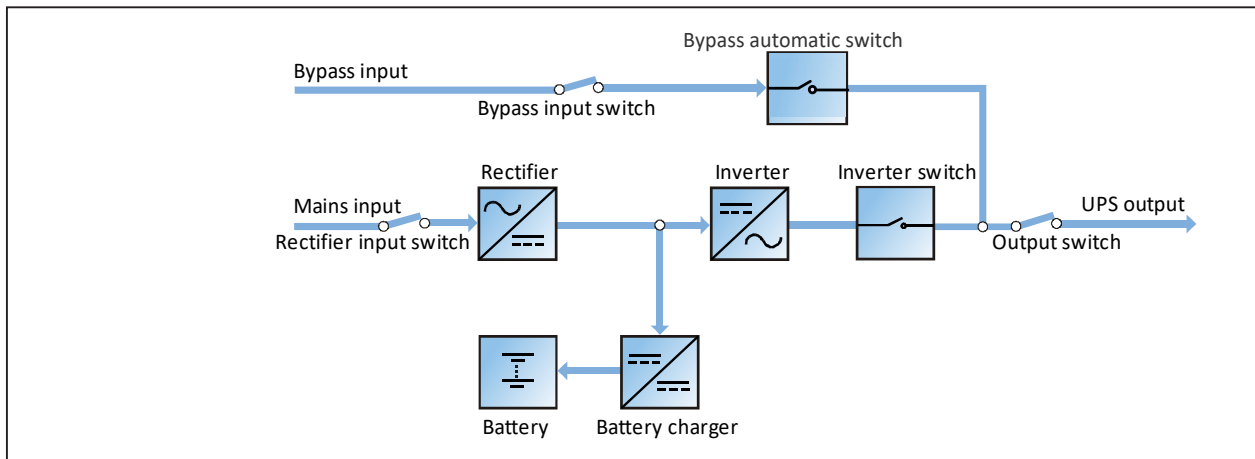

NOTE: 1. In ECO mode, if the bypass fails or the bypass voltage goes outside normal limits, the UPS will transfer to Normal mode (providing the output is not overloaded). However, if the bypass fails or the bypass voltage goes outside normal limits while the output is overloaded, the UPS will not transfer to Normal mode, but will shut down the Bypass.

2. In ECO mode, the efficiency of the UPS is increased to 99%.

3. In ECO mode, the load is not protected against mains distortion.

Parallel redundancy mode (system expansion)

For higher capacity or higher reliability, the outputs of multiple UPS modules can be programmed for directly paralleling while a built-in parallel controller in each UPS module ensures automatic load sharing. The parallel system can be composed of up to four UPS modules. For the operation principle diagram of the parallel redundancy mode, see [Figure 6-1](#).

Frequency converter mode

The UPS can be programmed into frequency converter mode for either 50Hz or 60Hz stable output frequency. The input frequency may vary from 40 Hz to 70 Hz. Under this mode, it is required to open the maintenance bypass switch to disable the bypass operation, and the battery becomes optional depending on any requirement to operate in battery mode.

LBS mode

A dual bus system consists of two independent UPS systems, each containing one or more parallel UPS modules. The dual bus system has high reliability and is applicable to the load with multiple inputs. For single-input load, an STS can be installed to power the load. For the operation principle diagram of the LBS mode, see [Figure 6-4](#) and [Figure 6-5](#).

1.5 Battery Management

The following battery management functions are set by the service engineer through the Vertiv setting software.

1.5.1 Normal Function

1. Constant current boost charge

Adopt the constant current (within battery charging limit) to charge the battery. The function can be used for battery capacity fast recovery. The charge current can be set.

2. Constant voltage boost charge

Adopt the constant voltage to charge battery. The function can be used for battery capacity fast recovery. For VRLA batteries, the maximum boost charge voltage should not exceed 2.4V/cell.

3. Float charge

The charging method is used for keeping battery with a full capacity. The float charge voltage is generally low. The function can balance the capacity loss due to battery self-discharging, and can be used for battery capacity recovery.

For VRLA batteries, the float charge voltage should be between 2.2 V/cell and 2.3 V/cell.

4. Automatic transfer to float charge

When the charge current is less than 'Threshold of Equalize Charge to Float Charge' or 0.5A, the charger will automatically transfer from boost charge to float charge. When boost charge time exceeds the limit of 'Equalize Charge Protect Time Limit', the charger will be forcibly transferred to float charge for protecting the battery.

5. Float charge temperature compensation (optional)

This function must be used together with the battery temperature detection device. The Vertiv battery temperature sensor is a standard option for your selection.

6. EOD protection

When the battery voltage drops to the EOD voltage, the battery converter shuts down automatically and the battery is inhibited to avoid further battery discharge. The EOD voltage is settable from 1.60 V/cell to 1.90 V/cell (VRLA).

7. Battery low pre-warning time

The battery low pre-warning time is adjustable between 3min and 60min. The default setting is 5 mins.

8. Maximum battery discharge time

When the battery has small current discharge for a long time, the battery is over discharged and even has unrecoverable damage, thus setting a battery discharge time to protect the battery is essential. The limit of time setting shall be configured by service engineer through the Vertiv setting software.

9. Maximum boost charge protection time

To protect against the battery overcharge damage caused by long time boost charge, a protect time setting is essential. The limit of time setting shall be configured by service engineer through the Vertiv setting software.

1.5.2 Advanced Function

The UPS provides battery maintenance test function. At periodic intervals, 20% of the rated capacity of the battery will be discharged automatically, and the actual three-phase load must exceed 20% of the nominal UPS capacity. If the load is less than 20%, the automatic discharge cannot be executed. The periodic interval can be set from 30 to 360 days. The battery maintenance test function can be disabled through the Vertiv setting software.

Conditions: Battery at float charge for at least 5h, load equal to 20% ~ 100% of rated UPS capacity.

Trigger: Automatically, or manually through the command of battery maintenance test in LCD.

Interval: 30 to 360 days (default setting: 60 days).

The UPS also provides battery capacity self-test function: Periodically test the battery activity, test the battery residual capacity, judge the battery quality, and then provide corresponding measures. The capacity self-test is started by the user through the operator control and display panel. During the capacity self-test, the battery will continuously discharge to the battery undervoltage shutdown threshold. After the self-test is finished, the system will update the battery curve table. The capacity self-test command is valid only one time, without any memory. During the capacity self-test, if the battery maintenance requirement is satisfied, the system will generate audible/visual alarm and give corresponding records.

Conditions: System load rate within 20% to 100%, battery float charge at least 5h, and generator not connected; the current system is in float charge state.

Trigger: Start up through the LCD.

NOTE: 1. The battery will continuously discharge to the battery undervoltage shutdown threshold, then the battery transfer to the charging state. When the capacity self-test is finished, the system will update the battery curve table.

2. The user can manually stop the capacity self-test operation through the LCD.

3. The battery capacity self-test needs to guarantee the discharge time not less than 6min, otherwise the battery self-learning time may be insufficient and the battery curve will not be updated.

1.5.3 Battery Temperature Compensation

The UPS system has battery charge temperature compensation function. When the ambient temperature is increased, the DC bus voltage (which charges the battery) will be reduced correspondingly to provide optimal float charging voltage for the battery, thus prolonging the battery service life time.

This function must be used together with the Vertiv battery temperature detection device (a standard option).

1.6 Battery Protection

The following battery protection functions are set by the service engineer through the Vertiv setting software.

Battery low pre-warning

The battery low pre-warning occurs before the EOD. After this pre-warning, the battery should have the capacity for three remaining minutes discharging with full load. The time can be configured from 3min to 60min.

EOD protection

When the battery voltage drops to the EOD voltage, the battery converter shuts down automatically. For VRLA batteries, the EOD voltage is adjustable from 1.60 V/cell to 1.90 V/cell (VRLA).

BCB alarm

The BCB alarm occurs when the external BCB opens, if you select the Vertiv BCB (optional).

The external battery connects to the UPS through the BCB. The BCB is manually closed and tripped by the UPS control circuit.

This page is intentionally left blank.

2 Mechanical Installation

This chapter briefly introduces the mechanical installation of the UPS, including the precautions, initial inspection before installation, environmental requirement, mechanical requirement and installation diagram.

2.1 Precautions

No two sites are the same, therefore this section provides general guidelines, procedures and methods for installation engineers, who shall adapt the installation to meet the actual conditions.



WARNING! Professional installation required

1. The UPS should be installed by a qualified engineer in accordance with the information provided in this section. In the event of any problems, contact your local Vertiv service center immediately.
2. The UPS must NOT be switched on without the approval of the commissioning engineer.
3. In the case of any equipment or items not covered by this section, refer to the specific mechanical and/or electrical installation instructions provided with such items.



WARNING! The UPS can be connected to IT (4-pole CB should be configured at upatream), TN and TT AC distribution systems (IEC60364-3), and must be of 3-phase 5-wire (A, B, C, N, PE) system.



WARNING! Battery danger

Take special care when installing batteries. When connecting batteries, the battery terminal generates DC high voltage, which is fatal to human being.

1. Please wear safety glasses to protect the eyes from being damaged by arc.
2. Remove all the metal items, including finger rings, watch, etc.
3. Use tools with insulated handle.
4. Wear rubber gloves.
5. If the battery has electrolyte leakage or the battery is damaged, it must be replaced. Place the battery into the container that can withstand sulfuric acid and dispose of it according to the local regulations.
6. If the skin contacts the electrolyte, flush it with water immediately.

2.2 Transportation

Railroad transportation and shipping are the recommended means of transportation. If truck transportation is unavoidable, choose roads that are less bumpy in order to protect the equipment.

The UPS cabinet is heavy (see [Table 10-3](#) for its weight). It is recommended to use mechanical equipment such as an electric forklift to unload and move the equipment to the place closest to the installation site. If an electric forklift is used, insert the tines of the forklift below the bottom pallet (as shown in [Figure 2-1](#)) to prevent the equipment from falling over.

- ! WARNING!** 1. DO NOT attempt to move the UPS by the brackets.
2. During transportation and installation, the product tilt angle shall not be greater than 15°.



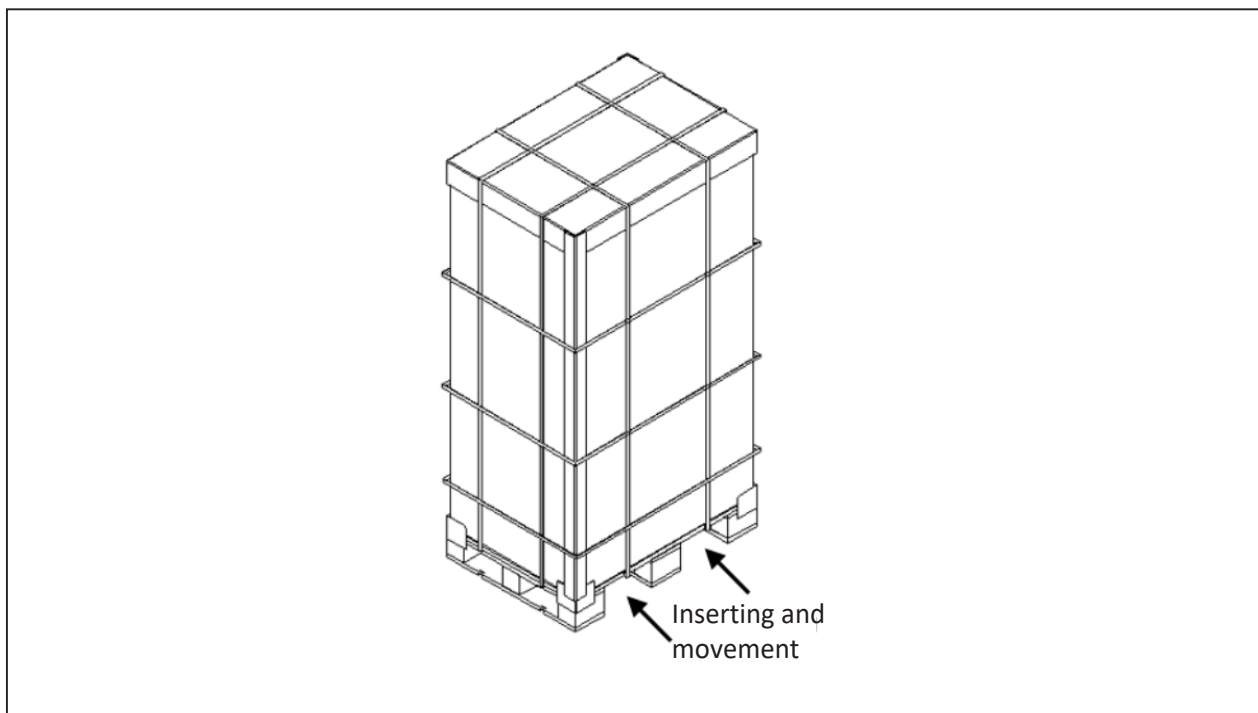

















Figure 2-1 Inserting and movement



2.3 Tools

- ! WARNING!** 1. For the sake of safety, the installation tools under live operation must be insulated.
2. Tools in [Table 2-1](#) are for reference only; please follow the actual requirement for on-site installation and connection.

Table 2-1 Tools

Name	Drawing	Name	Drawing
Electric hand drill		Adjustable wrench	
Slotted screwdriver		Cross head screwdriver	
Stepladder		Forklift	
Drill		Wire cutting plier	
Claw hammer		Diagonal cutting plier	
Insulating shoes		Antistatic gloves	
Electrician knife		Cable tie	
Insulating tape		Insulating gloves	
Crimping plier		Heat shrinkable tube	
Insulated torque wrench		Torque screwdriver	
Multimeter		Clip-on ammeter	

2.4 Unpacking

Unpack the UPS and battery packages under the guidance of authorized service engineer.

Steps:

1. Use a cutting plier to cut off the packing belt, and remove the honeycomb board, as shown in [Figure 2-2](#).

Figure 2-2 Removing packing belt and honeycomb board

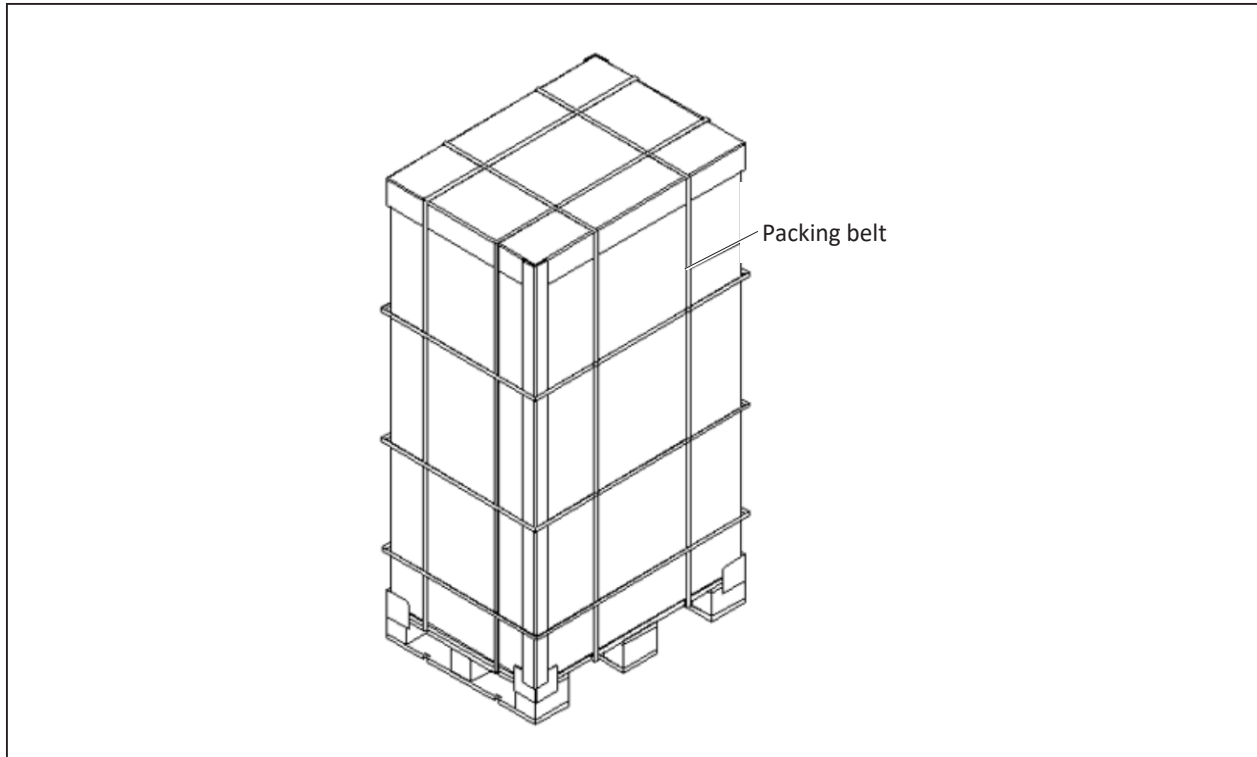

- As shown in [Figure 2-3](#), remove the carton (I, II, III), wrapping film, and protective cardboard at four corners.

Figure 2-3 Removing protective cardboard

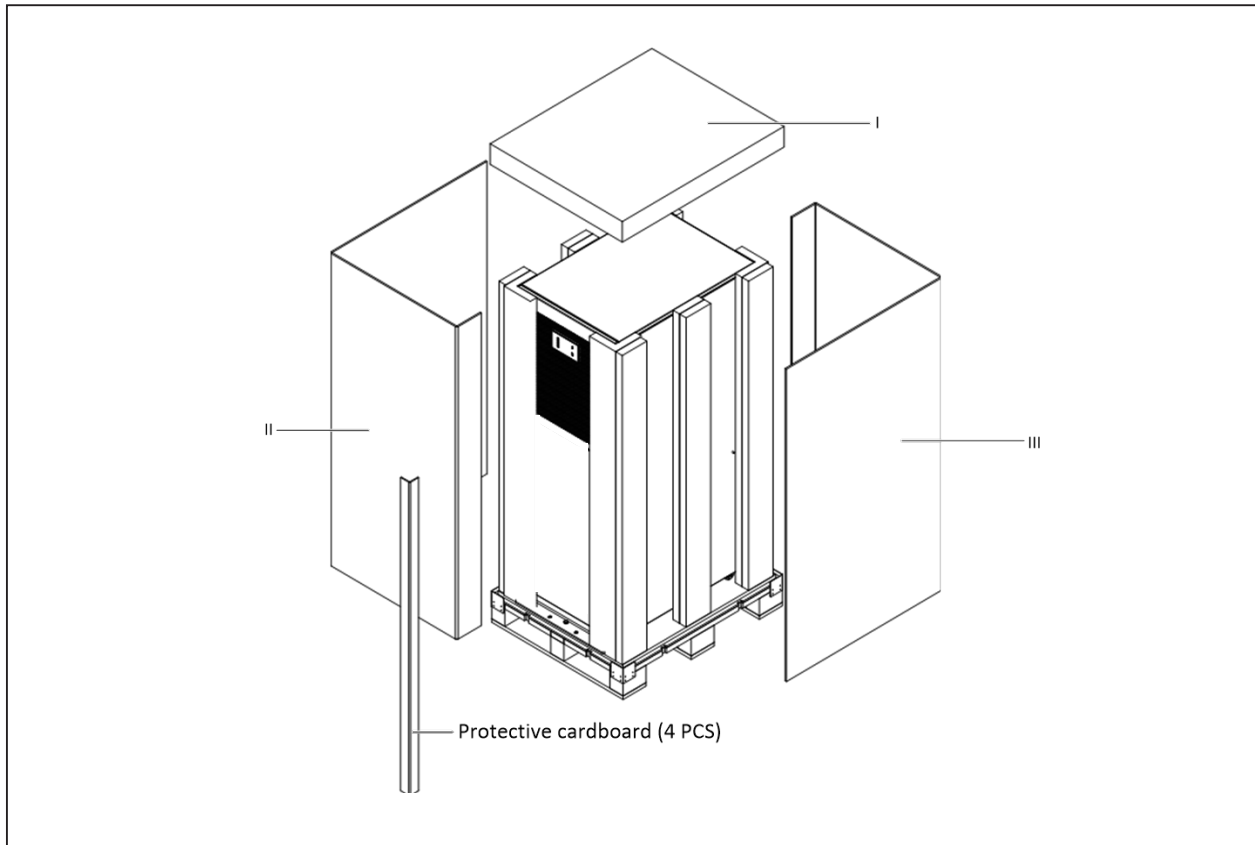

- Open the front panel, loosen the fixing screws and remove the bottom fixed part at front of the cabinet. Then loosen the fixing screws and remove the bottom fixed part at back of the cabinet. As shown in [Figure 2-4](#).

Figure 2-4 Removing bottom fixed part

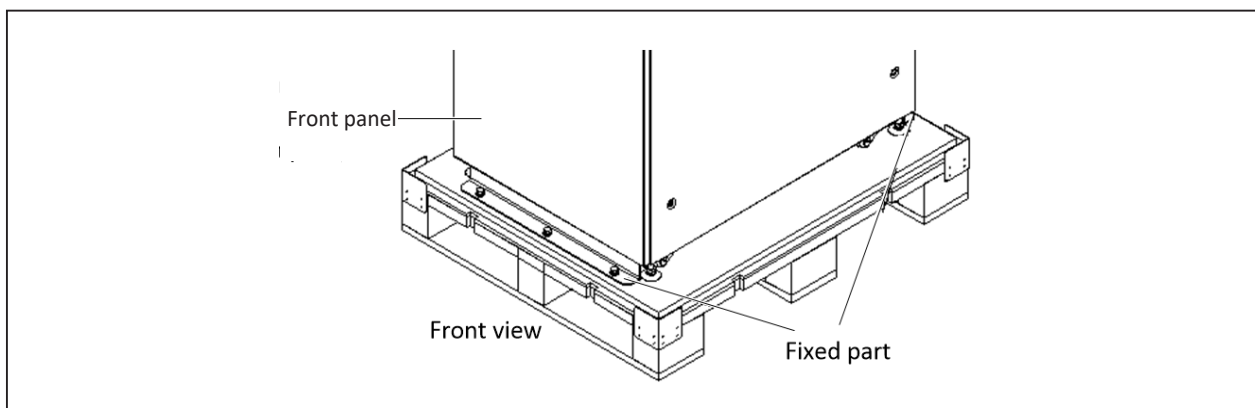

- Close the front panel. Raise the four feet, carry the cabinet using the forklift and move it to its installation position. Then lower the four feet to fix the cabinet.

2.5 Initial Inspection

Before installing the UPS, carry out the following inspections:

1. Ensure that the environment of the UPS equipment room meets the environmental requirement specified in the product technical specifications, especially the ambient temperature, ventilation conditions, and the dust situations.
2. Unpack the UPS and battery under the guidance of authorized service engineer. Visually inspect whether the UPS and battery have any transportation damage. If there is any damage, report to the carrier immediately.
3. Verify the UPS label and confirm the correctness of the UPS. The UPS label is attached on the back of the door. The model, capacity and main parameters of the UPS are marked on the label.

2.6 Environmental Requirements

2.6.1. UPS Room

The UPS should be located in a cool, dry, clean-air indoor environment with adequate ventilation, and should be located on concrete or other nonflammable and flat surfaces. The ambient environment should be free of conductive powder (such as metallic powder, sulfide, sulfur dioxide, graphite, carbon fiber, conductive fiber, etc.), acid mist or other conductive media (strongly ionized substances). The environment specifications should comply with relevant international standard & specifications and the operating range specified in this manual.

The UPS uses forced cooling by internal fans. Cooling air enters the UPS through the ventilation grills at the front of the cabinet and exhausted through the ventilation grills at the back of the cabinet. Do not obstruct the ventilation holes (ventilation grills). The front and rear of the UPS should be kept a distance at least 500 mm (see [Figure 2-5](#)) from the wall to avoid blocking the UPS heat dissipation, thus reducing the UPS internal temperature and improving the UPS life.

If necessary, install indoor extractor fans to aid cooling-air flow to avoid room temperature buildup. Air filters should be used when the UPS is to operate in a dirty environment.

2.6.2. Reserved Space

Figure 2-5 Installation clearances (top view)

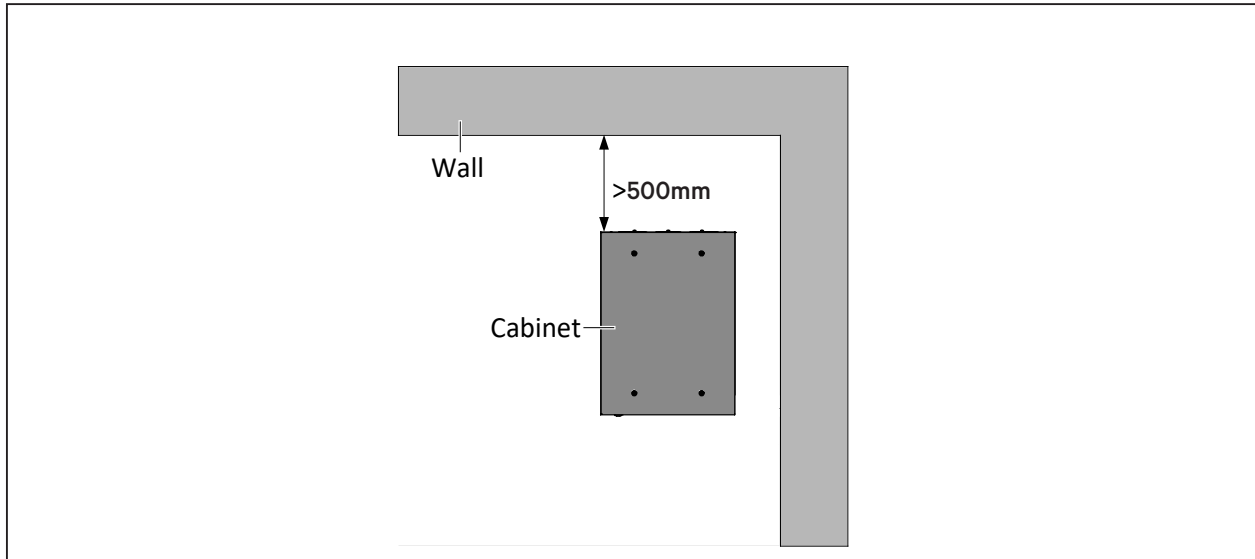

- NOTE:**
1. The UPS should only be installed on concrete or other non-inflammable surfaces.
 2. As shown in Figure 2-5, the clearance between the rear panel of the wall should be convenient. The clearance should not be less than 500mm, and should be sufficient to allow maintenance operations to be carried out.
 3. When the battery cabinet is installed near the UPS, the maximum allowable ambient temperature is dependent on the battery rather than the UPS.
 4. If the UPS is working in ECO mode, the power consumption will be less than that in Normal mode. Proper air conditioning system shall be selected according to the normal operating mode.

2.6.3. Battery Room

Batteries generate some amount of hydrogen and oxygen at the end of charge, so the fresh air volume of the battery installation environment must meet the EN50272-2001 requirements.

The ambient temperature is the main factor that affects the battery capacity and life. The normal operating temperature of the battery is 20 °C. If the ambient temperature is higher than 20 °C, the battery life will be reduced. If it is lower than 20 °C, the battery capacity will be reduced. In normal situation, the allowable ambient temperature for the battery is 15 °C to 25 °C. The ambient temperature of the battery shall be maintained constant, and the battery shall be kept away from heat source and air outlet.

When the UPS uses an external battery, you must install a protection device (such as fuse or circuit breaker) close to the battery, and keep the wiring distance between the battery and the protection device to a minimum.

2.6.4. Storage Environment

Should the UPS not be installed immediately, it must be stored with the original packaging in a room for protection against excessive humidity and heat sources. The battery needs to be stored in a dry and cool place with good ventilation. The most suitable storage temperature ranges from 20 °C to 25 °C.



WARNING! During the storage period, the battery must be charged at regular intervals, in accordance with the battery instructions. When charging the battery, you can connect the UPS to the mains temporarily to charge the battery and activate it.

2.7 Mechanical Requirements

2.7.1. Moving Cabinet



WARNING! 1. The lifting equipment for moving the UPS cabinet must have enough lift capacity. Refer to Table 10-3 for its weight.
 2. Due to its intensity, the castor may not be valid on the uneven surface.
 3. The center of gravity of the UPS cabinet is high; avoid falling over during the cabinet movement.
 4. Vertical hanging of cabinet is not allowed.
 5. During transportation and installation, the product tilt angle shall not be greater than 15°.



Caution: When carrying the UPS with batteries built-in, you must independently fasten each battery string and keep the moving distance to a minimum.

2.7.2. Clearance

Because the UPS has no grille at the two sides, there is no special clearance requirement on the two sides.

Besides the local regulations, to enable routine tightening of the power terminals within the UPS, it is recommended that clearance around the front of the UPS should maintain a clearance at least 1200mm. It is recommended that clearance around the rear of the UPS should maintain a clearance at least 500mm.

2.7.3. Cable Access Mode

For further description, refer to [3.1.8 Power Cable Connection Steps](#) and [3.2 Wiring of Signal Cable](#).

2.8 Installation Drawings

Figure 2-6 Top/front/side/bottom view of the 80kVA UPS (unit: mm)

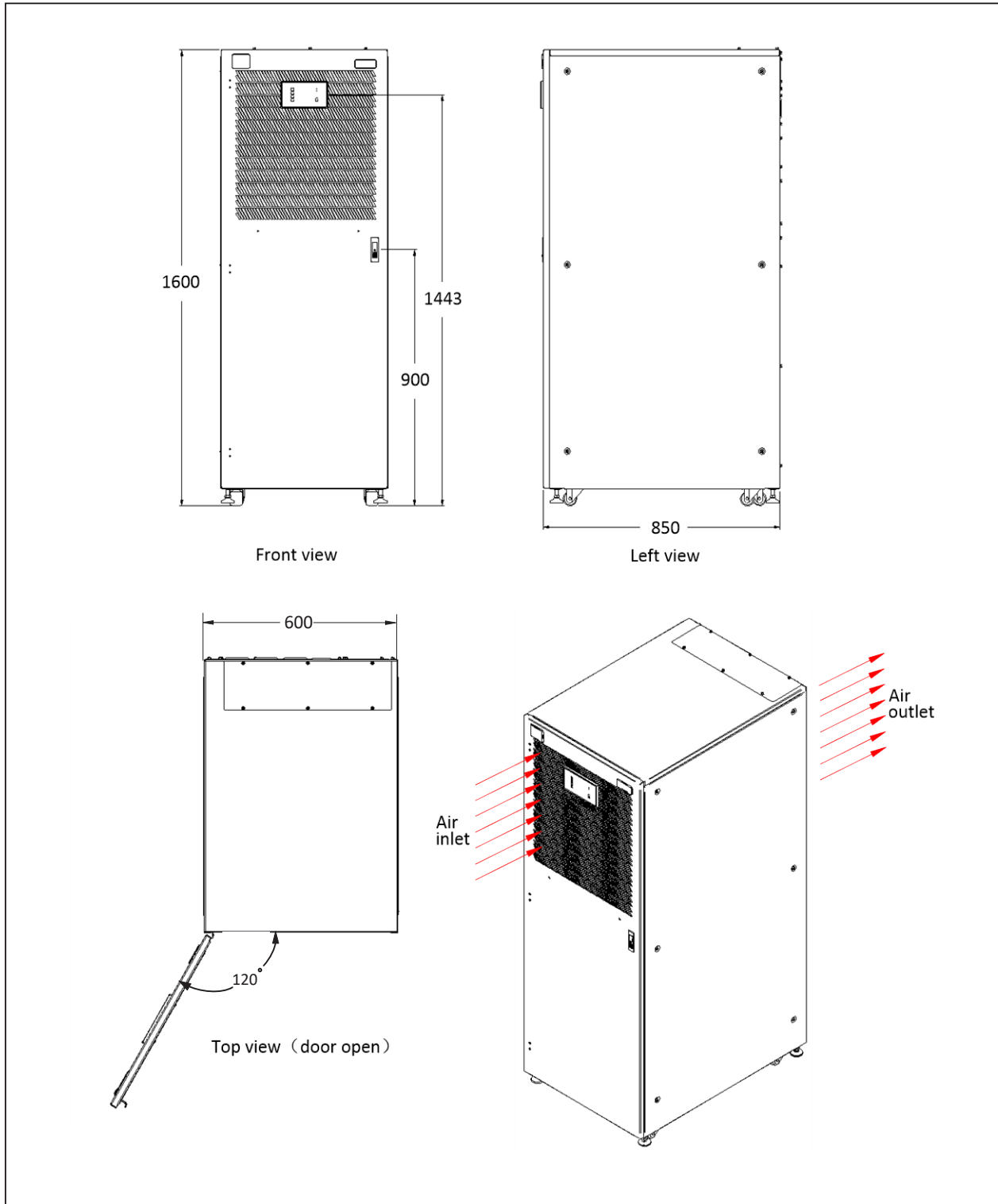

This page is intentionally left blank.

3 Electrical Installation

This chapter mainly introduces the electrical installation of the UPS, including the power cable and signal cable connecting procedures and methods.

After completing the mechanical installation of the UPS, it is required to connect the power cable and signal cable of the UPS. All the signal cables, whether shielded or not, shall be kept away from the power cables.



WARNING! 1. Do not power on the UPS before the arrival of authorized service engineer. 2. The UPS cables should be routed by an authorized engineer in accordance with the information contained in this chapter.

3.1 Wiring of Power Cable

3.1.1 System Configuration

The cable size of the system power cable shall meet the following requirements:

UPS input cable

The cable size of the UPS input cable differs with the UPS power ratings and input AC voltages, provided that it meets the requirement of maximum input current, including the maximum battery charge current, see [Table 3-1](#).

UPS bypass and output cable

The cable size of the UPS bypass and output cable differs with the UPS power rating and output AC voltages, provided that it meets the requirement of nominal output or bypass current, as shown in [Table 3-1](#).

Battery cable

Each UPS connects to its battery through the three cables connecting to the positive pole, negative pole and neutral line. The cable size of the battery cable differs with the UPS power ratings, provided that it meets the battery discharge current requirement when the battery discharges to near EOD voltage, as shown in [Table 3-1](#).

3.1.2 Maximum Steady State AC and DC Currents

The power cable must be selected according to the current and voltage values in [Table 3-1](#) as well as the local wiring regulations, and take environmental conditions (temperature and physical media) into consideration, then refer to Table 3B in IEC 60950-1.

Table 3-1 Max. steady state AC and DC currents

UPS power (kVA)	Max. input current ¹	Rated current (A)			Battery discharge current (+, -, N) at min. battery voltage ³	Stud bolt/nut specification	
		Output/bypass current ² at full load				Input/battery/output/	Recommended torque (N.m) of input/battery/output/bypass/PE
		380V	400V	415V			
80 kVA	160	121	116	111	277	M8/M10	6.0/10±5%

NOTE: 1. Max. input current is calculated according to the low-voltage input of 176V, 100% load percentage.

2. Max. output/bypass current is calculated according to the rated voltage, 100% load percentage.

3. The battery discharge current at the lowest battery voltage is calculated according to the battery cell number of 32, and lowest EOD voltage of 1.6V, 100% load percentage.

3.1.3 Recommended CSA of UPS Cable

The recommended CSA of the UPS cable is listed in [Table 3-2](#).

Table 3-2 Recommended CSA of the UPS cable (unit: mm², ambient temperature: 35 °C)

Model	Input	Output	Bypass	Neutral line	Earth cable	Battery
80 kVA	50	35	35	35*2	50	35*2

NOTE: 1. If the user's cable CSA exceeds the value recommended in [Table 3-2](#), or the harder cable installation is difficult, please contact Vertiv service engineers.

2. The soft cable with multi-core is recommended for convenient wiring and installation.

3.1.4 Selection of UPS I/O Switch

[Table 3-3](#) is the recommended UPS I/O switch capacity, and the user can select it according to actual needs.

Table 3-3 Recommended UPS I/O switch capacity

Model	Rectifier input switch	Bypass input switch	Output switch	Maintenance bypass switch
80 kVA	160 A (3P), isolating switch	160 A (3P), isolation switch	250 A (4P), isolating switch	160 A (3P), isolating switch

NOTE: 1. The switch of UPS module is an isolation switch by default. To prevent UPS fault from spreading to the upstream of customers, it is recommended to input a separate switch to the UPS according to the current value in [Table 3-1](#).

2. We recommend configuring Vertiv BCB box for the UPS with external batteries. If BCB is not selected, please select battery switch according to BCB parameters shown in [9.5 BCB Box](#).

3.1.5 Power Cable Connecting Terminal

The rectifier input, bypass input, output and battery power cables are connected to the corresponding terminals shown in [Figure 3-1](#).

3.1.6 Protection Ground

The protective earth cable is reliably connected to the PE input terminal (see [Figure 3-1](#)) via the fixing bolt. The PE terminal provides several holes for connecting input PE cable, output PE cable and external battery PE cable.

All the cabinets and cable troughs shall be grounded according to the local regulations. The grounding wires shall be tied up reliably to prevent the loosening of the grounding wire tightening screws when the grounding wires are pulled.



WARNING! Failure to ground as required may cause EMI, electric shock or fire risk.

3.1.7 Notes

The following points are for general guidance only. If there are relevant local regulations, the local regulations shall prevail.

1. The cable size of the protective earth cable shall be selected according to the AC power failure level, cable length and protection type. The grounding wire connection must use the shortest connection route.
2. For the cables with large current, parallel connection of small cables can be adopted to facilitate the installation.
3. When selecting the battery cable size, the current value in [Table 3-1](#) shall be referred to, and a maximum voltage drop of 4 Vdc is allowed.
4. Do not form coils, so as to minimize the formation of EMI.

3.1.8 Power Cable Connection Steps

Connection terminal and cable routing method

[Figure 3-1](#) shows the connection terminals, power cable entry and routing methods of the UPS power cable.



WARNING! Selecting internal battery and external battery at the same time is prohibited.

- NOTE:**
1. The power cables should be connected firmly and correctly.
 2. Add wire guard to the power cable to avoid unexpected damage.
 3. When routing the cables inside the cabinets, it is required to bind and fix the cables in the cabinets, so as to prevent cable damage due to mechanical stress.

Figure 3-1 Connection terminals and routing method of power cables

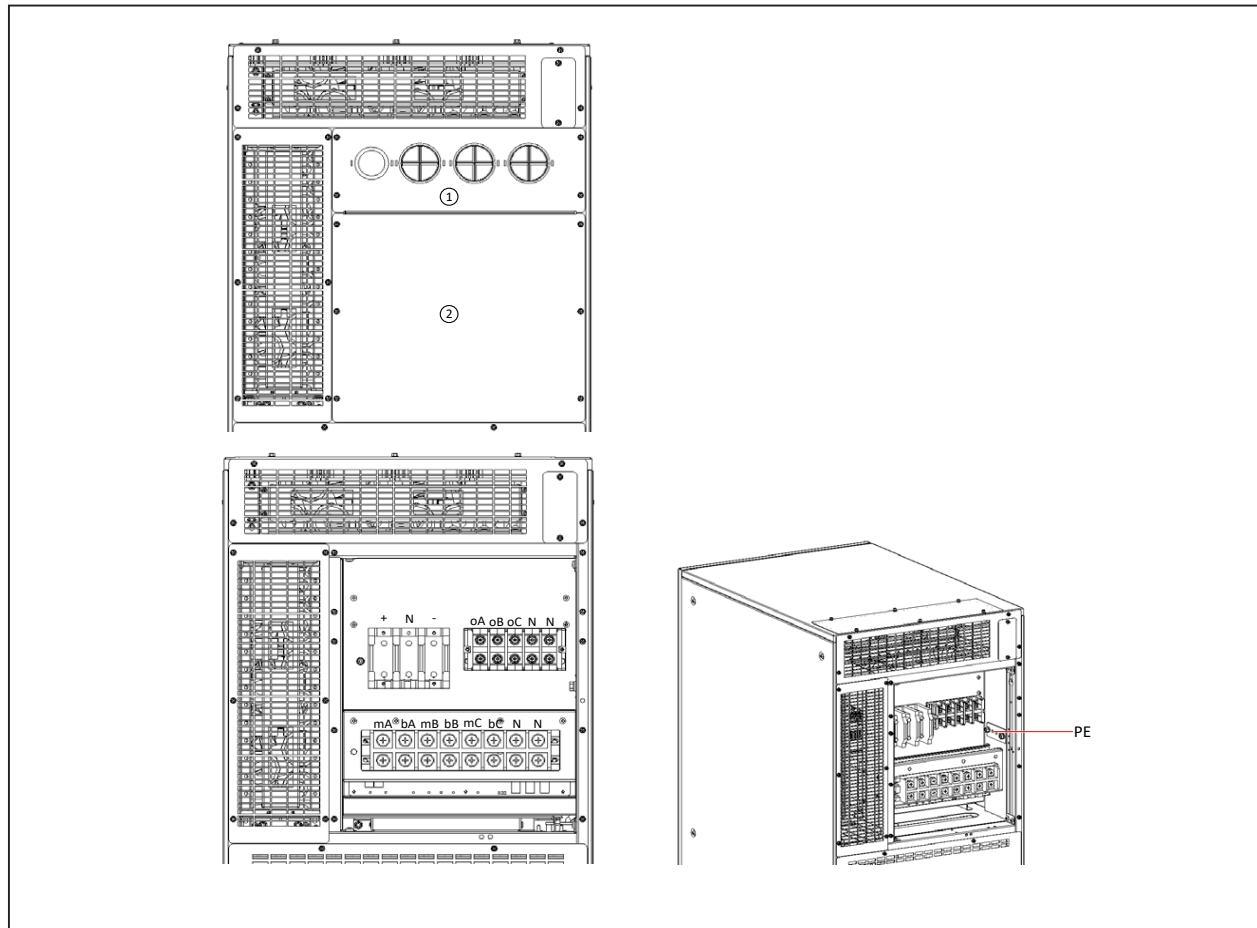

Procedures:

1. There are two protective covers at the rear of the cabinet. The user can use the cabling hole on No.1 protective cover for routing the cables according to actual needs.

NOTE: The guard ring or flange needs to be installed around the cabling hole so as not to cut the cables.

2. Dismantle the No.2 protective cover.
3. If split bypass configuration, just lead the main input cables (mA, mB, mC, N, PE), bypass input cables (bA, bB, bC, N, PE), and output cables (oA, oB, oC, N, PE) into the cabinet through corresponding cabling hole. Follow Figure 3-1 to connect power cables to corresponding terminals and fix PE cable to PE terminal. If common input configuration, just lead the main input cables (mA, mB, mC, N, PE), and output cables (oA, oB, oC, N, PE) into the cabinet through corresponding cabling hole.
4. If the user adopts external battery, just lead the battery cables into the cabinet through the reserved cabling hole at top of the routing area. Follow Figure 3-1 to connect power cables to corresponding terminals and fix PE cable to PE terminal.

Add wire guard to the power cable to avoid unexpected damage. Refer to Table 3-1 for torque value.

5. After confirming the cables connection is firm and correct, then reinstall the two protective covers at rear of the cabinet.

Now, the connection of power cables is complete.



WARNING! Before cables connection, make sure that all external and internal power switches of the UPS are off, and post necessary warning signs to prevent inadvertent operation of the switches. Meanwhile, measure the voltages between the UPS terminals and the voltages between the terminals and the earth.



WARNING! 1. The earth cables and neutral line must be connected in accordance with local and national codes of practice.
2. Failure to observe this could result in electric shock or fire risk.

Power distribution mode

Two modes are available for I/O cables: 3-in 3-out, common input configuration (default), 3-in 3-out, split bypass configuration.

Connection of system input

1. 3-in 3-out, common input configuration (default)

Connect the main input terminals (mA-mB-mC-N) and bypass input terminals (bA-bB-bC-N), and then parallel connect them to the main input terminals shown in Figure 3-1. Ensure correct phase rotation.

The shorting cables of common input configuration have been assembled before delivery, no need to reinstall them again.

2. 3-in 3-out, split bypass configuration

Remove the bypass input cables (bA-bB-bC) connected to the main input terminal. Connect the bypass input cables to the bypass input terminal (bA-bB-bC). Ensure correct phase rotation. Make sure that the main input cables ((mA-mB-mC) have been correctly and reliably connected to the main input terminal.

Connection of system output

Connect the system output cables between the output terminals (oA-oB-oC-N) in the cabinet and the load. Refer to [Table 3-1](#) for the torque value. Ensure correct phase rotation.



WARNING! If there is no requirement of power supply for the load before arrival of the service engineer, ensure that the system output cables are safely isolated at their ends.

Connection of batteries

If external batteries are required, ensure correct polarity of the connections from the battery string terminals to the BCB and from the BCB to the battery input terminals (+, N, -) in the UPS cabinet (see Figure 3-1), that is, (+) to (+) and (-) to (-), (N) to (N), and disconnect one or more battery cell links in each tier. Do not reconnect these links and do not close the BCB before authorized to do so by the service engineer.

NOTE: When connecting the cables between external battery terminals and BCB, the connection should begin from the BCB terminal.

3.2 Wiring of Signal Cable

NOTE: 1. Respectively route the power cables and signal cables. The shielding coat of signal cable must be reliably earthed.

2. Refer to 7.2 Connecting Dry Contact Port Cables for the definition of signal cables.

Refer to [Figure 3-2](#) for wiring of signal cable.

Figure 3-2 Wiring of signal cables (top cable access)

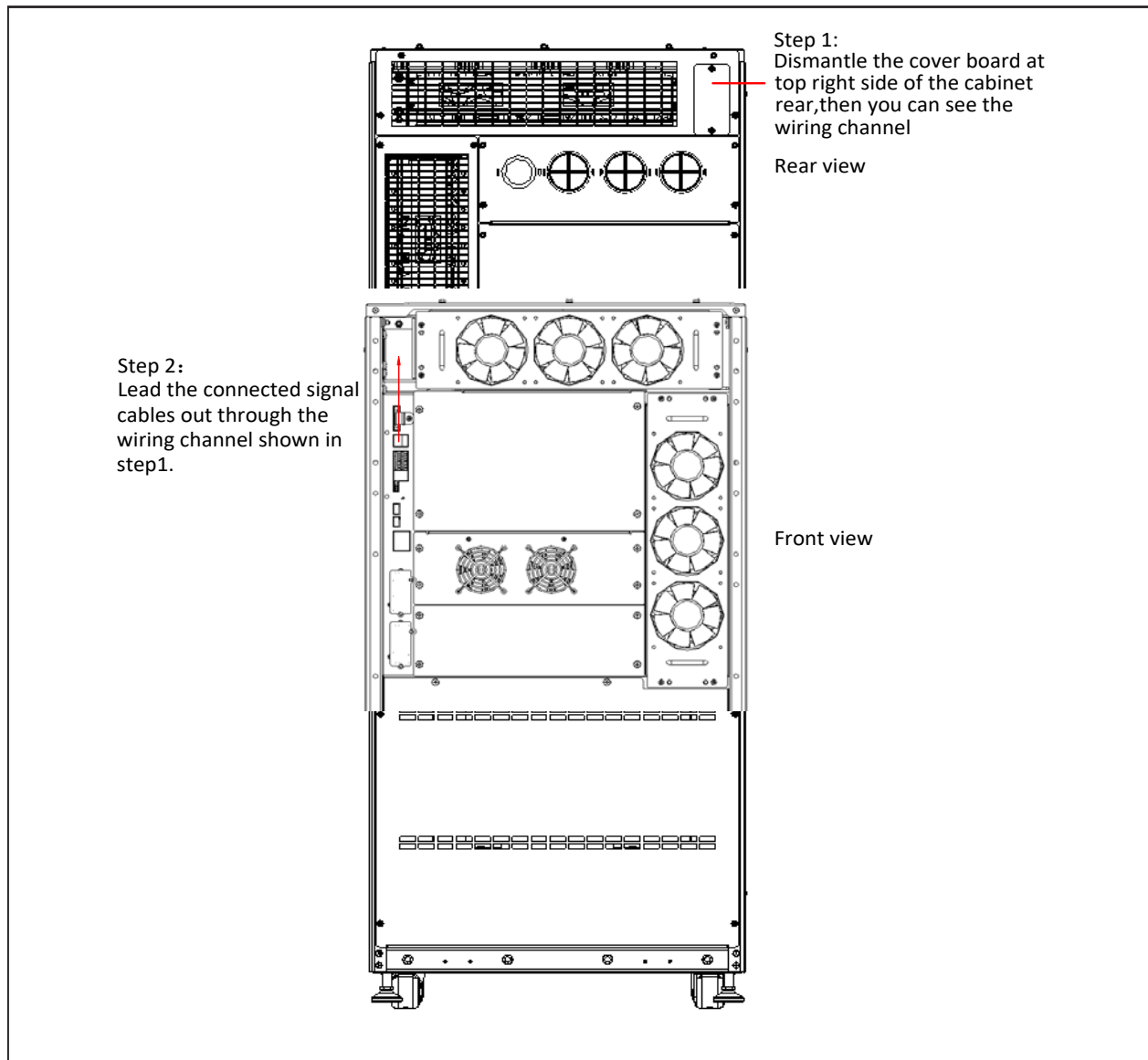

4 Operator Control And Display Panel

This chapter introduces the functions and use of the components on the UPS operation and display panel, and provides LCD display information, including the LCD screen types, detailed menu messages, prompt windows message and UPS alarm list.

4.1 Introduction

The operator and display panel is located on the front panel of the UPS. The operator and display panel allows the user to operate and monitor the UPS, and view the UPS parameters, UPS and battery status information and any alarm messages.

As shown in [Figure 4-1](#), the operator and display panel includes an LCD screen, menu keys, and LED indicators (run indicator and alarm indicator).

Figure 4-1 Operation and display panel

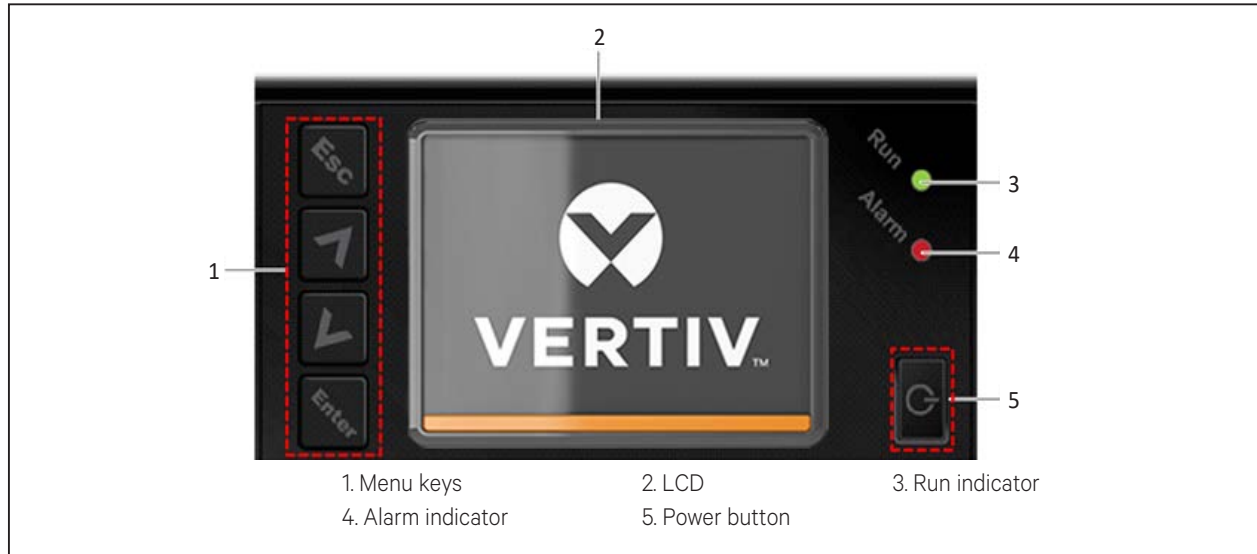

4.1.1. LED Indicators

The LED indicators consist of the run indicator and alarm indicator. [Table 4-1](#) provides a description of these indicators.

Table 4-1 Description of LED indicators

Indicator	Color	State	Meaning
Run indicator	Green	On	UPS output voltage at each phase side is larger than or equal to 60 V
		Off	UPS output voltage at 3-phase side is smaller than 60 V
Alarm indicator	Yellow	On	Alarm active
	Red	On	Fault present
	/	Off	No alarms, no faults

4.1.2. Audible Alarm (Buzzer)

UPS operation is accompanied with the following two different kinds of audible alarms, as described in [Table 4-2](#).

Table 4-2 Description of audible alarm

Sound	Meaning
Continuous beep	This sound is generated in the event of a UPS fault condition, such as a fuse or hardware failure
One beep every 3.3 second	This sound is generated in the event of a general UPS alarm condition

4.1.3. LCD and Functional Keys

The operator and display panel includes five function keys, the respective functions are described in [Table 4-3](#).

Table 4-3 Description of control buttons





Functional key	Silkprint	Description
Confirm		Used to confirm or enter
Up		Used to scroll up, scroll left or increase value, etc.
Down		Used to scroll down, scroll right or reduce value, etc.
Escape		Used to go back, exit, cancel or forbid operation
Power		Used to switch on, switch off or transfer to Bypass mode

Figure 4-2 LCD screen



The LCD includes a user-friendly interface and a 320 × 240 dot matrix image display. Thanks to the user-friendly, menu-oriented LCD it is possible to browse easily through the UPS input, output, load and battery parameters, obtain information about the current UPS status and alarm messages, as well as performing functional setting and control operations.

The LCD also stores historical alarm records that can be retrieved for reference and diagnosis.

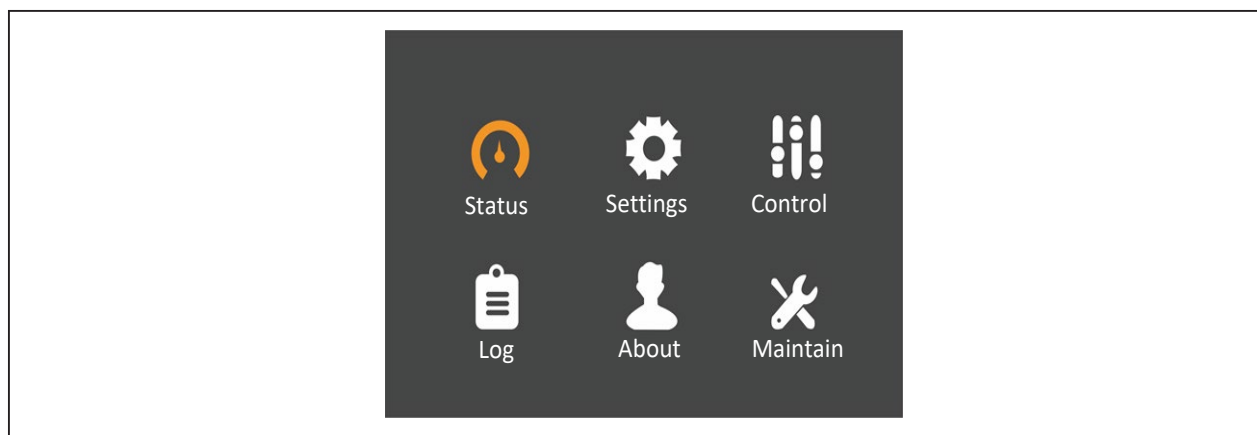
4.1.4. LCD Menu Structure

Figure 4-3 LCD menu structure

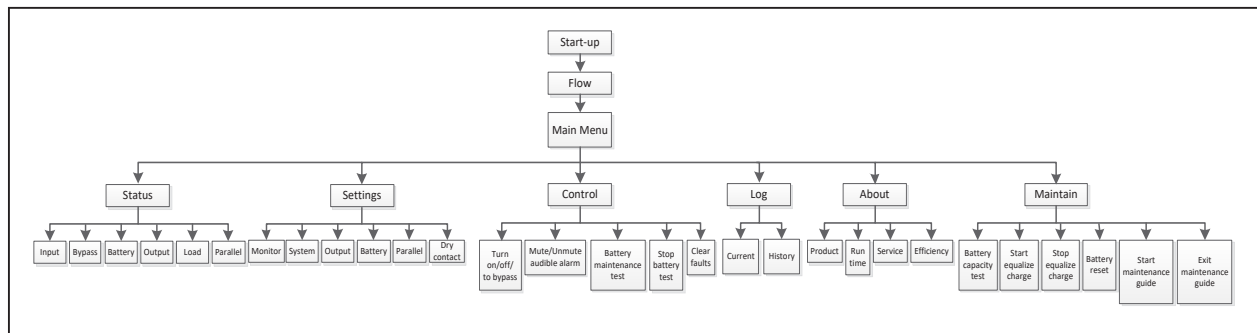

4.2 LCD Screen Types

4.2.1. Start-up Screen

When the UPS is started up it performs a system self-test, during which the Start-up Screen is displayed for approximately 10 seconds, as shown in [Figure 4-4](#).

Figure 4-4 Start-up screen

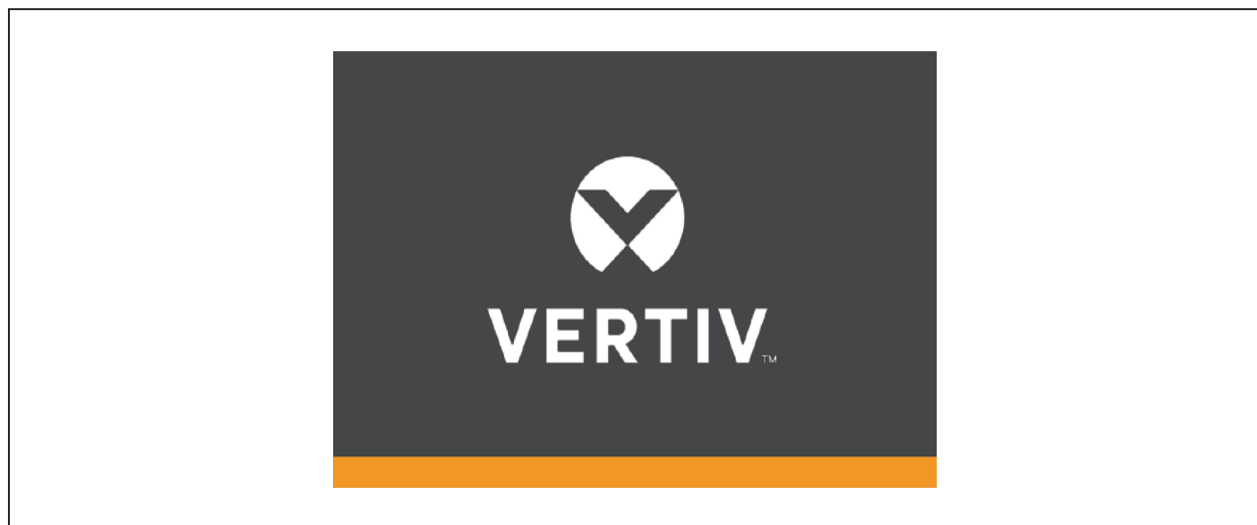

4.2.2.Flow Screen

Once the UPS self-test is complete, the flow screen shown in Figure 4-5 will appear.

The flow screen provides a total status overview of the UPS, including the input, bypass, rectifier, battery, inverter and output, etc. Operating modes are displayed in color, while invalid is displayed in grey.

Figure 4-5 Flow screen

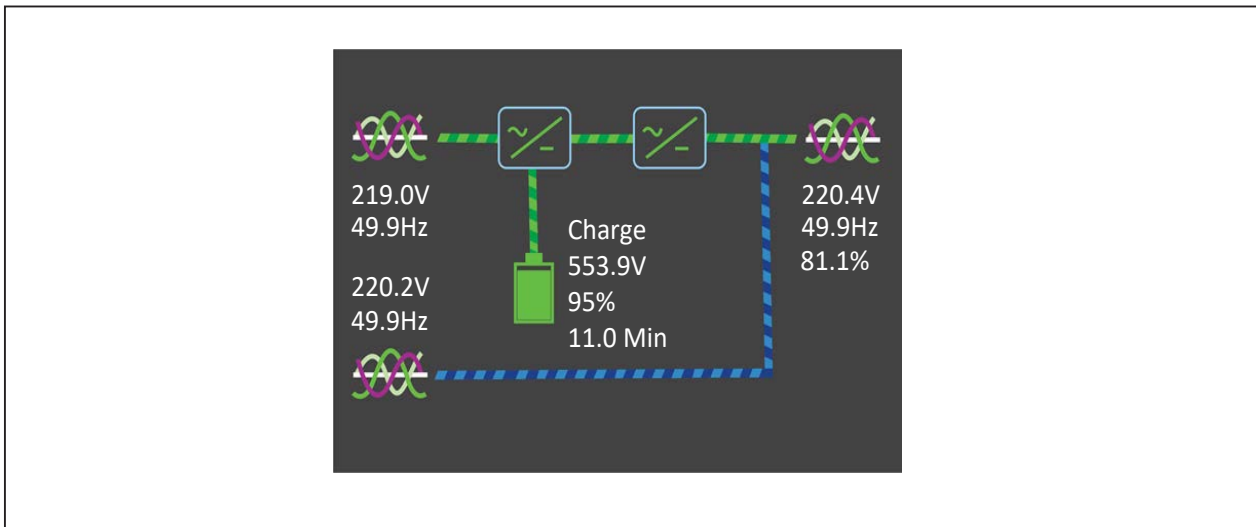

Press the **Enter** key on the flow page to access the main menu screen.

4.2.3.Main Menu Screen

The main menu screen consists of six icons: Status, Settings, Control, Log, About, Maintain. As shown in Figure 4-6.

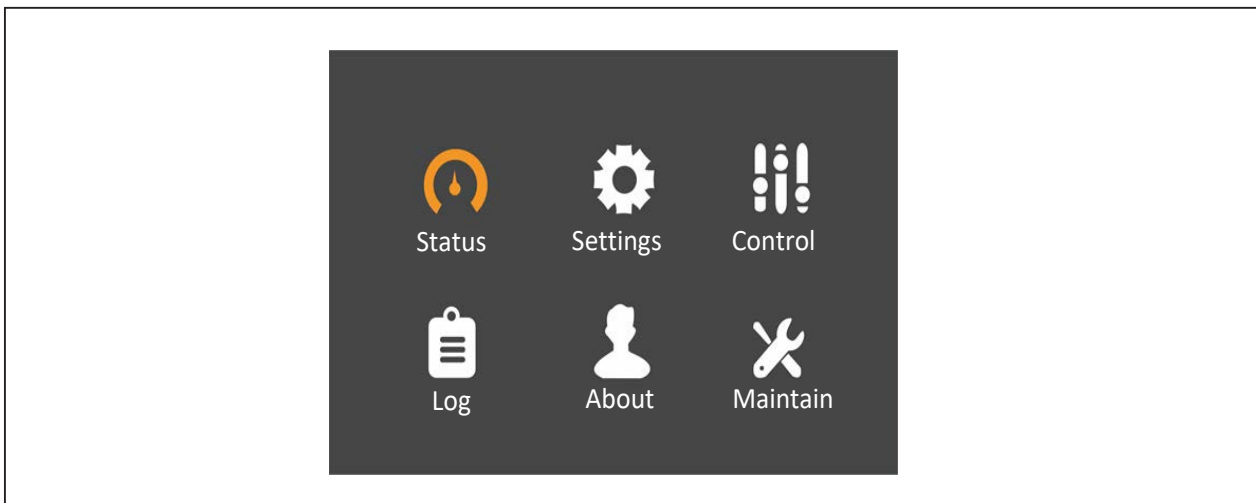

Figure 4-6 Main menu screen



Press the **Esc** key on the main menu screen to return to the flow screen. Press the **Up** or **Down** key to switch the cursor to select the required submenu, then press the **Enter** key to confirm it.

4.2.4.Submenu Screen

The submenu screen contains the UPS parameters and item settings.

After accessing the submenu screen, if there is a tab control, just move the cursor to the tab. At this point, you can press the  or  key to switch the tab. Press the  key to move the cursor to a specific item.

After accessing the submenu screen, if there is no tab control, the cursor will stop on a specific item.

Press the  key to return to the previous screen.

For more details about the submenu screen, see following pages.

Status page

The Status page contains information about the Input, Bypass, Battery, Output and Load.

See below:

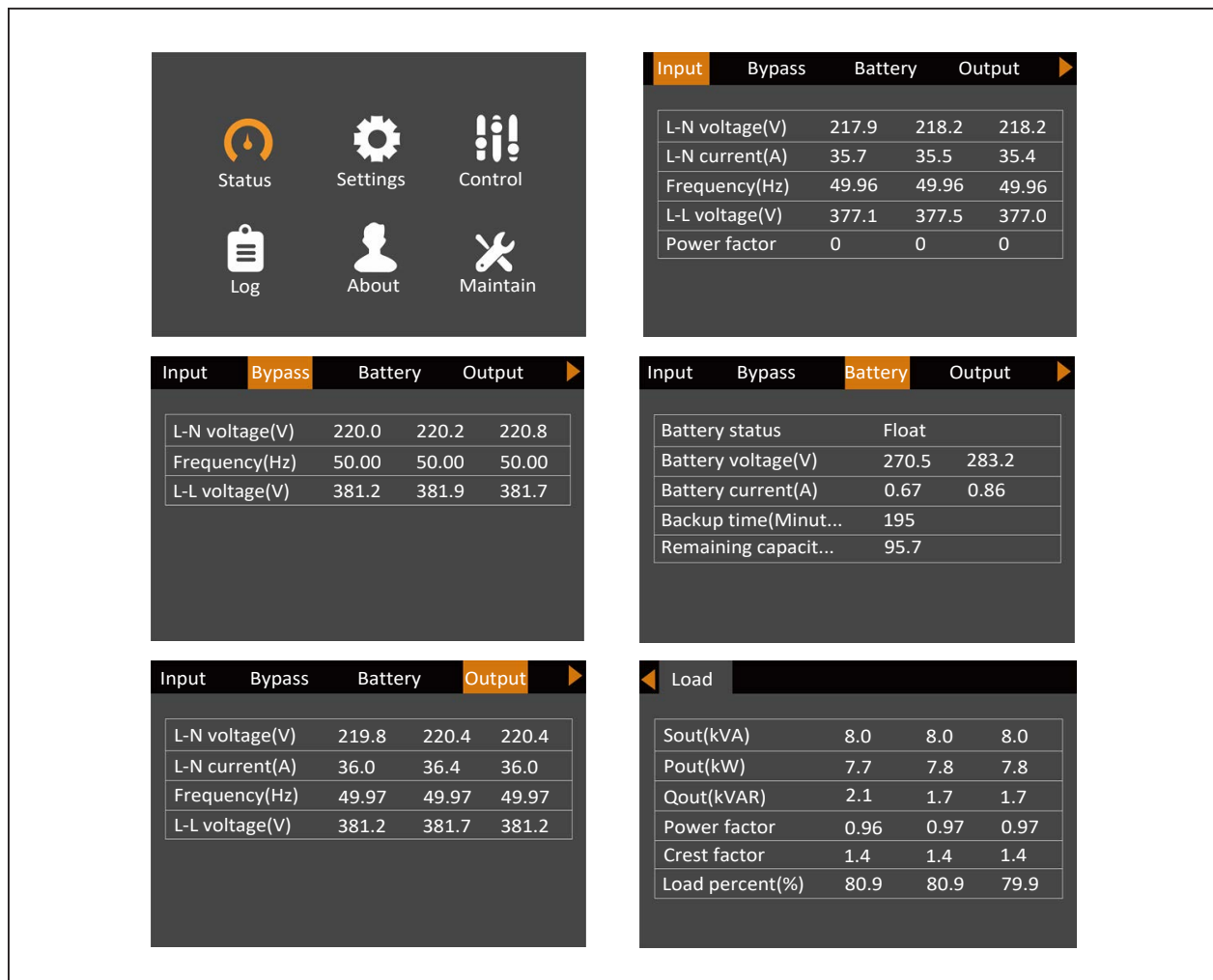

The following tables represent the data shown in the screenshots:

Input Tab Data:

L-N voltage(V)	217.9	218.2	218.2
L-N current(A)	35.7	35.5	35.4
Frequency(Hz)	49.96	49.96	49.96
L-L voltage(V)	377.1	377.5	377.0
Power factor	0	0	0

Bypass Tab Data:

L-N voltage(V)	220.0	220.2	220.8
Frequency(Hz)	50.00	50.00	50.00
L-L voltage(V)	381.2	381.9	381.7

Battery Tab Data:

Battery status	Float	
Battery voltage(V)	270.5	283.2
Battery current(A)	0.67	0.86
Backup time(Minut...)	195	
Remaining capacit...	95.7	

Output Tab Data:

L-N voltage(V)	219.8	220.4	220.4
L-N current(A)	36.0	36.4	36.0
Frequency(Hz)	49.97	49.97	49.97
L-L voltage(V)	381.2	381.7	381.2

Load Tab Data:

Sout(kVA)	8.0	8.0	8.0
Pout(kW)	7.7	7.8	7.8
Qout(kVAR)	2.1	1.7	1.7
Power factor	0.96	0.97	0.97
Crest factor	1.4	1.4	1.4
Load percent(%)	80.9	80.9	79.9

Settings page

The Settings page can be used to access the Monitor and System settings.

See below:

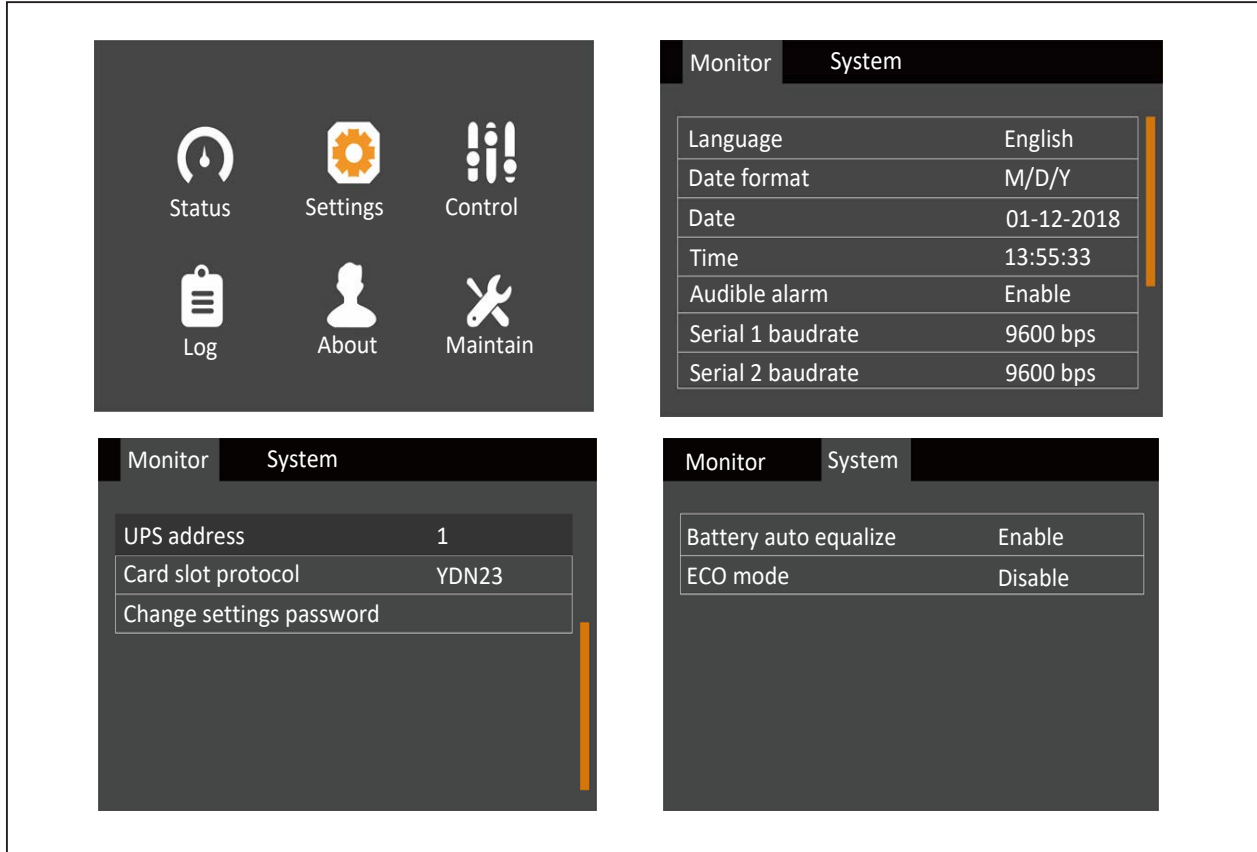

Control page

The Control page may be used to access the Clear faults, Mute/Unmute audible alarm, etc. functions. See below:

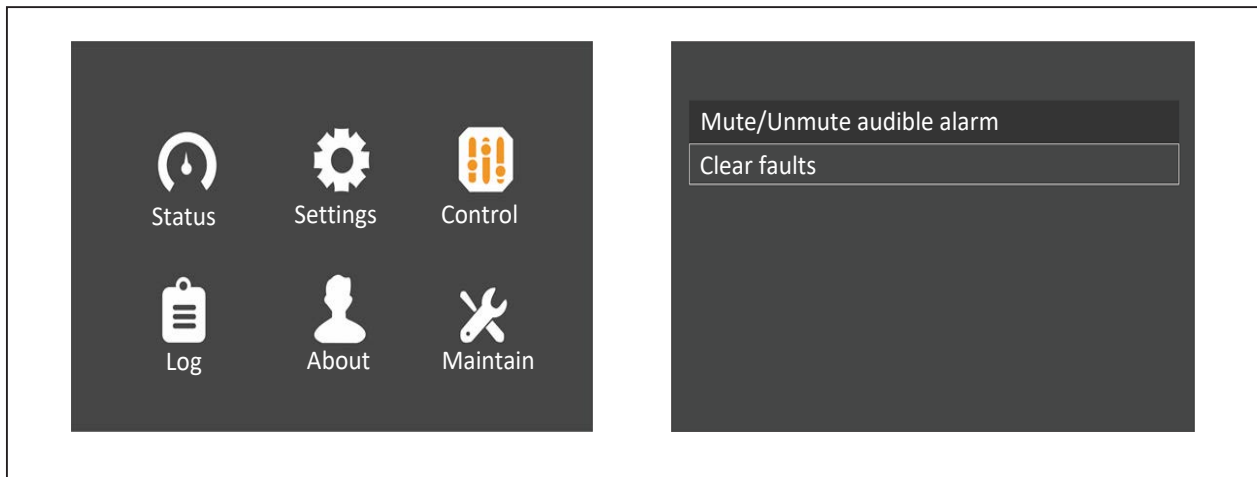

Log page

The Log page can be used to access a list of current and historical UPS events. See below:

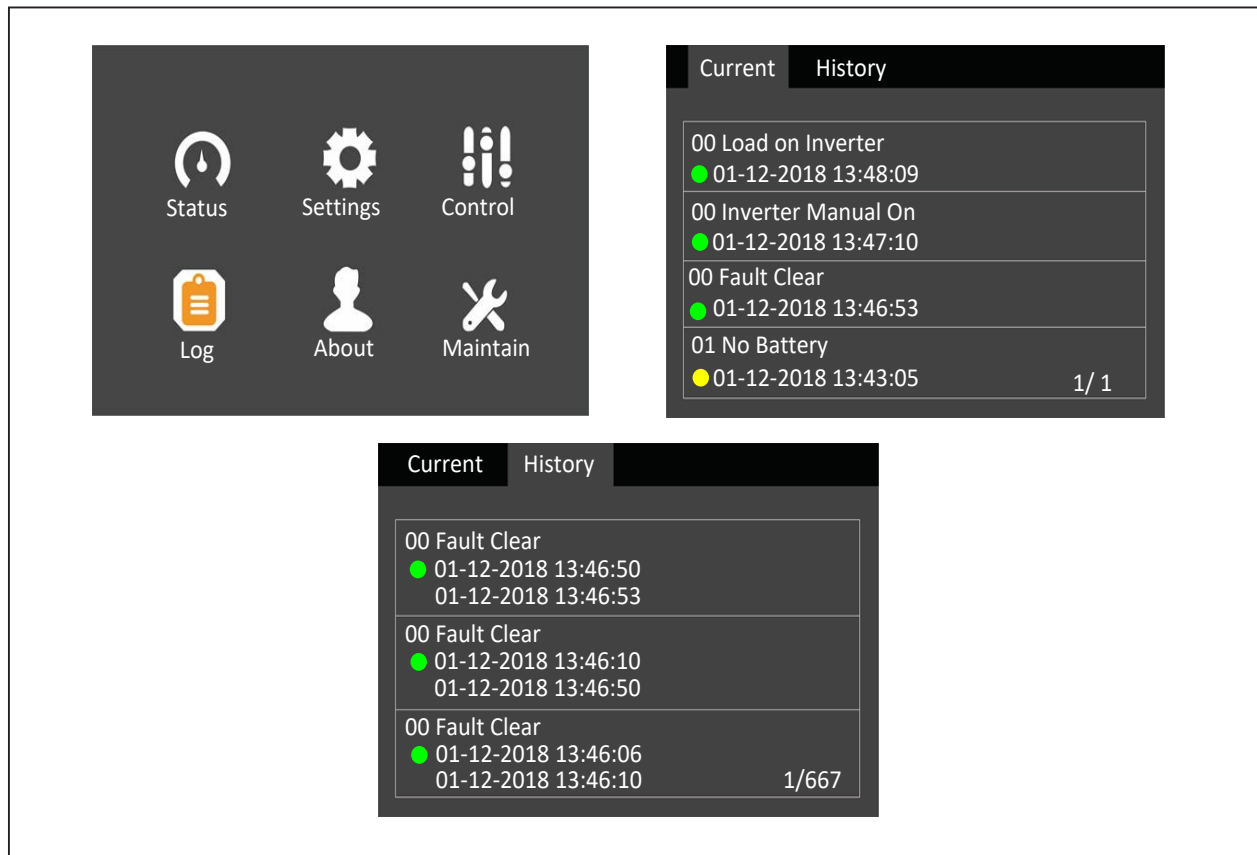

About page

The About page contains information about the Product, Run time, and Efficiency. See below:

The screenshot displays the 'About' page interface. On the left, a dark grey panel contains six navigation icons: Status (gauge), Settings (gear), Control (vertical bars), Log (notepad), About (person), and Maintain (wrench). The main area is divided into two sections. The top section shows a table with three columns: Product, Run time, and Efficiency. The bottom section shows a table with two columns: Product and Efficiency, and a line graph of Efficiency (%) vs Load (%).

Product	Run time	Efficiency
Product type		380V-50Hz-EXS
Serial number		1230000000000...
Monitor APP version		V000B012D000
Monitor Bootloader...		V000B003D000
Monitor Resource ve...		V000B007D000
1# Rectifier DSP ve...		V000B009D000
1# Inverter DSP ver...		V000B010D000

Product	Run time	Efficiency
UPS run time	04Day 17Hour 5...	
Bypass run time	01Day 06Hour 1...	
DCBus capacitance...	01Day 19Hour 1...	
Suspended time rem...	Unknown	
Battery discharge t...	00Day 11Hour 2...	
Battery discharge c...	211	

Product	Run time	Efficiency
UPS run time	04Day 17Hour 5...	04Day 17Hour 5...
Bypass run time	01Day 06Hour 1...	01Day 06Hour 1...
DCBus capacitance...	01Day 19Hour 1...	01Day 19Hour 1...
Suspended time rem...	Unknown	Unknown
Battery discharge t...	00Day 11Hour 2...	00Day 11Hour 2...
Battery discharge c...	211	211

The graph shows Efficiency (%) on the y-axis (89.6, 95.8) and Load (%) on the x-axis (10, 100). The efficiency curve starts at 89.6% at 10% load and rises to 95.8% at 100% load. A label indicates 'Eff.: 89.6%'.

Maintain page

NOTE: The Maintain page is password protected and reserved for use by Vertiv service engineers only.

The screenshot shows a dark grey panel with six navigation icons: Status (gauge), Settings (gear), Control (vertical bars), Log (notepad), About (person), and Maintain (wrench).

4.2.5. Default Screen

During the UPS operation, if there are no alarms for two minutes, the display will revert to the default as shown in [Figure 4-7](#). While the Default screen is displayed, if there are no alarm or fault conditions active, the Flow screen shown in [Figure 4-5](#) will be displayed if the user presses any key.

Figure 4-7 Default screen

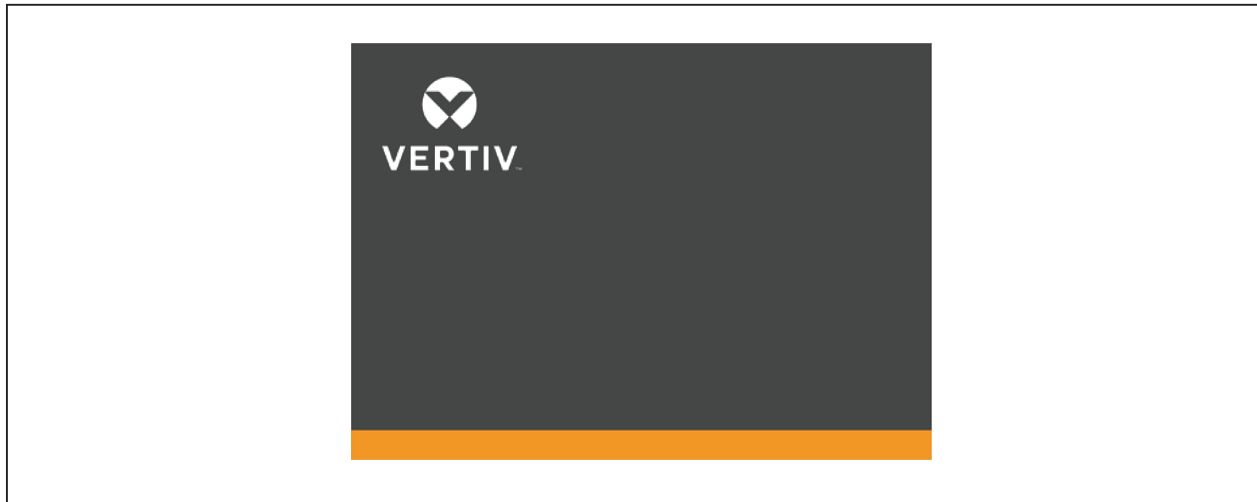

4.3 Prompt Window

A prompt window is displayed while the system is in operation to alert you to certain conditions and/or request you to confirm a command or other operation. Table 4-4 lists the prompts and the associated meanings.

Table 4-4 Prompts and meanings

Prompt	Meaning
Incorrect password, please input again	This prompt will appear when the user enters an incorrect Settings password
Operation failed, condition is not met	This prompt will appear when the user attempts to execute a certain operation, but the necessary condition is not met
Password changed OK	This prompt will appear when the user has changed the Settings password successfully
Fail to change password, please try again	This prompt will appear when the user attempts to change the Settings password but has failed to the same new password twice
Turn on failed, condition is not met	This prompt will appear when the user presses the power button (or executes the 'Turn on/Turn off/to Bypass' command on the 'Control' page)
Battery test abort, condition is not met	The battery self-test condition is not met. The user should verify that the battery is in boost charge mode and the load capacity is larger than 20%
Equalize charge failed, Condition is not met	This prompt appears when you select the Freshening charge command while the battery freshening charge condition (such as no battery, charger failure) is not met
Turn on more UPS to carry current load	The number of inverters already turned on is insufficient to carry the existing load. The user is required to turn on more UPSs
The load is too high to be transferred with interrupt	The total load must be less than the capacity of one UPS to allow a parallel system to perform an interrupted transfer from bypass to inverter

Prompt	Meaning
Turn on local INV? OK or Cancel	This prompt appears when you press the power button, confirm or cancel it
Turn off local INV? OK or Cancel	This prompt appears when you press the power button, confirm or cancel it
Stop battery testing? OK or Cancel	This prompt appears when you select a command to stop battery test , confirm or cancel it
New alarm presents, Show log? OK or Cancel	This prompt appears when there is a new alarm generated, confirm or cancel it
Start equalize charge? OK or Cancel	This prompt appears when you select a command of freshening charge, confirm or cancel it
Stop equalize charge? OK or Cancel	This prompt appears when you select a command to stop freshening charge, confirm or cancel it
Clear faults? OK or Cancel	This prompt appears when you select a command of fault clear, confirm or cancel it
Battery reset? OK or Cancel	This prompt appears when you select a command of battery restore, confirm or cancel it
Start capacity test? OK or Cancel	This prompt appears when you select a command of battery capacity test, confirm or cancel it
Start maintaining test? OK or Cancel	This prompt appears when you select a command of battery maintenance test, confirm or cancel it
Xfer to normal mode, start maintaining test?	This prompt appears when you select a command of battery maintenance test during the system works in ECO mode, confirm or cancel it
Xfer to normal mode, Start capacity test? OK or Cancel	This prompt appears when you select a command of battery capacity test during the system works in ECO mode, confirm or cancel it
Transfer with interrupt, OK or Cancel	Inverter and Bypass supplies are not synchronized and any load transfer between the supplies will cause a brief load interruption
This operation leads to output shutdown, OK or Cancel	No alternative supply is available and any Inverter Off operation will cause the load to be de-energised
This operation leads to inverter overload, OK or Cancel	Turning off this inverter will lead to the overload of remaining inverter(s) in a parallel system
Turn on local INV Turn on PARA INV Turn off UPS	This prompt appears when you press the power button, select one
Turn to bypass Transfer sys. to bypass Turn off UPS	This prompt appears when you press the power button, select one
History log exporting...	The Paramset is exporting the historical log
Please confirm Local INV is off	This prompt will appear when maintenance mode guide starts, please confirm it

Prompt	Meaning
Please confirm PARA INV is off	This prompt will appear when maintenance mode guide starts, please confirm it
Please confirm Int MBB (Maint. Sw.) is closed	
Please confirm Int MBB (Maint. Sw.) and EXT MBB are closed	
Please confirm Int MIB (Output Sw.) is opened	
Please confirm Int MIB (Output Sw.) and EXT MIB are opened	
Please confirm EPO is active	
Please confirm RIB (Input Sw.) is opened	
Please confirm BIB (Bypass Sw.) is opened	
Please confirm BIB (Bypass Sw.) is closed	
Please confirm RIB (Input Sw.) is closed	
Please confirm EPO is cleared	
Please confirm Int MIB (Output Sw.) is closed	
Please confirm Int MIB (Output Sw.) and EXT MIB are closed	
Please confirm Int MBB (Maint. Sw.) is opened	
Please confirm Int MBB (Maint. Sw.) and EXT MBB are opened	
Please confirm PARA INV is on	This prompt appears when you turn off UPS.
Please confirm Local INV is on	
Please open RIB(Inp. Sw.) and BIB(Byp. Sw.) to turn off UPS	
Turn off UPS? OK or Cancel	This prompt appears when you press the power button, confirm or cancel it
This operation leads to bypass over current. OK or Cancel	This prompt appears if the bypass can't supply load during the transfer to bypass operation or turn off UPS operation when system work in bypass mode, confirm or cancel itX
Reset default password? OK or Cancel	This prompt appears when you press UP and Down and Enter button, confirm or cancel it
Shutdown in progress	This prompt appears when you turn off UPS

4.4 UPS Alarm Message List

Table 4-5, Table 4-6 and Table 4-7 list all the UPS alarm messages based on the 'Current' and 'History' menus.

Table 4-5 UPS alarm message list

Alarm	Meaning
Input Phase Reversed	The AC input phase rotation is reversed
Input Voltage Abnormal	The mains voltage is outside specifications and results in rectifier shutdown
Input Frequency Abnormal	The mains frequency is outside specifications and results in rectifier shutdown
Input Undervoltage	At least one phase main input voltage is within 132V ~ 176V, thus the load should be derated
Excess Auto Retransfers	The load remains on bypass power owing to excessive number of transfers that occurred within one hour
Excess ECO Auto Transfers	The load remains on inverter power owing to excessive number of transfers that occurred within one hour
Calibration Shutdown	For tower-type UPS calibration, just select the module to be calibrated via the host software. Shutdown for the modules not to be calibrated, and 'Calibration Shutdown' alarm generated
Load Sharing Abnormal	The UPSs in a parallel system are not sharing the load current correctly
Inverter Asynchronous	The output voltage and bypass voltage are misaligned in phase. This alarm resets automatically once the condition is no longer true
Overvoltage N-GND	Neutral to ground voltage is too high. Check whether the output cable is shorted to the enclosure or not
Bypass Abnormal	The amplitude or frequency of the bypass voltage exceeds the limit
Bypass Phase Reversed	The phase rotation of the bypass voltage is reversed
Bypass Unable to Trace	The bypass voltage and frequency are outside specifications
Bypass Overcurrent	The bypass current is outside the rated current of 1.1 times
Bypass Not Available	Bypass output disabled under generator mode
Bypass Overcurrent Timeout	Bypass overload delay timeout, and the bypass shuts down
Battery Reversed	Reconnect battery and check battery wiring
No Battery	Check the battery fuse, battery and battery connection
Battery Overtemperature	Battery ambient temperature is too high. Check whether the battery ambient temperature is higher than settings value (40 °C by default, settable range: 25-60 °C)
Battery Maintain	Start the battery maintenance discharge test
BCB Open	BCB is opened
Battery terminal short	Check the battery wiring, battery and cabinet port, and battery fuse to verify whether there is short circuit or arc
Battery Voltage High	After connecting the battery, the system measures that the battery voltage exceeds high voltage range. Please check whether the battery terminal voltage exceeds normal range
Output Overload	This alarm will appear when the module load exceeds 105% of the rated value. This alarm resets automatically once the load declines to 95% of rated value
Equalize Charge Timeout	The actual float charging time exceeds the time set by the setting software
Battery Test Fail	The battery self-test condition is not met. The user should verify that the battery is in boost charge mode and the load capacity is larger than 20%
MonCAN Comms. Abnormal	Communication failure among internal monitoring board and inverter, rectifier and bypass
PowerCAN Comms. Abnormal	Internal communication among the inverter, rectifier and bypass gets a failure

Alarm	Meaning
Discrete Bus Comms. Abnormal	Communication failure between discrete bus inside the rack. It is recommended to confirm that the rear communication cables connection inside the rack is reliable
Ambient Overtemperature	Ambient overtemperature detection, can be set via the host software
Fan Abnormal	At least one fan has fault
External MIB Open	The external maintenance isolating switch is opened
Internal MBB Closed	The maintenance switch is closed
External MBB Closed	The external maintenance switch is closed
Maint Isolation Breaker Open	The output switch is opened
Module Output Breaker Open	The external output switch is opened
Load Shed Signal 1 Active	During the battery discharge, if the back-up time or remaining capacity is insufficient, the load shed signal 1 will be activated
Load Shed Signal 2 Active	During the battery discharge, if the back-up time or remaining capacity is insufficient, the load shed signal 2 will be activated
Loss of Redundancy	Loss of redundant capacity
MMS Capacity Exceeded	When the output load of the N+X parallel system is larger than N, there will be an alarm to prompt that I/O switch and cables are bearing rated power exceeding the specified value
LBS Abnormal	LBS is abnormal
Input Transf. Overtemp.	Input transformer overtemperature
Output Short	UPS output has short circuit fault
Load on Maintainance Bypass	UPS in maintainance bypass mode
Battery Voltage Low	Battery voltage too low and out of the normal range based on the battery cells number setting
Byp. SCR Fan Abnormal	The internal fan of bypass module is faulty
Top-outlet Fan Abnor.	The fan of top air outlet is faulty
Bypass Temperature	The bypass radiator has overtemperature

Table 4-6 UPS fault message list

Fault	Meaning
Input Backfeed	Battery voltage fed back to rectifier input. Check that the rectifier SCR is normal
Input Current Abnormal	Battery load sharing imbalance or mains battery frequent transfer more than 5 times within 5min
Input Current Limit	Input current over limit
Input Neutral Missing	AC rectifier input neutral line not detected
Rectifier Fault	Bus voltage abnormal or battery SCR short circuit
Rectifier Soft Start Fail	Owing to low DC bus voltage, the rectifier will report this alarm
Inverter Fault	Inverter output voltage outside specifications. Load transfers to bypass if bypass is available
DC Bus Abnormal Shutdown	DC bus voltage outside specifications. Load transfers to bypass if bypass is available
DC Bus Overvoltage	DC bus overvoltage makes rectifier, inverter and battery converter shut down. Load transfers to bypass if bypass is available
Load Impact Transfer	A transfer to bypass occurred due to a large step load. The UPS can recover automatically. Turn on the load equipment in stages to reduce the load impact on the inverter

Fault	Meaning
Other Module Transfer	All UPSs in the parallel system transfer to bypass at the same time when one of them needs to transfer to bypass. This message appears on the LCD of the UPS with passive transfer to bypass
Bypass Abnormal Shutdown	Both the bypass and inverter voltages are abnormal, and the output is off
Inverter Relay Fail	At least one of the inverter relays is opened or shorted. This fault is locked until mains power-off
Bypass STS Fail	At least one of the STSs at the bypass side is open or shorted. This fault is locked until power-off
Other Bypass STS Fail	The adjacent bypass STS open circuit fault or short-circuit fault
Bypass Backfeed	The bypass back-feed is faulty
Charger Fault	Battery charger has a failure
Low Battery Warning	Before the EOD, battery low pre-warning will occur. After this pre-warning, the battery will have the capacity for 5min discharging with full load. The time is user-settable from 3min to 60min (5min by default)
Battery Ground Fault	Battery has ground fault
BCB Status Abnormal	Logic conflict between BCB drive signal and feedback signal
Discharge Current Limit	Discharge current is over limit, close the discharger
Discharge Fault	Discharger has fault, bus voltage too high or too low during discharger start or soft start, exceeding the setting value
Output Overload Timeout	The UPS overload status continues and the overload times out. When the time has expired, the load automatically transfers to the bypass
Output Fuse Fail	At least one of the inverter output fuses is blown
Output Voltage Abnormal	At least one phase of the output voltages is abnormal
EPO	Dry contact input signal or external EPO command received
Output Disabled	EOD event happened. Check the battery voltage
Control Power Fail	The auxiliary power failure or power-off
Operation Invalid	Maintenance bypass switch is closed when the parallel system is on inverter, or output switch and maintenance bypass switch are closed when the inverter is on
Rectifier DSP SW Error	Rectifier DSP program incorrect, may burn the inverter or bypass DSP
Inverter DSP SW Error	Inverter DSP program incorrect, may burn the rectifier or bypass DSP
Inverter FPGA SW Error	Inverter FPGA program incorrect, may burn the bypass FPGA
Power Hardware Mismatch	The model information set at the host is inconsistent with the actual situation
Parameter Config. Fail	EEPROM operation failed during DSP configuration, or DSP parameter issued by MON failed
Module Overtemperature	The power tubes of rectifier and inverter inside the module have overtemperature
Charger Overtemperature	The power tube of charger inside the module has overtemperature
Pwr. Mod. Unauthorized	The module does not work due to unauthorized power module. Please contact the service center of the manufacturer to get corresponding authority
HMI Unauthorized	The UPS does not work due to unauthorized HMI. Please contact the service center of the manufacturer to get corresponding authority

Table 4-7 UPS prompt message list

Fault	Meaning
Rectifier in Setting	The rectifier starts up and is in synchronization
Inverter in Setting	The inverter starts up and is in synchronization with the monitoring
Battery Reset	The battery state restores to a new one
Battery End of Discharge	Inverter turned off due to battery EOD
BCB Closed	BCB state (closed)
Charger Shutdown	Dry contact signal. When the dry contact gives a command of charger shutdown, then the charger will shut down
Fault Clear	Select the command of 'Clear faults' via the Control page
Silence Active	Select the command of 'Mute/Unmute audible alarm' via the Control page
Silence Inactive	Under conditioner of buzzer silence, select the command of 'Mute/Unmute audible alarm' via the Control page
Inverter Manual On	Power button on the operator control and display panel pressed to manually turn on the inverter
Turn On Fail	The inverter failed to turn on when the Inverter Manual On is pressed. This may be the result of an invalid operation (maintenance bypass switch closed) or DC bus or rectifier not ready
Inverter Manual Off	Power button on the operator control and display panel pressed to manually turn off the inverter
Autostart	After UPS shutdown at EOD, the inverter automatically starts upon mains restoration
Load on Bypass	UPS is in bypass mode
Load on Inverter	UPS is in normal mode
Load on Battery	UPS is in battery mode
Load Off	UPS shut down, both bypass and inverter have no output
Automatic Battery Test	The battery is under automatic periodic battery maintenance discharge test (20% capacity discharge)
Calibrated Battery Test	The user initiates a battery capacity test (100% capacity discharge)
Manual Battery Test	The user initiates a maintenance test (20% capacity discharge)
Rectifier DSP Update	Rectifier DSP software being updated
Inverter DSP Update	Rectifier FPGA software being updated
Inverter FPGA Update	Inverter DSP software being updated
Monitor Update	Inverter FPGA software being updated
Remote Turn On	Turn on the inverter through the service command
Remote Turn On Fail	Caused by invalid operation (maintenance bypass switch closed), DC bus or rectifier not ready
Remote Turn Off	Turn off the inverter through the service command
Flash Operate Fail	Historical record not saved
Battery Equalize Charge	The battery is forced to be in boost charge state
On Generator	Dry contact signal. The system is in generator mode
RIB Open	The input switch is opened
Internal MBB Open	The maintenance switch is opened
External MBB Open	The external maintenance switch is opened

Fault	Meaning
Bypass Input Breaker Open	The bypass switch is opened
System Interrupt Transfer	Execute the interval transfer under conditions of bypass unable to trace and inverter phase not locked
LBS Active	LBS is enabled
Module in Sleeping	The module is in sleep mode and the module does not work. Only the UPS configured with intelligent parallel mode or intelligent ECO demo mode can present this state
Module Comms. Normal	Communication between the module and monitoring is normal
ECO Mode Enabled	ECO mode enabled
ECO Mode Active	ECO mode activated
Freq. Converter Mode Enabled	Frequency converter mode enabled
Freq. Converter Mode Active	Frequency converter mode activated
IP Mode Enabled	Intelligent parallel mode enabled, that is sleep mode
IP Mode Active	Intelligent parallel mode activated, that is sleep mode
IP Mode Demo Enabled	Intelligent parallel demo mode enabled, that is sleep demo mode
IP Mode Demo Active	Intelligent parallel demo mode activated, that is sleep demo mode
Regen. Mode Enabled	Self-aging mode enabled
Regen. Mode Active	Self-aging mode activated
Testing Mode Enabled	Testing mode enabled
Testing Mode Active	Testing mode activated
Pwr. Conditioner Mode Enabled	Power conditioner mode enabled
Pwr. Conditioner Mode Active	Power conditioner mode activated
MMS Inv. Manual Off	Power button is pressed on one UPS, and select the parallel system for unified shutdown
MMS Inv. Manual On	Power button is pressed on one UPS, and select the parallel system for unified start-up
Suspend ECO Mode	This alarm appears when input dry contact "Suspend ECO Mode" active. The UPS will stay in inverter mode and ECO mode will be inhibited
Inhibit Trans. to Inverter	This alarm appears when input dry contact "Inhibit Trans. to Inverter" active. The UPS will stay in bypass mode and inverter mode will be inhibited
Battery Test Stopped	Battery test has been stopped manually

NOTE: 1. For UPS installed with the optional battery monitor, refer to the user manual of the battery monitor for the alarm messages related to battery cell and charge current.
2. If the alarm is generated as the result of a software value set-up by Vertiv engineer, and you wish to modify the setting, please get in touch with your local Vertiv customer service center.

5 UPS Operating Instructions

This chapter introduces the operating precautions and routine operating methods of UPS in detail.

5.1 Brief Introduction

5.1.1. Precautions



IMPORTANT! The user can conduct relative operation only after the Vertiv engineer carries out the first power on and test.



WARNING! hazardous mains and/or battery voltage

1. No operator-serviceable parts are located behind covers that require a tool for their removal. Only qualified service personnel are authorized to remove such covers.

2. The AC/DC input and output terminals of UPS have dangerous voltage at any time. If the cabinet is equipped with an EMC filter, the filter may have dangerous voltage.

1. For the operation keys and LCD related to all the operating steps, refer to Chapter 4 Operator Control And Display Panel.
2. During operation, the buzzer alarm may be activated, if so, you can select the command of 'Mute/ Unmute audible alarm' via the Control page to silence the audible alarm.
3. When UPS uses traditional lead-acid battery, the system provides boost charge optional function. If the lead-acid battery is used, when the mains returns after an extended mains failure, the charging voltage of the battery will be higher than the normal charging voltage, this is normal, and the charging voltage of the battery will return to normal value after a few hours' charging.

5.1.2. Power Switch

Opening the front door of the UPS cabinet reveals the power switches, as shown in Figure 5-1, including:

Q1: Rectifier input switch, which connects the UPS to the main circuit power.

Q2: Bypass input switch, which connects the UPS to the bypass.

Q3: Maintenance bypass switch (lockable), which supplies power to the load when UPS is being maintained.

NOTE: If the UPS system is composed of more than two paralleled UPS modules, do not use the internal maintenance bypass switch.

Q5: Output switch, which connects the UPS output to the load.

Figure 5-1 UPS power switch

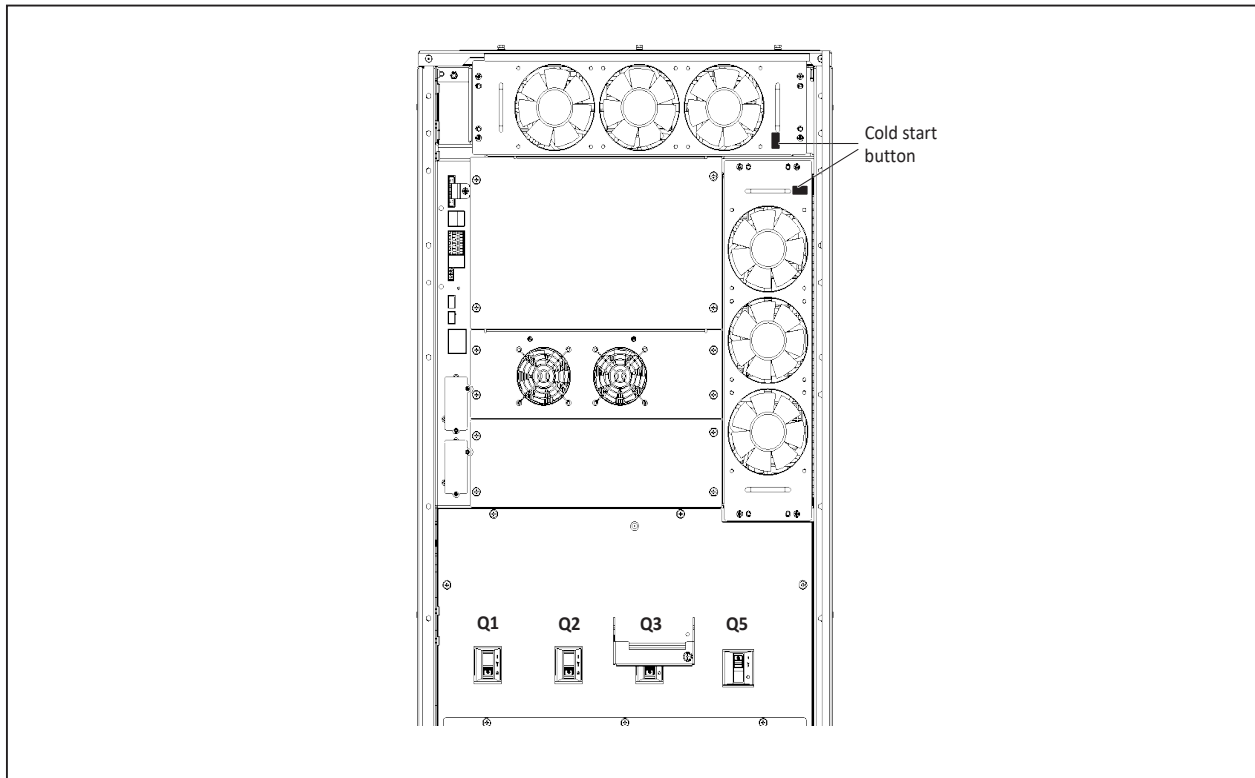

5.1.3. Check before Start-up

1. Check and confirm that the UPS power distribution mode is correct, that the power cables and signal cables are connected correctly, and there are no short circuits.
2. Check that the batteries have been installed properly, the cables have been connected correctly, and that the positive and negative battery poles are correct.
3. Measure the mains voltage and frequency, and verify that they are correct.
4. The UPS output terminals are energized when the UPS is switched on. If the load has been already connected to the output terminals, make sure that it is safe to apply power to it.



Important! The user may only switch the UPS on once the UPS has been installed completely and the authorized service engineer has completed the commissioning tests and shut down the external power input switches.

5.2 UPS Start-up Procedures

The UPS must be completely installed and tested by authorized engineer, and external power supply switch is closed, then you can start the UPS.

5.2.1. Start-up Procedures in Normal Mode



WARNING! 1. To avoid misreporting as faults, all operations relating to disconnection or connection of the maintenance bypass switch shall be finished within three seconds.
2. After the output is closed, if any loads are connected to the UPS output terminals, check with the user that it is safe to apply power.

Use the following procedures to switch the UPS on when it is in the fully switched off state.

1. Open the front door of the UPS, ensure that the internal maintenance bypass switch Q3 is off, and that the input cables and PE terminals are connected securely.
2. Close the output switch Q5, bypass input switch Q2 and main input switch Q1 in turn.
3. At the moment, the system is powered on, and the UPS internal cooling fan starts. The rectifier executes self-check and starts to run. The rectifier runs in normal state for about 30 seconds, after which the rectifier start-up phase is complete. See [Figure 5-2](#) for power flow page.

Figure 5-2 Flow page

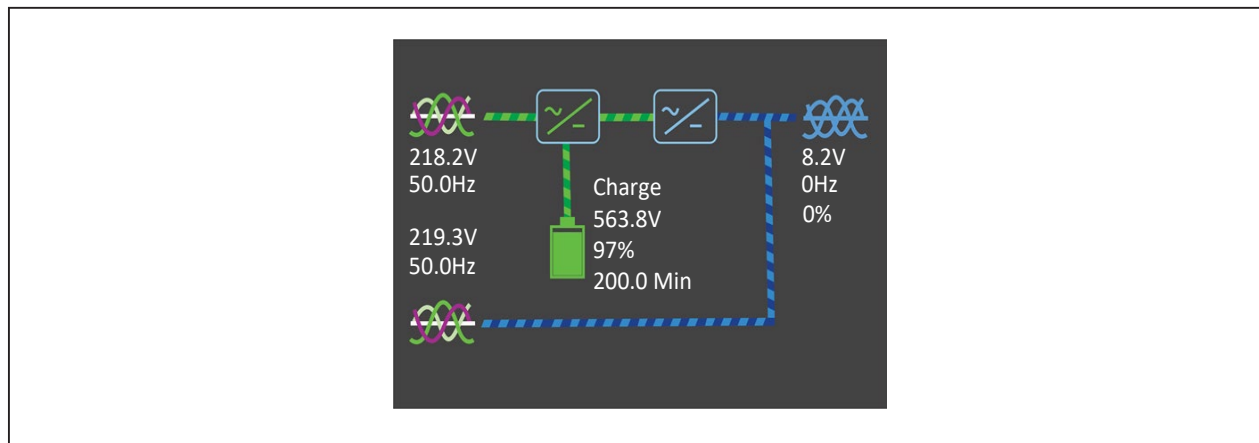

4. Finish setting up the single UPS parameters and check them.

Access the main menu screen, press the or key to select 'Status', and press the key to access the interface shown in [Figure 5-3](#).

Figure 5-3 Main menu screen

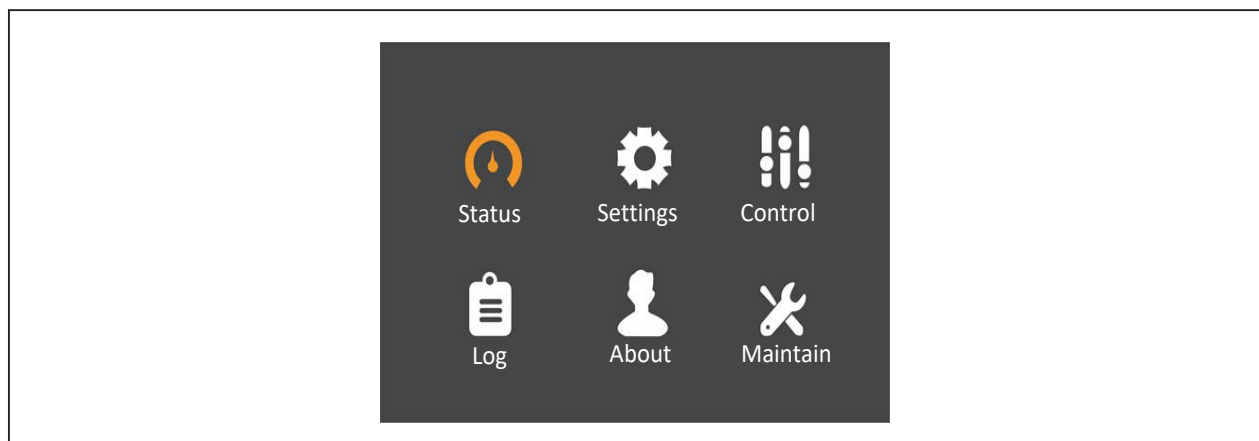

Check that the parameters containing input, bypass, battery voltage, frequency and phase are correct, and then back to the Flow page.

5. Access the flow page, press and hold the power button, and the LCD prompt a dialogue box, as shown in [Figure 5-4](#). After selecting 'YES', the inverter executes self-check and start-up. After the inverter runs normally, the UPS will transfer to normal mode, and the run indicator will be solid on. See [Figure 5-5](#) for the power flow page.

Figure 5-4 Switching the UPS on

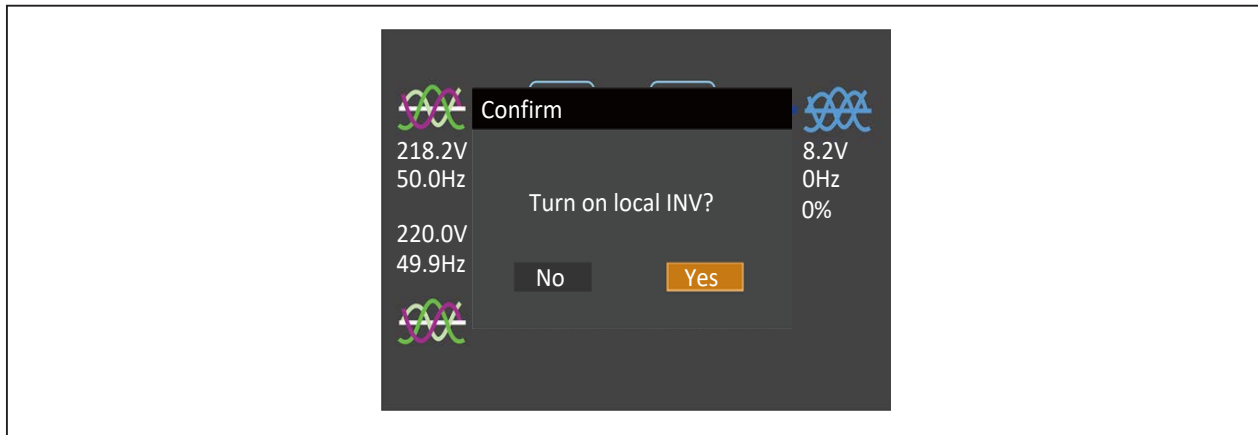
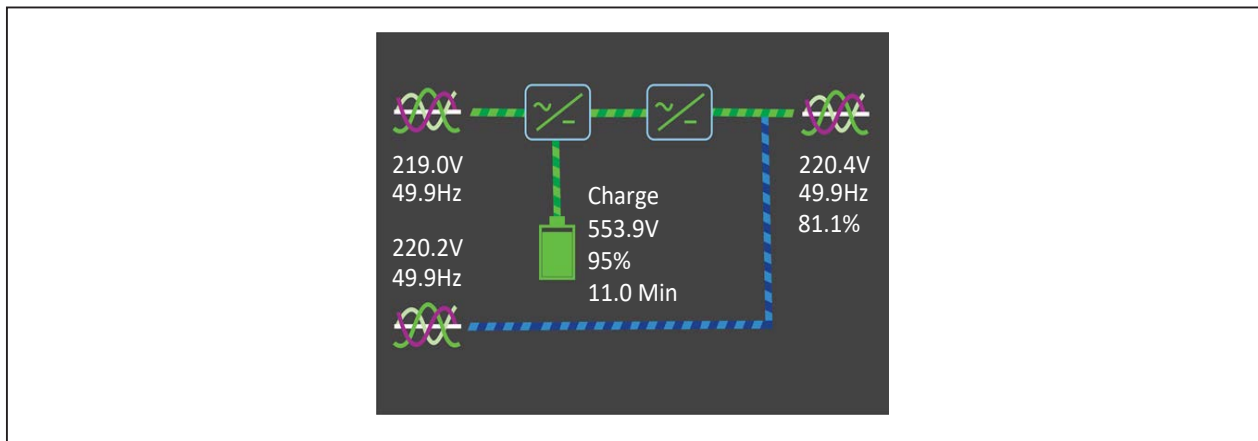

Figure 5-5 Flow page appears after inverter on



6. Access the main menu screen again, select 'Status' to check that the parameters like inverter output voltage and frequency are normal. If so, the start-up is complete.
7. If the battery is not connected, the alarm indicator will be colored yellow. If the battery is connected, the alarm indicator will be off.

5.2.2. Start-up Procedures in Battery Mode (Battery Cold Start)

1. Check and confirm the batteries are well connected.
2. Open the front door of the UPS, press and hold any battery cold start button for 2s (see [Figure 5-1](#) for its position). At the moment, the system is powered on, and the startup screen pops up. Refer to [4.2.1. Start-up Screen](#).
25 seconds later, the discharger executes self-test and start-up, and the alarm indicator (red) is solid on. 30 seconds later the discharger start-up phase will complete.
3. Access the flow page, press the power button, and the LCD prompt a dialogue box, as shown in [Figure 5-4](#). After selecting 'YES', the inverter executes self-check and start-up. After the inverter runs normally, the UPS will transfer to normal mode, and the run indicator (green) will be solid on.
4. Access the main menu screen again, select 'Status' to check that the parameters like inverter output voltage and frequency are normal. If so, the start-up is complete.

5.3 Procedures for Transferring between Operating Modes

NOTE: The Inverter operating modes include Normal mode and Battery mode.

5.3.1. Transfer from Normal Mode to Battery Mode

Open the external power switch or disconnect switch Q1 to isolate the mains power and initiate the UPS on battery mode. If you wish to transfer the UPS from Battery mode to Normal mode, wait few seconds for the mains input to recover by closing the external power switch or switch Q1. After about ten seconds, the rectifier will restart automatically, and the inverter will restore the power.

5.3.2. Transfer from Normal Mode to Bypass Mode

NOTE: In bypass mode, the load is directly fed by the mains power instead of the pure AC power from the inverter.

In Inverter mode, press the power button. If the bypass is normal, the interface shown in [Figure 5-6](#) will appear. Select 'YES' to transfer the UPS to Bypass mode, see [Figure 5-7](#) for the power flow page.

Figure 5-6 Bypass normal interface

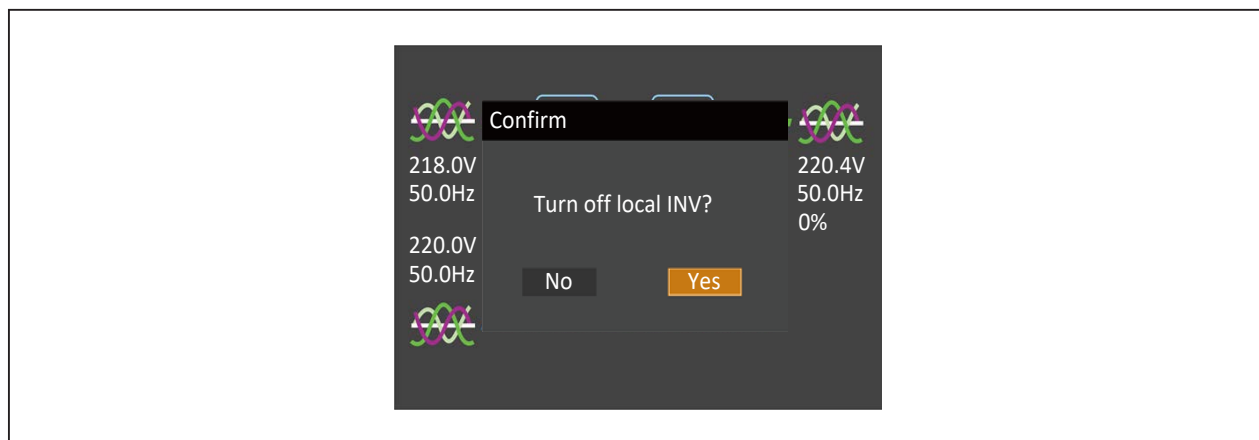
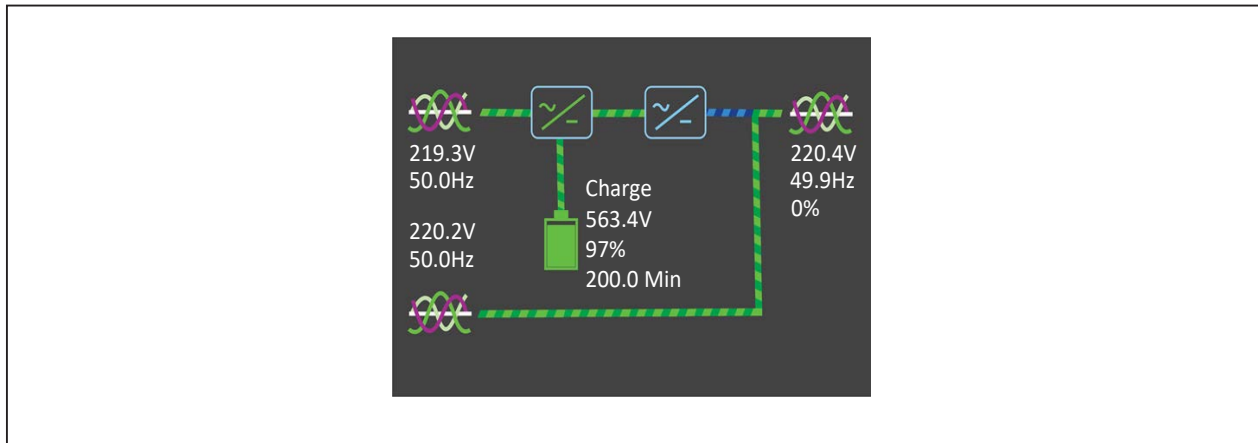
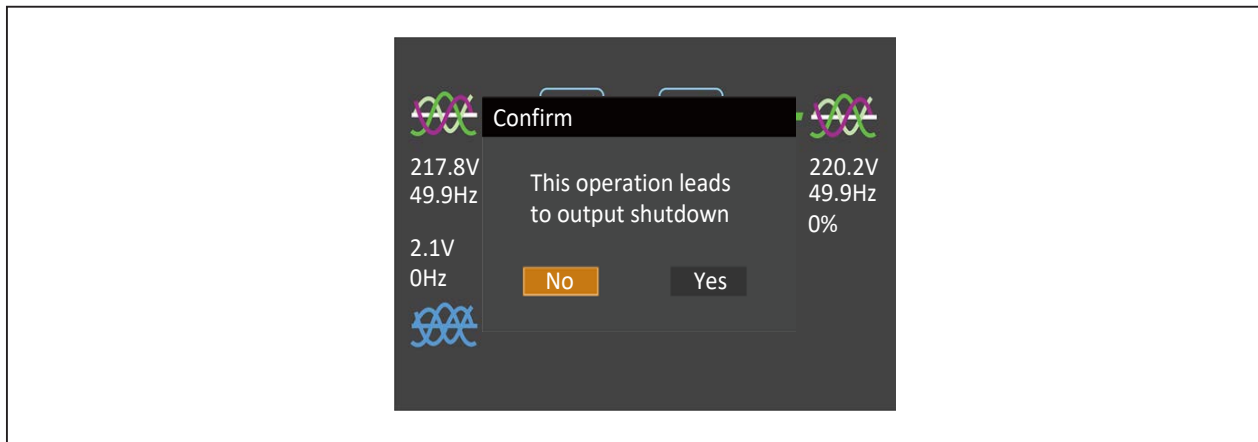

Figure 5-7 Flow page on bypass



In Inverter mode, press the power button. If the bypass is abnormal, then the interface shown in [Figure 5-8](#) will appear, select 'NO' to shut down the UPS output.

Figure 5-8 Bypass abnormal interface



5.3.3. Transfer from Bypass Mode to Normal Mode

In Bypass mode, press the power button, and the LCD prompt a dialogue box, as shown in [Figure 5-9](#). After selecting 'YES', the inverter executes self-check and start-up. After the inverter runs normally, the UPS will transfer to normal mode, and the run indicator will be solid on.

Figure 5-9 Switching the UPS on

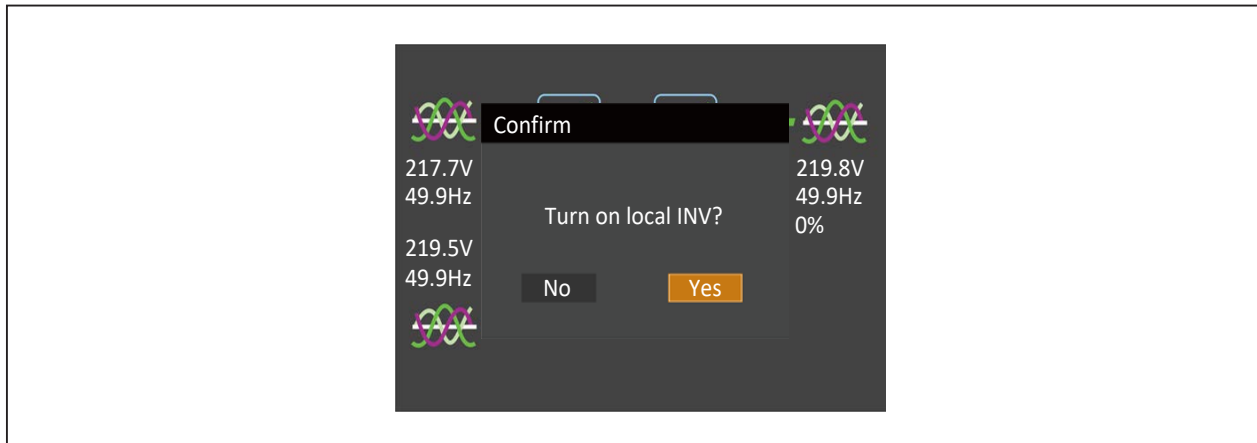

In Bypass mode, press the power button, and the LCD prompts a dialogue box shown in Figure 5-10 if the alarm 'Bypass unable to trace' appears. After selecting 'YES', the system will automatically transfer to Normal mode. Select 'NOT', the system still works in Bypass mode.

Figure 5-10 Transfer with interruption

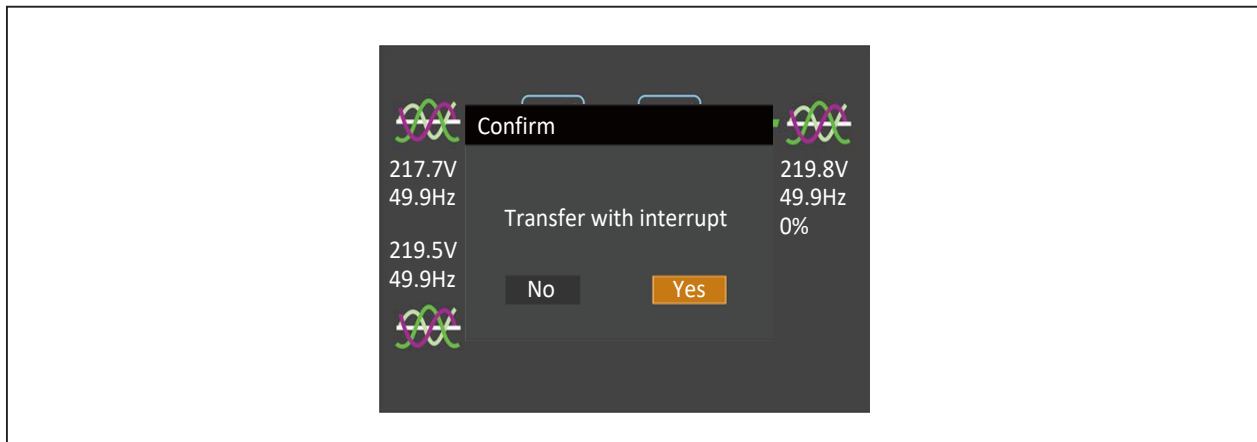

5.3.4. Transfer from Normal Mode to Maintenance Bypass Mode

When the UPS is running in Normal mode, you can use this procedure to transfer the load from inverter output to maintenance bypass.



CAUTION: Power supply interruption danger of the load
Before performing this procedure, you should check the LCD information first, and make sure the bypass is normal and synchronizes with the inverter. Failure to do so may result in a brief interruption in the power supply to the load.

1. In Inverter mode, press the power button to transfer the load to maintenance bypass mode, and the inverter will be shut down.
2. If the UPS runs in single module mode, open the cabinet front door and remove fixing screws of the maintenance bypass switch baffle, rotate the baffle leftwards until it is locked in position, then fasten the fixing screws. At the moment, the LCD displays 'Maint. Switch Closed'.

3. Close the maintenance bypass switch Q3. At the moment, the maintenance bypass parallels with the UPS bypass.
4. Unplugging the EPO terminal disconnects the output switch Q5, main input switch Q1, bypass input switch Q2. At the moment, all the internal power supply is off and the LCD does not display any more, and the maintenance bypass power the load normally.



CAUTION: When the UPS is in maintenance bypass mode, the load is not protected against abnormalities in the mains power supply.

NOTE: In maintenance mode, the load is directly fed by the mains power instead of the pure AC power from the inverter.



WARNING! 1. If the maintenance is required, wait 10 minutes for the internal DC bus capacitance discharging.
2. The parts of UPS circuits also have hazardous voltage, though the rectifier input switch, bypass input switch and battery switch are disconnected. Therefore, the UPS maintenance is applicable to qualified personnel only.

5.3.5. Transfer from Maintenance Bypass Mode to Normal Mode

Following UPS maintenance operations, the following procedures may be used to transfer the load from the maintenance bypass to the inverter.

1. Push the baffle of maintenance bypass switch Q3 leftwards to the end position, and keep it stay this position.
2. Close the output switch Q5, main input switch Q1 and bypass input switch Q2 in turn. Confirm that the LCD is on and the UPS runs in Bypass mode.
3. Following the LCD start-up, ensure that the system is operating in Bypass mode. Set maintenance bypass switch Q3 to off. Return the Q3 baffle to its original position, then fasten the fixing screws.
4. Press the power button on the operator and display panel of the UPS so that the UPS transfers to Inverter mode.



WARNING! It is important to close the bypass switch before opening the maintenance bypass switch; otherwise the power supply to the load will be interrupted.

5.4 Battery Test Procedures

The battery test function is disabled by default. If you need this function, please contact the customer service engineer of Vertiv.

Battery test type and preconditions

1. There are two battery tests to select from:
 - Battery maintenance test: verifies the battery integrity and leads to the battery being partly discharged (20%).
 - Battery capacity test: verifies precisely the battery capacity and leads to the battery being fully discharged (until Battery low pre-warning alarm)







2. The tests can be carried out from the operator control and display panel of the UPS by the operator when the following conditions are satisfied:
 - The load must be between 20% and 80% of rated UPS capacity and must be stable (for battery maintenance test)
 - The load must be between 20% and 80% of rated UPS capacity and must be stable (for battery capacity test)
 - The battery must have been float charging for 5 hours or more before battery capacity test

The battery test procedures are password controlled and menu driven. The test is immediately terminated in the event of a battery or a mains failure and the total load power is supported from the remaining source without interruptions.

Test procedure

1. Access the Maintain page via main menu screen (see Figure 4-10) on the operator control and display panel of the UPS.

Use  or  key to navigate to the **Command** menu.

2. Use  or  key to select the desired test (the Battery maintenance test or Battery capacity test option), and press  key to confirm it. When prompted, enter each password digit with a Use  or  key to to access next field. Press the  key when all digits have been entered.

3. Wait until the test completes.

This test updates the battery information, including the battery back-up time (battery discharge duration during AC input failure) and the battery aging coefficient (battery capacity percentage when compared to a new battery).

4. Stop the test.







If required, the test may be stopped before completion by selecting Stop testing on the Command menu.

NOTE: The battery capacity self-test needs to guarantee the discharge time not less than 6min, otherwise the battery self-learning time may be insufficient and the battery curve will not be updated.

5.5 System Test Procedure

The UPS test procedure checks the control functions of the UPS, LED indicators and audible alarm. This self-test is password controlled and menu driven. It can be carried out from the operator control and display panel by the operator.

Test procedure:

1. Access the Maintain page via main menu screen (see Figure 4-10) on the operator control and display panel of the UPS.
2. Use  or  key to select the **System** test, and press  key to confirm it. When prompted, enter each password digit with a Use  or  key to to access next field. Press the  key when all digits have been entered.

3. Wait until the test completes.

After five seconds, a pop window will appear to show the result of this diagnosis: rectifier, inverter, monitor OK or fault.

5.6 UPS Shutdown Procedures

5.6.1. Procedures for Completely Powering down UPS

In order to shut the UPS down completely and disconnect the power supply to the load, proceed as follows: All power switches, isolating switches and breakers are switched to off, and the UPS no longer supplies power to the load.



CAUTION: The following procedures will interrupt the power supply to the load, switching it off.

1. Unplug the EPO terminal to deactivate the rectifier, inverter, bypass and battery.
2. Set the main input switch Q1, bypass input switch Q2, output switch Q5 to off. At this point, all the internal power supplies are deactivated and the LCD screen is switched off.



**WARNING! 1. Post a label on the AC input distribution line (generally at a distance from the UPS) to alert personnel that UPS maintenance is in progress.
2. Wait 10 minutes for the internal DC bus capacitors to discharge. Then the UPS is completely shut down.**



**WARNING! Hazardous battery voltage
Hazardous voltages are still present on the battery terminals, even after the UPS has been shut down completely.**

5.6.2. Procedures for Completely Powering down UPS while Maintaining Power to Load

The following procedures are applicable to completely powering down the UPS and still keeping the power supply to the load. Refer to the procedures in Section 5.3.4.

5.7 EPO

The REPO is designed to switch off the UPS in emergency conditions (such as fire, flood). To carry out EPO, you just need to unplug the EPO terminal, then the system will turn off the rectifier, inverter and stop powering the load immediately (including the inverter and bypass), and the battery stops charging or discharging.

After REPO, if the mains input is present, the UPS control circuit will remain active; however, the output is interrupted.

To completely remove all mains power from the UPS, open the main input switch Q1, bypass input switch Q2, output switch Q5 in turn, and then open the battery terminals.

5.8 UPS Reset Procedures after EPO

After shutting down the UPS through EPO or reasons of inverter overtemperature, overload, battery overvoltage and DC bus voltage, clear the fault according to the alarm message displaying on LCD screen. Then carry out the following reset procedures to make UPS resume normal operation.

After confirming the fault has been cleared, just plug the EPO terminal, and the user can carry out the following procedures:

1. Access the main menu screen (see [Figure 4-6](#)). Use  or  key to select the 'Control' page, see [Figure 5-11](#). Click the 'Clear faults' button, and press  key to make the system exit the REPO/ abnormal OFF state, and the alarm indicator in red color will be off.

Figure 5-11 Control page

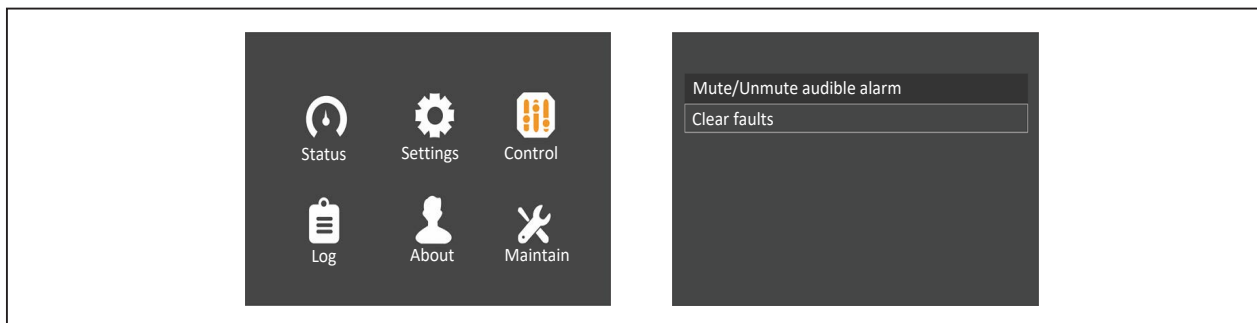

2. Press the power button to start the inverter. After the inverter runs normally, the UPS will transfer from Bypass mode to Normal mode, and the run indicator (green) will be solid on. Now the UPS restore is complete.

5.9 Automatic Restart

In the case of a mains failure, the UPS draws power from the battery system to supply the load until the batteries are depleted. When the UPS reaches its EOD threshold, it will shut down.

The UPS will automatically restart and enable output power only when the following conditions are met:

1. If the UPS Auto Restart function is enabled.
2. After the Auto Restart delay has expired (default: 10s). During the Auto Restart delay, the UPS will charge the battery in order to provide a safety margin for equipment shutdown if input power fails again.
3. If the Auto Restart function is disabled, you can restart the UPS manually by pressing the power button.

NOTE: During the automatic restart process, manual startup is disabled. Automatic restart must be set by Vertiv engineer through Vertiv setting software.

5.10 Selecting Language

The LCD menus are available in 13 languages.

Procedures for selecting the language:



1. Access the main menu screen and press the  or  key to switch the cursor to select 'Settings', then press the  key to confirm it. See [Figure 5-12](#).

Figure 5-12 Main menu



2. Press the  key to move the cursor to 'Monitor', see [Figure 5-13](#).

Figure 5-13 Monitor interface

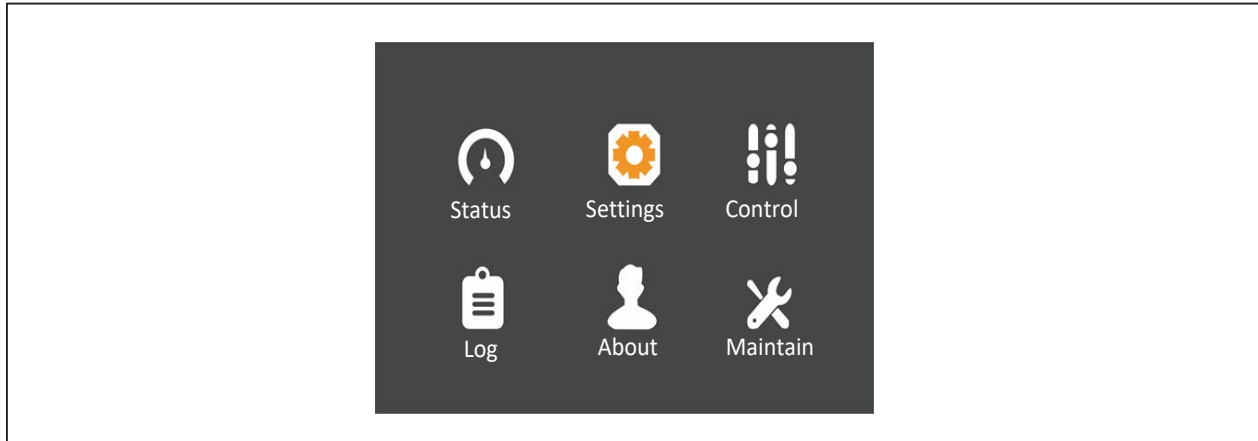

- Press the **Enter** key to highlight the language, see [Figure 5-14](#).

Figure 5-14 Language selection

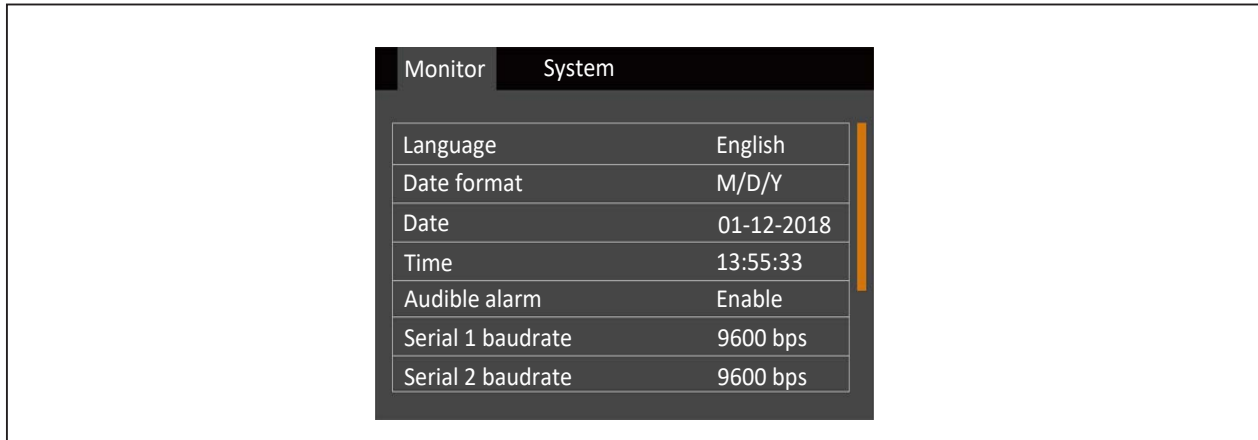
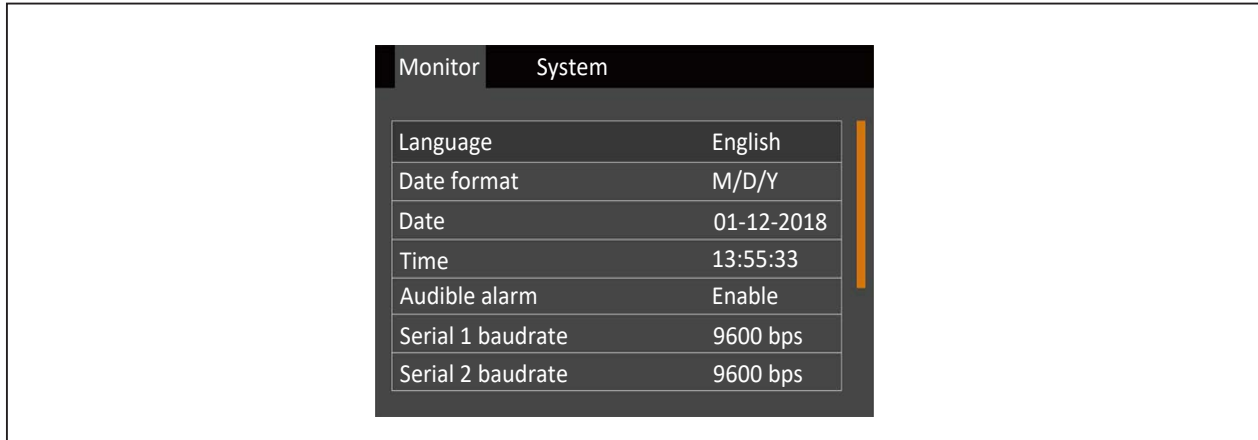

- Press the **↑** or **↓** key to select your required language, then press the **Enter** key to confirm it. At this point, the LCD information will be the displayed in your selected language. See [Figure 5-15](#)

Figure 5-15 Changing Language

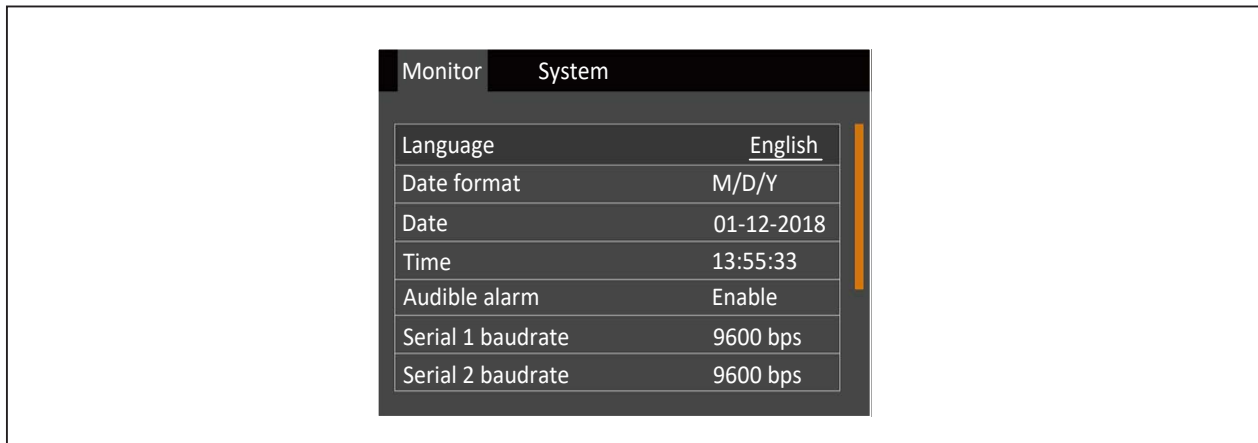

- Press the **Esc** key several times to back to the main menu screen.

5.11 Changing Current Date and Time

Procedures for changing the system date and time:

- Access the main menu screen and press the **↑** or **↓** key to switch the cursor to select 'Settings', then press the **Enter** key to confirm it. See [Figure 5-16](#).

Figure 5-16 Main menu screen

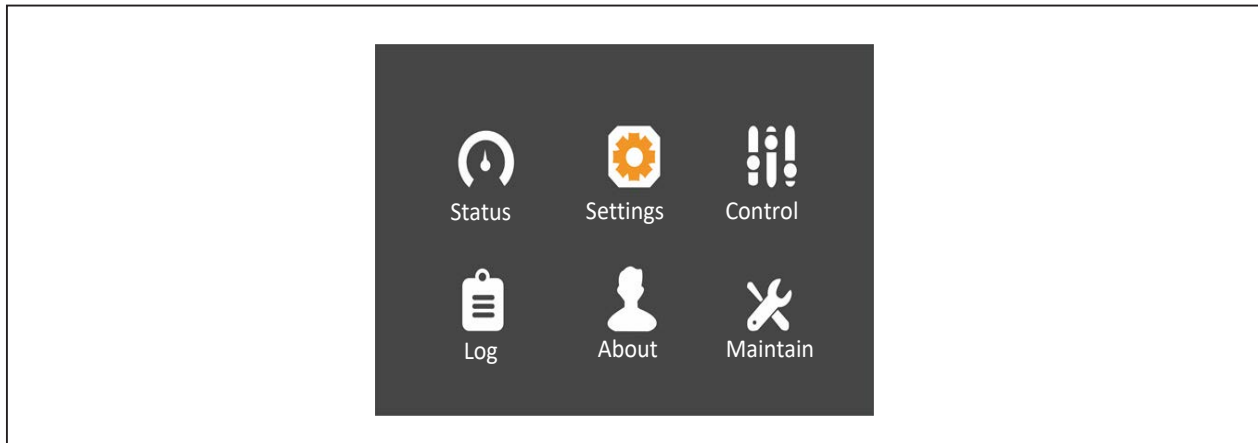

2. Press the  key to move the cursor to 'Monitor', see [Figure 5-17](#).

Figure 5-17 Monitor interface



3. Press the  key, and press the  or  key to highlight the date and time, see [Figure 5-18](#).

Figure 5-18 Selection of date and time

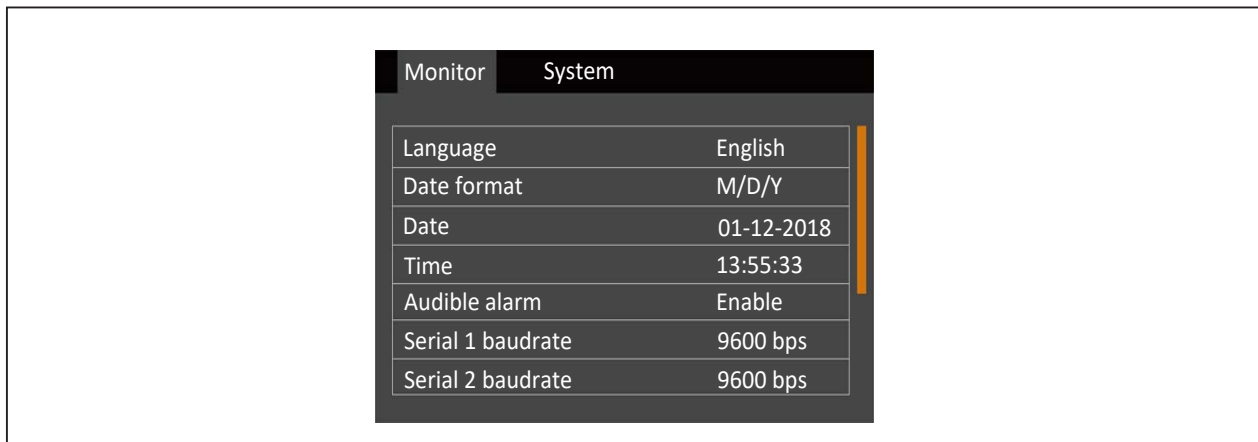
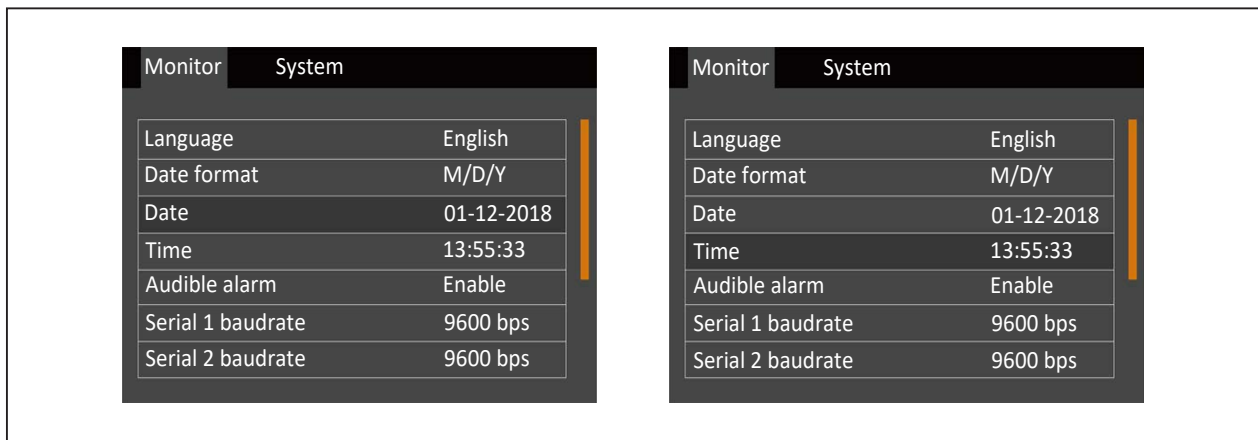

- Press the **Enter** key, move the cursor and press the **▲** or **▼** key to change the date and time as required. See [Figure 5-19](#).

Figure 5-19 Changing date and time

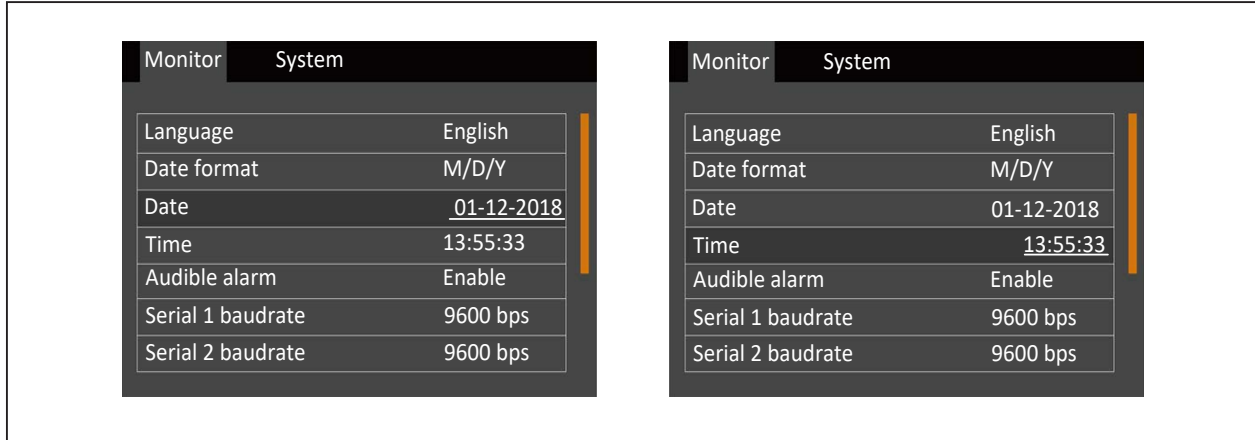

- Press the **Enter** key to confirm it, and then press the **Esc** key several times to back to the main menu screen.

5.12 Setting Password

- After switching the UPS on, access the main menu screen and press the **▲** or **▼** key to move the cursor to select 'Settings'. See [Figure 5-20](#).

Figure 5-20 Main menu

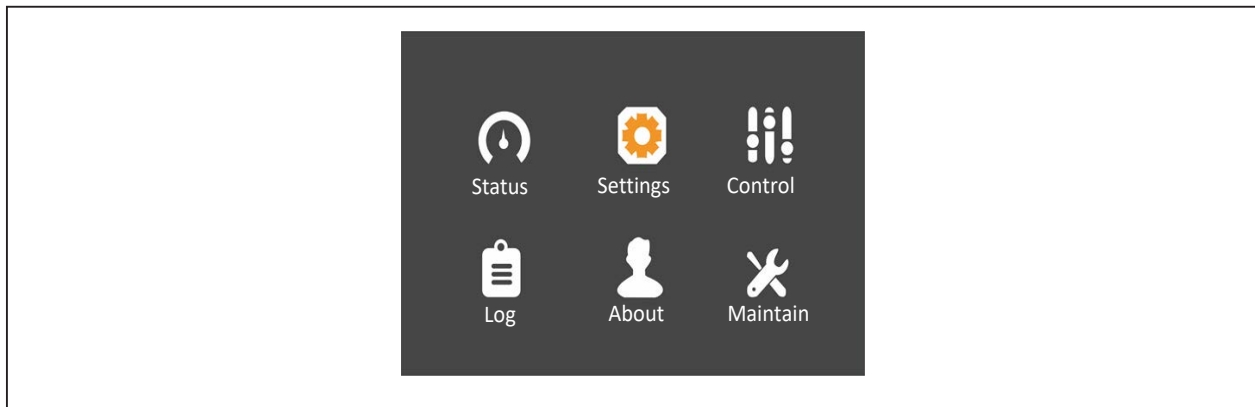

2. Press the  key, the interface shown in [Figure 5-21](#) will appear.

Figure 5-21 Inputting password



To change the password, proceed as follows:

1. Press the  key to move the cursor to the 'Monitor' interface, see [Figure 5-22](#).

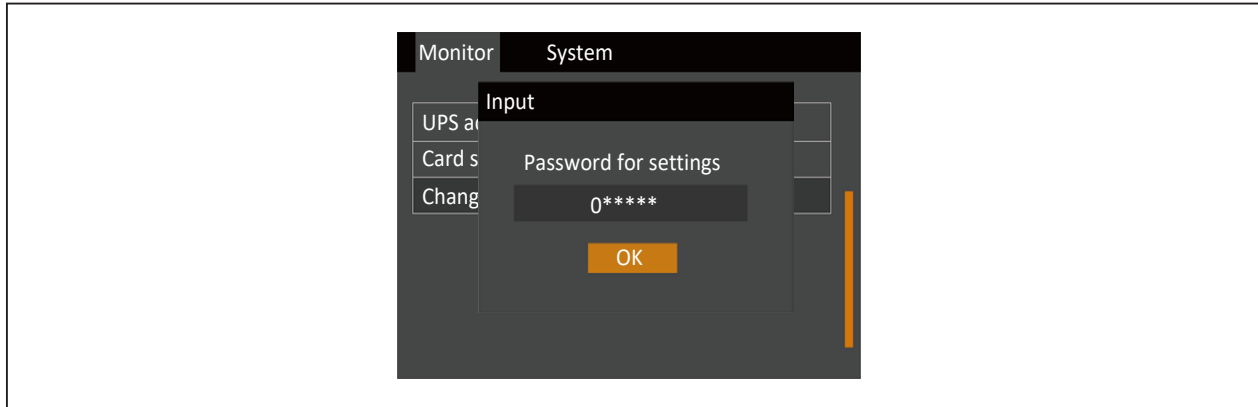
Figure 5-22 Monitor interface



2. Press the  key, then press the  key to select 'Change settings password', see [Figure 5-23](#).

Figure 5-23 Changing settings password

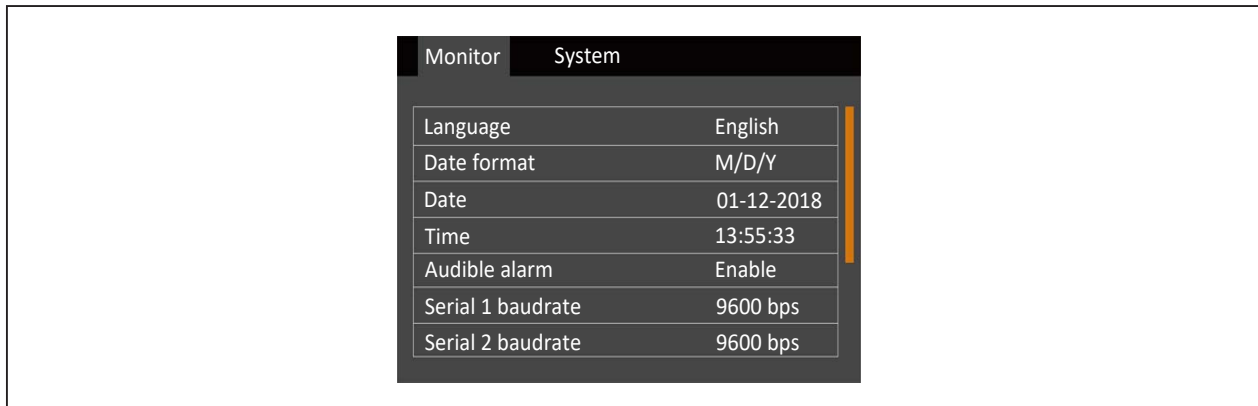

- Press the  key, the interface shown in [Figure 5-24](#) will appear.

Figure 5-24 Password for settings

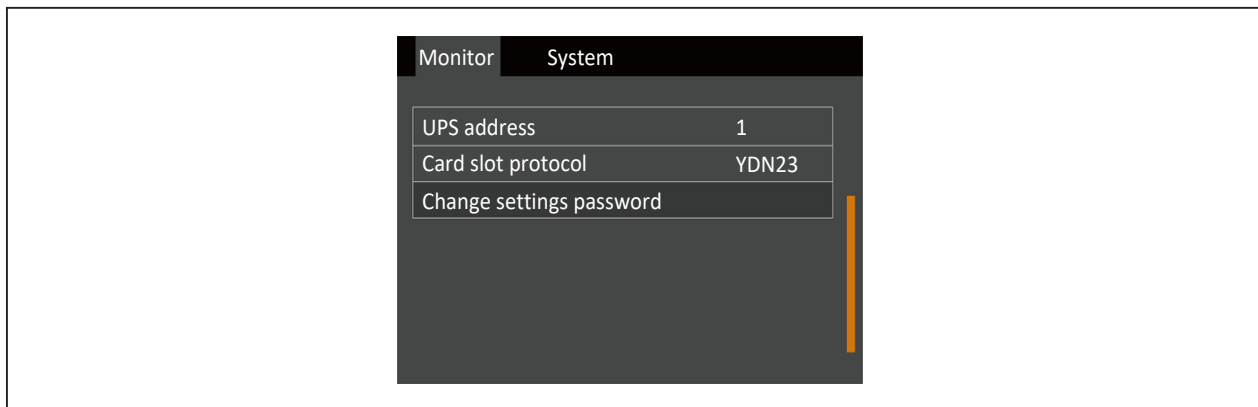

- Enter the current password and press the  key to confirm; at this point the system requests the user to enter a new password. See [Figure 5-25](#).

Figure 5-25 Inputting new password

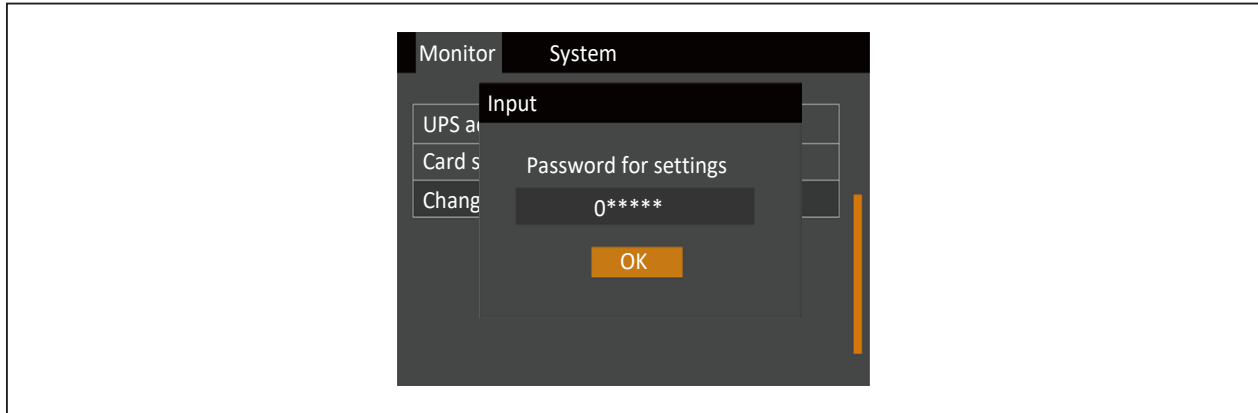

- After entering the new password, press the  key to confirm it; at this point the system requests the user to confirm the new password by entering it again, see [Figure 5-26](#).

Figure 5-26 Confirming new password

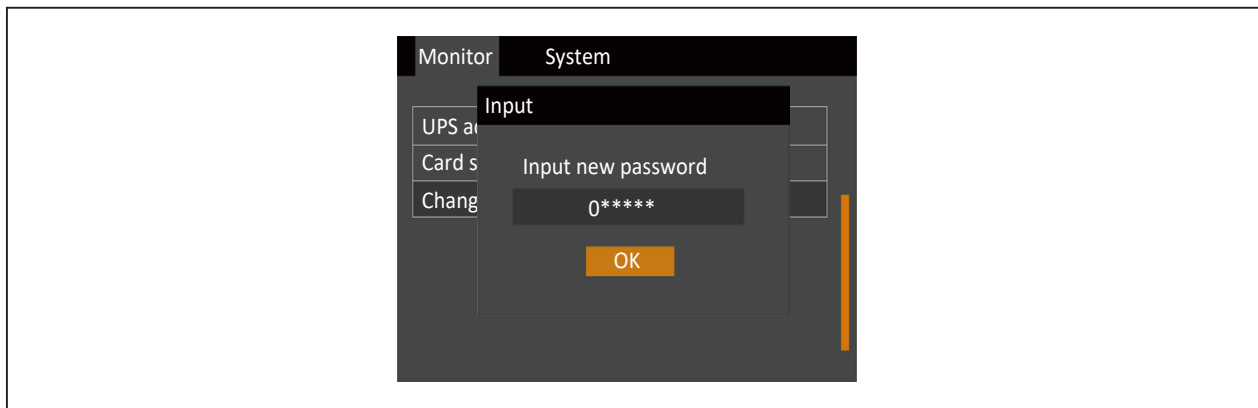

6. After confirming the new password, press the **Enter** key; at this point a system prompt appears indicating that the password has been changed successfully, see [Figure 5-27](#).

Figure 5-27 Password changed successfully

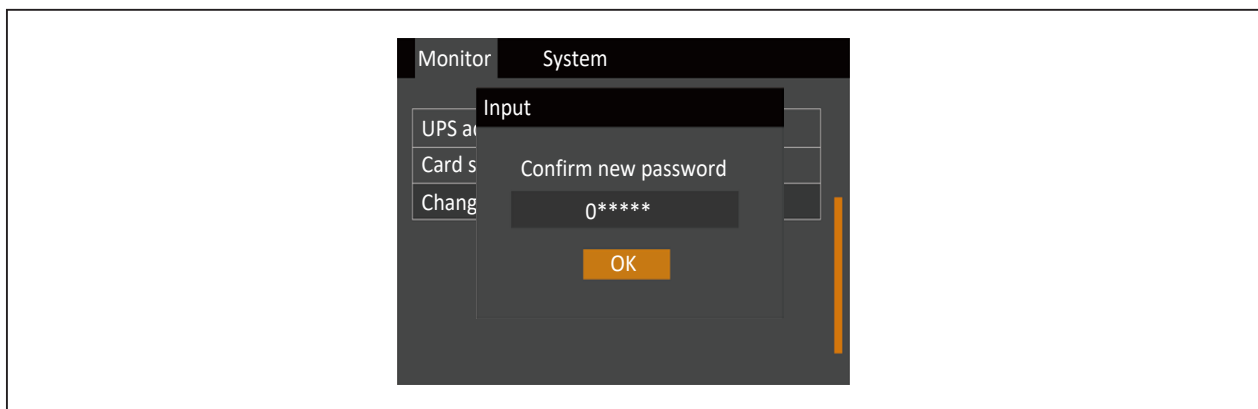
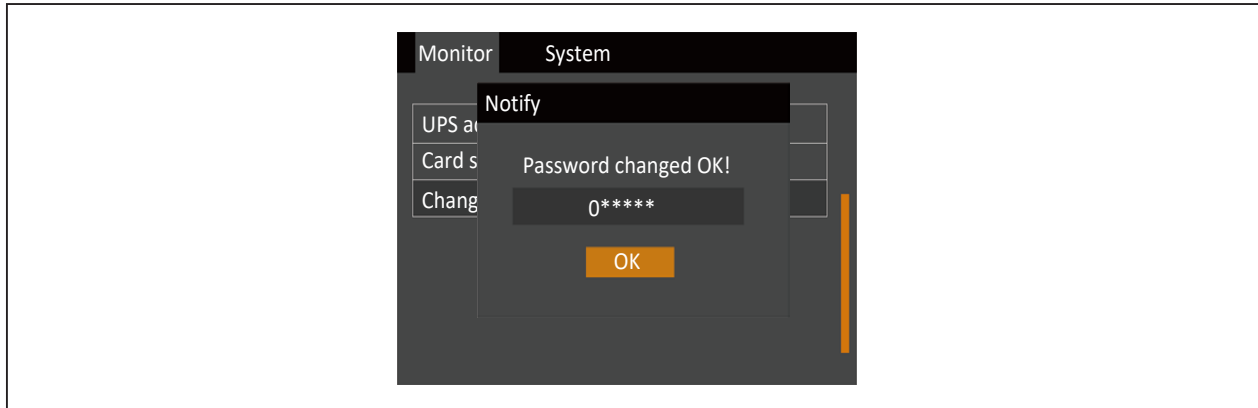

7. Press the **Enter** key several times to back to the main menu screen.

NOTE: In order to access the UPS parameters, it is necessary to enter the correct password (Default: 11111).

6 Parallel System and LBS System

This chapter gives details on the installation of parallel system and LBS system.

6.1 General

The UPS parallel system consists of up to four single UPS of the same model. The parallel system does not require a centralized bypass. Instead the bypass of each UPS shares the load when the system transfers to the mains bypass supply.

From a 'power' viewpoint, each module is internally identical to the 'single module' configuration. A parallel system requires inter-module control signals to manage the load sharing, synchronizing and bypass switching. The control signals are connected through the parallel cables, which are multi-way ribbon cables connected between the units of the system to form a ring.

When two or more modules are to be connected in parallel, it is recommended that inductor should be inserted in the bypass line. This can be installed internal to the UPS as an option.

6.2 Requirements

A UPS system composed of multiple parallel-connected UPSs is equivalent to a large UPS system. Nevertheless, it provides increased system reliability. To ensure equal utilization of all UPSs and compliance with relevant wiring regulations, the following requirements must be met:

1. All single UPSs must have the same capacity.
2. The bypass input power and the rectifier input power must be connected to the same neutral line input terminal.
3. If a residual current detector (RCD) is required, it must be set correctly and installed before the same neutral line input terminal, or it must monitor the protective earth current of the system. Refer to 'Warning: high leakage current' of Safety Precautions before Contents.
4. The outputs of all single UPSs must be connected to the same output bus.

6.3 System Installation Procedures

The basic installation procedure of a parallel system comprising two or more UPS modules is the same as that of single module system. This section only introduces the installation procedures specific to the parallel system. The installation of a parallel UPS should follow the installation procedure for a single UPS module with the additional requirements detailed in this section.



WARNING! To achieve normal operation of the parallel system, Vertiv service personnel must execute the CAN resistance operation. Failure to do so could result in system fault.

6.3.1. Preliminary Checks

Make sure that correct parallel cable option has been selected, and that the module ratings, model, and software and hardware releases are consistent.

! WARNING! To achieve coordinated operation of the modules in the parallel system, it is required to configure each module separately using Vertiv setting software. This must be done by Vertiv service personnel.

6.3.2. Cabinet Installation

Place the UPS modules side by side and interconnect as shown in Figure 6-1. The output distribution mode (QE1, QE2 must be configured) shown in Figure 6-1 is recommended to facilitate maintenance and system testing.

Figure 6-1 Schematic of typical parallel system (with common input, separate batteries and output)

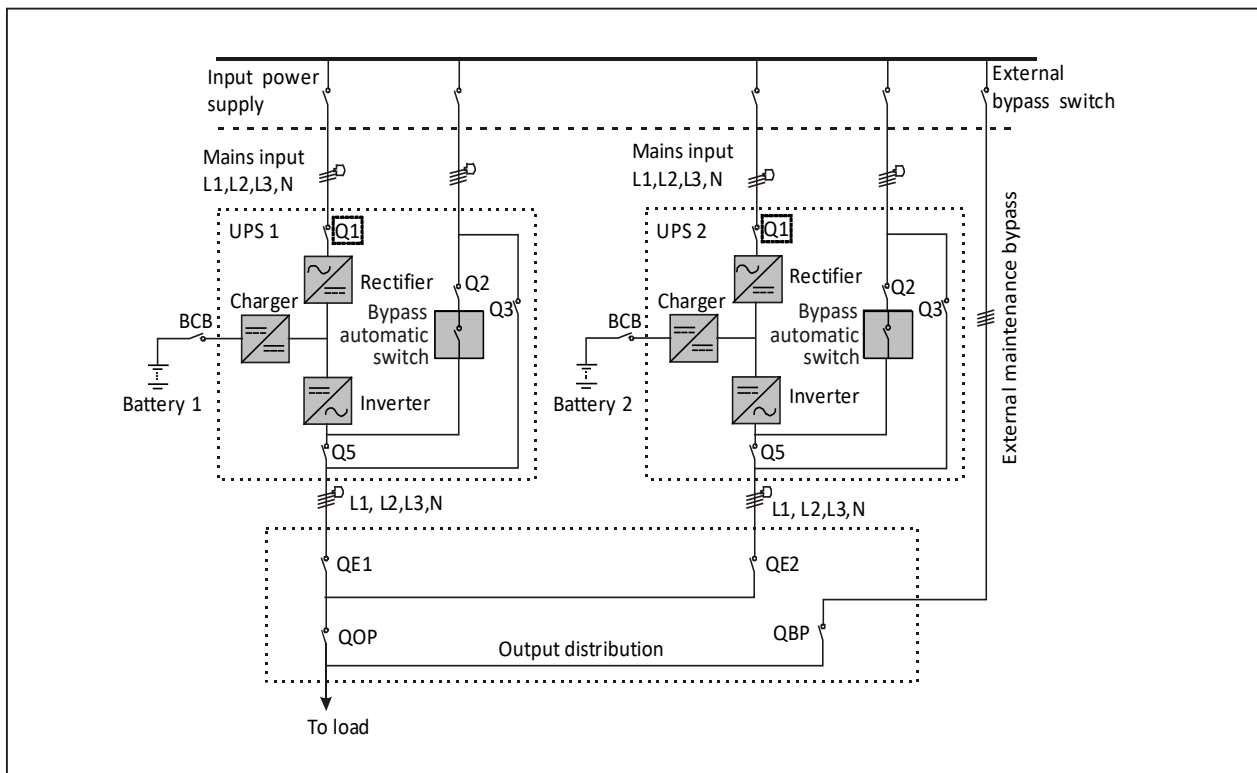

6.3.3. Power Cables

The power cable wiring is similar to that of the UPS module. Refer to [3.1 Wiring of Power Cable](#).

The bypass and rectifier input supplies must use the same neutral line input terminal. If the input has a current leakage protective device, the current leakage protective device must be fitted upstream of the neutral line input terminal.

NOTE: 1. The power cables (including the bypass input cables and UPS output cables) of each UPS module should be of the same length and specifications to facilitate load sharing.
2. The UPS adopts common input configuration and split bypass configuration. If the mains input and bypass input come from two different transformers, then these two transformers should share one grounding grid.

6.3.4. Parallel Cables

Shielded and double-insulated parallel cables available in lengths 5m, 10m and 15m must be interconnected in a ring configuration between the UPS modules, as shown in Figure 6-2. Method: connect a single module parallel cable from its PARALLEL1 port to the PARALLEL2 port of another module. Repeat this step for all the other parallel cables.

The ring connection ensures the reliability of the control of the parallel system. Be sure to verify that the cables are connected securely before starting up the system!

Figure 6-2 Parallel cables connection

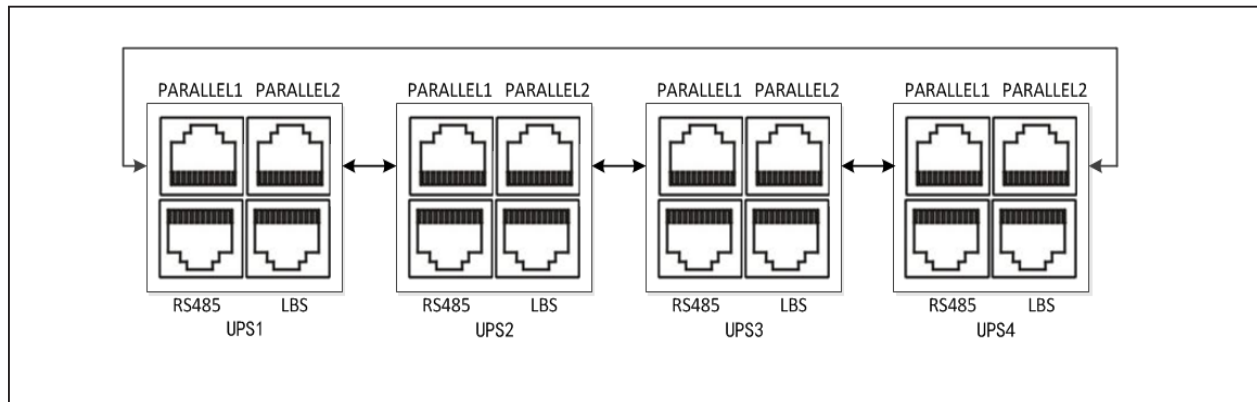

6.3.5. Remote EPO

In addition to the EPO terminal provided from each UPS module for controlling the EPO of each module respectively, the parallel system also provides remote EPO function for controlling all UPS modules to shut down simultaneously from a remote terminal, as shown in [Figure 6-3](#).

NOTE: 1. The remote EPO switch must provide dry contact signal, which is normally open or normally closed.
2. The external EPO device can be composed of another control system which can disconnect UPS mains supply or bypass input.

Figure 6-3 EPO circuit diagram

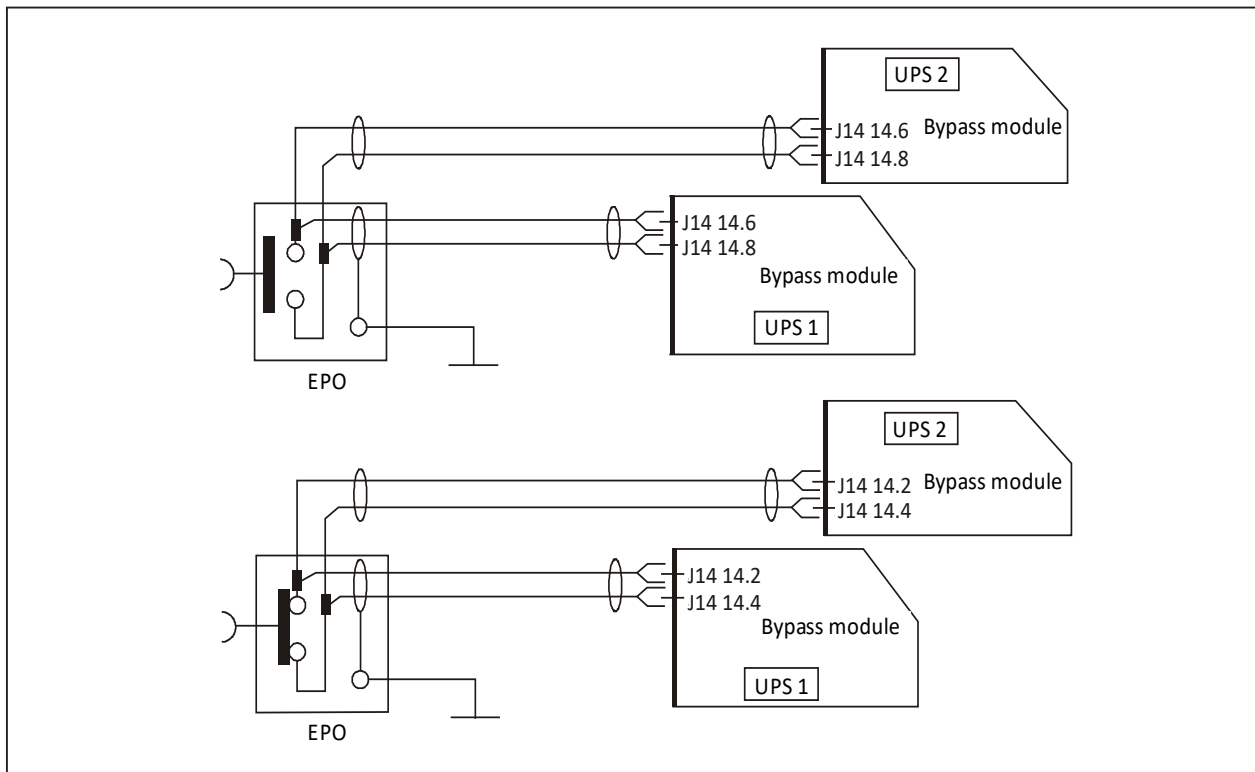

NOTE: In Figure 6-3, the upper one is Normally Open type, and the lower one is Normally Closed type.

6.4 Operation Procedures for Parallel System

6.4.1. Check before Start-up

1. Check and confirm that the UPS power distribution mode is correct, that the power cables and signal cables are connected correctly, and there are no short circuits.
2. Check that the batteries have been installed properly, the cables have been connected correctly, and that the positive and negative battery poles are correct.
3. Check all the working status of the parallel system, ensure that the phase sequence of the main, bypass and output of each UPS is correct and consistent, that the connection of the parallel cable is reliable, and that the user load is not connected during power-on.
4. Measure the mains voltage and frequency, and verify that they are correct.
5. The UPS output terminals are energized when the UPS is switched on. If the load has been already connected to the output terminals, make sure that it is safe to apply power to it.



WARNING! 1. These procedures result in mains voltage being applied to the UPS output terminals.

2. If any load equipment is connected to the UPS output terminals, check with the user that it is safe to apply power. If the load is not ready to receive power, disconnect the downstream load switch, and stick a warning label on the connection point of the load.

6.4.2. Parallel System Parameters Setting

NOTE: The parameters of parallel system must be set by Vertiv engineer through Vertiv setting software

6.4.3. Power-on Procedures for Parallel System

1. Set the parallel parameter of each UPS in the parallel system, then commission the inverter.

The specific commissioning procedures are as follows:

- a. Make sure that the total external maintenance bypass switches in the parallel system are open. Open the front door of each UPS, ensure that the internal maintenance bypass switch Q3 is off, and that the input cables and PE terminals are connected securely.



WARNING! To avoid misreporting as faults, all operations relating to disconnection or connection of the maintenance bypass switch shall be finished within three seconds.

- b. Close the total bypass input switch Q2.
- c. Close the output switch Q5, bypass input switch Q2, main input switch Q1 and all the external output isolating switches (if any) in turn. At the moment, the system is powered on, and LCD screen is activated. See [4.2.1. Start-up Screen](#).
- d. The UPS internal cooling fan starts, and the rectifier executes self-check and starts to run (see [Figure 5-2](#) for power flow page). The rectifier runs in normal state for about 30 seconds, after which the rectifier start-up phase is complete. Please confirm that the LCD displays bypass and main input normally, and that the current log window generates an alarm of 'PowerCAN Comms. Abnormal' or 'Discrete Bus Comms. Abnormal', otherwise you should check that the switch Q2 and switch Q1 have been closed, and that parallel cables of each UPS have been well connected. The alarm indicators (red) are off at all times till all the UPSs in parallel system are rectified.
- e. Refer to [6.4.2. Parallel System Parameters Setting](#) for the parallel parameters setting for each UPS. Carry out the following procedures if the UPS is running normally.
- f. Press the power button of one UPS, and press the Enter key to start the UPS. The run indicator (green) will blink, and the inverter will start, then the run indicator will be on. If the battery is not connected, the alarm indicator will be solid on, and the buzzer will beep every second. If the battery is connected, the alarm indicator will turn off.
- g. If the UPS is working normally, press the power button of this UPS for two seconds to turn off the inverter.
- h. Repeat the preceding step a) ~ step g) to power on and commission the inverter of other UPSs respectively.

NOTE: Carry out the parallel commissioning after each UPS is working normally.

2. After confirming that the inverter of each UPS is normal, commission the parallel system, the specific procedures are as follows:
 - a. Close the external and internal I/O switch of each UPS, and all UPSs are powered on at the same time. After the start of the rectifier is finished, press the power button of one UPS to start the inverter, and then the run indicator (green) will be on.
 - b. Start the inverter of the second UPS, check whether there is an alarm on the LCD, and confirm that the UPS parallel works normally.
 - c. Follow the methods to start inverter of the third or the fourth UPS to connect the UPS into the parallel system.



WARNING! 1. During the parallel power-on, confirm that the external output MCB of each UPS has been closed, and that all the inverter output of the UPSs is connected parallelly.
2. During the parallel power-on, confirm that the system is working normally, and then feed power to the load, to void load power failure.

6.4.4. Maintenance Bypass Procedures



WARNING! If the UPS system is composed of more than 2 parallel UPS modules, and the load capacity exceeds the single module capacity, do not use the internal maintenance bypass switch.

This operation will make the load transfer from UPS power supply protection state to direct connection with AC input bypass state.



CAUTION: Power supply interruption danger of the load
Before performing this procedure, you should check the LCD information first, and make sure the bypass is normal and inverter synchronized. Otherwise, it may result in the load power interruption for a while.

1. Press the power button of each UPS to shut down the inverter, till all the UPSs in parallel system transfer to Bypass mode.
2. Close the UPS external total maintenance bypass switches, and do not close the internal maintenance bypass switch Q3 of each UPS.
3. At this moment, the external total maintenance bypass should be parallel connected with each UPS's bypass.
4. At this moment, the LCD of each UPS displays ' Maint. Switch Closed'.



CAUTION: When the UPS is in maintenance mode, the load does not have the mains abnormal protection.

5. Press the remote EPO button of each UPS for 2s (if any), or unplug the EPO terminal of each UPS to stop the operation of rectifier, inverter, bypass and battery, but this action will not affect the maintenance bypass power the load normally.

NOTE: In maintenance mode, the load is directly fed by the mains power instead of the pure AC power from the inverter.

6. Disconnect the main input switch Q1, bypass input switch Q2, output switch Q5 of each UPS in turn.

At the moment, all the internal power supply is off and the LCD does not display any more.



WARNING! 1. If the maintenance is required, wait 10 minutes for the internal DC bus capacitance discharging.
2. The parts of UPS circuits also have hazardous voltage, though the rectifier input switch, bypass input switch and battery switch are disconnected. Therefore, the UPS maintenance is applicable to qualified personnel only.

6.4.5. Procedures for Isolating One UPS Module from Parallel System



IMPORTANT! These procedures shall only be carried out by service personnel of Vertiv or under their guidance.



WARNING! Before operation, confirm that the system capacity has redundancy to avoid system shutdown due to overload.

The following procedures apply when one UPS module must be isolated from the parallel system for repair due to serious fault:

1. Unplugging the EPO terminal stops the operation of rectifier, inverter, bypass and battery, but this action will not affect other UPSs in parallel system to power the load normally.
2. Disconnect the main input switch Q1, bypass input switch Q2, output switch Q5 of the UPS. At the moment, all the internal power supply is off and the LCD does not display any more.



WARNING! 1. Post a label at the AC input distribution (generally far away from the UPS) to alert that the UPS maintenance is being operated.
2. Wait 10 minutes for the internal DC bus capacitance discharging. Then the UPS is completely shut down.

6.4.6. Procedures for Inserting One Isolated UPS Module in Parallel System



IMPORTANT! These procedures shall only be carried out by service personnel of Vertiv or under their guidance.

The following procedures are used to reintegrate a UPS module that has been previously isolated from the parallel system:

1. The UPS internal cooling fan starts, and the rectifier executes self-check and starts to run (see [Figure 5-2](#) for power flow page). The rectifier runs in normal state for about 30 seconds, after which the rectifier start-up phase is complete. Please confirm that the LCD displays bypass and main input normally, and that the current log window generates an alarm of 'PowerCAN Comms. Abnormal' or 'Discrete Bus Comms. Abnormal', otherwise you should check that the switch Q2 and switch Q1 have been closed, and that parallel cables of each UPS have been well connected.
2. Refer to [6.4.2. Parallel System Parameters Setting](#) for the parallel parameters setting for each UPS. Carry out the following procedures if the UPS is running normally.
3. Press the power button of one UPS, and press the Enter key to start the UPS. Then the run indicator will be on.
4. After this UPS runs in Inverter mode, close the external output switch (if any), and connect this UPS to the parallel system.

6.4.7.6.4.7 Procedures for Completely Powering down UPS

Complete UPS shutdown and load power-off should follow this procedure. All power switches, isolating switches and breakers are disconnected, and then UPS no longer supplies power to the load.



CAUTION:The following procedures will cut off the load power, making the load completely power off.

1. Press the remote EPO button of each UPS for 2s (if any), or unplug the EPO terminal of each UPS to stop the operation of all the rectifiers, inverters, bypasses and batteries.
2. If the UPS is equipped with an external battery, set the corresponding external battery switch to off.
3. Disconnect the main input switch Q1, bypass input switch Q2, output switch Q5 of each UPS. At the moment, all the internal power supply is closed and the LCD does not display any more.



WARNING! Hazardous battery voltage
The battery terminals still have hazardous voltage after the UPS complete shutdown.

6.4.8. Procedures for Complete UPS Shutdown while Maintaining Power to Load

The following procedures are applicable for completely powering down the UPS and still keeping the power supply to the load. Refer to the procedures in [6.4.4. Maintenance Bypass Procedures](#).

6.5 LBS System

6.5.1. Overview

An LBS system consists of two independent UPS systems, each containing one or more parallel UPS modules. The LBS system has high reliability and is applicable to the load with multiple inputs. For single-input load, an STS can be installed to feed power to the load.

6.5.2. Cabinet Installation

The system uses the LBS cables to keep the output of the two independent (or parallel) UPS systems in synchronization. One system is designated as the master, the other is designated as the slave. The operation modes of the parallel system comprise master and/or slave operation in normal or bypass mode. Refer to [Figure 6-4](#) and [Figure 6-5](#) for details.

Figure 6-4 LBS system (UPS module)

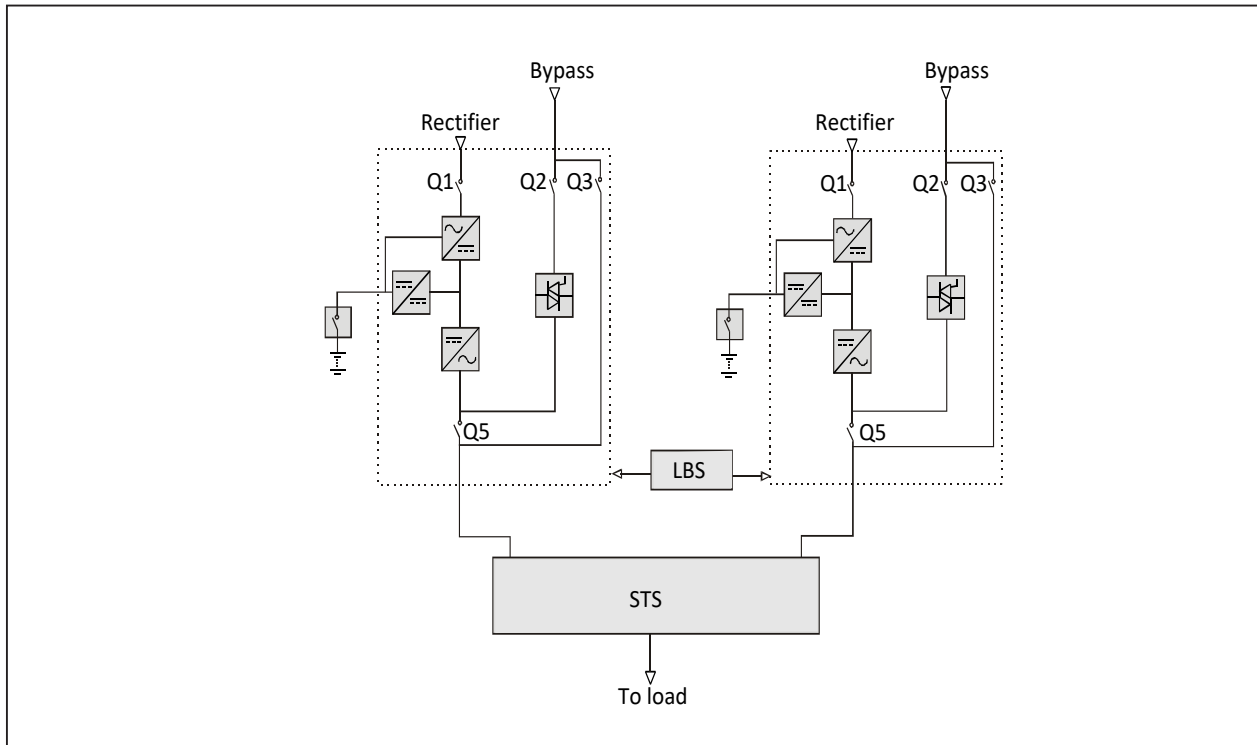
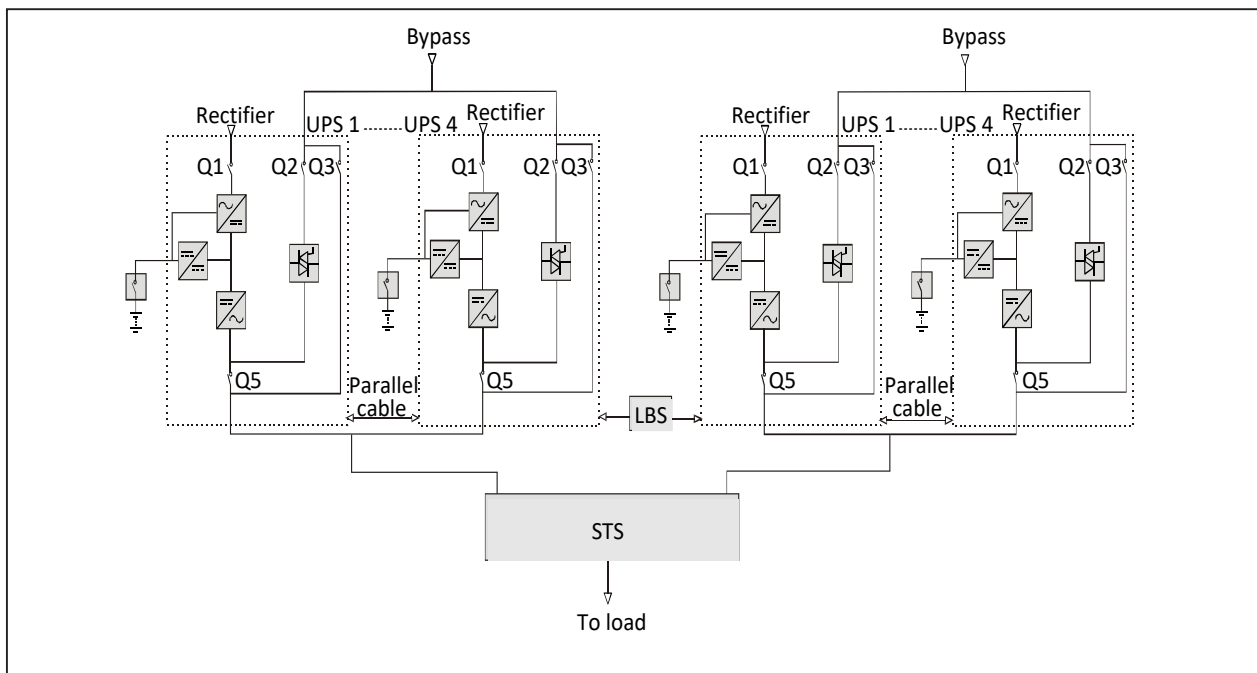

Figure 6-5 LBS system (parallel system)



NOTE: In a dual-bus system, the two UPS systems must have the same power rating, voltage and frequency, and the load should not exceed the power rating of a UPS module system.

6.5.3. Connecting Power Cables

The power cable of dual-bus system is similar to that of single system. Refer to [3.1 Wiring of Power Cable](#).

The bypass and rectifier input supplies must use the same neutral line input terminal. If the input has a current leakage protective device, the current leakage protective device must be fitted upstream of the neutral line input terminal.

6.5.4. Connecting LBS Cables

Connect the shielded and double-insulated LBS optional cables (5m, 10m and 15m) between the LBS port of the two UPS systems shown in [Figure 6-6](#) to [Figure 6-7](#).

Figure 6-6 Connection of typical LBS system (UPS module)

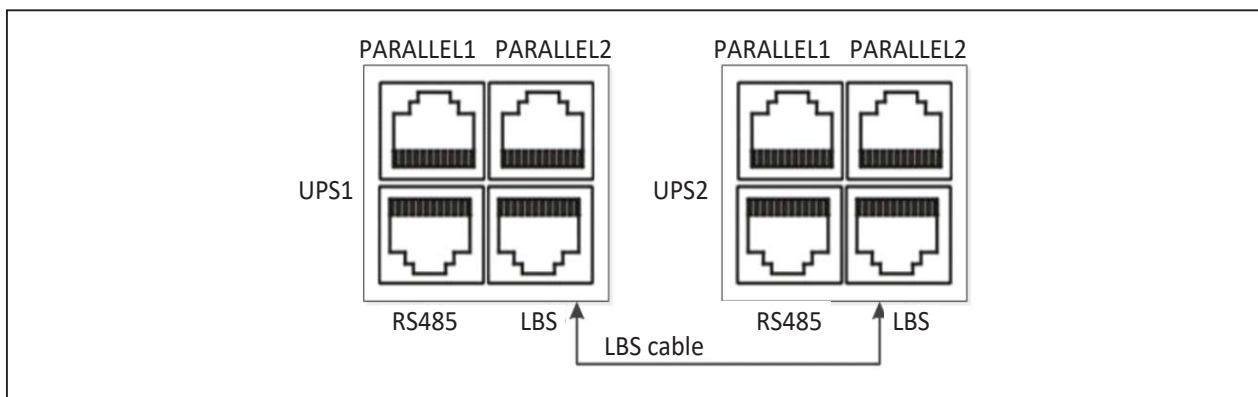
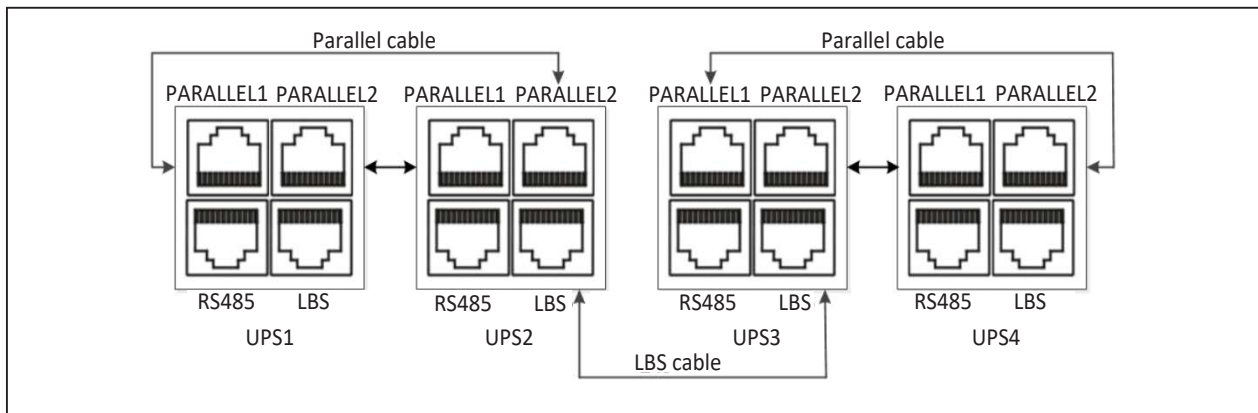

Figure 6-7 Connection of typical LBS system (parallel system)



6.5.5. LBS Parameters Setting

NOTE: The parameters of LBS parameters must be set by Vertiv engineer through Vertiv setting software

6.5.6. LBS System Commissioning

Refer to [6.4 Operation Procedures for Parallel System](#) for details.

7 Communication

This chapter briefly introduces the UPS communication.

The communication ports include: intelligent card port, dry contact port, monitoring port, CAN port, built-in port, LBS port, parallel port, intelligent temperature sensor port and battery monitor port.

7.1 Installing Intelligent Card

7.1.1. Intelligent Card Port

The UPS provides two Intellislot ports (see [Figure 7-1](#)) to install the intelligent cards on site. Open the front door of the UPS, you can see the protective cover located on the cabinet left side. Remove the protective cover to install communication device options, including SIC card, IS-UNITY-DP card, IS-UNITY-LIFE card, and IS-RELAY card.

Figure 7-1 intelligent card installation

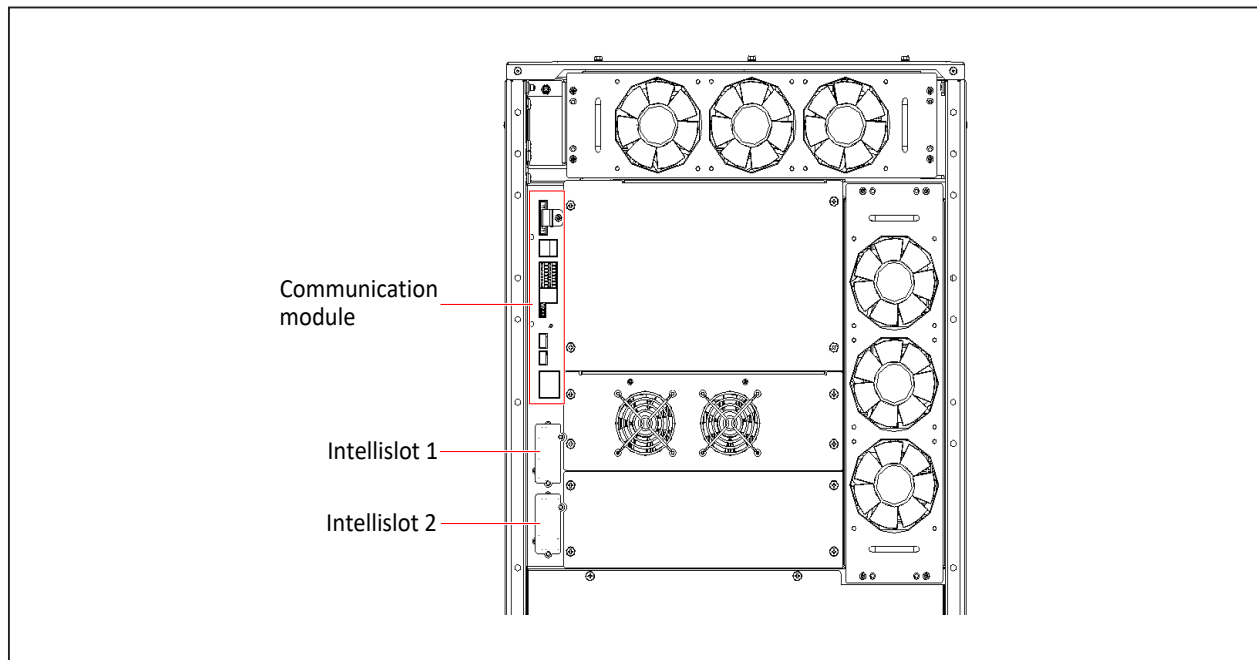

7.1.2. Intelligent Card Option

SIC card

SIC card (see [Figure 7-2](#)) is a network management card, which makes the intelligent devices (such as UPS) produced by Vertiv have network communication capability. For more information of the SIC card, refer to Site Interface Web/SNMP Agent Card User Manual.

Figure 7-2 SIC card

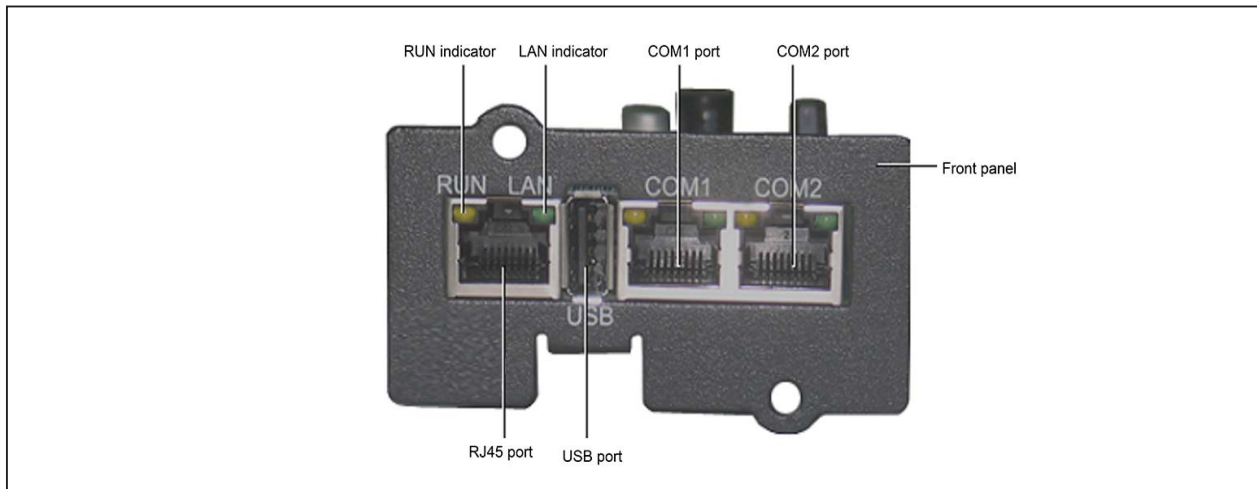

IS-UNITY-DP card

See [Figure 7-3](#) for the appearance of IN-UNITY-DP card.

Figure 7-3 IS-UNITY-DP card



For further description of the IS-UNITY-DP card, refer to Liebert IntelliSlot™ Unity Card User Manual-Web, SNMP, Modbus, BACnet, YDN23.

IS-UNITY-LIFE card

See [Figure 7-4](#) for the appearance of IN-UNITY-LIFE card.

Figure 7-4 IS-UNITY-LIFE card

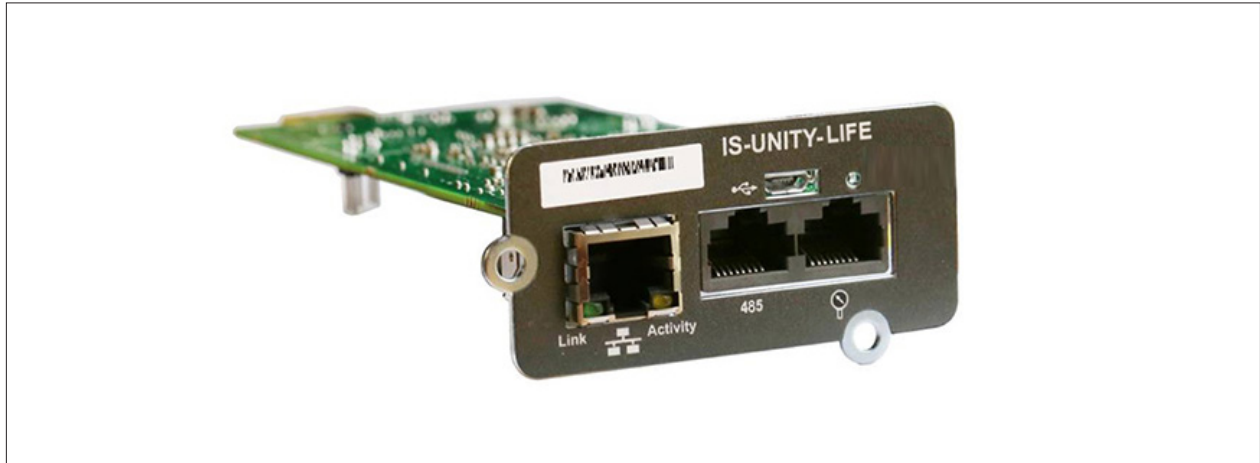

For further description of the IS-UNITY-LIFE card, refer to Liebert IntelliSlot™ Unity Card User Manual-Web, SNMP, Modbus, BACnet, YDN23.

IS-RELAY card

The appearance of the IS-Relay card is shown in [Figure 7-5](#).

Figure 7-5 IS-RELAY card



For more information of the IS-Relay card, refer to the Liebert IntelliSlot IS-Relay Card User Manual.

UF-RS85 card

The UF-RS485 card converts RS232 signal to RS485 signal to realize UPS networking and communication. It should be installed in an Intellislot port of the UPS. It is hot pluggable for easy installation.

Appearance

The appearance of the UF-RS485 card is shown in [Figure 7-6](#).

Figure 7-6 Appearance of UF-RS485 card

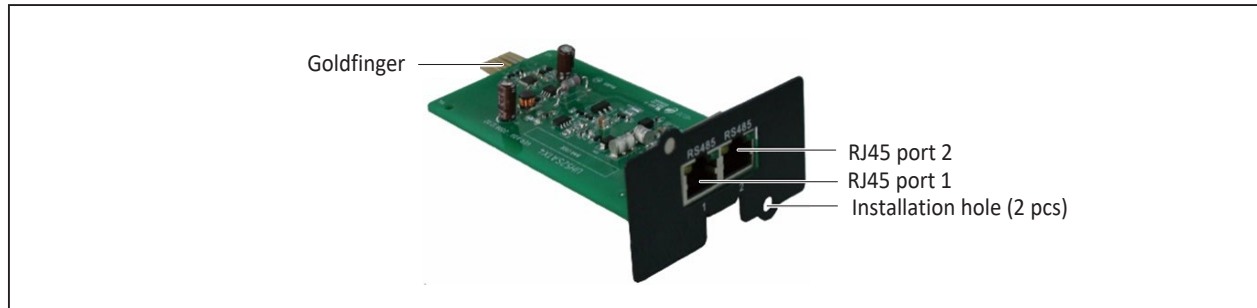

The goldfinger is used for insertion into the Intellislot port of the UPS. It provides RS232 input signal. The RJ45 port 1 and RJ45 port 2 are in parallel connection. They provide RS485 output signal.

Installation

NOTE: 1. The UF-RS485 card is hot-pluggable, so you can install it without shutting down the UPS. 2. Some electronic components on the UF-RS485 card are quite sensitive to static electricity. To prevent static electricity from damaging the card, do not touch its electronic components or circuits with hands or other live objects. Please hold the side edges of the UF-RS485 card when moving or installing it.

1. Insert the UF-RS485 card into the UPS.
 - a. Remove the Intellislot port cover on the front panel of the bypass module. Save the screws.
 - b. Align the UF-RS485 card with the Intellislot port, insert the card into the port along the grooves on both sides of the port.
 - c. Fix the UF-RS485 card through the fixing holes on the UF-RS485 card panel with the screws obtained when removing the Intellislot port cover previously.
2. Connect the cable. Users can select a standard network cable in proper length as the connecting cable according to needs.
 - a. Insert one end of the standard network cable into the RJ45 port 1 or RJ45 port 2 of the UF-RS485 card.
 - b. Insert the other end of the standard network cable to the corresponding port of the user equipment.



WARNING! 1. The RJ45 ports of the UF-RS485 card must connect to SELV circuit. Failure to observe this could cause damage to the card and even result in safety accidents. 2. The connecting cable of the UF-RS485 card and the external equipment must be a double-end shielded cable.

Troubleshooting

Fault: The UF-RS485 output signal does not change with the UPS status.

Action to take: Ensure that the UF-RS485 card is properly inserted into the Intellislot port and the cable is properly connected.

7.1.3. Installation Procedures



WARNING! Some electron components in the intelligent card are sensitive to static, therefore, do not touch the electron components or circuit in the intelligent card by hand or other conductive materials, so as to protect the intelligent card against static shock. When removing or installing the intelligent card, hold the card side edge to operate it.

1. Remove the protective cover on the UPS intelligent card, retain the screws, and keep the protective cover properly for future use.
2. Insert the intelligent card (along two sides of the Intellislot port) into the port position recommended in Figure 7-1, and then fasten the screws.

NOTE: 1. SIC card, UNITY-DP card, UNITY-LIFE card, and IS-RELAY card can be installed at Intellislot1 or Intellislot2.

2. When installing the UNITY-DP card or the UNITY-LIFE card at Intellislot1 or Intellislot2, if you wish to change the baud rate, just change the 'serial port 2 baudrate' on the operator and display panel.

3. When installing the SIC card at Intellislot2, if you wish to change baud rate, just change the 'serial port 2 baudrate' on the operator and display panel.

4. When installing the SIC card at Intellislot1, if you wish to change the baud rate, you first need to confirm the current communication mode of SIC card is RS232 or RS485 via the SIC card web interface. If RS232 communication mode, it can be realized by changing 'serial port 1 baudrate' on the operator and display panel; if RS485, it can be realized by changing 'serial port 2 baudrate' on the operator and display panel.

5. The path of 'serial port 1 baudrate' and 'serial port 2 baudrate' on the operator and display panel is: main menu screen -> setting -> monitor -> serial port 1 baudrate or serial port 2 baudrate.

6. The path of main menu screen -> setting -> monitor -> UPS address is used to set the communication address of this UPS through the YDN23 protocol.

7. The path of main menu screen -> setting -> monitor -> card slot protocol is used to set the RS485 bus protocol in the two intelligent card ports, and the protocol used is YDN23 or Velocity. The SIC card adopts YDN23 protocol while UNITY-DP card and UNITY-LIFE card adopt Velocity protocol.



IMPORTANT! These procedures shall only be carried out by service personnel of Vertiv or under their guidance.

7.2 Connection Cables for Dry Contact Port

For on-site specific needs, the UPS needs auxiliary connection to realize battery system (including the external battery switch) management, communicate with PC, provide alarm signal to external devices, realize remote EPO or provide bypass back-feed circuit breaker signal and parallel communication. These functions are realized through the communication box in the UPS cabinet. As shown in Figure 7-7, the communication box provides the following ports, and the port description is shown in Table 7-1.

Figure 7-7 Pin layout of dry contact ports

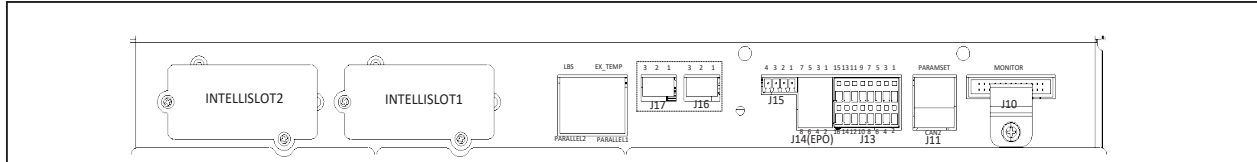

Table 7-1 Description of the dry contact ports

Silkprint	Port name	Pin No.	Pin name	Meaning	Remarks
J11	Communication port	CAN2	CAN communication port	Default	
	Host port	PARAMSET	Paramset port	Communicate with PC, configure the parameters for the UPS via this port	
J13'	Input dry contact	1	EXT_MIB	On Generator / Transfer to Inverter Inhibited / External MIB (default) / External MBB / Module Output Breaker / Battery Ground Fault / Charger Shutdown / ECO Inhibited (Inverter Mode Preferred) / Start Battery Maintenance Self-check / Stop Battery Maintenance Self-check / Alarm Cleared. Pin1 and Pin3 shorted to enable this function	Can configure input dry contact J13-1
		3	GND_SELV		
		5	MOB	On Generator / Transfer to Inverter Inhibited / External MIB / External MBB / Module Output Breaker (default) / Battery Ground Fault / Charger Shutdown / ECO Inhibited (Inverter Mode Preferred) / Start Battery Maintenance Self-check / Stop Battery Maintenance Self-check / Alarm Cleared. Pin5 and Pin7 shorted to enable this function	Configurable input dry contact J13-5
		7	GND_SELV		
		9	EXT_MBB	On Generator / Transfer to Inverter Inhibited / External MIB / External MBB (default) / Module Output Breaker / Battery Ground Fault / Charger Shutdown / ECO Inhibited (Inverter Mode Preferred) / Start Battery Maintenance Self-check / Stop Battery Maintenance Self-check / Alarm Cleared. Pin9 and Pin11 shorted to enable this function	Configurable input dry contact J13-9
		11	GND_SELV		
		13	GEN_MODE	On Generator (default) / Transfer to Inverter Inhibited / External MIB / External MBB / Module Output Breaker / Battery Ground Fault / Charger Shutdown / ECO Inhibited (Inverter Mode Preferred) / Start Battery Maintenance Self-check / Stop Battery Maintenance Self-check / Alarm Cleared. Pin13 and Pin15 shorted to enable this function	Configurable input dry contact J13-13
15	GND_SELV				

Silkprint	Port name	Pin No.	Pin name	Meaning	Remarks
J13 ¹	Input dry contact	2	Inhibit_trans_to_inverter	On Generator / Transfer to Inverter Inhibited (default)/External MIB / External MBB / Module Output Breaker / Battery Ground Fault / Charger Shutdown/ECO Inhibited (Inverter Mode Preferred) /Start Battery Maintenance Self-check/Stop Battery Maintenance Self-check /Alarm Cleared. Pin2 and Pin4 shorted to enable this function	Configurable input dry contact J13-2
		4	GND_SELV		
		6, 8, 10	Default		
		12	TEM_DETECT_CONTROL	Battery temperature detection control	
		14	TEMP_PULSE_IN	Battery temperature detection input	
		16	GND_SELV	GND	
J14 ²	Output dry contact and REPO port	1	On_Battery_A	System Alarm /On Battery (default) /Battery Low Capacity /UPS Fault / On Bypass / UPS /Remote EPO / Main input abnormal / On Maintenance Bypass / Load Shed Signal 1 / Load Shed Signal 2 / Internal MBB Closed. Pin1 and Pin3 shorted for alarm state. Note: We recommend adopting the switch with normally-closed auxiliary contact when load shed signal is selected	Configurable input dry contact J14-1/3
		3	On_Battery_B		
		5	Summary_Alarm_A	System Alarm (default) /On Battery /Battery Low Capacity /UPS Fault / On Bypass / UPS /Remote EPO / Main input abnormal / On Maintenance Bypass / Load Shed Signal 1 / Load Shed Signal 2 / Internal MBB Closed. Pin5 and Pin7 shorted for alarm state. Note: We recommend adopting the switch with normally-closed auxiliary contact when load shed signal is selected	Configurable input dry contact J14-5/7
		7	Summary_Alarm_B		
		2	REPO_NC	Trigger EPO upon Pin2 and Pin4 opened	
		4	+12V_EPO		
		6	+12V_EPO	Trigger EPO upon Pin6 and Pin8 shorted	
		8	REPO_NO		
J15 ²	Battery BCB port	1	BCB_DRIVE	BCB tripping drive, normally 0V, 12V tripping	
		2	BCB_STATUS	BCB switch status signal	
		3	GND_SELV	GND	
		4	BCB_ONLINE	BCB on line	
J16 ³	Rectifier back-feed output port	1	MFP_O	Rectifier back-feed normally open contact. Closed when there is rectifier back-feed	
		2	MFP_S	Rectifier back-feed common contact	
		3	MFP_C	Rectifier back-feed normally closed contact. Open when there is rectifier back-feed	

Silkprint	Port name	Pin No.	Pin name	Meaning	Remarks
J17 ⁴	Bypass back-feed output port	1	BFP_O	Bypass back-feed normally open contact. Closed when there is bypass back-feed	
		2	BFP_S	Bypass back-feed common contact	
		3	BFP_C	Bypass back-feed normally closed contact. Open when there is bypass back-feed	

- NOTE: 1. Capacity of input dry contact port J13: 12Vdc, 20mA.**
2. Capacity of output dry contact ports J14 and J15: 24Vdc, 0.5A.
3. Capacity of output dry contact ports J16 and J17: 250Vac, 5A.
4. If REPO is required: Pin6 and Pin8 are reserved, and Pin2 and Pin4 of J14 are shorted before delivery; If Normally Closed switch is configured as REPO, remove the shorting cable between Pin2 and Pin4, and then adopt the shielded cable to connect Pin2 and Pin4 with the switch; If Normally Open switch is configured as REPO, reserve the shorting cable between Pin2 and Pin4, and then adopt the shielded cable to connect Pin6 and Pin8 with the switch.
5. If configurable input dry contact is configured as ‘Start Battery Maintenance Self-check’ or ‘Stop Battery Maintenance Self-check’ or ‘Alarm Cleared’, the rising edge triggering will be effective; if configurable input dry contact is configured as other functions, the level triggering will be effective.

NOTE: Activating the UPS EPO will close the rectifier, inverter, bypass and battery, but does not disconnect the UPS mains input inside. If you wish to disconnect the UPS completely, it is also necessary to open the internal input switch and unplug the battery terminals when activating the EPO.

In the event of an emergency, trigger the REPO switch (supplied and installed by the user) in order to shut down the rectifier and inverter, and switch the UPS off. Under normal conditions, the REPO switch cannot be used to isolate the UPS from the mains input power. If an electronically controlled circuit breaker function is installed at the UPS input, the REPO switch can be used to trip this breaker, thus cutting off the UPS mains input power. The position of the REPO switch is shown in [Figure 7-7](#), and the REPO cable connection is shown in [Figure 7-8](#) and [Figure 7-9](#).

Figure 7-8 REPO (Normally Closed) cable connection

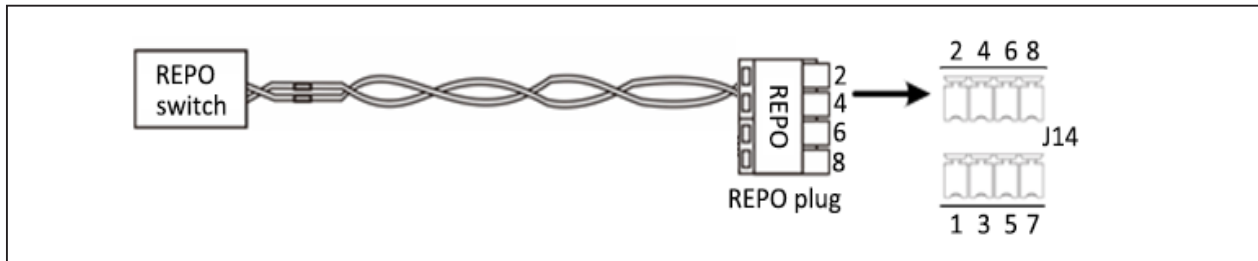
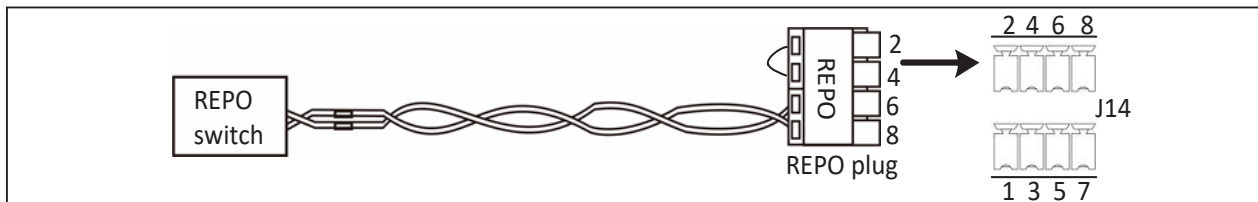

Figure 7-9 REPO (Normally Open) cable connection



NOTICE: 1. Ensure that the plug of REPO have been correctly connected to the corresponding Pin of port J14, and that the REPO cable is connected securely in order to ensure that the REPO is not activated inadvertently as the result of poor contacts.

2. When the REPO switch at the user-end is triggered, the UPS will generate an alarm and cut off the output immediately, and the UPS will not return to the normal operating state automatically. At this point, it is necessary to change the REPO switch state, and switch the UPS on manually.

3. REPO switch is only valid for the specified unit in parallel system.

NOTE 1. We recommend using $0.82 \text{ mm}^2 \sim 0.33 \text{ mm}^2$ signal cable (18AWG~33AWG), the cable length should not be more than 10m.

2. If the REPO has been configured to trip an electronically controlled circuit breaker switch, after the REPO has been activated it will be necessary to re-arm the switch before restarting the UPS.

7.3 Connecting Parallel Cables

See [Figure 7-7](#) for the connection port.

Refer to [Figure 6-2](#) for the connection of parallel cables.

7.4 Connecting LBS Cables

See [Figure 7-8](#) for the connection port.

Refer to [Figure 6-6](#) and [Figure 6-7](#) for the connection of LBS cables.

This page is intentionally left blank.

8 Maintenance

This chapter focuses on the UPS maintenance, including the fan maintenance, battery maintenance, UPS cleaning, UPS state check, UPS function check.

NOTE: Never attempt to carry out maintenance on the UPS while it is on line. Ensure that the UPS has been switched off completely when performing any internal maintenance operations on it.

8.1 Fan Maintenance

NOTE: In order to avoid injury or damaging the device, wait until the fan is completely stationary before inserting fingers or any tools into it.

The UPS fans are expected to run for 20,000 hours ~ 40,000 hours in continuous operation. The higher the ambient temperature, the shorter the fan life.

During the UPS operation, it is important to check the condition of the fans regularly by confirming that they blow air out of the ventilation holes on the rear panel.

8.2 Battery Maintenance

**NOTE: 1. Never invert the battery connections as this could result in fires.
2. Never attempt to open batteries since they contain electrolyte which is potentially harmful to personnel. In the event of accidental with electrolyte, wash the affected area with abundant, clean water, and seek medical assistance immediately.**

The internal battery module of the UPS is sealed, lead-acid, maintenance-free battery. The battery life depends on the ambient temperature, charge and discharge times. High ambient temperature and deep discharge shortens the battery life.

To ensure the battery life, it is required to:

- Keep the ambient temperature ranging from 15 °C to 25 °C
- Prevent small current discharge. Continuous battery operation time exceeding 24 hours is strictly prohibited
- Charge the battery for at least 12 hours, if the battery hasn't been charged for three months at specified ambient temperature, or two months at high ambient temperature

**NOTE: 1. Check the battery connection screws are regular intervals, and re-tighten them if necessary.
2. Make sure that all the safety devices present, in good condition and that they function correctly, and make sure that the battery management parameter settings are correct.
3. Measure and log the ambient temperature in the battery room.
4. Check whether the battery ports are damaged or hot, and check the condition of the chassis and the covers.**

If any of the batteries are found to be leaking, place them in a suitable container and dispose of them in accordance with local regulations.

Lead-acid batteries are classified as hazardous waste material. The control of waste battery pollution is a nationally important issue. Batteries must be stored, transported, used and disposed of in accordance with national and local legal requirements and all other criteria applicable to the treatment of hazardous waste material and waste battery pollution prevention.

According to the applicable regulations, waste lead-acid batteries must be recycled, while all other disposal methods are prohibited. Uncontrolled or random disposal of waste lead-acid batteries, or other improper disposal methods can result in serious environmental pollution, which will be investigated by the relevant authorities.

As the provider of lead-acid batteries, Vertiv has developed a dedicated service network and waste battery recycling system to assist users to dispose of waste batteries legally. Contact Vertiv or your nearest service center for detailed information about the waste battery the recycling system.

Vertiv may not be held liable for the environmental impact resulting from the failure to comply with the guidelines set out in this section, or to use the waste battery recycling system offered by Vertiv.

8.3 Cleaning UPS

Clean the UPS periodically, especially the ventilation holes, to ensure free airflow inside the UPS. If necessary, clean the UPS with a vacuum cleaner. Confirm that the ventilation holes are unobstructed.

8.4 Checking UPS State

We recommend checking the operational state of the UPS regularly.

Check the following items:

1. Check for any UPS fault conditions: Is the alarm indicator on? Are there any UPS alarms active?
2. Check if the UPS is operating in Bypass mode. Under normal conditions, the UPS operates in Normal mode; if you find that it is operating in Bypass mode, determine the reason (operator intervention, overload, internal fault, etc.)
3. Check if the battery is discharging: When the AC mains supply is within normal limits, the battery should not be discharging; if you find that it is operating in Bypass mode, determine the reason (mains failure, battery test, operator intervention, etc.).

8.5 Checking UPS Functions

NOTE: UPS functions check procedures may cause power interruption to load!

We recommend checking the UPS functions regularly.

Backup the load data before conducting the UPS functional check. The procedures are as follows:

1. Press the power button to check if the buzzer beeps, the indicators are on and the LCD display is normal.
2. Press the ESC key and check again that the indicators are on, the LCD display is normal, and that the UPS has been transferred to inverter mode.

9 Options

This chapter introduces the options that are available for the UPS.

9.1 List of Options

See [Table 9-1](#) for the list of the available options.

Table 9-1 List Of options

Option name	External model	Code	Note
UPS parallel cable	EXS 0040kTH16FN01SL10	04113255	UPS parallel cable (5m)
	EXS 0040kTH16FN01SL11	04113256	UPS parallel cable (10m)
	EXS 0040kTH16FN01SL12	04113257	UPS parallel cable (15m)
LBS cable	EXS 0040kTH16FN01SL10	04113255	LBS cable (5m)
	EXS 0040kTH16FN01SL11	04113256	LBS cable (10m)
	EXS 0040kTH16FN01SL12	04113257	LBS cable (15m)
	UF-LBS01-50	0235A04V	LBS extension cable (50m)
	UF-LBS01-150	0235A04Y	LBS extension cable (150m)
SIC card	UF-SNMP810	02351817	Option for intelligent card
IS-RELAY card	IS-RELAY	02351105	Option for intelligent card
IS-UNITY-DP card	IS-UNITY-DP	03020728	
IS-UNITY-LIFE card	IS-UNITY-LIFE	03020753	
RS485 card	UF-RS485	02351786	
External battery temperature sensor kit	IRM-S01T	02311725	
1*40-block 37.5Ah battery cabinet	EXS 0060kBCI02	02010181	Battery included
1*40-block battery cabinet	EXS 0060kBCE01	02010098	Battery excluded
BCB BOX (Built in 315A BCB)	EXS 0060kBCB01	02312434	BCB box, used to connect and control the external battery string
Battery ground fault kit	EXS 0040kBGF01	02312761	Used together with BCB
EMC C2 assembly	EXS 0080kEMC01	02010201	
Output transformer	EXS 0080kOIT01	02010191	Either 02010191 or 02010095
IP31 kit	EXS 0080kIPS01	02010227	
Top fan	EXS 0080kTFS01	02010243	

9.2 Parallel Cables

Communication cable is compulsory in parallel system. See [Table 9-2](#) for cable description. Refer to [6.3.4. Parallel Cables](#) for the methods to connect the parallel cables.

Table 9-2 Description of the parallel cables

Type	Description	Appearance
EXS 0040kTH16FN01SL10	For N + 1 parallel system, N + 1 communication cables (5m) are required. For example, two communication cables are required in 1 + 1 parallel system; three communication cables are required in 2 + 1 parallel system; four communication cables are required in 3 + 1 parallel system	
EXS 0040kTH16FN01SL11	For N + 1 parallel system, N + 1 communication cables (10m) are required	
EXS 0040kTH16FN01SL12	For N + 1 parallel system, N + 1 communication cables (15m) are required	

9.3 LBS Cables

The LBS cables are compulsory in dual bus system. See [Table 9-3](#) for cable description. Refer to [6.5.4. Connecting LBS Cables](#) for the methods to connect the LBS cables

Table 9-3 Description of the LBS cables

Type	Description	Appearance
EXS 0040kTH16FN01SL10	5m parallel/LBS cable	
EXS 0040kTH16FN01SL11	10m parallel/LBS cable	
EXS 0040kTH16FN01SL12	15m parallel/LBS cable	
UF-LBS01-50	LBS assembly (50m cable included)	
UF-LBS01-150	LBS assembly (150m cable included)	

9.4 Communication Options and Temperature Sensor

The communication options and temperature sensor are listed in [Table 9-4](#).

Table 9-4 Communication options and temperature sensor

Name	Type	Description	Appearance
SIC card	UF-SNMP810	Remotely monitor UPS through TCP/IP protocol and Internet; Provide an extended net port, cascade-connect up to eight temperature sensors	
IS-UNITY-DP card	IS-UNITY-DP	For further description of the IS-UNITY-LIFE card, refer to Liebert IntelliSlot™ Unity Card User Manual-Web, SNMP, Modbus, BACnet, YDN23	
IS-UNITY-LIFE card	IS-UNITY-LIFE	For further description of the IS-UNITY-LIFE card, refer to Liebert IntelliSlot™ Unity Card User Manual-Web, SNMP, Modbus, BACnet, YDN23	
IS-RELAY card	UF-DRY410	For more information of the IS-Relay card, refer to the Liebert IntelliSlot IS-Relay Card User Manual	
IS-RELAY card	UF-DRY410	For more information of the IS-Relay card, refer to the Liebert IntelliSlot IS-Relay Card User Manual	
IS-UNITY-DP card	IS-UNITY-DP	For further description of the IS-UNITY-LIFE card, refer to Liebert IntelliSlot™ Unity Card User Manual-Web, SNMP, Modbus, BACnet, YDN23	
IS-UNITY-LIFE card	IS-UNITY-LIFE	For further description of the IS-UNITY-LIFE card, refer to Liebert IntelliSlot™ Unity Card User Manual-Web, SNMP, Modbus, BACnet, YDN23	
IS-RELAY card	UF-DRY410	For more information of the IS-Relay card, refer to the Liebert IntelliSlot IS-Relay Card User Manual	

9.5 BCB Box

9.5.1. Overview

The BCB box contains a BCB and a BCB control board.

Vertiv provides the BCB box for use when the external battery installation is required. In this situation, The BCB box is fitted as close as possible to the battery and connected to the UPS. Refer to [Figure 9-1](#), [Table 9-5](#) and [Table 9-6](#) for description of the BCB box and its components.

The BCB box protects the battery against overdischarge and overcurrent, and also isolates the UPS and battery, thus reducing the risk at lowest for service personnel during the maintenance. The box inside has connection bars for connecting the power cables from the UPS and batteries.

NOTE: The signal cables from the UPS to the BCB control board must be routed in a separate cable trough and separated from battery power cables. The separate safety earth must be connected at the UPS side.

Table 9-5 Parameters of BCB box

Dimensions (H × W × D) (mm)	Weight (kg)	CB	10 times of CB
252×500×800	33	315A (3P)	3150A

NOTE: This weight excludes the packaging.

Figure 9-1 BCB box

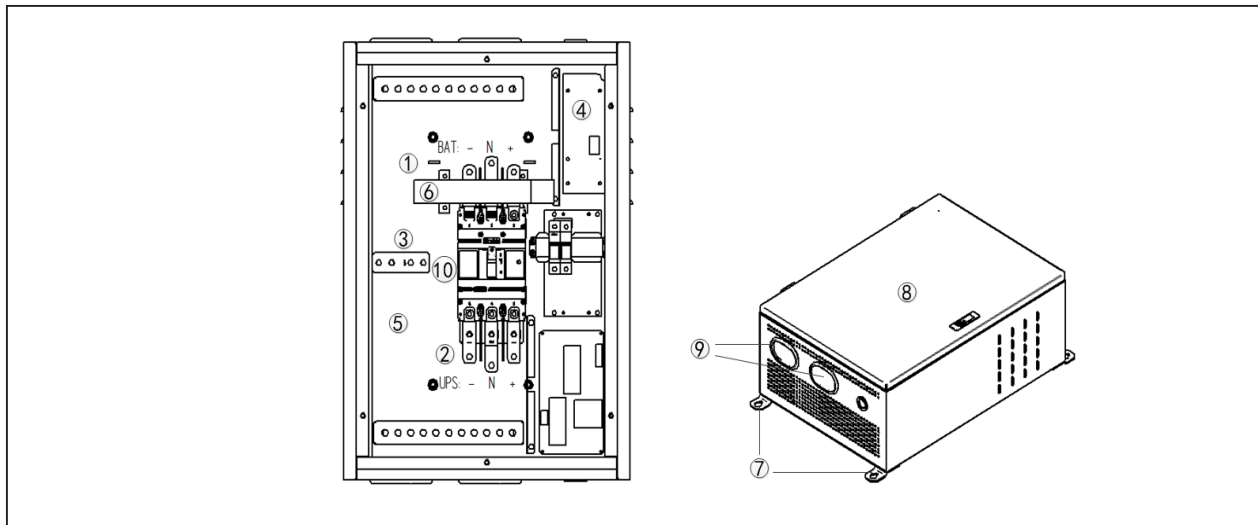

Table 9-6 Description of BCB box components

No.	Component
1	Battery connection terminal (BAT+/BAT N/BAT-)
2	UPS connection terminal (UPS+/UPS N/UPS-)
3	Grounding bar
4	Battery switch control board
5	Base plate
6	Current sensor to be installed when selecting battery ground fault kit
7	Wall-mounted installation hole
8	Protective door
9	Cabling hole for confirming the cable size and opening hole
10	Battery switch

9.5.2. Connection of BCB Box

Refer to [Figure 9-2](#) for the connection among battery, BCB and UPS.

Refer to [Table 9-7](#) for the communication cable's definition between the UPS and BCB.

Figure 9-2 Connection of BCB box

Table 9-7 Battery control port (X102)

BCB box port	Communication box port	Meaning	Signal state
DRV	BCB_DRIVE	Tripping control signal of BCB from the UPS	BCB tripping drive Normal: 0V Tripping: 12V
AUX	BCB_STATUS	Auxiliary contact of BCB (contact off means BCB off)	Normal: 0V, BCB closed; Abnormal: open, BCB open
GND	GND	Signal ground	GND to GND
BCB_ONLINE	BCB_ONLINE	BCB online state	To GND by default

NOTE: The cable of the J2 BCB port must be routed separately from the power cable. It uses the dual-insulated shielded cable (the CSA is generally 0.5mm² ~ 1mm² when the max. wiring distance is 30m), and the UPS side of the shielding coat must be connected to the enclosure reliably.

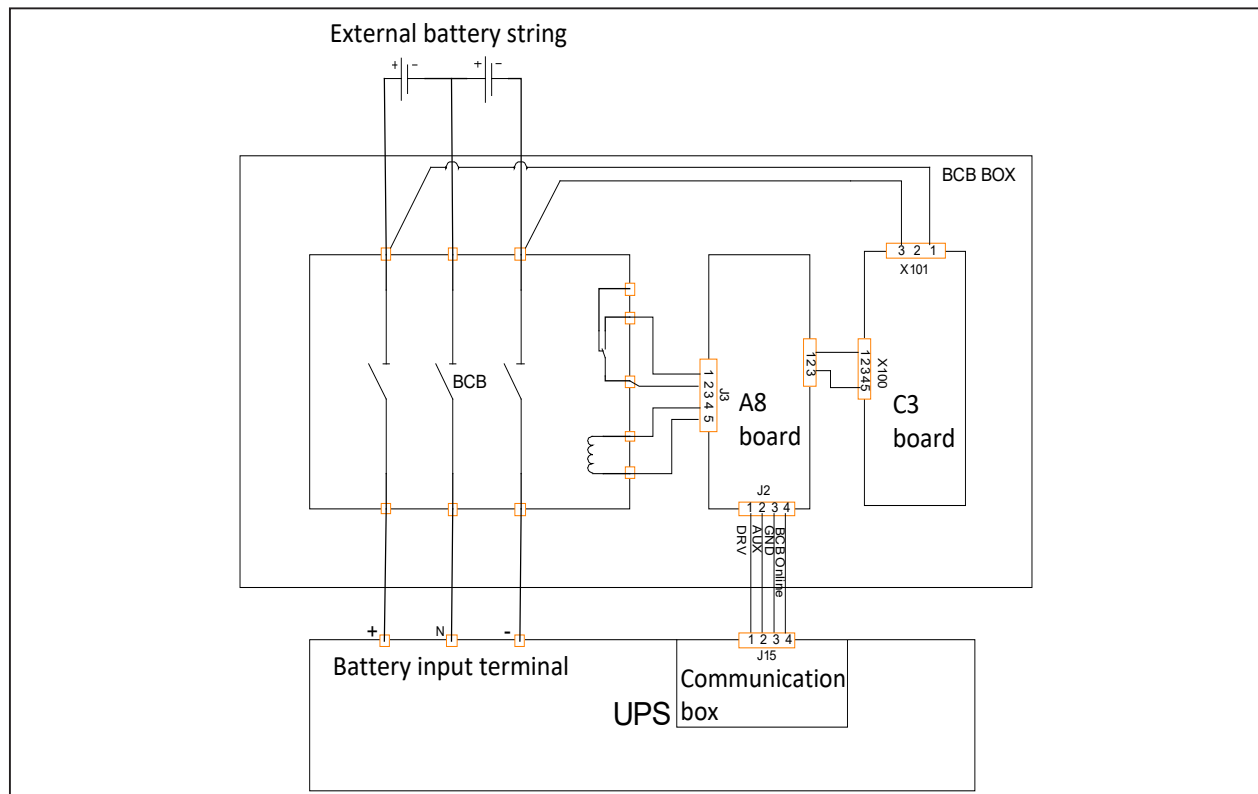

CAUTION: If the corresponding functions are not required, just do not connect corresponding terminals.

9.6 Battery Cabinet

The BCB cabinet contains batteries, BCB and a BCB control board.

Vertiv provides the BCB cabinet for battery backup use. Refer to [Figure 9-3](#), [Table 9-8](#) for description of the BCB cabinet and its data.

The BCB cabinet protects the battery against overdischarge and overcurrent, and also isolates the UPS and battery, thus reducing the risk at lowest for service personnel during the maintenance. The cabinet inside has connection bars for connecting the cables from the UPS.

NOTE: The signal cables from the UPS to the BCB control board must be routed in a separate cable trough and separated from battery power cables.

Table 9-8 Parameters of BCB cabinet

Dimensions (H × W × D) (mm)	Weight (without/with battery) (kg)	CB	10 times of CB
1600 × 600 × 850	130/560	180A (3P)	1800A

NOTE: This weight excludes the packaging.

Figure 9-3 Diagram of battery cabinet

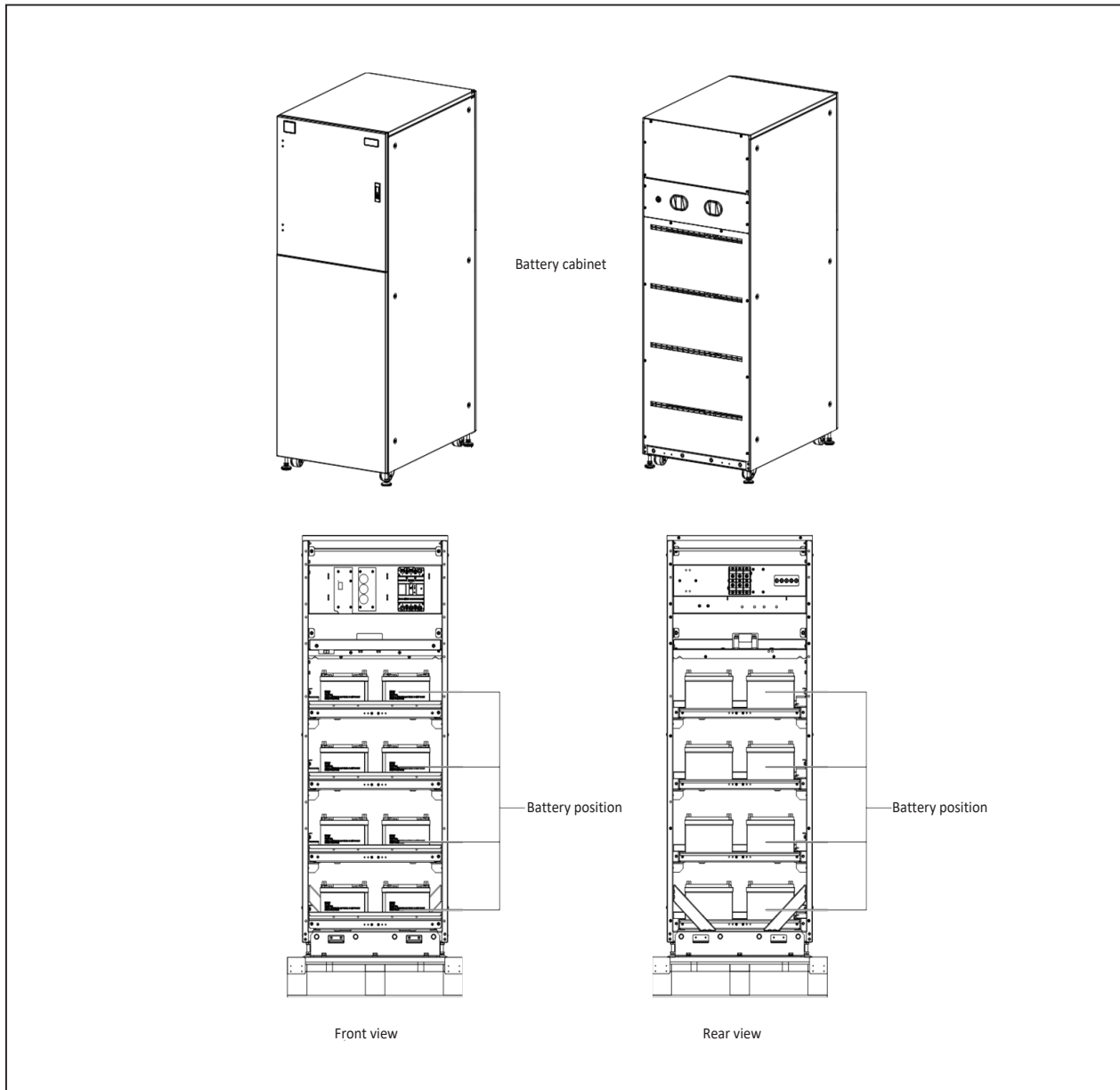

9.7 Output Transformer

This UPS includes an isolation transformer (see Figure 9-4 for its position) at the UPS output. This transformer is installed in the cabinet and provides electrical isolation between the UPS output and the load.

NOTE: When there is an inner transformer, the C-type breaker of 200A should be installed at upstream of the UPS.

Figure 9-4 Output transformer and its working principle

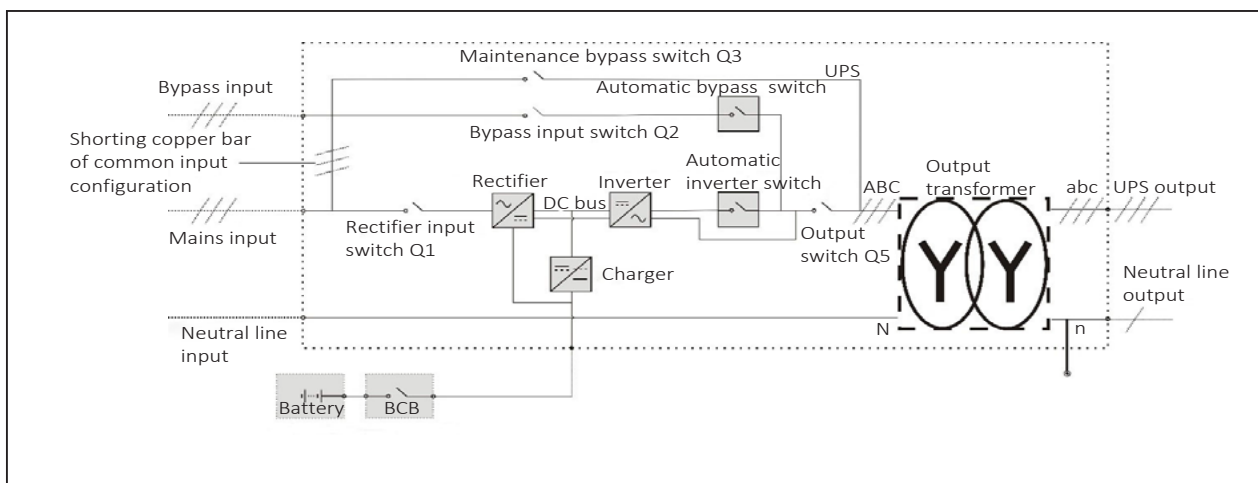
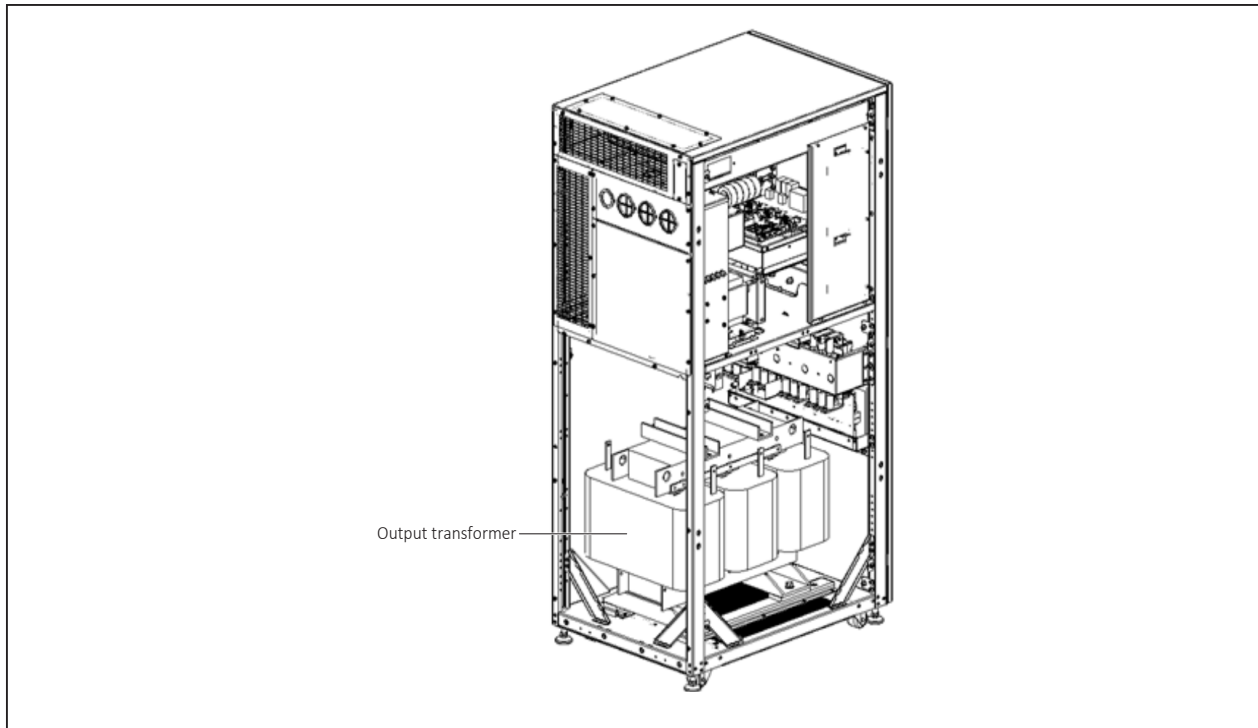

WARNING! 1. The optional output transformer is only suitable for 3-in 3-out mode.
2. When switching on the maintenance bypass switch, the output transformer is still live. During the transformer maintenance, you must shut down the UPS completely.

9.8 Top Fan

The top fan assembly provides the upward air outlet direction for UPS, as shown in [Figure 9-5](#). Assembled after factory delivery. Please refer to the quick installation instruction manual for the detailed assembly steps.

NOTE: Since the UPS uses rear cabling mode, it is still necessary to reserve a space of 200mm at rear of the UPS.

Figure 9-5 Top fan

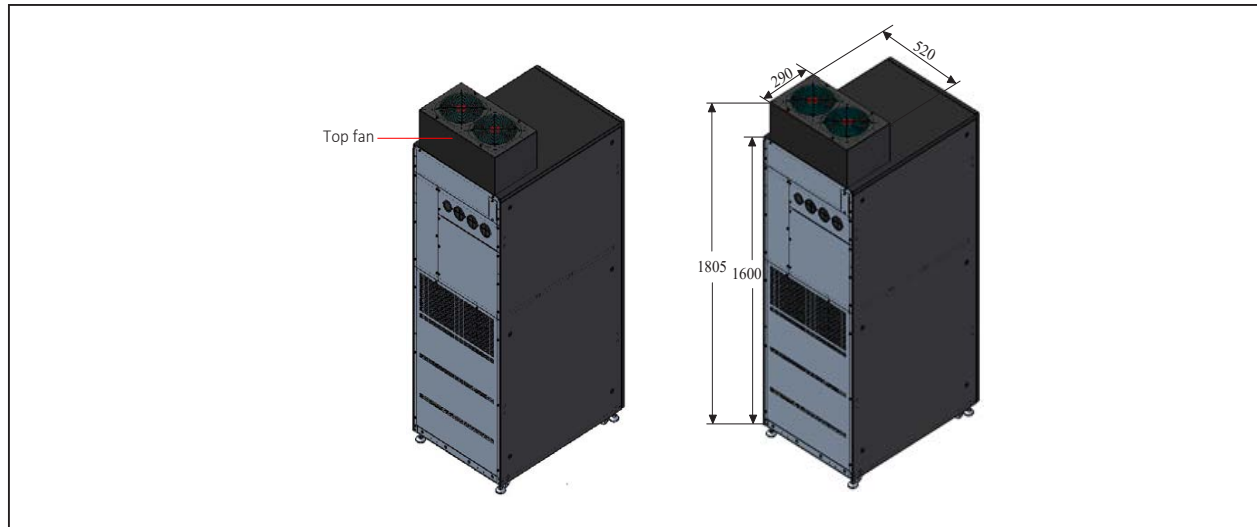

For more details, please refer to Liebert® EXS 80kVA UPS TOP FAN OPTION Quick Installation Guide in accessory.

9.9 IP31 Kit

The IP31 kit provides a higher level of protection for the UPS, as shown in [Figure 9-6](#). Assembled after factory delivery. Please refer to the quick installation instruction manual for the detailed assembly steps.

Figure 9-6 IP31 kit



NOTE: UPS power capacity will be de-rated by 10% by selecting IP 31 protection.

For more details, please refer to Liebert® EXS 80kVA UPS IP31 Quick Installation Guide in accessory.

9.10 C2 Electromagnetic Shielding Assembly

With the C2 electromagnetic shielding assembly fitted, this UPS is a Class C2 UPS product for residential environment. Installation restrictions or additional measures may be needed to prevent disturbances.

C2 electromagnetic shielding assembly for 80kVA UPS are installed in factory.

10 Specifications

This chapter lists the UPS specifications.

10.1 Conformance and Standards

Table 10-1 Conformance and standards

Item	Standard
Conduction emission	IEC/EN62040-2 Standard product meets Class C3, the product with C2 option installed meets Class C2
EFT	IEC/EN62040-2: AC port withstand pulse group impact of 4kV/5kHz
Harmonic current	IEC/EN62040-2, 16 A < I ≤ 75 A
Input voltage flash	IEC/EN62040-2, 16 A < I ≤ 75 A
Electrostatic discharge immunity	IEC/EN62040-2: Level 3
Radiation immunity	IEC/EN62040-2: Level 3
PFMF	IEC/EN62040-2: Level 4
Surge protection	Meets IEC/EN62040-2: live line to earth withstand level 4 (4kV); withstand level 3 between live lines (2kV)
Safety	IEC/EN62040-1
SPD test	Meets ANSI C62.41: live line to earth withstand 6kV/3Ka Meets YD/T944: live line to earth withstand 5kA

10.2 Environmental Characteristics

Table 10-2 Environmental characteristics

Item	Unit	Meaning
Noise within 1m (in the front)	dB (A)	< 60
Altitude	m	≤1 500, non-derating; ≥1500 (derate power by 1 % per 100 m); up to 3000
Relative humidity	%RH	5 ~ 95%, non condensing
Operating temperature	°C	0 to 40 °C (Note: Battery life is halved for every 10 °C increased when above 20 °C)
Storage and transport ation temperature for UPS	°C	-40 °C ~ +70 °C
Over-voltage level		Overvoltage level 2
Pollution level		Pollution level 2

10.3 Mechanical Characteristics

Table 10-3 Mechanical characteristics

Item	Unit	Rated power (kVA)
		80 kVA
Dimensions (W × D × H)	mm	600 × 850 × 1600; with top fan kit (600 × 850 × 1805)
Net weight	kg	230; with transformer (580)
Gross weight	kg	260; with transformer (610)
Color		Black (ZP7021)
Protection degree		IP20 (front door open or closed)

10.4 Electrical Characteristics (Input Rectifier)

Table 10-4 Rectifier AC input (mains)

Item	Unit	Rated power (kVA)
		80kVA
Rated AC input voltage	Vac	380 / 400 / 415 (Line voltage)
Input voltage range	Vac	176 to 275, at full load; 132 to 176, derated
Frequency	Hz	50/60 (range: 40 to 70)
Power factor	kW/kVA, full load (half load)	0.99 (0.98)

10.5 Electrical Characteristics (Battery)

Table 10-5 Battery

Item	Unit	Rated power (kVA)
		80kVA
Type		VRLA battery
Battery cell	Block	32 / 34 / 36 / 38 / 40-block, at full load; 26 / 28 / 30-block, derated
Max. charge current	A	25

10.6 Electrical Characteristics (Inverter Output)

Table 10-6 Battery

Item	Unit	Rated power (kVA)
		80kVA
Rated AC voltage	Vac	380 / 400 / 415 (Line voltage)
Frequency	Hz	50 / 60
Overload	%	For linear load requirement: < 105 %, continues; 105 to 110 % of rated load, 60 mins; 110 to 125 % of rated load, 10 mins; 125 to 150 % of rated load, 1 min; > 150 %, 200 ms
Rated power factor		1
Crest factor		3:1
Voltage harmonic distortion	%	< 1.5 % (linear load); < 4.5 % (non-linear load)
Dynamic response recovery time	ms	40
Frequency synchronization range	Hz	Rated frequency ± 3 Hz. Configurable range: $\pm 0.5 / \pm 1 / \pm 2 / \pm 3 / \pm 10$ %
Frequency track rate	Hz/s	Configurable range: 0.1 to 3 Hz/s (single module), 0.6 Hz/s (several modules)
Double conversion efficiency (without transformer)	%	Up to 96.2 %

10.7 Electrical Characteristics (Bypass Input)

Table 10-7 Bypass input

Item	Unit	Rated power (kVA)
		80kVA
Rated AC voltage	Vac	380 / 400 / 415 (Line voltage)
Overload	%	< 110%, continues; 110 to 125 % of rated load, 10 mins; 125 to 150 % of rated load, 1 min; 150, 200 ms
Frequency	Hz	For linear load requirement: < 105 %, continues; 105 to 110 % of rated load, 60 mins; 110 to 125 % of rated load, 10 mins; 125 to 150 % of rated load, 1 min; > 150 %, 200 ms
Bypass voltage tolerance	%Vac	Settable: +10 %, +15 % or +20 %; default: +15 % Settable: -10 %, -20 %, -30 % or -40 %; default: -20 %

This page is intentionally left blank.

Appendix I LCD Parameters Setting

Menu	Item	Setting range	Default setting
Monitor	Language	Chinese, English, Deutsch, Italiano, Français, Čeština, Nederlands, Português, Svenska, Türkçe, Español, Русский, Polski	English
	Date format	YY/MM/DD, MM/DD/YY, DD/MM/YY	MM/DD/YY
	Date	MM-DD-YY	01-01-2018
	Time	HH: MM: SS	00: 00: 00
	Audible alarm	Disable, Enable	Disable
	Serial port 1 baudrate	1200bps, 2400bps, 4800bps, 9600bps, 19200bps	9600bps
	Serial port 2 baudrate	1200bps, 2400bps, 4800bps, 9600bps, 19200bps	9600bps
	UPS address	Ddd ('d' is a decimal number)	001
	Card slot protocol	YDN23, Velocity	YDN23
Change settings password	The password is numeric only and can be set from 0 to 9. The password length is 6	111111	

Menu	Item	Setting range	Default setting
System	System configuration	Single, Parallel	Parallel
	LBS configuration	None, LBS slave, LBS master	None
	System operation mode	Normal, Intelligent parallel, Intelligent parallel demo, ECO, Frequency converter(have battery), Frequency converter(no battery), Power conditioner, Self aging, Testing Note: 1. Need EPO to set or exit Self aging mode. 2. Not support self-aging mode when inner output transformer seeting active. Can cancel inner output transformer setting to do self-aging operation	Normal
	Bypass Inhibit for Generator Mode	Disable, Enable	Disable
	Power walk in time interval	1~5s	5s
	Output auto-recovery after EOD	Disable, Enable	Enable
	Output auto-recovery delay after EOD	1~1440min	10min
	BCB shut trip at EOD	Enable, Disable	Enable
HRG(IT) system configuration	HRG system, Other system	Other system	
Auto-restart for power lost shutdown	Disable, Enable Note: This item is only available for Frequency Converter Mode and Power Conditioner Mode	Enable	

Menu	Item	Setting range	Default setting
Output	System Voltage Level(L-L)	208V,220V,380V,400V,415V Note: 1.Setting range may vary from different model name. 2.Please don't set this parameter when UPS at inverter power mode or ECO inverter standby mode.	208V Note: Default settings may be different for different model name.
	Output Frequency Level	50Hz, 60Hz Note: Please don't set this parameter when UPS at inverter power mode or ECO inverter standby mode	50Hz
	Output Voltage Adjustment	208V: 114~126V 220V: 120~133V 380V: 209~231V 400V: 218~242V 415V: 228~252V Note: related to system voltage level.-5% ~ +5% of nominal output voltage	120V/127V /220V/230V/240V Note: related to system voltage level. Equal to nominal output voltage
	Output Transfer Interrupt Time	<20ms, 40ms, 60ms, 80ms, 100ms	<20ms
	Excessive Auto Retransfers	1~10	5
	Bypass Unable to Trace Event Audible/Flashing	Disable, Enable	Disable
	Byp. Frequency Sync. Range	±10%, ±0.5Hz, ±1.0Hz, ±2.0Hz, ±3.0Hz Note: Please change this item under bypass mode or EPO state	±10%
	Byp. Volt. Protection Upper Limit	+15%, +10%, +20%	+15%
	Byp. Volt. Protection Lower Limit	-20%, -10%, -15%, -30%, -40%	-20%
	Byp. Volt. Sync. Range Upper Limit In ECO Mode	+5%, +10%, +15%	+5%
Byp. Volt. Sync. Range Lower Limit In ECO Mode	-5%, -10%, -15%	-5%	

Menu	Item	Setting range	Default setting
Battery	Shared battery	Enable , Disable	Disable
	Battery strings	1~4	1
	Cells per string	80~360 Note: Setting range may vary for different system voltage level and different battery type	120 Note: Default value may be different for different system voltage level, different battery type and different model name.
	Ah/W per block	7~3000 Ah/W Note: 1.The unit of battery capability is AH for VRLA, wet, Ni-Cd and Li-ion battery, while Watt for high discharge rate VRLA. 2. The product of Nominal Battery Ah/W Per Block and Battery String Count is limited to 6553.5	7Ah/W
	Auto equalize charge	Enable , Disable	Disable
	Temp. compensation	Enable , Disable	Disable
	Automatic test	Enable , Disable	Disable
	Automatic test period	30~360 Day	60 Day
	Period test time	HH:MM	00:00
	Period test weekday	Monday~Sunday	Sunday
	Low prewarning time	2~60 Min	5 Min
	Max. discharge time	1~72 Hour	24 Hour
Battery	UPS ID No.	1~4	1
	Requisite UPS Units	1~4	1
	Redundant UPS Units	0~3	0
	Sleeping Cycle Of IP Mode	1~1000 Day	30 Day

Menu	Item	Setting range	Default setting
Dry contact	Battery Capacity Setting for Load Shed Signal 1	0~100%	0
	Battery Backup Time Setting for Load Shed Signal 1	0~3600 Sec	0 Sec
	Battery Capacity Setting for Load Shed Signal 2	0~100%	0
	Battery Backup Time Setting for Load Shed Signal 2	0~3600 Sec	0 Sec
	General Purpose Dry Contact J14-5/7(O)	N/A, Summary alarm, On battery, Low Battery Alarm, UPS Fault, On Bypass, On Inverter, Remote EPO Status, Input Mains Failure, Maint. Bypass Switch Closed, Load Shed Signal 1, Load Shed Signal 2, Maint. Bypass Switch Interlock	N/A
	General Purpose Dry Contact J14-1/3(O)	N/A, Summary alarm, On battery, Low Battery Alarm, UPS Fault, On Bypass, On Inverter, Remote EPO Status, Input Mains Failure, Maint. Bypass Switch Closed, Load Shed Signal 1, Load Shed Signal 2, Maint. Bypass Switch Interlock	N/A
	General Purpose Dry Contact J13-13(I)	N/A, onGen, Inhibit trans. to inverter, Ext_MIB, Ext MBB status, MOB, Battery GND Fault, Charger Off, Suspend ECO mode, Start Battery Maint. Test, Stop Battery Maint. Test, Alarm Reset	onGen
	General Purpose Dry Contact J13-2(I)	N/A, onGen, Inhibit trans. to inverter, Ext_MIB, Ext MBB status, MOB, Battery GND Fault, Charger Off, Suspend ECO mode, Start Battery Maint. Test, Stop Battery Maint. Test, Alarm Reset	Inhibit trans. to inverter
	General Purpose Dry Contact J13-1(I)	N/A, onGen, Inhibit trans. to inverter, Ext_MIB, Ext MBB status, MOB, Battery GND Fault, Charger Off, Suspend ECO mode, Start Battery Maint. Test, Stop Battery Maint. Test, Alarm Reset	Ext_MIB
	General Purpose Dry Contact J13-9(I)	N/A, onGen, Inhibit trans. to inverter, Ext_MIB, Ext MBB status, MOB, Battery GND Fault, Charger Off, Suspend ECO mode, Start Battery Maint. Test, Stop Battery Maint. Test, Alarm Reset	Ext MBB status
	General Purpose Dry Contact J13-5(I)	N/A, onGen, Inhibit trans. to inverter, Ext_MIB, Ext MBB status, MOB, Battery GND Fault, Charger Off, Suspend ECO mode, Start Battery Maint. Test, Stop Battery Maint. Test, Alarm Reset	MOB

Menu	Item	Setting range	Default setting
Control	Turn on/off/to bypass	/	/
	Mute/Unmute audible alarm	/	/
	Battery maintenance test	/	/
	Stop battery test	/	/
	Clear faults	/	/
Maintain	Battery capacity test	/	/
	Start equalize charge	/	/
	Stop equalize charge	/	/
	Battery reset	/	/
	Start maintenance guide	/	/
	Exit maintenance guide		

Appendix II Glossary

AC	Alternating current
CB	Circuit breaker
CSA	Cross sectional area
DC	Direct current
DIP	Dual in-line package
DSP	Digital signal processor
EMC	Electromagnetic compatibility
EMI	Electromagnetic interference
EOD	End-of-discharge
EPO	Emergency power off
I/O	Input/output
LBS	Load bus synchronizer
LCD	Liquid crystal display
LED	Light-emitting diode
MCB	Miniature circuit breaker
NMS	Network management system
PE	Protective earth
RCCB	Residual current circuit breaker
RCD	Residual current detector
REPO	Remote emergency power off
RFI	Radio frequency interference
SCR	Silicon-controlled rectifier
SNMP	Simple network monitoring protocol
STS	Static transfer switch
UPS	Uninterruptible power system
VRLA	Valve-regulated lead-acid

Appendix III Hazardous Substances and Content

Parts	Hazardous substances					
	Plumbum	Hydrar-gyru	Cadmium	Chrome6+	PBB	PBDE
	(Pb)	(Hg)	(Cd)	(Cr (VI))	(PBB)	(PBDE)
PCBA	○	○	○	○	○	○
AC capacitor	○	○	○	○	○	○
DC capacitor	○	○	○	○	○	○
Fan	○	○	○	○	○	○
Cables	○	○	○	○	○	○
LCD	○	×	○	○	○	○
Sensors	○	○	○	○	○	○
Large-medium power magnetic components	○	○	○	○	○	○
Circuit breaker	○	○	○	○	○	○
Semiconductors	○	○	○	○	○	○
Battery (when applicable)	×	○	○	○	○	○
Insulation monitoring device (when applicable)	N/A	N/A	N/A	N/A	N/A	N/A
<p>This table is made following the regulation of SJ/T 11364.</p> <p>○ : Means the content of the hazardous substances in all the average quality materials of the parts is within the limits specified in GB/T 26572</p> <p>× : Means the content of the hazardous substances in at least one of the average quality materials of the parts is outside the limits specified in GB/T 26572.</p>						
<p>About battery: Generally follow the environmental protection use period of the battery, otherwise five years.</p>						
<p>Applicable scope: Liebert® EXS 80kVA UPS</p>						



© 2020 Vertiv Group Corp. All rights reserved. Vertiv™ and the Vertiv logo are trademarks or registered trademarks of Vertiv Group Corp. All other names and logos referred to are trade names, trademarks or registered trademarks of their respective owners. While every precaution has been taken to ensure accuracy and completeness here, Vertiv Group Corp. assumes no responsibility, and disclaims all liability, for damages resulting from use of this information or for any errors or omissions. Specifications, rebates and other promotional offers are subject to change at Vertiv's sole discretion upon notice.

BOM: 31014052 V1.1