



LIEBERT® NXC™ 30kVA & 40kVA UPS

Reliable & Scalable power system designed
for Small and Mid-size Enterprises

Installer/User Guide

Liebert NXC 30kVA And 40kVA UPS

User Manual

Version	V1.9
Revision date	November 15, 2018
BOM	31012712

Vertiv provides customers with technical support. Users may contact the nearest Vertiv local sales office or service center.

2012 Copyright, 2017 by Vertiv Tech Co., Ltd.

All rights reserved. The contents in this document are subject to change without notice.

Special Declaration

Personnel Safety

1. This product must be installed and commissioned by professional engineers of the manufacturer or its authorized agent. Failure to observe this could result in product malfunction or personnel safety risk.
2. Take the time to read this product manual and the safety precaution thoroughly before installing and commissioning this product. Failure to observe this could result in product malfunction or personnel safety risk.
3. This product cannot be used as power supply of life support equipment.
4. Never dispose of the internal or external battery of this product in a fire, as it may explode and jeopardize personnel safety when exposed to flame.

Product Safety

1. If this product will be stored or remain de-energized for a long period, it must be placed in a dry and clean environment within specified temperature range.
2. This product should be used in an appropriate operating environment. For details, refer to the section on the environmental requirement in this manual.
3. It is prohibited to use this product in places:
 - Where the temperature and relative humidity are outside the specifications
 - Subject to vibrations or shocks
 - Where conductive dusts, corrosive gases, salts, or flammable gases are present
 - Near heat sources or strong electromagnetic interferences

Disclaimer

Vertiv disclaims any and all responsibility or liability for the defection or malfunction caused by:

- Application range or operating environment outside the specifications
- Unauthorized modification, improper installation or operation
- Force majeure
- Other actions not in compliance with the instructions in this manual

Safety Precaution

Always observe the following safety symbols!



Used to alert the user to the risk of death or severe injury should the unit be used improperly.



Used to alert the user to the risk of injury or equipment damage should the unit be used improperly.



Used to advise the user to carefully read and observe this unit though it may not cause damage.

This manual contains information concerning the installation and operation of single UPS module and parallel system of the Vertiv NXC 30kVA and 40kVA UPS.

Read this manual thoroughly before installing, using and servicing the UPS.

The UPS must be commissioned and serviced by trained engineers approved and qualified by the manufacturer or its agent. Failure to observe this could result in personnel safety risk, equipment malfunction and invalidation of warranty.



This UPS is a product for commercial and industrial application in the second environment. Installation restrictions or additional measures may be needed to prevent disturbances.

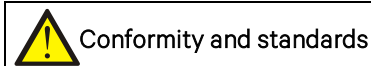

This product complies with CE 2006/95/EC (low voltage safety) and 2004/108/EC (EMC), EMC standards of Australia and New Zealand (C-Tick), and the following UPS product standards:

- * IEC62040-1 General safety requirements for UPS
- * IEC62040-2-EMC
- * IEC62040-3 Performance requirements and test methods

For details, refer to *Chapter 11 Specifications*.

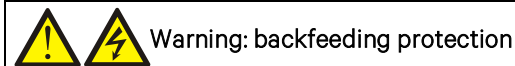

Continued compliance requires installation in accordance with these instructions and the use of manufacturer approved accessories only.



This UPS is fitted with a dry contact closure signal for use with an external automatic disconnect device (supplied by others) to protect against backfeeding voltage into the incoming terminal through the rectifier or bypass static switch circuit. A label must be added at the external incoming bypass supply disconnect device to warn service personnel that the circuit is connected to a UPS. The text of the label has the following meaning: Risk of voltage backfeed! Isolate the UPS, then check for hazardous voltage between all terminals including the protective earth before working on this circuit.

  **Warning**

The selection of the prestage distribution protection equipment of the UPS system must comply with the local electric regulations.

  **Warning: high earth leakage current**



Earth connection is critical before connecting the input supply (including both mains supply and battery). This equipment is installed with EMC filter.
Earth leakage current is 0 ~ 1000mA.
Transient and steady state earth leakage currents, which may occur when the equipment is started, should be taken into account in the selection of instantaneous RCCBs or RCD devices.
RCCB which is sensitive to unidirectional DC pulse (class A) and insensitive to transient state current pulse must be selected.
Note also that the earth leakage currents of the load will be carried by the RCCBs or RCDs.
The equipment must be earthed in accordance with the local electrical authority codes of practices.

  **Warning**

The selection of the prestage distribution protection equipment of the UPS system must comply with the local electric regulations.

  **General safety precautions**



Like other types of large power equipment, the UPS and battery circuit breaker box/battery cabinet have high voltage inside. Because the components with high voltage can be accessed only when the front door (which is locked) is opened, the risk of contacting high voltage has been minimized. This equipment meets the IP20 standard, and other safety shields are provided inside the equipment.
There will not be any danger when operating this equipment according to the general instructions and the steps recommended in this manual.

  **User serviceable components**

All the equipment maintenance and servicing procedures involving internal access need tools and should be carried out only by trained personnel. The components that can only be accessed by opening the protective cover with tools/special key cannot be maintained by the user.

  **Multiple power inputs**

This UPS system receives power from more than one source. Disconnection of all AC source and the DC source is required before servicing.
This UPS has several circuits that are energized with high AC as well as DC voltages. Check for voltage with both AC and DC voltmeters before working within the UPS.

  **Battery voltage: 320Vdc ~ 540Vdc**

All the battery physical maintenance and servicing procedures need special tools and should be carried out only by trained personnel. Take special care when working with the batteries associated with this UPS. When the batteries are connected together, the battery terminal voltage exceeds 320Vdc and is potentially lethal. Battery manufacturers supply details of the necessary precautions to be observed in working on or in the vicinity of battery strings. These precautions should be followed implicitly at all times. Particular attention should be paid to the recommendations concerning local environmental conditions and the provision of protective clothing, first aid and fire-fighting facilities.



When the internal fuse of the UPS is damaged, it must be replaced with fuse of the same electric parameters by professionals.



Beside the communication board is a static sensitive area, ESD-proof action is critical before contacting with this area.



When selecting the UPS system pre-stage distribution protection equipment, ensure that it complies with the local electric regulations.
The specified upstream breakers are required to obtain the conditional short-circuit current rating, Icc at 10kA symmetrical rms. The specified upstream breakers should comply with an IEC 60947 series standard.

The Manual Describes The Following Equipment

Product	Model
Liebert NXC 30kVA	NXC 0030kJ1AFN02000
Liebert NXC 40kVA	NXC 0040kJ1AFN02000

Revision Information

V1.0 (December 25, 2012)

Initial release.

V1.1 (April 24, 2013)

Optimize the content of Sections 3.2.7 and 3.2.9.

V1.2 (December 23, 2013)

Add '3-in 1-out' mode and its corresponding parameter; add Sections 8.2.10 ~ 8.2.13.

V1.3 (June 4, 2014)

Change '500mm' to '200mm' in Section 2.6.2; optimize dimensions of bottom view in Figure 2-7; enrich the content in Section 8.2.2; add Hazardous Substances Or Elements Announcement in Appendix 3.

V1.4 (July 29, 2014)

Modify all the torque values in Section 8.2.2 and Section 8.2.11.

V1.5 (October 10, 2014)

Add the information of removing fixing bars in Figure 2-6.

V1.6 (December 24, 2015)

Add a Warning in Safety Precaution; update Note in Section 3.1.4 and update Table 3-3.

V1.7 (March 10, 2017)

Update Appendix 3.

V1.8 (November 15, 2017)

Update related information about Vertiv.

V1.9 (November 15, 2017)

Update Figure 6-4 and Table 6-5

Contents

Chapter 1 Overview.....	1
1.1 Features.....	1
1.2 Design Concept.....	1
1.2.1 System Design.....	1
1.2.2 Bypass.....	2
1.2.3 System Control Principle.....	3
1.2.4 UPS Power Supply Switch Configuration.....	4
1.2.5 Battery Circuit Breaker (BCB).....	5
1.3 Parallel System.....	5
1.3.1 Parallel System Features.....	5
1.3.2 Parallel System Requirements.....	5
1.4 Operation Modes.....	5
1.5 Battery Management.....	9
1.5.1 Normal Function.....	9
1.5.2 Advanced Function.....	9
1.5.3 Battery Temperature Compensation.....	10
1.6 Battery Protection.....	10
Chapter 2 Mechanical Installation.....	12
2.1 Precautions.....	12
2.2 Transportation.....	12
2.3 Unpacking.....	13
2.4 Initial Inspection.....	15
2.5 Environmental Requirement.....	15
2.5.1 UPS Location Selection.....	15
2.5.2 Battery Location Selection.....	16
2.5.3 Storage.....	16
2.6 Mechanical Requirement.....	16
2.6.1 Moving Cabinet.....	16
2.6.2 Clearance.....	17
2.6.3 Cable Access Mode.....	17
2.6.4 Final Positioning And Fixing.....	17
2.7 Installation Drawings.....	19
Chapter 3 Electrical Installation.....	20
3.1 Wiring Of Power Cable.....	20
3.1.1 System Configuration.....	20

3.1.2 Maximum Steady State AC And DC Currents	20
3.1.3 Recommended CSA Of UPS Cable.....	21
3.1.4 Selection Of UPS I/O Switch	21
3.1.5 Distance Between The UPS Connection Point And The Floor	22
3.1.6 Notes.....	22
3.1.7 Power Cable Connecting Terminal	22
3.1.8 Protection Ground.....	23
3.1.9 External Protective Device.....	23
3.1.10 Power Cable Connection Steps	24
3.2 Wiring Of Signal Cable	30
3.2.1 Overview.....	30
3.2.2 Input Dry Contact Port.....	30
3.2.3 BCB Port.....	31
3.2.4 Backfeed Protection Dry Contact Port	32
3.2.5 Remote EPO Input Port	32
3.2.6 RS232 Communication Port.....	33
3.2.7 USB Communication Port.....	33
3.2.8 Parallel And LBS Communication Ports	34
3.2.9 RS485 Communication Port.....	34
3.2.10 Intellislot Port	34
3.2.11 Signal Cable Connection Steps.....	34
Chapter 4 Operator Control And Display Panel.....	36
4.1 Introduction.....	36
4.1.1 LED Indicators	36
4.1.2 Audible Alarm (Buzzer)	37
4.1.3 Control Keys	37
4.1.4 LCD And Menu Keys.....	37
4.2 LCD Screen Type.....	39
4.2.1 Start Screen	39
4.2.2 Primary Screen.....	39
4.2.3 Default Screen.....	40
4.3 Detailed Description Of Menu Items	40
4.4 Prompt Window	43
4.5 Alarm List	43
Chapter 5 UPS Operation Introduction	47
5.1 Brief Introduction	47
5.1.1 Precautions	47
5.1.2 Power Switch.....	47
5.2 UPS Startup Procedures	48

5.2.1 Startup Procedures In Normal Mode.....	48
5.2.2 Startup Procedures In ECO Mode	49
5.2.3 Startup Procedures In Battery Mode (Battery Cold Start)	49
5.3 Procedures For Transfer Between Operation Modes	50
5.3.1 Transfer From Normal Mode To Battery Mode.....	50
5.3.2 Transfer From Normal Mode To Bypass Mode.....	50
5.3.3 Transfer From Bypass Mode To Normal Mode.....	50
5.3.4 Transfer From Normal Mode To Maintenance Mode.....	50
5.3.5 Transfer From Maintenance Mode To Normal Mode.....	52
5.4 Battery Test Procedures.....	52
5.5 UPS Self-test Procedures.....	53
5.6 UPS Shutdown Procedures	53
5.6.1 Procedures For Completely Powering Down UPS	53
5.6.2 Procedures For Completely Powering Down UPS While Maintaining Power To Load.....	54
5.7 EPO Procedures	54
5.8 UPS Reset Procedures After EPO	54
5.9 Automatic Restart.....	55
5.10 Selecting Language.....	55
5.11 Changing Current Date And Time	56
5.12 Control Password	56
Chapter 6 Battery	57
6.1 Introduction.....	57
6.2 Safety	57
6.3 UPS Battery	59
6.4 Precautions For Installation Design	60
6.5 Battery Installation Environment And Number Of Batteries	60
6.5.1 Installation Environment.....	60
6.5.2 Number Of Batteries.....	61
6.6 Battery Protection.....	61
6.7 Battery Installation And Connection	61
6.7.1 Battery Installation.....	61
6.7.2 Battery Connection.....	62
6.8 Design Of Battery Room	65
6.9 BCB Box (Optional).....	65
6.10 BCB Reference Current And Connection.....	68
6.11 Battery Maintenance.....	68
6.12 Disposal Of Used Battery	69
Chapter 7 Parallel System And LBS System.....	70
7.1 General	70

7.2 System Installation Procedures.....	70
7.2.1 Preliminary Checks.....	70
7.2.2 Cabinet Installation.....	70
7.2.3 Power Cable.....	71
7.2.4 Parallel Cable.....	71
7.2.5 Remote EPO.....	72
7.3 ion Procedures For Parallel System.....	72
7.3.1 Startup Procedures In Normal Mode.....	73
7.3.2 Maintenance Bypass Procedures.....	73
7.3.3 Procedures For Isolating One UPS Module From Parallel System.....	75
7.3.4 Procedures For Inserting One Isolated UPS Module In Parallel System.....	75
7.3.5 Procedures For Completely Powering Down UPS.....	76
7.3.6 Procedures For Complete UPS Shutdown While Maintaining Power To Load.....	76
7.4 LBS System.....	76
7.4.1 Cabinet Installation.....	76
7.4.2 External Protective Device.....	78
7.4.3 Power Cable.....	78
7.4.4 LBS Cable.....	78
Chapter 8 Options.....	79
8.1 Option List.....	79
8.2 Option Introduction.....	80
8.2.1 Bypass Load Sharing Inductor Kit.....	80
8.2.2 Internal Battery Kit.....	83
8.2.3 Battery Temperature Compensation Kit.....	89
8.2.4 Seismic Anchor Kit.....	91
8.2.5 Air Filter.....	93
8.2.6 IS-WEBL Card.....	93
8.2.7 IS-Relay Card.....	94
8.2.8 IS-485L Card.....	96
8.2.9 BCB Box.....	96
8.2.10 C2 Electromagnetic Shielding Assembly.....	96
8.2.11 Output Transformer.....	96
8.2.12 Lightning Proof Plate.....	104
8.2.13 3-in 1-out Copper Bar Kit.....	105
Chapter 9 Communication.....	109
9.1 SNMP Protocol Communication.....	109
9.2 Modbus Protocol Communication.....	109
9.3 Dry Contact Communication.....	109
9.3.1 Communication Through IS-Relay Card.....	110

9.3.2 Communication Through Dry Contact Port.....	110
Chapter 10 Service And Maintenance.....	111
10.1 Safety	111
10.2 Key Components And Service Life Of UPS	111
10.2.1 Life Parameters And The Proposed Replacement Time Of Key Components.....	111
10.2.2 Replacement Of Air Filter.....	111
10.2.3 Replacement Of Fuse.....	112
10.3 Maintenance Of UPS And Options.....	112
Chapter 11 Specifications	114
11.1 Conformance And Standards.....	114
11.2 Environmental Characteristics	114
11.3 Mechanical Characteristics	114
11.4 Electrical Characteristics (Input Rectifier)	115
11.5 Electrical Characteristics (Intermediate DC Circuit)	115
11.6 Electrical Characteristics (Inverter Output).....	117
11.7 Electrical Characteristics (Bypass Input)	117
11.8 Efficiency And Loss.....	118
Appendix 1 Disposal Of Old Appliances	119
Appendix 2 Glossary.....	120
Appendix 3 Hazardous Substances And Content.....	121

Chapter 1 Overview

This chapter briefly introduces the features, design concept, parallel system, operation mode, battery management and battery protection of the Liebert NXC 30kVA and 40kVA UPS (UPS for short).

1.1 Features

The UPS is connected between a critical load (e.g. a computer) and mains power to provide high quality power for the loads. The UPS has the following advantages:

- Increase power quality

The UPS protects its output against the input power change through the internal voltage and frequency controller.

- Improve noise rejection

Due to the application of AC-DC-AC conversion mode, the noise in the input power is effectively filtered, and the load gets clean power supply.

- Provide mains failure protection

If the input power fails, the UPS will work in battery mode, and the power supply to the loads will not be interrupted.

- Compatible with two output modes

3-in 3-out (factory default) and 3-in 1-out (by an option of 3-in 1-out copper bar kit). Only authorized personnel shall change the cabling method and then set corresponding parameters through Vertiv setting software.

1.2 Design Concept

1.2.1 System Design

This section introduces the working principle of the single UPS module. The UPS adopts AC-DC-AC converter (as shown in Figure 1-1). The first stage conversion (AC-DC) adopts three-phase high frequency rectifier to convert the three-phase input voltage into stable DC bus voltage.

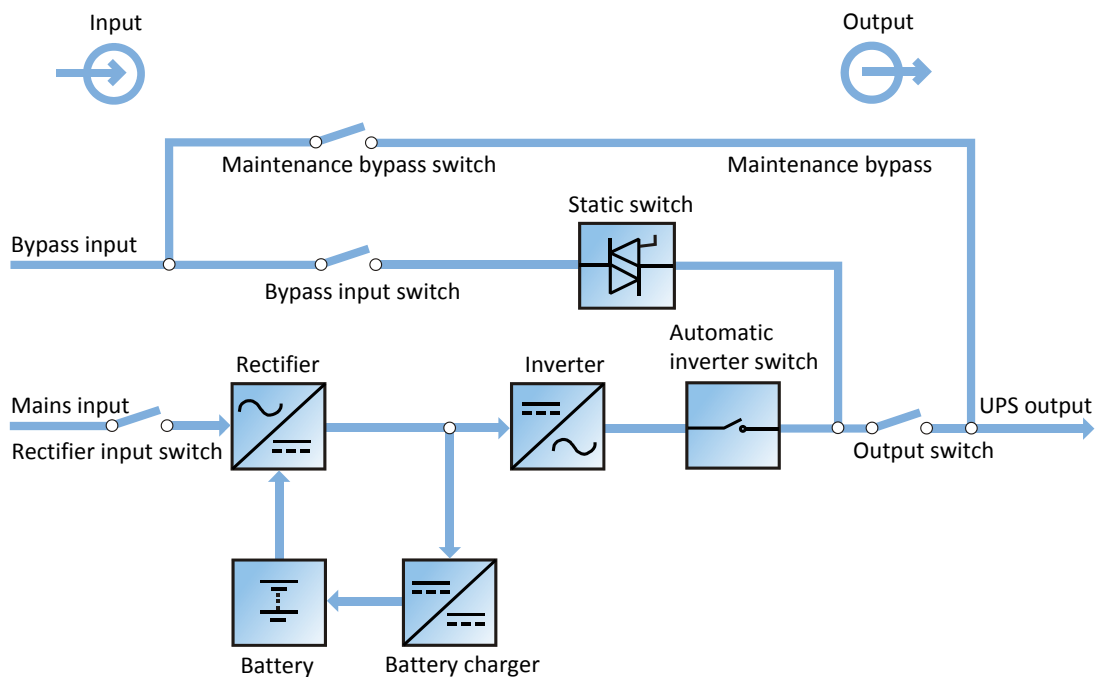

Figure 1-1 Block diagram for working principle of single UPS module

The UPS has its own battery charger and adopts advanced temperature compensation technology to effectively prolong the battery service life. The inverter mainly adopts large power IGBT, and adopts advanced SVPWM technology for control, to invert the DC bus voltage back to AC voltage.

When the mains is normal, the rectifier and inverter work together to supply the loads and charge the battery.

When the mains is abnormal, the rectifier stops working, and the battery supplies power to the loads through the inverter. If the battery voltage falls to end of discharge (EOD) voltage and the mains still has not been recovered, the UPS will shut down (if the system uses split bypass configuration and the bypass is normal, the system will transfer to bypass). The battery EOD voltage is preset. When the mains is abnormal, the battery maintains the UPS operation till the battery voltage is reduced to EOD voltage and the UPS shuts down, this time is called 'Backup Time'. The length of backup time depends on the battery capacity and the loads.

1.2.2 Bypass

Through the intelligent control of the 'Static Switch' module (as shown in Figure 1-1) containing the controllable electronic switch, the loads can be supplied by the inverter or the bypass. In normal situation, the loads are supplied by the inverter, in which case the inverter switch at inverter side is closed. In the case of overload (the overload delay time expires) or inverter failure, the inverter switch is opened, and the 'Static Switch' module will automatically transfer the loads to the bypass.

In normal operating state, to realize the uninterrupted transfer between inverter and bypass, the inverter output must be synchronized with the bypass.

Therefore, when the bypass frequency is within the synchronization range, the inverter control circuit will synchronize the inverter output frequency with the bypass frequency and phase.

Besides, the UPS has a manual maintenance bypass switch for shutdown of the UPS upon maintenance. In this situation, the bypass will directly supply the critical loads through the maintenance bypass.

 Note
When the load is supplied by the bypass or maintenance bypass, the power supply quality will be uncertain.

1.2.3 System Control Principle

Normal operation

Normal mode: It means that the UPS has normal input mains, the rectifier and inverter operate normally, the load is supplied by the inverter, the battery circuit breaker is closed, and the battery is in stable floating charge state.

(Parallel System) Note: As the single UPS module outputs are connected in parallel, the system checks that the inverter control circuits are perfectly synchronized with one another and with the bypass in terms of both frequency and phase, and that they have the same output voltages. Current supplied to the load is automatically divided among UPSs. A warning message appears while synchronization is in progress.

Mains abnormal

When the mains fails or is abnormal, the rectifier will stop working automatically, and the system will transfer to battery output (through inverter). The length of the operation time in battery mode depends on the load and the battery capacity. During this period, if the battery voltage falls to the EOD voltage and the mains still has not been recovered, the inverter will stop working automatically, and the UPS operator control and display panel will display corresponding alarm messages. If the system uses split bypass configuration and the bypass is normal, the system will transfer to bypass.

Mains recovery

When the mains resumes normal within allowable time, the rectifier will start automatically (at this time its output power will increase gradually) and supply the load and charge the battery again. Therefore, the power supply to the load will not be interrupted.

Battery disconnection

To disconnect the external battery from the UPS system for maintenance, use the external isolating switch. At this time, except for the battery backup function upon mains failure, other functions and all the steady state performance of the UPS will not be affected.

UPS module failure

In case of inverter failure, inverter switch failure, output fuse blowout and bypass STS failure, the load will automatically transfer to the bypass, and the output power supply will not be interrupted. In this situation, please contact the local customer service center of Vertiv Tech Co., Ltd for technical support.

(Parallel System) In the event of a fault in a UPS module, it will automatically exit from the parallel system. If the system is still capable of providing the required load, the remaining modules will continue to supply the load with no interruption. If the remaining modules are no longer capable of fulfilling power requirements, the load will automatically transfer to the bypass.

Overload

If the inverter is overloaded or the inverter current remains outside the specifications (refer to Table 11-6) longer than the specified time, the load will automatically transfer to the bypass without power interruption. If both the overload and the current are reduced to a level within the specified range, then the load will be transferred back to the inverter. In case of output short circuit, the load will be transferred to the bypass, and the inverter will shut down. Five minutes later, the inverter will start up automatically. If the short circuit is removed at this point, the load will be transferred back to the inverter. The transfer is determined first of all by the features of the protective device of the system.

In the above two situations, the UPS operator control and display panel will display alarm messages.

(Parallel System) The control logic system constantly monitors load requirements and controls the power supplied by each UPS module. In the event that an overload condition is sustained for greater than a preset time, the load will transfer to the bypass, when the number of active modules is unable to satisfy load requirements. The load returns to the inverter if the power is reduced to a value that can be sustained by the number of active modules in the system.

Maintenance bypass

The UPS has a second bypass circuit, i.e. maintenance bypass, which provides a safe working environment for the engineers to provide regular maintenance or repair to the UPS system and at the same time provide unregulated mains supply to the loads. The maintenance bypass can be manually selected through the maintenance bypass switch, and it can be disconnected by turning the switch to OFF.

	Warning
If the UPS system is composed of two or more parallel UPS modules, and the load capacity exceeds the single module capacity, do not use the internal maintenance bypass switch.	

1.2.4 UPS Power Supply Switch Configuration

Figure 1-2 describes the block diagram of the UPS module. The UPS has split bypass configuration (that is, the bypass adopts independent mains input) and common input configuration. In split bypass configuration, the static bypass and maintenance bypass share the same independent bypass power supply. Where a separate power source is not available, the input supply connections of the bypass input switch (Q2) and rectifier input switch (Q1) would be linked together (linked before delivery) to make the bypass input and rectifier input use mains power of the same route.

During the normal operation of the UPS, except for the maintenance bypass switch Q3, other switches shall be closed.

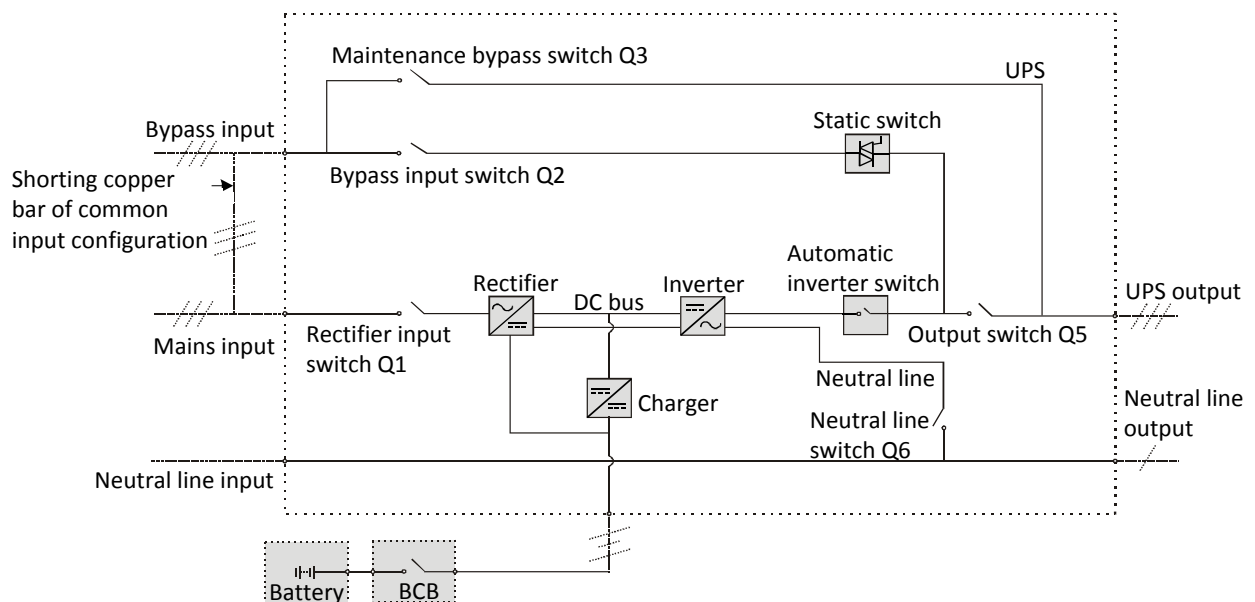

Figure 1-2 UPS power supply switch configuration

1.2.5 Battery Circuit Breaker (BCB)

The external battery shall be connected to the UPS through the BCB. The BCB box is an option, which shall be installed near the battery. The BCB is closed manually or electrically. The BCB has undervoltage tripping coil. Upon battery undervoltage, the UPS control circuit will send a signal to the coil to trip the BCB. It also has a magnetic trip facility for overload protection.

1.3 Parallel System

Up to four UPS modules can be parallel-connected to form a parallel system to increase the system capacity or reliability, or both. The load is equally shared between the paralleled UPS modules.

Moreover, two UPS modules or parallel system can comprise a dual bus system (LBS). Each UPS module or parallel system has independent output. Output synchronization is achieved through the LBS cable, thus enabling seamless load transfer between the two systems.

1.3.1 Parallel System Features

1. The hardware and software of parallel system are completely the same as those of the single module. The parallel system configuration is achieved through settings in configuration software or panel buttons.
2. Parallel cables are connected in a ring, providing both system reliability and redundancy. LBS cables are connected between any two UPS modules of each bus. The intelligent parallel logic provides the user with maximum flexibility. For example, shutting down or starting up UPS modules in a parallel system can be done in any sequence. Transfers between normal mode and bypass mode of operation are seamless and self-recoverable, that is, the overload is cleared, and the system will be automatically recovered to its original operation mode.
3. The total load of the parallel system can be queried from each UPS module's LCD.

1.3.2 Parallel System Requirements

A group of paralleled modules behave as if it were one large UPS with the advantage of presenting higher reliability. To ensure that all modules are equally utilised and to comply with relevant wiring rules, the following requirements apply:

1. All UPS modules must be of the same rating and must be connected to the same bypass source.
2. The bypass and rectifier input sources must be connected to the same neutral line input terminal.
3. Any RCD, if installed, must be of an appropriate setting and located upstream of the common neutral line input terminal. Alternatively, the device must monitor the protective earth current of the system. Refer to *Warning: high earth leakage current* before *Contents*.
4. For parallel system consists of two or more UPS modules, the bypass load sharing inductors (optional) should be selected.

1.4 Operation Modes

The UPS has the following operation modes:

- Normal mode
- Battery mode
- Automatic restart mode
- Bypass mode
- Maintenance mode

- ECO mode
- Parallel redundancy mode (system expansion)
- LBS system mode
- Common battery string mode

Normal mode

As shown in Figure 1-3, the mains is rectified by the UPS rectifier and then inverted by the inverter to supply uninterrupted AC power to the loads. At the same time, the charger will charge the battery.

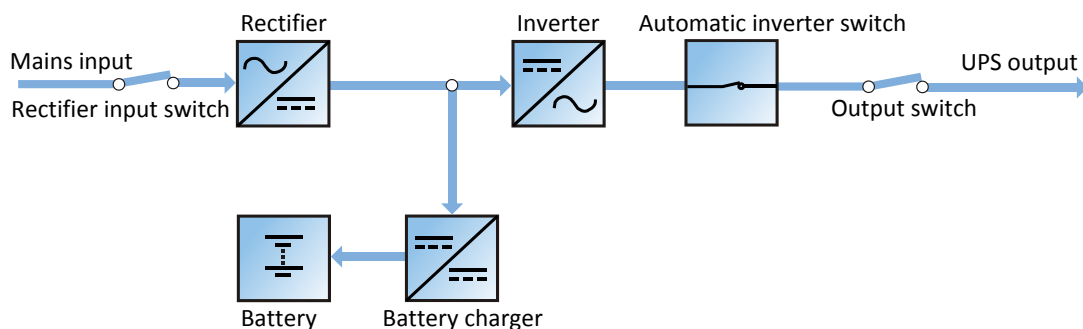

Figure 1-3 Schematic diagram of normal mode

Battery mode

As shown in Figure 1-4, the operation mode in which the battery provides backup power supply to the loads through the rectifier and inverter is called battery mode. Upon mains failure, the system will automatically transfer to the battery mode with no load power interruption. When the mains is recovered, the system will automatically transfer back to the normal mode without any manual intervention, and the power to the load will not be interrupted.

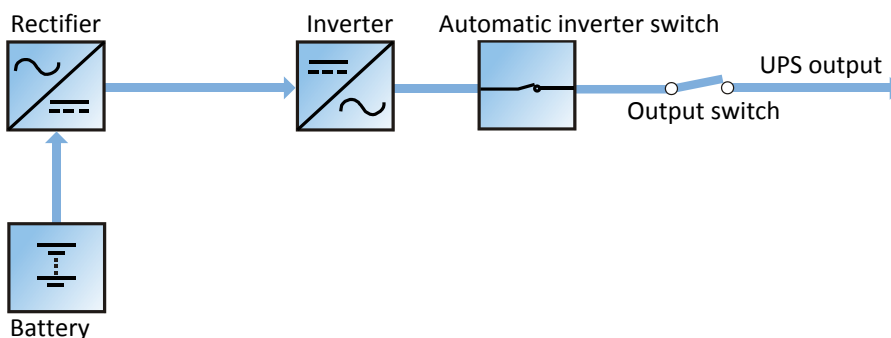

Figure 1-4 Schematic diagram of battery mode

Note: Battery cold start function is available for switching the UPS on from Battery (charged) mode directly during mains failure. Therefore, the battery power supply can be used independently to improve the availability of the UPS.

Automatic restart mode

The UPS has automatic restart function. When the inverter shuts down because the mains fails and the battery discharges to EOD voltage, if the mains is recovered, the UPS will restart automatically after a certain time of delay. This function and the automatic restart type can be set by the service engineer authorized by Vertiv.

During the process of automatic restart time of delay, the UPS will charge the battery to protect against the power-off risk of the load device caused by mains power failure.

If the automatic restart function has not been set, the user can manually start the UPS through pressing the FAULT CLEAR key first and ON key next.

Bypass mode

As shown in Figure 1-5, in normal mode, in case of inverter failure, inverter overload or inverter manual shutdown, the static switch will transfer the load from the inverter side to bypass side, with no interruption in power to the load. At this time, if the inverter and bypass are not synchronized, the power of the load has transitory interruption, with time of less than 20ms.

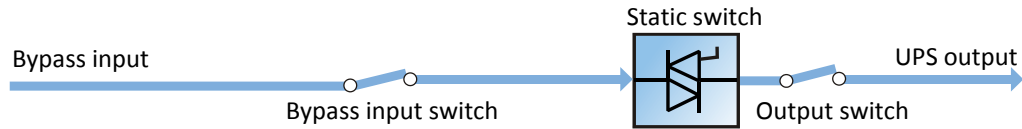

Figure 1-5 Schematic diagram of bypass mode

Maintenance mode

As shown in Figure 1-6, if the UPS maintenance or service is required, you may use the manual maintenance bypass switch to transfer the load to maintenance bypass, with no interruption in power to the load. This maintenance bypass switch is fitted in all UPS modules and rated for full load of one module.

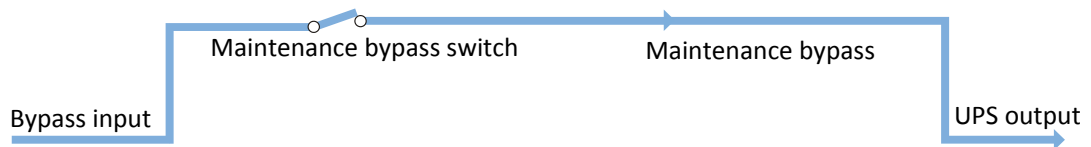

Figure 1-6 Schematic diagram of maintenance mode

ECO mode

If ECO mode is selected, the double-conversion UPS operation is inhibited most of time for the purpose of saving energy. In this mode, the bypass is the preferred source and only when the voltage and/or frequency of the bypass supply are/is beyond the pre-defined threshold the critical AC load is transferred to the inverter: if the inverter is synchronized with the bypass source, the transfer will be instantaneous and during the transfer the output waveform will not exceed the limits set by IEC/EN 62040-3 for a UPS to be classified as VFI-SS-111.

If the inverter is not synchronized with the bypass, in order to avoid hazardous cross current, bypass/inverter changeover is triggered only after a few milliseconds (maximum 20ms) from when bypass has been disconnected from the load. Then, after bypass frequency and voltage have come back and remained within the predefined limits for at least five minutes, the load is automatically and instantaneously transferred back to bypass source.

In this mode, the system can normally charge the battery.

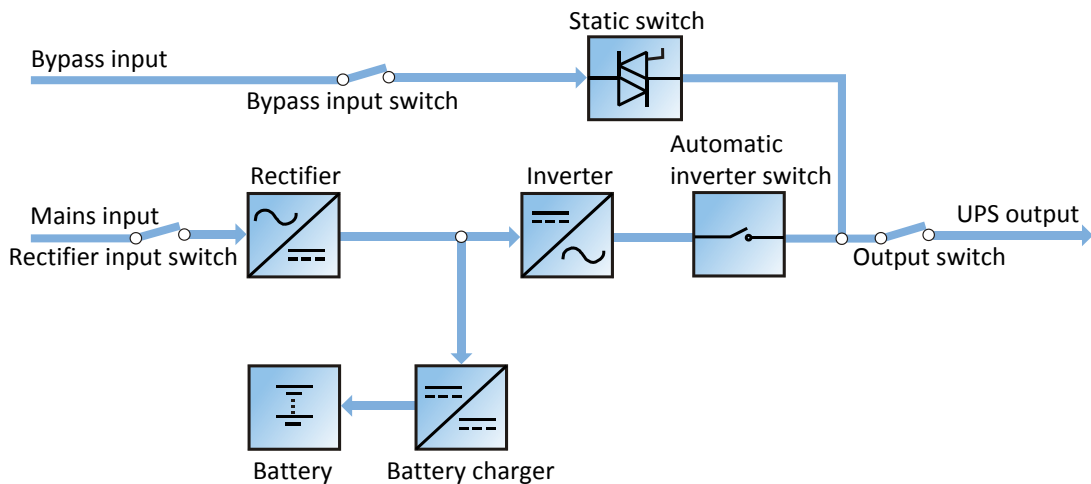



Figure 1-7 Schematic diagram of ECO mode

If ECO mode is required, adjust the corresponding parameters through the operator control and display panel.

The operation method of ECO mode is the same as the description in *Chapter 5 UPS Operation Introduction*. However, in normal mode, the load is powered by the bypass, the inverter indicator is off, and the LCD displays 'Bypass mode', and the transfer interval time is less than 20ms.

	Warning
In ECO mode, the load is not protected against mains distortion.	

Parallel redundancy mode (system expansion)

For higher capacity or higher reliability or both, the outputs of multiple UPS modules can be programmed for directly paralleling while a built-in parallel controller in each UPS module ensures automatic load sharing. The parallel system can be composed of up to four UPS modules. For the operation principle diagram of the parallel redundancy mode, see Figure 7-1.

LBS mode

A dual bus system consists of two independent UPS systems, each containing one or more parallel UPS modules. The dual bus system has high reliability and is suitable for load with multiple inputs. For single-input load, an STS can be installed to power the load. For the operation principle diagram of the LBS mode, see Figure 7-4 and Figure 7-5.

Common battery string mode

It means that when the UPS modules (up to four UPSs) are parallel connected, each UPS module can use the same battery string to achieve the aim of cost-saving, clearance-saving.

	Note
The batteries of different manufacturers, different types and different use time are not allowed to be used together. The common battery string mode is suitable for parallel system only, and does not support the LBS mode.	

1.5 Battery Management

The following battery management functions are set by the service engineer through the Vertiv setting software.

1.5.1 Normal Function

1. Constant current boost charge

Adopt the constant current (within battery charging limit) to charge the battery. The function can be used for battery capacity fast recovery. The charge current can be set.

2. Constant voltage boost charge

Adopt the constant voltage to charge battery. The function can be used for battery capacity fast recovery. For VRLA batteries, the maximum boost charge voltage should not exceed 2.4V/cell.

3. Float charge

The charging method is used for keeping battery with a full capacity. The float charge voltage is generally low. The function can balance the capacity loss due to battery self discharging, and can be used for battery capacity recovery.

For VRLA batteries, the float charge voltage should be between 2.2V/cell and 2.3V/cell.

4. Automatic transfer to float charge

When the charge current is less than 'Threshold of Equalize Charge to Float Charge' or 0.5A, the charger will automatically transfer from boost charge to float charge. When boost charge time exceeds the limit of 'Equalize Charge Protect Time Limit', the charger will be forcibly transferred to float charge for protecting the battery.

5. Float charge temperature compensation (optional)

This function must be used together with the battery temperature detection device. The Vertiv battery temperature sensor is a standard option for your selection.

6. EOD protection

When the battery voltage drops to the EOD voltage, the battery converter shuts down automatically and the battery is isolated to avoid further battery discharge. The EOD voltage is settable from 1.6V/cell to 1.85V/cell (VRLA).

7. Battery low pre-warning time

The battery low pre-warning time is adjustable between 3min and 60min. The default setting is 5min.

8. Maximum battery discharge time

When the battery has small current discharge for a long time, the battery is over discharged and even has unrecoverable damage, thus setting a battery discharge time to protect the battery is essential. The limit of time setting shall be configured by service engineer through the Vertiv setting software.

9. Maximum boost charge protection time

To protect against the battery overcharge damage caused by long time boost charge, a protect time setting is essential. The limit of time setting shall be configured by service engineer through the Vertiv setting software.

1.5.2 Advanced Function

The UPS provides battery maintenance test function. At periodic intervals, 20% of the rated capacity of the battery will be discharged automatically, and the actual three-phase load must exceed 20% of the nominal UPS capacity. If the load is less than 20%, the automatic discharge cannot be executed. The

periodic interval can be set from 30 to 360 days. The battery maintenance test function can be disabled through the Vertiv setting software.

Conditions: Battery at float charge for at least 5h, load equal to 20% ~ 100% of rated UPS capacity.

Trigger: Automatically, or manually through the command of battery maintenance test in LCD.

Interval: 30 ~ 360 days (default setting: 60 days).

The UPS also provides battery capacity self-test function: Periodically test the battery activity, test the battery residual capacity, judge the battery quality, and then provide the corresponding measures. The capacity self-test is started by the user through the operator control and display panel. During the capacity self-test, the battery will continuously discharge to the battery undervoltage shutdown threshold. After the self-test is finished, the system will update the battery curve table. The capacity self-test command is valid only one time, without any memory. During the capacity self-test, if the battery maintenance requirement is satisfied, the system will generate audible/visual alarm and give corresponding records.

Conditions: System load rate within 20% ~ 100%, battery float charge at least 5h, and generator not connected; the current system is in float charge state.

Trigger: Start up through the LCD.

Note:

1. The battery will continuously discharge to the battery undervoltage shutdown threshold, then the battery transfer to the charging state. When the capacity self-test is finished, the system will update the battery curve table.
2. The user can manually stop the capacity self-test operation through the LCD.

1.5.3 Battery Temperature Compensation

The UPS system has battery charge temperature compensation function. When the ambient temperature is increased, the DC bus voltage (which charges the battery) will be reduced correspondingly to provide optimal charging voltage for the battery, thus prolonging the battery service life time.

This function must be used together with the Vertiv battery temperature detection device (a standard option).

1.6 Battery Protection

The following battery protection functions are set by the service engineer through the Vertiv setting software.

Battery low pre-warning

The battery low pre-warning occurs before the EOD. After this pre-warning, the battery should have the capacity for three remaining minutes discharging with full load. The time can be configured from 3min to 60min.

EOD protection

When the battery voltage drops to the EOD voltage, the battery converter shuts down automatically. The EOD voltage is adjustable from 1.6V/cell to 1.85V/cell (VRLA).

BCB alarm

The BCB alarm occurs when the external BCB opens, if you select the Vertiv BCB (optional).

The external battery connects to the UPS through the BCB. The BCB is manually closed and tripped by the UPS control circuit.

Chapter 2 Mechanical Installation

This chapter briefly introduces the mechanical installation of the UPS, including the precautions, initial inspection before installation, environmental requirement, mechanical requirement and installation diagram.

2.1 Precautions

This chapter describes the environmental and mechanical requirements and mechanical considerations that must be taken into account when planning the positioning and cabling of the UPS equipment.

Because each site has its particular characteristics, this chapter does not provide the detailed installation steps, it only acts as a guide for the general procedures and practices that should be observed by the installing engineer, so that they can properly handle the specific situation of the site.



Warning: professional installation required

1. Do not disassemble the package without permission of authorized service engineer.
2. The UPS should be installed by an authorized engineer in accordance with the information contained in this chapter.



Warning: battery danger

Take special care when installing batteries. When connecting batteries, the battery terminal voltage will reach 320Vdc, which is fatal to human being.

1. Please wear safety glasses to protect the eyes from being damaged by arc.
2. Remove all the metal items, including finger rings, watch, etc.
3. Use tools with insulated handle.
4. Wear rubber gloves.
5. If the battery has electrolyte leakage or the battery is damaged, it must be replaced. Place the battery into the container that can withstand sulfuric acid and dispose of it according to the local regulations.
6. If the skin contacts the electrolyte, flush it with water immediately.

2.2 Transportation

Railroad transportation and shipping are the recommended means of transportation. If truck transportation is unavoidable, choose roads that are less bumpy in order to protect the equipment.

The UPS cabinet is heavy (see Table 11-3 for the weight). It is recommended to use mechanical equipment such as an electric forklift to unload and move the equipment to the place closest to the installation site. If an electric forklift is used, insert the tines of the forklift below the bottom pallet (as shown in Figure 2-1) to prevent the equipment from falling over.



Figure 2-1 Inserting and movement

2.3 Unpacking

Unpack the UPS and battery packages under the guidance of authorized service engineer. Steps:

1. Remove the side panels and top cover.

Use a hammer or straight screwdriver to straighten the connection hook that connects the side panels to the top cover, as shown in Figure 2-2.



Figure 2-2 Straightening the hook

At first, straighten all the hooks that fix side panel I, and remove side panel I. Then straighten all the hooks that fix side panel II, and remove side panel II. At last remove top cover III, as shown in Figure 2-3.

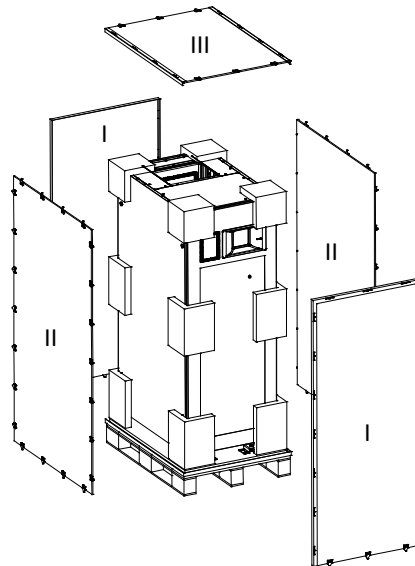

Figure 2-3 Removing side panels and top cover

2. Remove the fixing bolts of the bottom pallet (see Figure 2-4), and reserve the fixing bolts. Then use the forklift (following the inserting direction shown in Figure 2-4) to move the cabinet near the installation place.

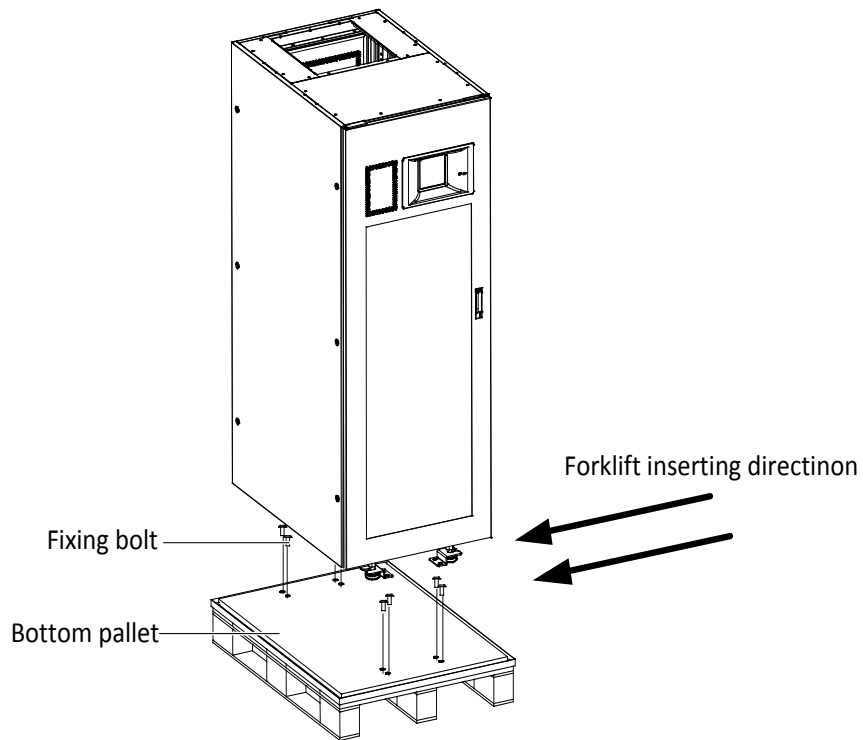
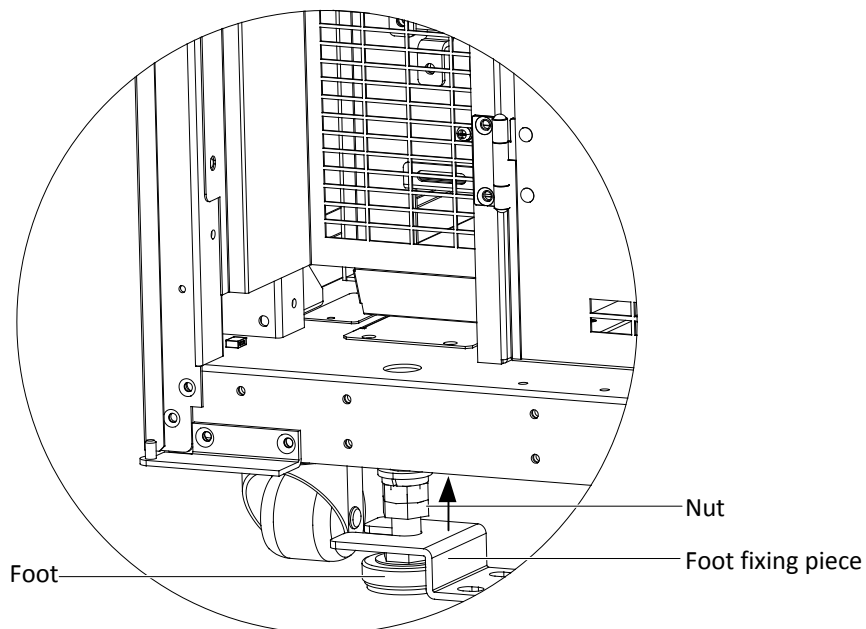

Figure 2-4 Removing bottom pallet

3. After moving the cabinet to the installation place, you should raise the four adjustable feet, and then use the castors to move the cabinet to its final installation site.

Method of raising one foot: as shown in Figure 2-5, first loosen the nut (installed in factory) from bottom to top, and remove the foot fixing piece (reserve it), then rotate the foot to raise it for avoiding affecting the side of the castor.



Lower left corner of the cabinet (amplified view)

Figure 2-5 Schematic diagram for raising the foot

4. Open the UPS front door, loosen the six fixing screws and remove the two fixing bars in left drawing in Figure 2-6, and then reinstall the fixing screws to their original positions, see right drawing in Figure 2-6.

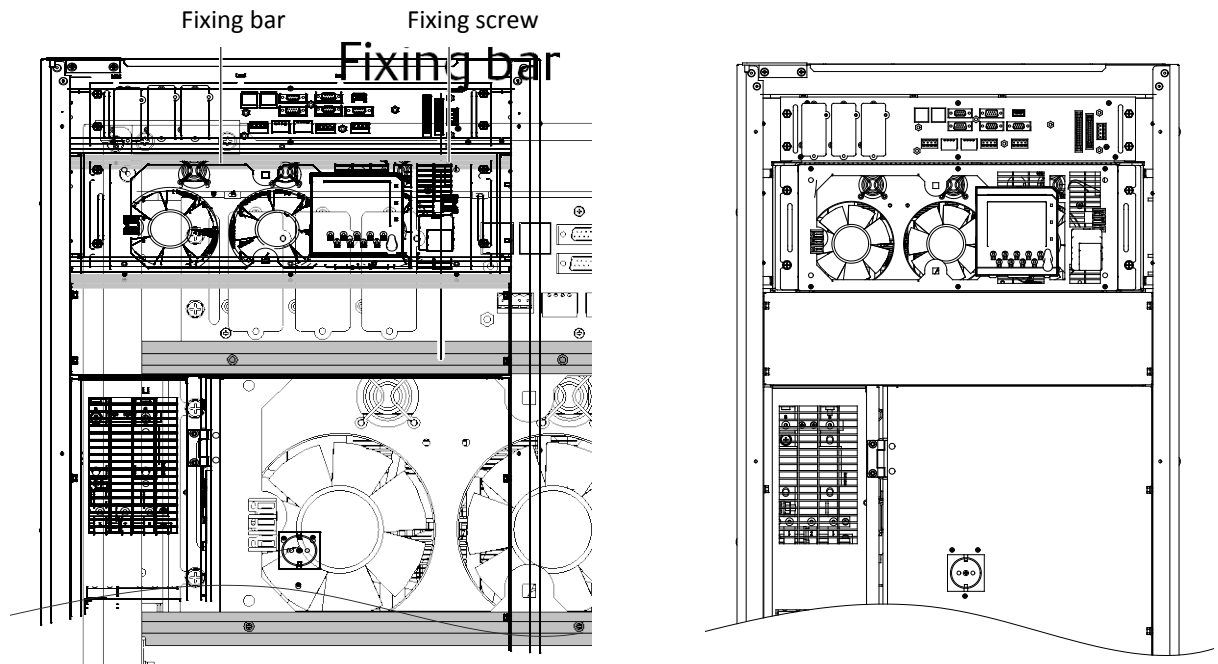

Figure 2-6 Removing fixing bars

2.4 Initial Inspection

Before installing the UPS, carry out the following inspections:

1. Ensure that the environment of the UPS equipment room meets the environmental requirement specified in the product technical specifications, especially the ambient temperature, ventilation conditions, and the dust situations.
2. Unpack the UPS and battery under the guidance of authorized service engineer. Visually inspect whether the inside and outside of the UPS and battery have any transportation damage. If there is any damage, report to the carrier immediately.
3. Verify the UPS label and confirm the correctness of the UPS. The UPS label is attached on the back of the door. The UPS model, capacity and main parameters are marked on the label.

2.5 Environmental Requirement

2.5.1 UPS Location Selection

The UPS should be located in a cool, dry, clean-air indoor environment with adequate ventilation, and should be located on concrete or other nonflammable and flat surfaces. The ambient environment should be free of conductive powder (such as metallic powder, sulfide, sulfur dioxide, graphite, carbon fiber, conductive fiber, etc.), acid mist or other conductive media (strongly ionized substances). The environment specifications should comply with relevant international standard & specifications and the operating range (see Table 11-2) specified in this manual.

The UPS uses forced cooling by internal fans. Cooling air enters the UPS through the ventilation grills at the front of the cabinet and exhausted through the ventilation grills at the back of the cabinet. Do not obstruct the ventilation holes (ventilation grills). The rear of the UPS should be kept a distance at least

200mm from the wall to avoid blocking the UPS heat dissipation, thus reducing the UPS internal temperature and improving the UPS life.

If necessary, install indoor extractor fans to aid cooling-air flow to avoid room temperature buildup. Air filters (optional) should be used when the UPS is to operate in a dirty environment.

Note 1: When the battery cabinet is installed near the UPS, the maximum allowable ambient temperature is dependent on the battery rather than the UPS.

Note 2: If the UPS is working in ECO mode, the power consumption will be less than that in Normal mode. Proper air conditioning system shall be selected according to the normal operating mode.

2.5.2 Battery Location Selection

Batteries generate some amount of hydrogen and oxygen at the end of charge, so the fresh air volume of the battery installation environment must meet the EN50272-2001 requirements.

The ambient temperature is the main factor that affects the battery capacity and life. The normal operating temperature of the battery is 20°C. If the ambient temperature is higher than 20°C, the battery life will be reduced. If it is lower than 20°C, the battery capacity will be reduced. In normal situation, the allowable ambient temperature for the battery is 15°C to 25°C. The ambient temperature of the battery shall be maintained constant, and the battery shall be kept away from heat source and air outlet.

Battery can be installed inside the specialized battery cabinet which shall be close to the UPS. If the battery is placed on the raised floor, bracket shall be installed under the floor, just as for the UPS. If the battery adopts rack mounting or is mounted far from the UPS with other installation mode, the battery circuit breaker shall be installed near the battery, and the cabling distance shall be minimized.

2.5.3 Storage

Should the UPS not be installed immediately, it must be stored with the original packaging in a room for protection against excessive humidity and heat sources (see Table 11-2). The battery needs to be stored in a dry and cool place with good ventilation. The most suitable storage temperature ranges from 20°C to 25°C.



Warning

During battery storage, periodically charge the battery according to the battery manufacturer instructions. In the charge process, temporarily connect the UPS to the mains and activate the battery by recharging the battery.

2.6 Mechanical Requirement

2.6.1 Moving Cabinet



Warning

1. The lifting equipment for moving the UPS cabinet shall have enough lift capacity.
2. The UPS has installed castors. When removing the UPS from the shipping pallet, pay attention to keeping the UPS from sliding. Ensure that adequate personnel and lifting equipment are available when removing the shipping pallet.
3. Due to its intensity, the castors may be valid only on the flat surface.
4. The gravity center of the UPS cabinet is high, avoid falling over during the cabinet movement.
5. Vertical hanging of cabinet is not allowed.

**Caution**

Take special care when moving the battery cabinet fitted with batteries, in which case, you must fasten each battery string, and try to minimize the movement distance.

Ensure that the UPS weight does not exceed the capacity of the lifting equipment. For the UPS weight, refer to Table 11-3.

The UPS cabinet can be moved by forklift or other similar lifting equipment.

For short distance movement, the castors can be used.

2.6.2 Clearance

Because the UPS has no grill at the two sides, there is no special clearance requirement on the two sides.

Besides the local regulations, to enable routine tightening of the power terminals within the UPS, it is recommended that clearance around the front of the UPS should be sufficient to enable free passage of personnel with the door fully open. Meanwhile, maintain at the back of the cabinet a clearance at least 200mm to permit adequate circulation of air coming out of the UPS.

2.6.3 Cable Access Mode

The UPS adopts top cable access method and bottom cable access method.

For details, refer to 3.1.10 *Power Cable Connection Steps* and 3.2.11 *Signal Cable Connection Steps*.

2.6.4 Final Positioning And Fixing

After the final positioning of the UPS, use the four adjustable feet to fix the UPS on the floor, as shown in Figure 2-7. Method:

1. Loosen the nuts from bottom to top.
2. Rotate the feet down to touch the floor.
3. Plug the foot fixing pieces to the feet.
4. Align the foot fixing pieces with the installation holes dug according to dimensions shown in Figure 2-8.
5. Rotate the nuts from top to bottom till the nuts firmly press the foot fixing pieces, and then use the fixing bolts M10 to fix the UPS on the floor.

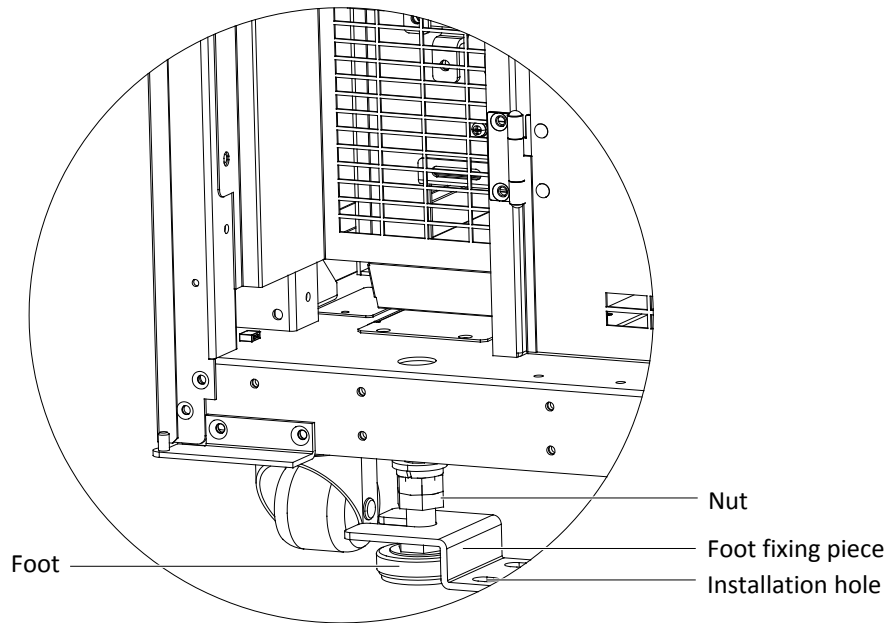

Lower left corner of the cabinet (amplified view)

Figure 2-7 Schematic diagram for UPS positioning and fixing

2.7 Installation Drawings

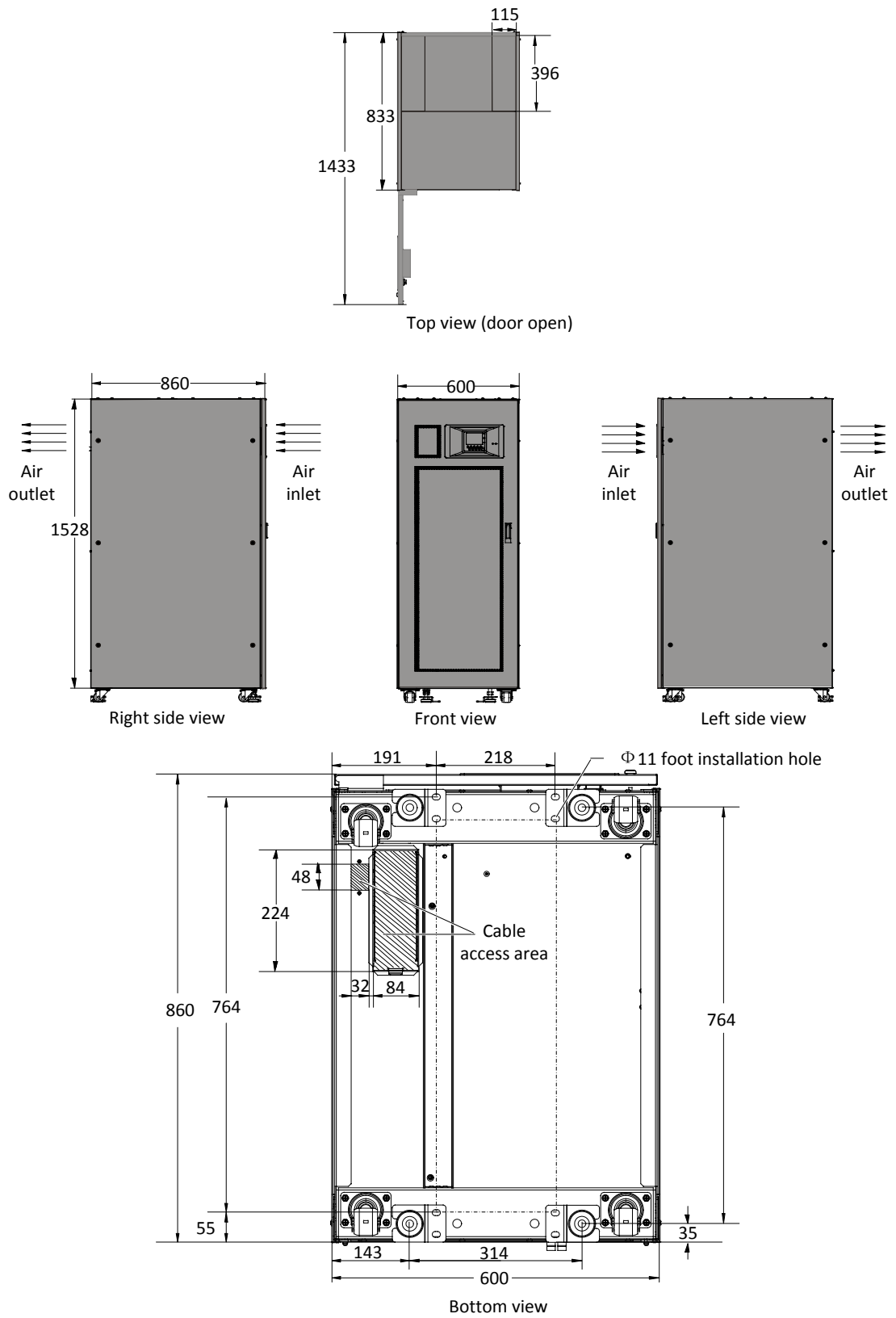



Figure 2-8 Top/front/side/bottom view of the UPS (unit: mm)

Chapter 3 Electrical Installation

This chapter mainly introduces the electrical installation of the UPS, including the power cable and signal cable connecting procedures and methods.

After completing the mechanical installation of the UPS, it is required to connect the power cable and signal cable of the UPS. All the signal cables, whether shielded or not, shall be kept away from the power cables.

	Warning
<ol style="list-style-type: none"> 1. Do not power on the UPS before the arrival of authorized service engineer. 2. The UPS cables should be routed by an authorized engineer in accordance with the information contained in this chapter. 	

3.1 Wiring Of Power Cable

3.1.1 System Configuration

The cable size of the system power cable shall meet the following requirements:

UPS input cable

The cable size of the UPS input cable differs with the UPS power ratings and input AC voltages, provided that it meets the requirement of maximum input current, including the maximum battery charge current, see Table 3-1.

UPS bypass and output cable

The cable size of the UPS bypass and output cable differs with the UPS power rating and output AC voltages, provided that it meets the requirement of nominal output or bypass current, as shown in Table 3-1.

Battery cable

Each UPS connects to its battery through the three cables connecting to the positive pole, negative pole and neutral line. The cable size of the battery cable differs with the UPS power ratings, provided that it meets the battery discharge current requirement when the battery discharges to near EOD voltage, as shown in Table 3-1.

3.1.2 Maximum Steady State AC And DC Currents

The power cable must be selected according to the current and voltage values in Table 3-1 as well as the local wiring regulations, and take environmental conditions (temperature and physical media) into consideration, then refer to Table 3B in IEC 60950-1.

Table 3-1 Max. steady state AC and DC currents

UPS power (kVA)	Rated current (A)			Bus stud bolt/nut specification	
	Max. input	Output/bypass current ² at full load	Battery discharge current (+, -, N) at	Input/battery/output/	Recommended torque (N.m)

	current ¹²	380V	400 V	415V	min. battery voltage	bypass cable	
30 (3-in 3-out)	53	46	44	42	96/96/20	M6/M8/M6/M 6	4.8/12/4.8/4.8
30 (3-in 1-out)	55	137	132	126	96/96/20	M6/M8/M8/M 8	4.8/12/4.8/4.8
40 (3-in 3-out)	68	61	58	56	127/127/25	M6/M8/M6/M 6	4.8/12/4.8/4.8
40 (3-in 1-out)	71	182	174	168	127/127/25	M6/M8/M8/M 8	4.8/12/4.8/4.8

**Note**

When selecting the battery cables, a max. volt drop of 4Vdc is permissible at the current ratings given in Table 3-1. Do not form coils, so as to minimize the formation of EMI.

1. Input mains current for rectifier and bypass.
2. Non-linear load (like switch power) affects the design of output and bypass neutral line. The neutral line current may exceed the rated phase current, at most 1.5 times of the rated phase current.

3.1.3 Recommended CSA Of UPS Cable

The recommended CSA of the UPS cable is listed in Table 3-2.

Table 3-2 Recommended CSA of the UPS cable (unit: mm², ambient temperature: 25°C)

Model	Input	Output	Bypass	Neutral line	Earth cable	Battery
30kVA (3-in 3-out)	16	16	16	25	16	35
30kVA (3-in 1-out)	16	50	50	50	16	35
40kVA (3-in 3-out)	16	16	16	25	16	35
40kVA (3-in 1-out)	16	50	50	50	16	35

**Note**

Input cables of no less than 50mm² (phase A) must be used for common source configuration in 3-in 1-out mode.

3.1.4 Selection Of UPS I/O Switch

Table 3-3 is the recommended UPS I/O switch capacity, and the user can select it according to actual needs.

**Note**

The specified upstream breakers below are required to obtain the conditional short-circuit current rating, I_{cc} at 10kA symmetrical rms. The specified upstream breakers should comply with an IEC 60947 series standard.

Table 3-3 Selection of the UPS I/O switch

Model	Input port	Recommended capacity of input external switch	BCB	Output port	Recommended capacity of output external switch
30kVA (3-in 3-out)	Terminal block	I _{cc} =10kA\U _c =230/400V main 63A (3P), bypass 100A (3P)	DC 160A (4P)	Terminal block	63A (3P)
30kVA (3-in 1-out)	Terminal block	I _{cc} =10kA\U _c =230/400V main 63A (3P),	DC 160A (4P)	Terminal block	160A (1P)

Model	Input port	Recommended capacity of input external switch	BCB	Output port	Recommended capacity of output external switch
		bypass 160A (1P)			
40kVA (3-in 3-out)	Terminal block	Icc=10kA\Uc=230/400V main 100A (3P), bypass 125A (3P)	DC 160A (4P)	Terminal block	100A (3P)
40kVA (3-in 1-out)	Terminal block	Icc=10kA\Uc=230/400V main 100A (3P), bypass 250A (1P)	DC 160A (4P)	Terminal block	250A (1P)



Note

1. The bypass switch (125A) is recommended for common source configuration in 3-in 3-out mode.
2. The bypass switch (250A) is recommended for common source configuration in 3-in 1-out mode.

3.1.5 Distance Between The UPS Connection Point And The Floor

See Table 3-4 for details.

Table 3-4 Min. distance between UPS connection point and floor

UPS connection point	Min. distance (mm)	
	30kVA	40kVA
Rectifier input	345	345
Bypass input	284	284
AC Output	250	250
Battery	994	994
PE terminal	740	740

3.1.6 Notes

The following points are for general guidance only. If there are relevant local regulations, the local regulations shall prevail.

1. The cable size of the neutral line shall be selected according to 1.5 times of the output/bypass phase current.
2. The cable size of the protective earth cable shall be selected according to the AC power failure level, cable length and protection type. The grounding wire connection must use the shortest connection route.
3. For the cables with large current, parallel connection of small cables can be adopted to facilitate the installation.
4. When selecting the battery cable size, the current value in Table 3-1 shall be referred to, and a maximum voltage drop of 4Vdc is allowed.
5. Do not form coils, so as to minimize the formation of EMI.

3.1.7 Power Cable Connecting Terminal

The rectifier input, bypass input, output and battery power cables are connected to the corresponding terminals shown in Figure 3-2.

3.1.8 Protection Ground

The protective earth cable is reliably connected to the PE input terminal (see Figure 3-2) via the fixing bolt. All the cabinets and cable troughs shall be grounded according to the local regulations. The grounding wires shall be tied up reliably to prevent the loosening of the grounding wire tightening screws when the grounding wires are pulled.

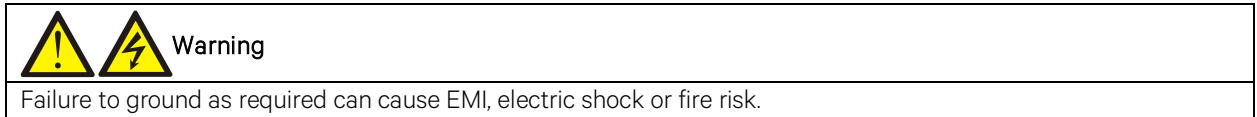

3.1.9 External Protective Device

To ensure the safety, it is necessary to install external circuit breaker for the input and battery of the UPS. Because of the difference of the specific installations, this section only provides general practical information for the installation engineer. The qualified installation engineer should have the knowledge of the local wiring regulations on the equipment to be installed.

Rectifier and bypass input power supply

1. Input overcurrent and short circuit protection

Install suitable protective devices in the distribution line of the incoming mains supply. The protective devices should provide functions such as the overcurrent protection, short circuit protection, isolation protection and tripping upon backfeed. When selecting the protective devices, consider the power cable current-carrying capacity, system overload capacity (see Table 11-6 and Table 11-7) and the short circuit capability of the upstream power distribution. It is generally recommended to use the thermomagnetic circuit breaker of IEC60947-2 tripping curve C (normal), when the current value reaches 125% of the current value listed in Table 3-1.

2. Split bypass configuration

If the UPS adopts split bypass configuration, independent protective device shall be installed respectively on the rectifier input and bypass input distribution lines.

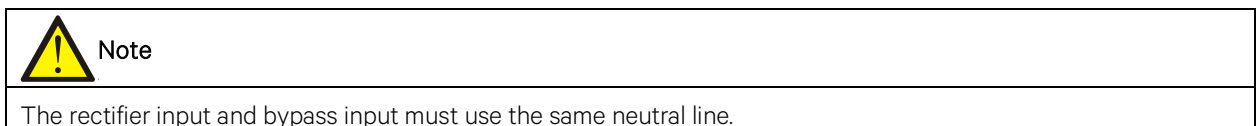

3. Ground fault protection

If the pre-stage input power supply has an RCD, the transient state and steady state ground leakage current upon the startup of the UPS shall be considered.

The RCCB shall meet the following requirements:

- Be sensitive to the DC unidirectional pulse (class A) of the whole distribution network
- Be insensitive to transient state current pulse
- Have an average sensitivity which is 0.3A ~ 3A adjustable

The RCCB symbols are shown in Figure 3-1.

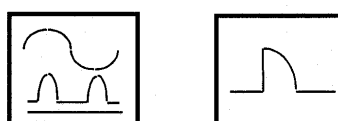

Figure 3-1 RCCB symbols

The UPS has an internal EMC filter, therefore the protective earth cable has leakage current which is 0 ~ 1000mA. It is recommended to confirm the RCD sensitivity of the upstream input distribution and the downstream distribution (to the load).

External battery

The BCB is useful for protecting the external battery. The UPS provides an optional BCB box to provide overcurrent protection, short circuit protection and automatic tripping functions for the external battery. The rated voltage of the BCB is 500Vdc, and its DC breaking current is 20kA.

This BCB is important for the battery maintenance, and is generally installed near the battery.

System output

The UPS output distribution shall be configured with a protective device. The protective device shall be different from the input distribution protection switch and able to provide overload protection (refer to Table 11-6 and Table 11-7).

3.1.10 Power Cable Connection Steps

For cable access mode of the UPS, refer to 2.6.3 *Cable Access Mode*.

Connection terminal and cable routing method

Figure 3-2 shows the UPS power cable connection terminals. Figure 3-3 and Figure 3-4 show the power cable entry and routing methods.



Note

1. The power cables should be routed through tunnels or cable troughs to prevent cable damage due to mechanical stress.
2. When routing the cables inside the cabinets, it is required to bind and fix the cables as instructed in Figure 3-3 and Figure 3-4 in the cabinets, so as to prevent cable damage due to mechanical stress.

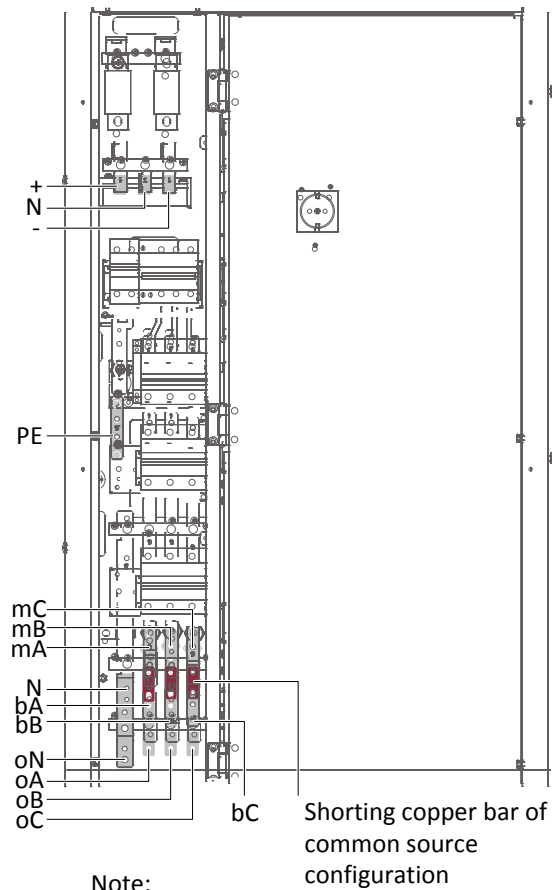

Note:

1. +, -, N: battery input terminals
2. PE: PE input terminal
3. mA, mB, mC: rectifier input terminals
4. bA, bB, bC, N: bypass input terminals
5. oA, oB, oC, oN: output terminals

Figure 3-2 Power cable connection terminals

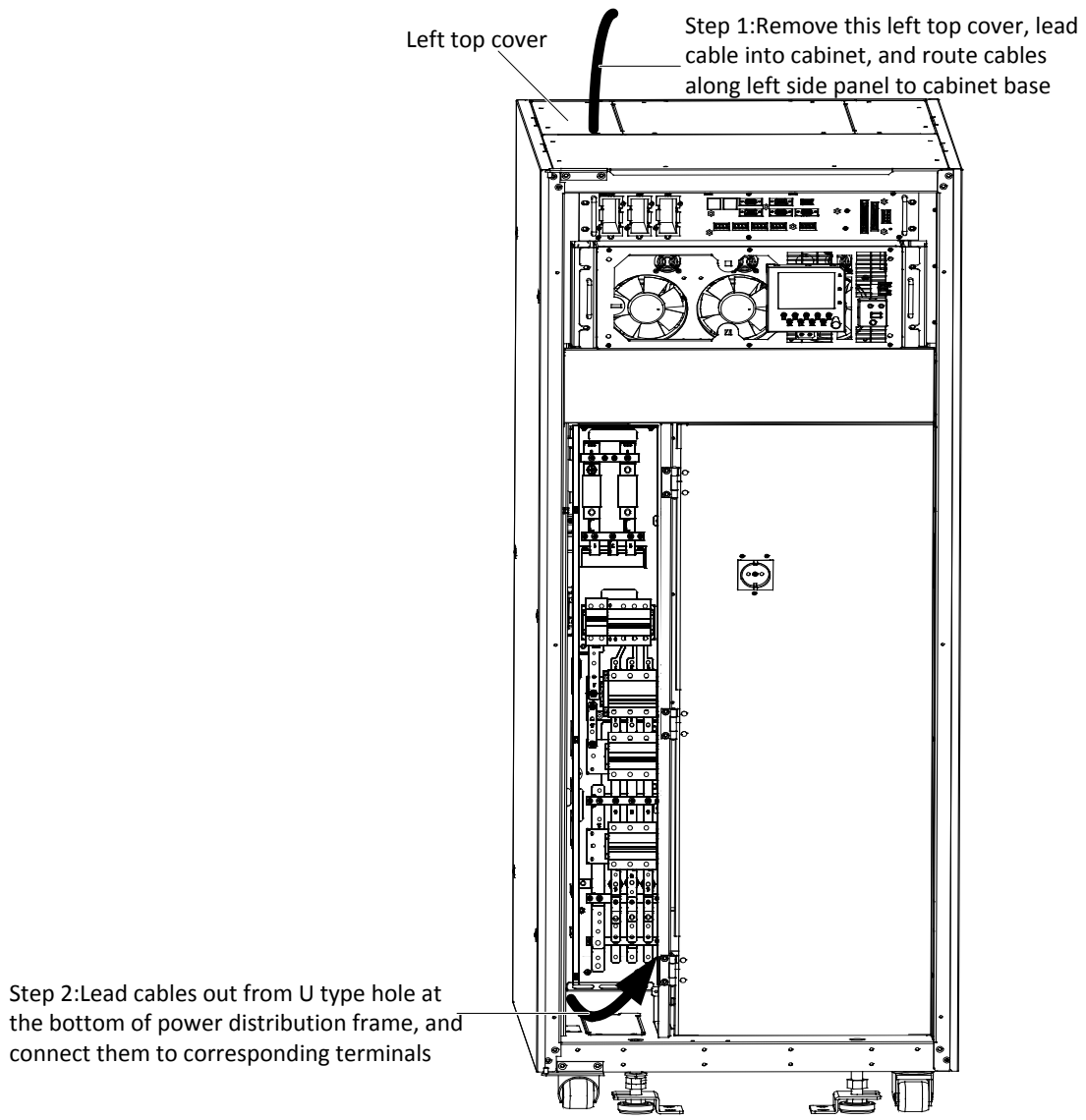

Figure 3-3 Power cables wiring route (top cable access)

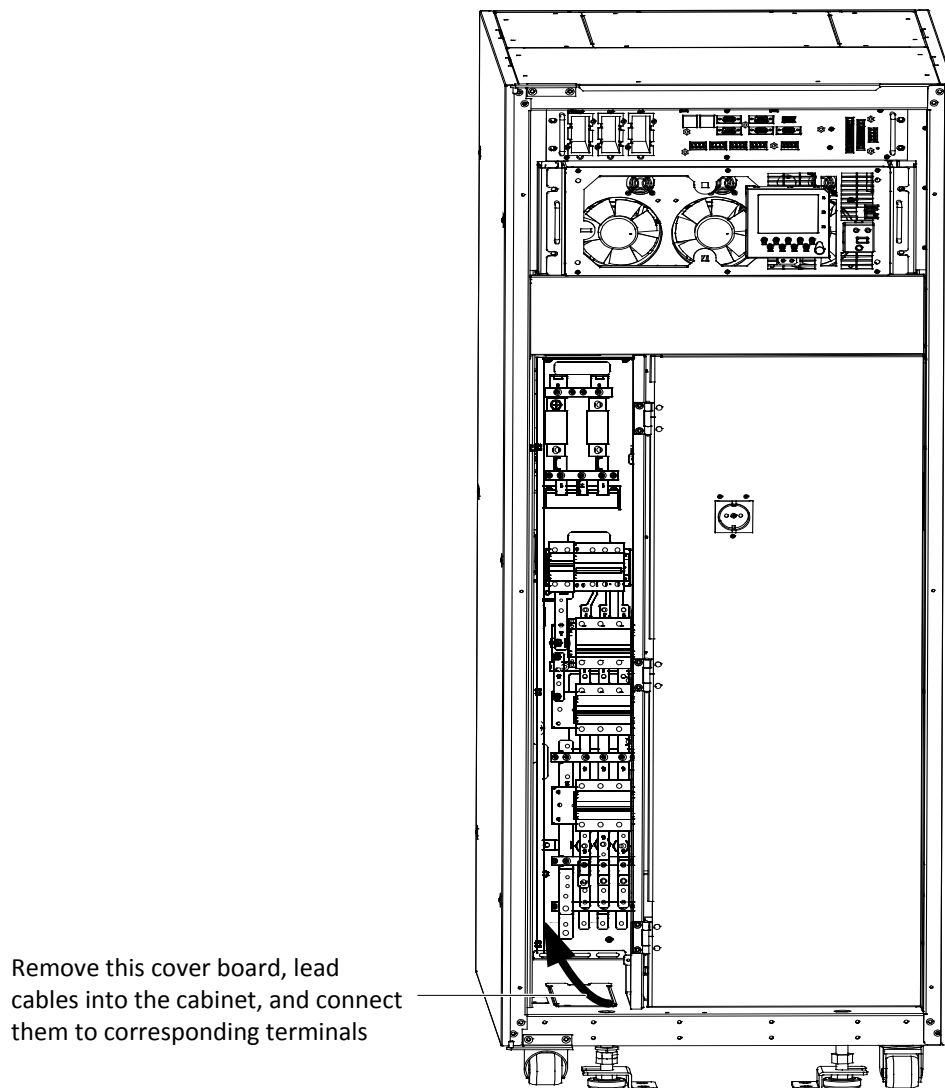

Figure 3-4 Power cables wiring route (bottom cable access)



Warning

Before cables connection, make sure that all external and internal power switches of the UPS are off, and post necessary warning signs to prevent inadvertent operation of the switches. Meanwhile, measure the voltages between the UPS terminals and the voltages between the terminals and the earth.

Refer to Figure 3-2 ~ Figure 3-4, open the front door of the UPS, and remove the protective cover (located at the lower left corner) to reveal the power cable connection terminals (see Figure 3-2). Connect the protective earth cable to the PE input terminal in the cabinet.



Warning

1. The earth cables and neutral line must be connected in accordance with local and national codes of practice.
2. Failure to observe this could result in electric shock or fire risk.

Power distribution mode

According to the user's requirements, the I/O cable connections can be configured into four types:

- 3-in 3-out, common source configuration (factory default)
- 3-in 3-out, split bypass configuration

- 3-in 1-out, common source configuration
- 3-in 1-out, split bypass configuration

Connection of system input

1. 3-in 3-out, common source configuration (factory default)

Refer to Figure 3-5, connect the AC input cables to the bypass input terminals (bA-bB-bC) in the cabinet, and ensure that the three shorting copper bars between the rectifier input terminals (mA-mB-mC) and the bypass input terminals are connected correspondingly. Connect the input neutral line to the neutral terminal N in the cabinet. Ensure correct phase rotation.

Note that the shorting copper bar of common source has been configured before delivery.

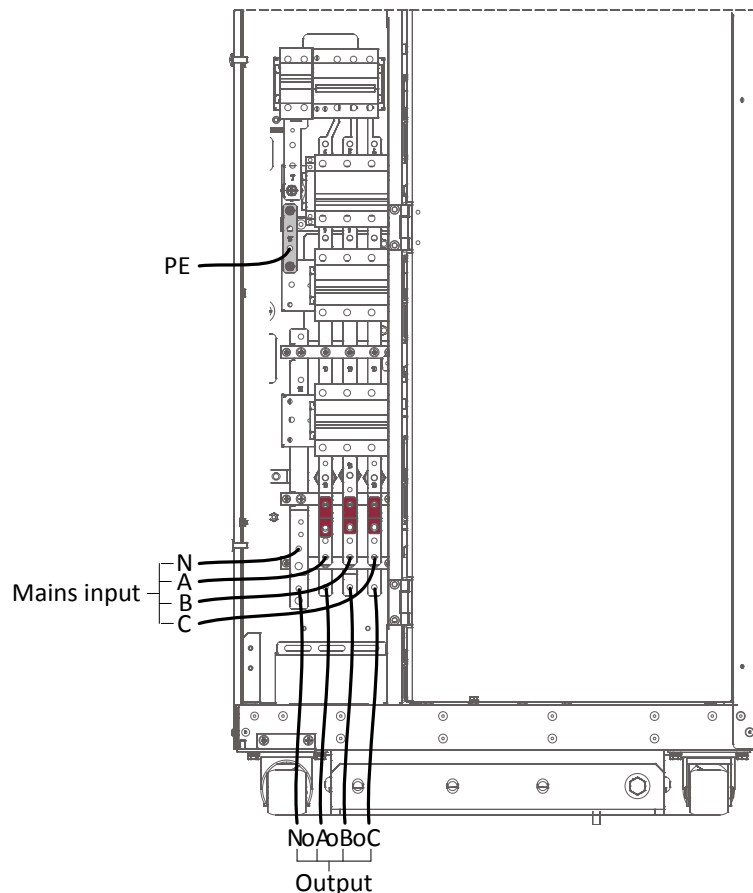

Figure 3-5 3-in 3-out, common source configuration cable connection (factory default)

2. 3-in 3-out, split bypass configuration

Refer to Figure 3-6, remove the three shorting copper bars between the rectifier input terminals (mA-mB-mC) and the bypass input terminals (bA-bB-bC). Connect the rectifier input cables to the rectifier input terminals (mA-mB-mC) in the cabinet, and connect the bypass input cables to the bypass input terminals (bA-bB-bC) in the cabinet. Connect the rectifier input neutral line and bypass neutral line to the neutral terminal N in the cabinet. Ensure correct phase rotation.

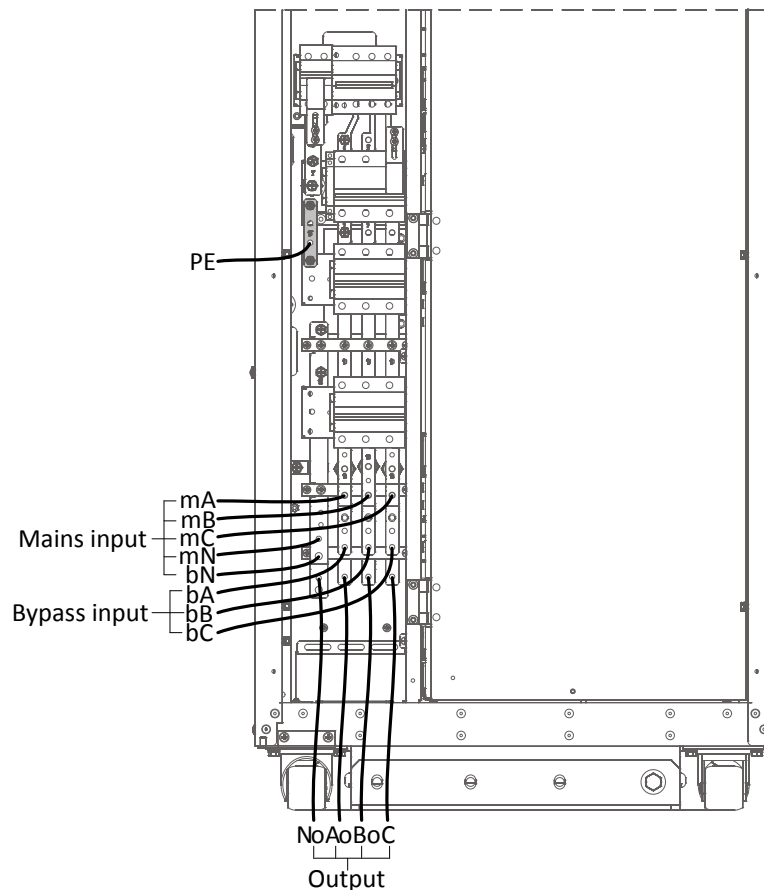

Figure 3-6 3-in 3-out, split bypass configuration cable connection

3. 3-in 1-out, common source configuration

For details, see 8.2.13 3-in 1-out Copper Bar Kit.

4. 3-in 1-out, split bypass configuration

For details, see 8.2.13 3-in 1-out Copper Bar Kit.

Connection of system output

Connect the system output cables between the output terminals (oA-oB-oC-oN) in the cabinet and the load. Refer to Table 3-1 for the torque. Ensure correct phase rotation.



Warning

If the load will not be ready to accept power supply before arrival of the service engineer, ensure that the system output cables are safely isolated at their ends.

Connection of batteries

If the external battery is required, ensure correct polarity of the connections from the battery string terminals to the BCB and from the BCB to the battery input terminals (BAT+, BAT N, BAT-) in the UPS cabinet, that is, (BAT+) to (+) and (BAT-) to (-), (BAT N) to (N), but disconnect one or more battery cell links in each tier. Do not reconnect these links and do not close the BCB before authorized to do so by the service engineer.

Note: When connecting the cables between battery terminals and BCB, the connection should begin from the BCB terminal.

Now, the connection is finished. Then replace the protective covers.

**Note**

After connection, take appropriate measures to seal the cable entry holes.

3.2 Wiring Of Signal Cable

3.2.1 Overview

For on-site specific needs, the UPS needs auxiliary connection to realize battery system (including the external battery switch) management, communicate with PC, provide alarm signal to external devices, realize remote EPO or provide bypass back feed circuit breaker signal and parallel communication. These functions are realized through the communication box in the UPS cabinet. As shown in Figure 3-7, the communication box provides the following ports:

- User dry contact port
- RS232 communication port
- USB communication port
- Parallel communication port
- LBS communication port
- RS485 communication port
- Intellislot port

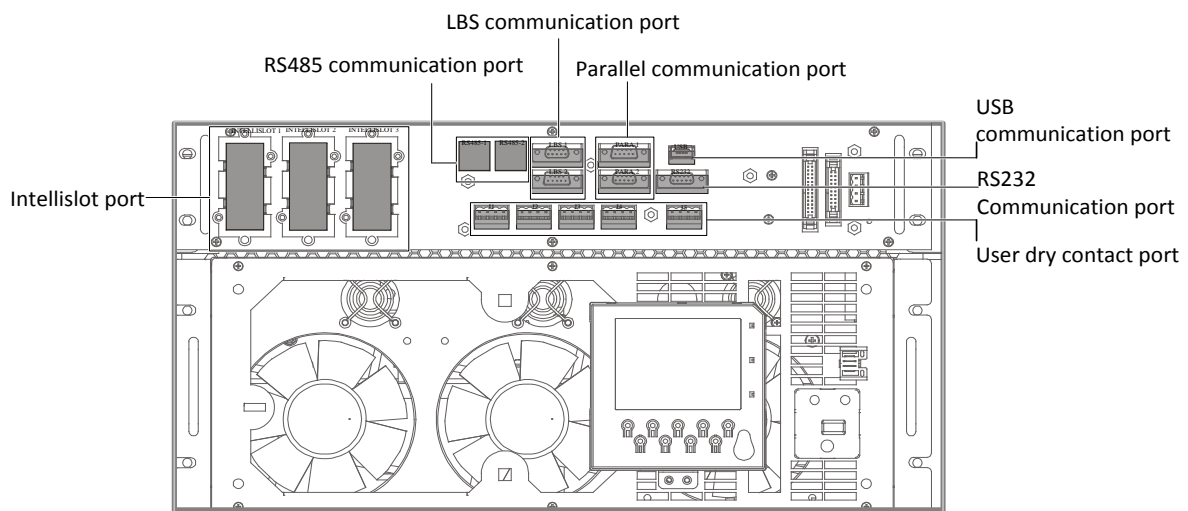

Figure 3-7 Illustration drawing of communication box ports

3.2.2 Input Dry Contact Port

The input dry contact ports J1 and J2 are shown in Figure 3-8 and described in Table 3-5. The input dry contact voltage is 12Vdc, and the current is 20mA.

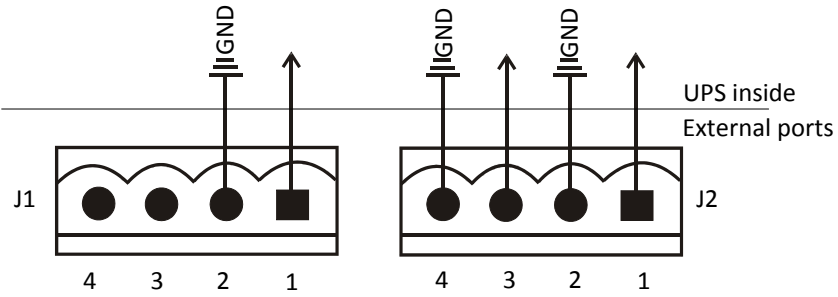

Figure 3-8 Input dry contact ports J1 and J2

Table 3-5 Description of input dry contact ports J1 and J2

Silkscreen	Port	Pin No.	Pin name	Meanings
J1	Generator mode input	1.1	GEN	Generator is connected. Shorted to 1.1 and 1.2: generator mode; opened to 1.1 and 1.2: normal mode
		1.2	GND	GND
J2	External maintenance bypass switch	2.1	EXT_Q3	External maintenance bypass switch state. The auxiliary contact requirement of the external maintenance bypass switch: when 2.1 and 2.2 are shorted, the external maintenance bypass switch is closed
		2.2	GND	GND
	External output switch	2.3	EXT_OUT	External output switch. The auxiliary contact requirement of the external output switch: when 2.3 and 2.4 are shorted, the external output switch is closed
		2.4	GND	2.3 and 2.4 have been shorted in factory

3.2.3 BCB Port

J4 is the BCB port. The port is shown in Figure 3-9 and described in Table 3-6.

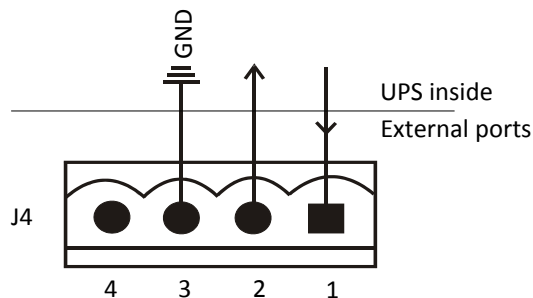

Figure 3-9 BCB port J4

Table 3-6 Description of BCB port J4

Silkscreen	Port	Pin No.	Pin name	Meanings
------------	------	---------	----------	----------

Silkscreen	Port	Pin No.	Pin name	Meanings
J4	BCB	4.1	DRV	BCB undervoltage release. Normally 12V, tripping at 0V
		4.2	FB	BCB backfeeding signal input (normally open). Normally open auxiliary contact signal of BCB: Auxiliary contact closed upon circuit breaker closed, while auxiliary contact open upon circuit breaker open
		4.3	GND	GND

3.2.4 Backfeed Protection Dry Contact Port

The backfeed protection dry contact port J5 is shown in Figure 3-10 and described in Table 3-7. The rated capacity of the backfeed protection dry contact is 240Vac/24Vdc, 5A.



Warning

The voltage of the dry contact signal connected to J5 backfeed protection dry contact port may be dangerous. Before connection, make sure that you are connecting the cable to the right port.

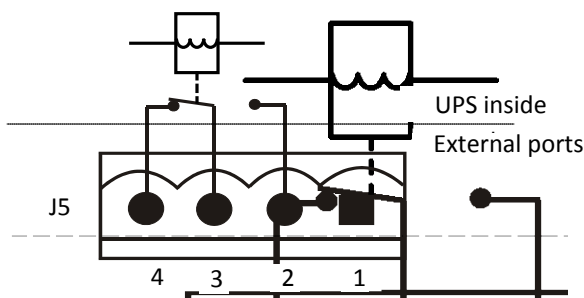

Figure 3-10 Backfeed protection dry contact port J5

Table 3-7 Description of backfeed protection dry contact port J5

Silkscreen	Port	Pin No.	Pin name	Meanings
J5	Rectifier/Bypass backfeed output	5.2	BFP_O	Rectifier/bypass backfeed normally open contact. Open when there is no backfeed
		5.3	BFP_S	Rectifier/bypass backfeed common contact
		5.4	BFP_C	Rectifier/bypass backfeed normally closed contact. Closed when there is no backfeed

3.2.5 Remote EPO Input Port

The UPS has an EPO function that operates by an EPO button on the operator control and display panel of the UPS or by a remote contact provided by the user. The EPO switch has a protective cover.

J3 is the remote EPO input port. The port is shown in Figure 3-11 and described in Table 3-8.

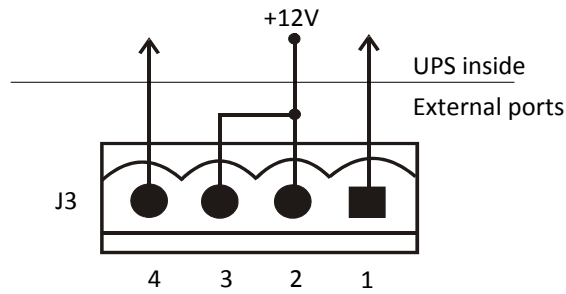

Figure 3-11 Remote EOP input port J3

Table 3-8 Description of remote EPO input port

Silkscreen	Port	Pin No.	Pin name	Meanings
J3	Remote EPO input	3.1	EPO_NC	EPO activated when opened to 3.2. Pins 3.1 and 3.2 have been shorted in factory
		3.2	+12V	EPO activated when opened to 3.1
		3.3	+12V	EPO activated when shorted to 3.4
		3.4	EPO_NO	EPO activated when shorted to 3.3

EPO is triggered when pins 3 and 4 of J3 are shorted or pins 2 and 1 of J3 are opened.

If an external EPO facility is required, pins 1 and 2 or 3 and 4 of J3 are reserved for this function. The external EPO facility is also connected to the normally open or normally closed remote EPO switch between these two terminals using shielded cable. If this function is not used, pins 3 and 4 of J3 must be opened and pins 1 and 2 of J3 must be shorted.



Note

The UPS EPO action shuts down the rectifier, inverter and static bypass, but it does not internally disconnect the mains input power. To disconnect all power to the UPS, open the external power switch, bypass input switch, output switch and BCB after EPO is activated.

3.2.6 RS232 Communication Port

See Figure 3-7 for the position of RS232 port. RS232 port monitors and sets parameters through connecting with computer.

The RS232 port provides serial data and is intended for use by authorized commissioning and service personnel in UPS commissioning and service.

3.2.7 USB Communication Port

The position of the USB port is shown in Figure 3-7.

The USB port can connect the monitoring software.

The methods to connect the communication cable are as follows:

Insert one end of the USB communication cable to the USB port (see Figure 3-7) on the UPS, and connect the other end to the USB port of the computer.

After the connection, you need to install the USB drive program in the installation disk.

Note: To make the communication normal, do not connect the RS232 port and USB port to the computer at the same time.

3.2.8 Parallel And LBS Communication Ports

See Figure 3-7 for their positions.

3.2.9 RS485 Communication Port

See Figure 3-7 for its position. See Table 3-9 for definition of its pins, and see Figure 3-12 for the cable connection diagram of RS485 communication port.

Table 3-9 Pins definition of RS485 communication port

Pin	1, 2	3, 6	4, 5	7	8
Definition	NC	NC	GND	D+	D-

Connect to monitoring host

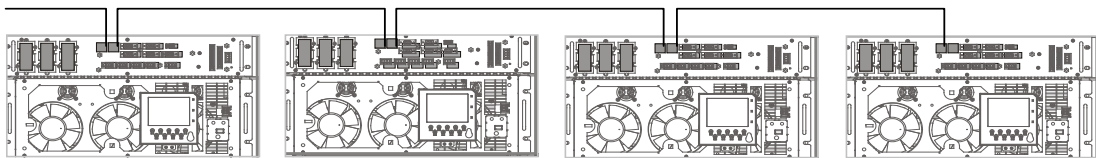

Figure 3-12 Cable connection diagram of RS485 communication port

3.2.10 Intellislot Port

The Intellislot ports are used for installing optional cards on the site, including IS-Relay card, IS-485L card, IS-WEBL card. Table 3-10 provides the models and installation positions of the optional cards. For the detailed installation of the optional cards, refer to the corresponding contents in *Chapter 8 Options*.

Table 3-10 Models and installation positions of optional cards

Optional card	Installation position
IS-Relay card	Intellislot ports 1 and 3 (Intellislot port 1 recommended)
IS-485L card	Intellislot ports 1 and 3 (Intellislot port 3 recommended)
IS-WEBL card	Intellislot ports 1 ~ 3 (Intellislot port 2 recommended)



Note

1. The Intellislot port 2 shares communication resource with RS485 port. To avoid conflict, when using RS485 port in service and commissioning, it is not recommended to use the Intellislot port 2.
2. The Intellislot port 3 shares communication resource with RS232 and USB ports. To avoid conflict, when using RS232 and USB ports in service and commissioning, it is not recommended to use the Intellislot port 3.

3.2.11 Signal Cable Connection Steps



Note

Respectively route the power cables and signal cables. The shielding coat of signal cable must be reliably earthed.

Two connection modes are available: top cable access, bottom cable access. See Figure 3-13 and Figure 3-14.

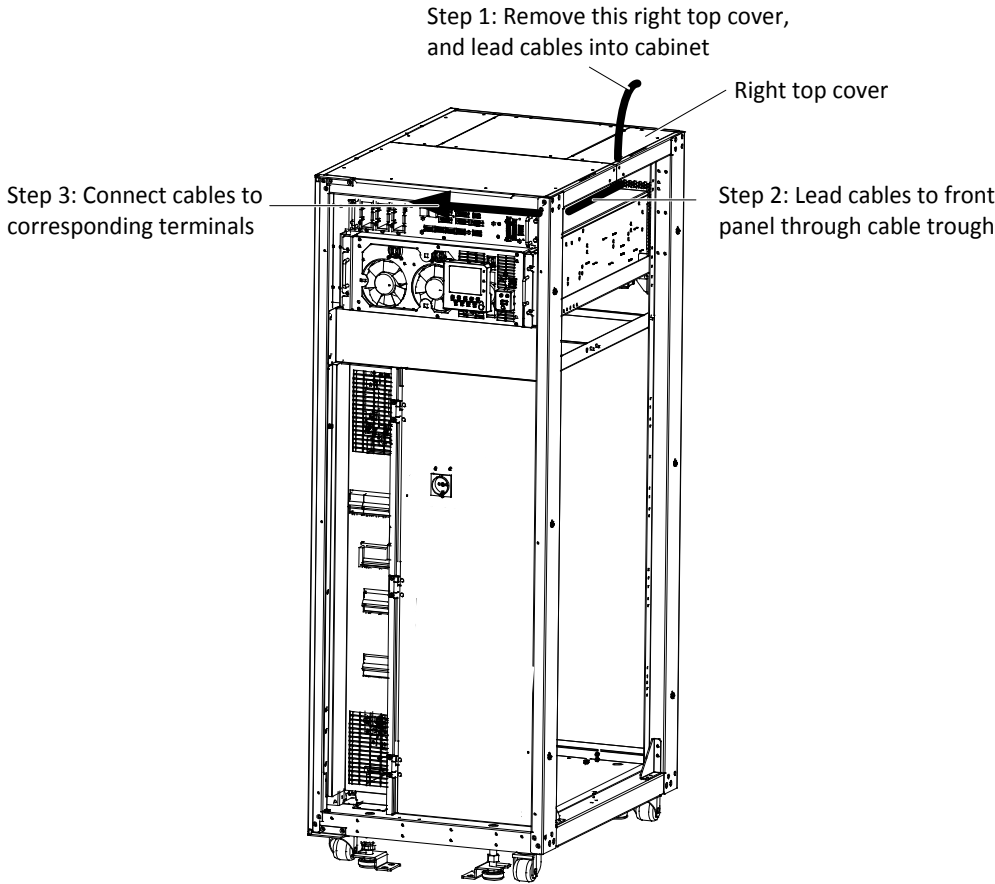

Figure 3-13 Signal cables wiring route (top cable access)

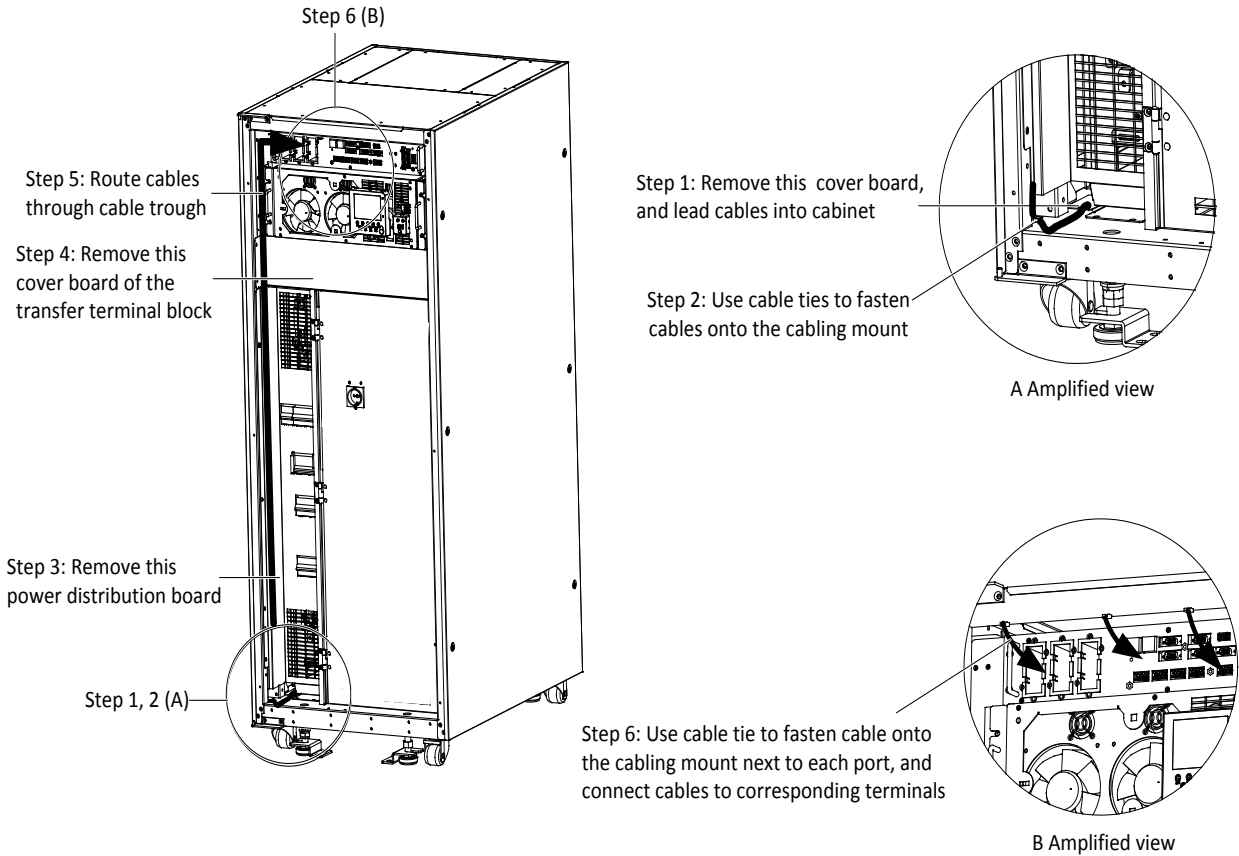

Figure 3-14 Signal cables wiring route (bottom cable access)

Chapter 4 Operator Control And Display Panel

This chapter expounds the functions and use of the components on the operator control and display panel of the UPS, provides LCD display information, including the LCD screen types, detailed menu messages, prompt windows and UPS alarm list.

4.1 Introduction

The UPS front provides the operator control and display panel. It is the access point for operator control and query all measured parameters, UPS and battery status and alarms.

The operator control and display panel is divided into three functional areas: LCD screen, LED indicator and control keys, as shown in Figure 4-1, and as described in Table 4-1.



Figure 4-1 Operator control and display panel

Table 4-1 Description of components of the operator control and display panel

No.	Function	Key	Function
1	Alarm indicator (Red)	F1 ~ F5	LCD menu keys
2	Inverter indicator (Green)	FAULT CLEAR	Fault reset switch
		ON	Inverter start switch
		OFF	Inverter shutdown switch
		ALARM CLEAR	Alarm silencing switch
		EPO	EPO switch

4.1.1 LED Indicators

The two indicators show the current working state of the UPS, see Table 4-2 for details.

Table 4-2 Definition of indicators

Indicator	Status	Description
Inverter indicator	Solid green	Load powered by the inverter
	Flashing green	Inverter turning on, starting up, synchronizing or in stand-by state (ECO mode)
	Off	Inverter off
Alarm indicator	Solid red	Rectifier not ready or critical fault (fro example, inverter relay short circuit, bypass STS short circuit, bypass backfeed and inverter fault, etc.)

Indicator	Status	Description
	Flashing red	General fault (for example, module overload, battery disconnected, fan failure and parallel load sharing failure, etc.)
	Off	No fault

4.1.2 Audible Alarm (Buzzer)

UPS activity is accompanied by the two kinds of sound listed in Table 4-3.

Table 4-3 Description of audible alarm

Alarm sound	Meaning
Beep every other second	Alarm upon a general fault, for example, module overload, battery disconnected, fan failure, parallel load sharing failure and battery discharge pre-alarm, etc.
Continuous beep	Alarm upon a general fault, for example, inverter relay short circuit, bypass STS short circuit, bypass backfeed and inverter fault, etc.

4.1.3 Control Keys

The operator control and display panel provides five control keys, as described in Table 4-4.

Table 4-4 Description of control keys

Control key	Silkscreen	Description
EPO switch	EPO	Cut off the load power and battery, shut down the rectifier, inverter, static bypass
Inverter start switch	ON	Start the inverter
Inverter shutdown switch	OFF	Shut down the inverter
Fault reset switch	FAULT CLEAR	Clear fault to restart the UPS
Alarm silencing switch	ALARM CLEAR	When an alarm is active, pressing this key silences the audible alarm. Pressing this key again enables the buzzer again



Note

It is required to hold and press the preceding keys for 2s to initiate the key function.

4.1.4 LCD And Menu Keys

The operator control and display panel provides an LCD screen and five menu keys (F1 ~ F5). The menu keys are described in Table 4-5.

Table 4-5 Description of menu keys

Key	F1	F2	F3	F4	F5
Function 1	HOME	ESC Escape	Left	Right	Enter
Function 2			Up	Down	

Providing 320 × 240 dot matrix graphic display, the user-friendly and menu-driven LCD allows you to easily browse through the input, output, load and battery parameters of the UPS, get current UPS status and alarm information, and perform functional setting and control operation. The LCD also stores up to 2048 historical records that can retrieve for reference and diagnosis.

4.2 LCD Screen Type

4.2.1 Start Screen

Upon UPS start, the UPS executes self-test, and the start screen appears and remains approximately 25 seconds, as shown in Figure 4-2.



Figure 4-2 Start screen

4.2.2 Primary Screen

After the UPS starts and finishes self-test, the primary screen appears, as shown in Figure 4-3. The primary screen is divided into four windows: system information window, data window, menu window and keypad window.

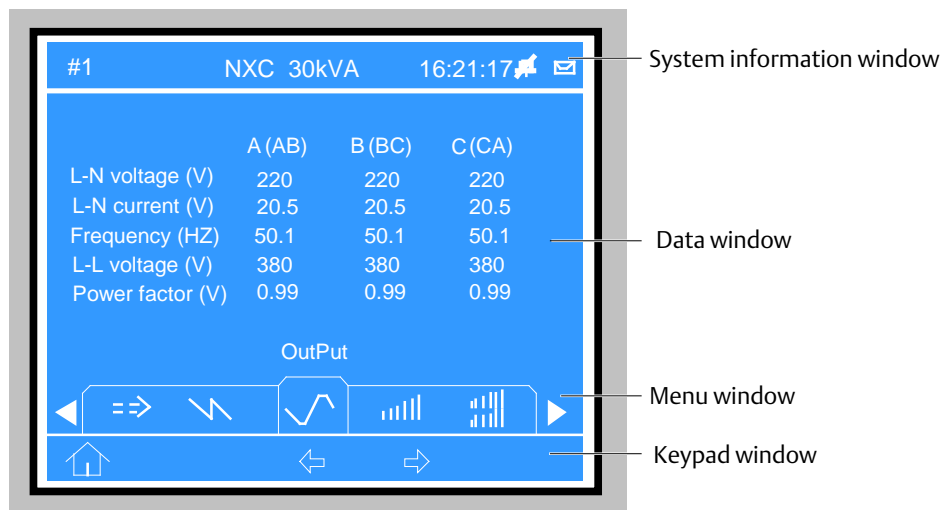

Figure 4-3 Primary screen

The functions of the menu keys F1 ~ F5 for the current screen are shown by self-explanatory icons in the keypad window as appropriate. From any menu on the primary screen, pressing the F1 key returns to the 'OutPut' menu.

4.2.3 Default Screen

During UPS operation, if there is no alarm or key action within two minutes, the default screen will appear, as shown in Figure 4-4. After a short delay, the LCD backlight will turn off. Pressing any menu keys (F1 ~ F5) restores the default screen.



Figure 4-4 Default screen





4.3 Detailed Description Of Menu Items

The description that follows refers to the LCD primary screen shown in Figure 4-3.

System information window

The system information window displays the current time, UPS name, configuration and alarm silencing state. This window requires no user operation. For details, see Table 4-6.

Table 4-6 Item description of system information window

Item	Explanation
NXC	UPS series name
(Configuration) Single/ECO/Unit1#	Single: UPS module system with dual conversion ECO: The UPS is set as a UPS module system, and runs in ECO mode Unit1#: #1 of the parallel system formed by up to four UPS modules
30kVA	UPS power is 30kVA
16:21:17	Current time (format: 24 hours, hour: minute: second)
 	Audible alarm enabled or disabled.  : disabled,  : enabled

Menu window and data window

The menu window provides the menus of the data window. The data window displays the items of the menu selected in the menu window. UPS parameters can be browsed and functions can be set through the menu window and data window. Details are provided in Table 4-7.

Table 4-7 Item description of menu window and data window

Menu	Item	Explanation
Mains	L-N voltage (V)	Phase voltage
	L-N current (A)	Phase current
	Frequency (Hz)	Input frequency
	L-L voltage (V)	Line voltage
	Power factor	Power factor
Bypass	L-N voltage (V)	Phase voltage
	Frequency (Hz)	Bypass frequency
	L-L voltage (V)	Line voltage
OutPut	L-N voltage (V)	Phase voltage
	L-N current (A)	Phase current
	Frequency (Hz)	Output frequency
	L-L voltage (V)	Line voltage
	Power factor	Power factor
Load	Sout (kVA)	Sout: apparent power
	Pout (kW)	Pout: active power
	Qout (kVAR)	Qout: reactive power
	Load level (%)	Load (expressed in percentage of the UPS rating load)
	Crest factor	Output current crest factor
System	Sout (kVA)	Sout: apparent power
	Pout (kW)	Pout: active power
	Qout (kVAR)	Qout: reactive power
	Single unit, no parallel system data	Displayed on this data window when the UPS is configured as a single unit
Battery	Battery voltage (V)	Battery bus voltage
	Battery current (A)	Battery bus current
	Battery temperature (°C)	Built-in battery temperature
	Battery remain time (Min.)	Remaining battery backup time
	Battery capacity (%)	Percentage of battery life when compared to a new battery
	Battery boost charging	Battery is boost charging
	Battery float charging	Battery is float charging
	Battery is not connected	Battery is not connected
Event	(active alarm)	Display the active alarms
Records	(alarm history)	Display the alarm history
Language	(language option)	Provide 17 optional LCD languages

Menu	Item	Explanation
Settings	Display contrast	Adjust the LCD contrast
	Date format set	Three formats selectable: MM/DD/YYYY, DD/MM/YYYY, YYYY/MM/DD
	Date & time	Set the date and time
	Comm1 baud rate	Set the communication baud rate of the Intellislot port 1
	Comm2 baud rate	Set the communication baud rate of the Intellislot port 2
	Comm3 baud rate	Set the communication baud rate of the Intellislot port 3
	Communication address	Applicable to RS485 communication
	Single Group Batt Cap	Set the capacity of battery unit
	Battery Cells Number	Set the battery cells connected to the UPS
	Equalize Charge Allowed	Battery boost charge is enabled or not
	Temp Compensation	Enabled, Disabled
	Shared Battery	Enabled, Disabled
	System Configuration	Single, Parallel
	Parallel Requisite units	Basic number of single modules in parallel system
	Parallel Redundant units	Redundant number of single modules in parallel system
	Parallel ID	Provide one ID code for single module in parallel system, when 'Parallel' is set
	ECO Mode	Normal, ECO
	Output Frequency Level	Set the system output frequency (unit: Hz); 50/60
	Output Voltage Level	The voltage between phase line and phase line
	LBS Function	NONE, SLAVE, MASTER
Command password	The user can modify the command password	
Protocol	YDN23, Velocity	
Command (initiate, stop battery, system test or freshening charge)	Battery maintenance test	20% battery capacity is out upon battery maintenance test. Load must be between 20% and 80%
	Battery capacity test	Perform a full discharge of the battery to obtain a precise measure of the battery capacity. Load must be between 20% and 80%
	System test	Self-test of the UPS. When the user activates this function, a window appears about 5s later to show the test result
	Stop testing	Manually stop a battery maintenance test, battery capacity test or system test
	Freshening charge	Manually initiate a battery freshening charge
	Stop freshening charge	Manually stop a battery freshening charge
Eff.Curve	Eff.Curve	Display the system efficiency at current load
Run Time	UPS Run time	Display UPS accumulated run time
	Byp. Run time	Display UPS accumulated run time on bypass
Version	UPS version	Provide UPS inverter, rectifier and monitoring software versions
	UPS model	Provide UPS model information, for example, 208V-60Hz

Keypad window

The functions of the menu keys (F1 ~ F5) for the current screen are shown by self-explanatory icons in the keypad window as appropriate.

4.4 Prompt Window

A prompt window is displayed during the operation of the system to alert you to certain conditions or to require your confirmation of a command. The prompts are provided in Table 4-8.

Table 4-8 Prompts and meanings

Prompt	Meaning
Transfer with interrupt, confirm or cancel	The load executes interval transfer between the inverter and bypass
The load is too high to be transferred with interrupt	The total load must be less than the capacity of one UPS to allow a parallel system to perform an interrupted transfer from bypass to inverter
This operation leads to output shutdown, confirm or cancel	The bypass is abnormal, turning off the inverter will cause the load to be disenergized
This operation leads to inverter overload, confirm or cancel	Turning off this inverter will lead to the overload of the remaining inverter(s) in a parallel system
Turn on more UPS to carry current load	The number of inverters already turned on is insufficient to carry the existing load. The user is required to turn on more UPSs
Battery will be depleted, confirm or cancel	If you select battery maintenance test, the battery will discharge until the UPS shuts down. This prompt appears to require your confirmation. Canceling the test will end the test and transfers the UPS to inverter mode
System self test finished, everything is OK	No action required
Please check the current warnings	Check the active alarm messages
Enter control password	Required for battery or UPS test (default: 12345)
Battery Self Test aborted, conditions not met	Battery self-test condition is not met. Please check if the battery is in boost charge state and the load is more than 20%
Battery Refresh Charge aborted, conditions not met	This prompt appears when you select the Freshening charge command while the a battery freshening charge condition (such as no battery, charger failure) is not met
Please check cable connection, turn off UPS totally, Three Phase Output, Single Phase Output	After the menu '3 Phase Output or 1 Phase Output' is set, you can power off the system completely, and then power on the system again after the wiring is changed according to the settings

4.5 Alarm List

Table 4-9 provides the complete list of UPS alarm messages for display either on the 'Event' menu or on the 'Records' menu described in Table 4-7.

Table 4-9 UPS alarm list

Alarm	Explanation
Fault reset	FAULT CLEAR key on the operator control and display panel pressed
Rectifier in setting	The rectifier starts up and is in synchronization
Inverter in setting	The inverter starts up and is in synchronization
Manual turn on	ON key on the operator control and display panel pressed to turn on the inverter
Manual turn off	OFF key on the operator control and display panel pressed to turn off the inverter

Alarm	Explanation
Turn on fail	The inverter failed to turn on when the ON key is pressed. This may be the result of an invalid operation (maintenance bypass switch closed) or DC bus or rectifier not ready
Soft start fail	Owing to low DC bus voltage, the rectifier will report this alarm
Alarm silence	ALARM CLEAR key on the operator control and display panel pressed
Audible alarm reset	ALARM CLEAR key on the operator control and display panel pressed in alarm silence state
Bypass mode	The UPS is in bypass mode
Normal mode	The UPS is in normal mode
Battery mode	The UPS is in battery mode
UPS shutdown	UPS shutdown with no output power
Output disabled	EOD event happened. Check the battery voltage
System Bypass STS fail	The adjacentbypass STS open circuit fault or short-circuit fault
Mains volt. abnormal	The mains voltage is outside specifications and results in rectifier shutdown
Mains undervoltage	At least one phase main input voltage is within 132V ~ 176V, thus the load should be derated
Mains freq. abnormal	The mains frequency is outside specifications and results in rectifier shutdown
Mains phase reversed	The AC input phase rotation is reversed
Input feedback	Battery voltage fed back to rectifier input
Mains neutral lost	AC rectifier input neutral line not detected
Input current abnormal	Battery load sharing imbalance or rectifier input current abnormal
Input curr. over limit	Input current over limit
Bypass unable to trace	The bypass frequency is outside specifications. This alarm automatically resets once the bypass voltage goes normal
Bypass abnormal	The amplitude or frequency of the bypass voltage exceeds the limit. This alarm automatically resets once the bypass voltage returns to normal. Or this fault is caused by incorrect connection of 3-in 1-out mode
Bypass STS fail	At least one of the STSs at the bypass side is open or shorted. This fault is locked until power-off
By. abnormal shutdown	Both the bypass and inverter voltages are abnormal, and the output is off
Bypass phase reversed	The phase rotation of the bypass voltage is reversed
Bypass overcurrent	The bypass current is outside the rated current
Rectifier fault	Bus voltage abnormal or battery SCR short circuit
Rectifier overtem	The temperature of the rectifier radiator is so high that the inverter cannot operate normally
DC bus over voltage	The rectifier, inverter and battery converter shut down because the DC bus voltage is too high. The load transfers to bypass
DC bus abnormal	The DC bus voltage is abnormal and results in inverter shutdown. The load transfers to bypass
Inverter asynchronous	The output voltage and bypass voltage are misaligned in phase. This alarm resets automatically once the condition is no longer true
Inverter fault	Inverter output voltage outside specifications. Load transfers to bypass
Inverter relay fail	At least one of the inverter relays is opened or shorted. This fault is locked until mains power-off
Output fuse fail	At least one of the inverter output fuses is blown
Output volt. abnormal	At least one phase of the output voltages is abnormal
Unit overload	This alarm appears when the load rises above 105% of the nominal rating. The alarm automatically resets once the overload condition is removed

Alarm	Explanation
System overload	This alarm appears when the total load rises above 105% of the nominal rating of the parallel system. The alarm automatically resets once the overload condition is removed
Unit overload timeout	The UPS overload status continues and the overload times out. When the time has expired, the load automatically transfers to the bypass
Load impact transfer	A transfer to bypass occurred due to a large step load. The UPS can recover automatically. Turn on the load equipment in stages to reduce the load impact on the inverter
Transfer time-out	The load remains on bypass power owing to excessive number of transfers that occurred within the one hour
Load sharing abnormal	The UPSs in a parallel system are not sharing the load current correctly
System transfer	All UPSs in the parallel system transfer to bypass at the same time when one of them needs to transfer to bypass. This message appears on the LCD of the UPS with passive transfer to bypass
Control power fail	The auxiliary power failure or power-off
EPO	EPO button on operator control and display panel pressed or external EPO command received
Fan abnormal	At least one fan has fault
Operation invalid	Maintenance bypass switch is closed when the parallel system is on inverter, or output switch and maintenance bypass switch are closed when the inverter is on
LBS active	The LBS setting is active
LBS abnormal	LBS is abnormal
Maint. sw. open	Maintenance bypass switch is open
Maint. sw. closed	Maintenance bypass switch is closed
Output sw. closed	Output switch is closed
Output sw. open	Output switch is open
Charger fault	Battery charger has failure
Dischg. curr. limit	Discharge current is over limit, close the discharger
Auto start	After UPS shutdown at EOD, the inverter automatically starts upon mains restoration
Freshening boost charge	The battery is forced to be in boost charge state
Rec flash update	Rectifier software being updated
Inv flash update	Inverter software being updated
Monitor flash update	Monitoring software being updated
FLASH operate fail	Historical record not saved
Remote turn ON	Turn on the inverter through the service command
Remote turn ON failed	Caused by invalid operation (maintenance bypass switch closed), DC bus or rectifier not ready
Remote turn OFF	Turn off the inverter through the service command
Load sharing abnormal	Each UPS module in parallel system cannot execute load sharing
Communication fail	Interruption in communication between internal monitoring board and inverter, rectifier
Parallel comm. fail	Communication between the UPS modules of a parallel system failed. Check if any UPS modules in the parallel system are not on; if yes, power on these UPSs and then check if the alarm disappears
No battery	Check the battery and battery connection
Batt. converter fault	Bus voltage abnormal
Battery reverse	Reconnect battery and check battery wiring
Battery period testing	The battery is under automatic periodic battery maintenance test (20% capacity discharge)
Batt. capacity testing	The user initiated a battery capacity test (100% capacity discharge)
Battery maintenance	The user initiated a maintenance test (20% capacity discharge)

Alarm	Explanation
testing	
Battery end of discharge	Inverter turned off due to battery EOD
Battery overtemp.	The battery temperature is over limit
Battery low pre-warning	Before the EOD, battery low pre-warning will occur. After this pre-warning, the battery will have the capacity for 3min discharging with full load. The time is user-settable from 3min to 6min
Generator in	Dry contact signal, indicating generator connected
BCB status abnormal	Logic conflict between BCB drive signal and feedback signal
BCB closed	BCB state (closed)
BCB open	BCB state (open)
Output TX Overtemp	The output isolation transformer has over temperature fault

**Note**

1. For UPS installed with the optional battery monitor, refer to the user manual of the battery monitor for the alarm messages related to battery cell and charge current.
2. If the alarm is caused through setting the software value by Vertiv authorized engineer, and you wish to change the setting values, please contact the Vertiv local customer service center.

Chapter 5 UPS Operation Introduction

This chapter introduces the operating precautions and daily operating methods of UPS in detail.

5.1 Brief Introduction

5.1.1 Precautions



Important

The user can conduct relative operation only after the authorized engineer carries out the first power on and test.



Warning: hazardous mains and/or battery voltage

1. The components that can only be accessed by opening the protective cover with tools cannot be operated by the user. Only qualified service personnel are authorized to remove such covers.
2. The AC input and output terminals of UPS have dangerous voltage at any time. If the cabinet is equipped with an EMC filter, the filter may have dangerous voltage.

1. For the control keys and LCD related to all the operating steps, refer to *Chapter 4 Operator Control And Display Panel*.
2. During operation, the buzzer alarm may occur at any time. Press ALARM CLEAR key to silence the audible alarm.
3. When UPS uses traditional lead-acid battery, the system provides boost charge optional function. If the lead-acid battery is used, when the mains returns after an extended mains failure, the charging voltage of the battery will be higher than the normal charging voltage, this is normal, and the charging voltage of the battery will return to normal value after a few hours' charging.

5.1.2 Power Switch

Opening the front door of the UPS cabinet reveals the power switches, as shown in Figure 5-1, including:

Q1: Rectifier input switch, which connects UPS to the main circuit power.

Q2: Bypass input switch, which connects UPS to the bypass.

Q3: Maintenance bypass switch (locked), which supplies power to the load when UPS is being maintained.

Note: If the UPS system is composed of more than 2 paralleled UPS modules, do not use the internal maintenance bypass switch.

Q5: Output switch, which connects UPS output to the load.

Q6: Neutral line switch (locked)

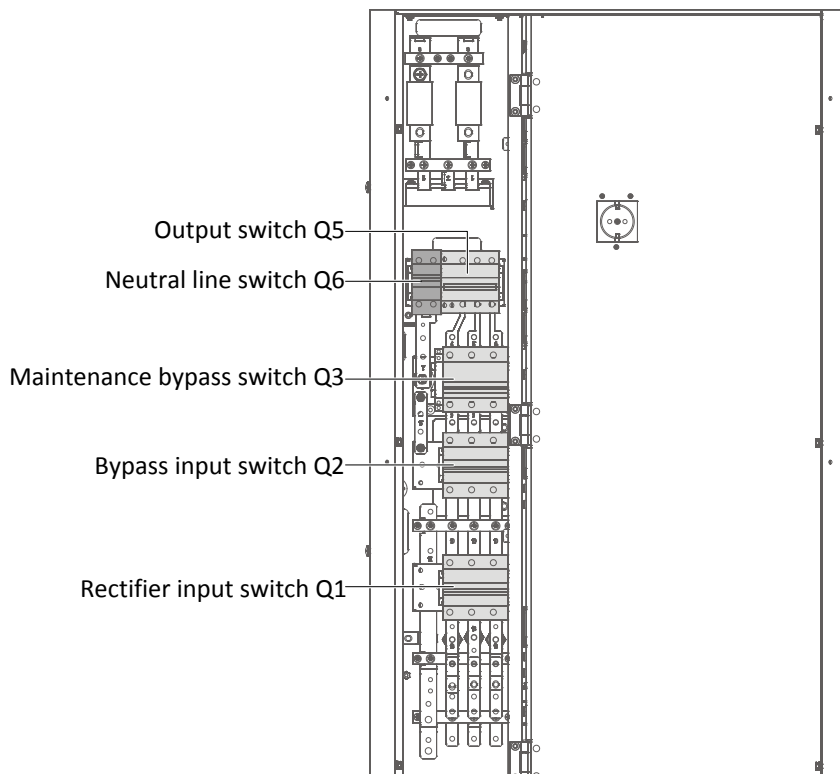

Figure 5-1 UPS power switch

5.2 UPS Startup Procedures

The UPS must be completely installed and tested by authorized engineer, and external power supply switch is closed, then you can start the UPS.

According to the system actual configuration, the authorized engineer can set '3-phase out/single-phase output' to '3-phase (factory default)' or 'single-phase'.

5.2.1 Startup Procedures In Normal Mode



Warning

1. These procedures result in mains voltage being applied to the UPS output terminals.
2. If any load equipment is connected to the UPS output terminals, check with the user that it is safe to apply power. If the load is not ready to receive power, please disconnect the downstream load switch, and stick a warning label on the connection point of the load.

Use the following procedures to turn on the UPS from a fully powered down condition.

1. Open the front door of the UPS, ensure that the internal maintenance bypass switch Q3 is disconnected and switch Q6 is closed, while the input cables and copper bars are reliably connected.



Warning

All operations relating to disconnect or close the maintenance bypass switch shall be finished within three seconds, to avoid misreporting as faults.

2. Close the bypass input switch Q2, rectifier input switch Q1, output switch Q5 and all external output isolating switches (if any) of the UPS in turn.

At the moment, the system is powered on, and the startup screen pops up. Refer to 4.2.1 Start Screen.

About 25 seconds later, confirm that the LCD shows the rectifier power supply and the bypass power supply are normal; if not, check whether the switches Q1 and Q2 are closed. Then the rectifier starts up and the alarm indicator (red) is on. At the same time, the bypass static switch is closed. About 30 seconds later, the alarm indicator (red) is flashing, and then the rectifier startup is finished.

3. Press the ON key for two seconds.

The inverter starts up, and the inverter indicator (green) is flashing. After the inverter runs normally, the UPS transfers from the bypass to inverter, then the inverter indicator (green) is on.

5.2.2 Startup Procedures In ECO Mode

1. Open the front door of the UPS, ensure that the internal maintenance bypass switch Q3 is disconnected and switch Q6 is closed, while the input cables and copper bars are reliably connected.



Warning

All operations relating to disconnect or close the maintenance bypass switch shall be finished within three seconds, to avoid misreporting as faults.

2. Close the bypass input switch Q2, rectifier input switch Q1, output switch Q5 and all external output isolating switches (if any) of the UPS in turn.

At the moment, the system is powered on, and the startup screen pops up. Refer to 4.2.1 *Start Screen*.

About 25 seconds later, confirm that the LCD shows the rectifier power supply and the bypass power supply are normal; if not, check whether the switches Q1 and Q2 are closed. Then the rectifier starts up and the alarm indicator (red) is on. At the same time, the bypass static switch is closed. About 30 seconds later, the alarm indicator (red) is flashing, then the rectifier startup is finished.

3. Press the ON key for two seconds.

The inverter starts up, and the inverter indicator (green) is flashing. At this time, the UPS is in ECO mode, and powered by the bypass.

UPS operated in ECO mode

5.2.3 Startup Procedures In Battery Mode (Battery Cold Start)

Note: The startup function of battery mode is only applicable to the UPS equipped with internal battery.

1. Verify that the battery has been connected, and that the battery voltage is transferred to the input terminal of the battery.

2. Open the front door, and press the battery cold start button (see Figure 5-2 for its position).

At the moment, the startup screen pops up. Refer to 4.2.1 *Start Screen*.

About 25 seconds later, the rectifier starts up and the alarm indicator (red) is on. About 30 seconds later, the alarm indicator (red) is flashing, and then the rectifier startup is finished.

3. Press the ON key for two seconds.

The inverter starts up, and the inverter indicator (green) is flashing. After the inverter runs normally, the inverter indicator (green) is on. At this time, the UPS is powered by the inverter.

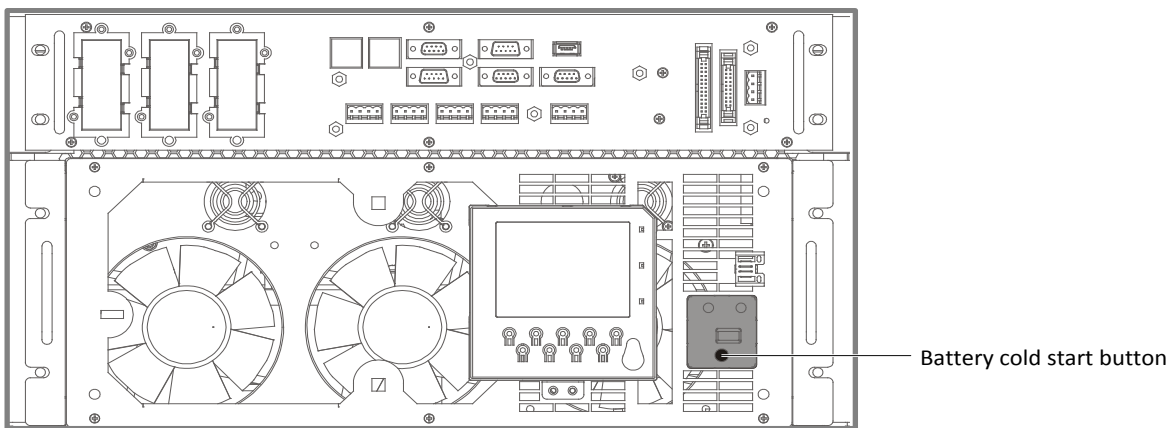

Figure 5-2 Battery cold start button

5.3 Procedures For Transfer Between Operation Modes

5.3.1 Transfer From Normal Mode To Battery Mode

Open the external power switch to isolate the mains power and initiate the UPS on battery mode. To transfer the UPS back to normal mode, wait for several seconds, and then close the external power switch to re-connect the mains power to the UPS. 10 seconds later, the rectifier restarts automatically, and the UPS works in normal mode.

5.3.2 Transfer From Normal Mode To Bypass Mode

Press the OFF key for two seconds, the inverter indicator (green) is off, and the UPS will be transferred from normal mode to bypass mode.

	Note
In bypass mode, the load is directly fed by the mains power instead of the pure AC power from the inverter.	

5.3.3 Transfer From Bypass Mode To Normal Mode

When the UPS is in bypass mode, press the ON key for two seconds, the inverter starts up, and the inverter indicator (green) is flashing till the inverter enters normal operation, then the UPS is transferred from bypass mode to normal mode.

5.3.4 Transfer From Normal Mode To Maintenance Mode

The following procedures will transfer the UPS from inverter output mode to the maintenance bypass mode.

	Caution: power supply interruption danger of the load
Before making this operation, read the information on the LCD to make sure that the bypass supply is normal and that the inverter is synchronous with the bypass supply, so as not to risk a short interruption in power to the load.	

1. Press the OFF key at least two seconds. At this point, the inverter indicator (green) turns off, accompanied by an audible alarm. The load transfers to the static bypass, and the inverter shuts down.

	Note
---	-------------

Pressing the ALARM CLEAR key cancels the audible alarm but leaves the alarm message displayed until the alarm condition is rectified.

2. Close the maintenance bypass switch Q3 when the UPS is in single module mode.
3. At the moment, the maintenance bypass parallels with the UPS static bypass.
4. The LCD displays 'Maint. sw. closed'.
5. Disconnect the output switch Q5 and neutral line switch Q6.

At the moment, the load is powered by the maintenance bypass directly.



Caution

When the UPS is in maintenance mode, the load is not protected against abnormal mains supply.

6. Pressing the EPO button stops the operation of rectifier, inverter, static switch and battery, but this action will not affect the maintenance bypass power the load normally.



Note

In maintenance mode, the load is directly fed by the mains power instead of the pure AC power from the inverter.

7. If the UPS has internal battery, use the special tool to open the battery compartment door, then wear arc preventive gloves to disconnect the three terminals 'BAT+', 'BAT-' and 'BAT N' (see Figure 5-3 for details). If the UPS has external battery, disconnect the corresponding switch of the external battery.

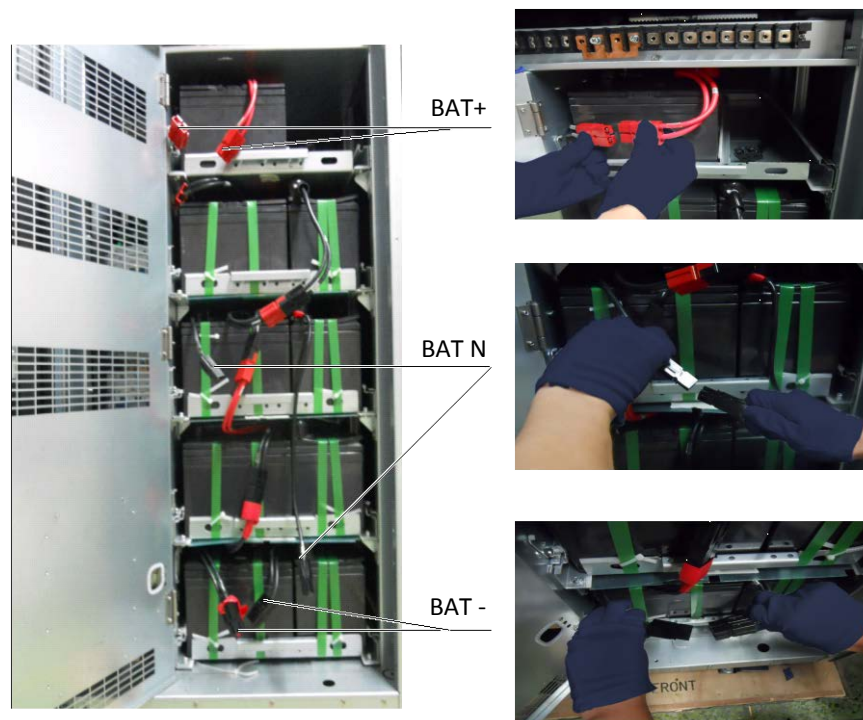

Figure 5-3 Disconnecting terminals of the internal battery

8. Disconnect the rectifier input switch Q1 and bypass input switch Q2.

At the moment, all the internal power supply is closed and the LCD does not display any more.



Warning

1. If the maintenance is required, wait 10 minutes for the internal DC bus capacitance discharging.
2. The parts of UPS circuits also have hazardous voltage, though the rectifier input switch, bypass input switch and

battery switch are disconnected. Therefore, the UPS maintenance is suitable for qualified personnel only.

5.3.5 Transfer From Maintenance Mode To Normal Mode

The following procedures will transfer the maintenance bypass supply mode of the UPS to the normal mode.

1. Open the front door, close the neutral line switch Q6.
2. Close the output switch Q5.
3. Close the bypass input switch Q2.
4. After the LCD startup, the system will transfer to the Event menu window till the system confirms that the record displays 'Bypass mode'.



Warning

You must start the bypass first, and then disconnect the maintenance bypass switch; or it will cause output load power failure.

5. Disconnect the internal maintenance bypass switch Q3.
6. Close the rectifier input switch Q1, then the alarm indicator (red) is flashing.
7. Press the ON key for two seconds.

The inverter starts up, and the inverter indicator (green) is flashing. After the inverter runs normally, the UPS will be transferred from the bypass to inverter, and then the inverter indicator (green) is on.

At the moment, the load has transferred to UPS normal mode.

5.4 Battery Test Procedures

The battery test function is disabled by default. If you need this function, please contact the customer service engineer of Emerson.

Battery test type and preconditions

1. There are two battery tests to select from:
 - Battery maintenance test: verifies the battery integrity and leads to the battery being partly discharged (20%).
 - Battery capacity test: verifies precisely the battery capacity and leads to the battery being fully discharged (until Battery low pre-warning alarm)
2. The tests can be carried out from the operator control and display panel of the UPS by the operator when the following conditions are satisfied:
 - The load must be greater than 5% of rated UPS capacity and must be stable (for battery maintenance test)
 - The load must be between 20% and 80% of rated UPS capacity and must be stable (for battery capacity test)
 - The battery must have been float charging for 5 hours or more before battery capacity test

The battery test procedures are password controlled and menu driven. The test is immediately terminated in the event of a battery or a mains failure and the total load power is supported from the remaining source without interruptions.

Test procedure

1. Select the Command menu on the LCD screen on the operator control and display panel of the UPS. Use the right or left key to navigate to the Command menu.

2. Select the desired test (the Battery maintenance test or Battery capacity test option).

Use the up and down keys (F3, F4) to highlight the desired test. Press the Enter key (F5).

When prompted, enter each password digit with up key (F3) and use right key (F4) to access next field. Press the Enter key (F5) when all digits have been entered.

3. Wait until the test completes.

This test updates the battery information, including the battery autonomy time (battery discharge duration during AC input failure) and the battery aging coefficient (battery capacity percentage when compared to a new battery).

4. Stop the test.

If required, the test may be stopped before completion by selecting Stop testing on the Command menu.

5.5 UPS Self-test Procedures

During the self-test, the UPS can check the UPS control functions, LED indicators and audible alarm states. This self-test is password controlled and menu driven. It can be carried out from the UPS operator control and display panel by the operator and takes five minutes.

Procedures for UPS self-test

1. Select the Command menu on the LCD screen on the operator control and display panel of the UPS.

Use the left key (F3) or right key (F4) to display the Command menu. Press the Enter key (F5) to confirm it.

2. Select the desired test.

Use the up key (F3) or down key (F4) to highlight the desired test item. Press the Enter key (F5) to confirm it.

After the prompt, use the up and right keys (F3, F4) to input the password, and then press the Enter key (F5) to confirm it.

3. Wait until the test completes.

After five seconds, a pop window will appear to show the result of this diagnosis: rectifier, inverter, monitor OK or fault.

4. Stop the test.

If required, the test may be stopped before completion by selecting Stop testing on the Command menu.

Refer to *Chapter 4 Operator Control And Display Panel* for more information.

5.6 UPS Shutdown Procedures

5.6.1 Procedures For Completely Powering Down UPS

Complete UPS shutdown and load power-off should follow this procedure. All power switches, isolating switches and breakers are disconnected, and then UPS no longer supplies power to load.



The following procedures will cut off the load power, making the load completely power off.

1. Pressing the EPO button stops the operation of rectifier, inverter, static switch and battery.
2. If the UPS has internal battery, use the special tool to open the battery compartment door, then pull the three terminals 'BAT+', 'BAT-' and 'BAT N' (see Figure 5-3 for details). If the UPS has external battery, disconnect the corresponding switch of the external battery.
3. Disconnect the rectifier input switch Q1, bypass input switch Q2, output switch Q5. At the moment, all the internal power supply is closed and the LCD does not display any more.



Warning

1. Post a label at the AC input distribution (generally far away from the UPS) to alert that the UPS maintenance is being operated.
2. Wait 10 minutes for the internal DC bus capacitance discharging. Then the UPS is completely shut down.



Warning: hazardous battery voltage

The battery terminals still have hazardous voltage after the UPS is completely shut down.

5.6.2 Procedures For Completely Powering Down UPS While Maintaining Power To Load

The following procedures are applicable for completely powering down the UPS and still keeping the power supply to the load. Refer to the procedures in 5.3.4 *Transfer From Normal Mode To Maintenance Mode*.

5.7 EPO Procedures

The EPO is designed to switch off the UPS in emergency conditions (that is, fire, flood, etc.). To carry out EPO, you just need to press the EPO button, then the system will turn off the rectifier, inverter and stop powering the load immediately (including the inverter and bypass), and the battery stops charging or discharging.

After EPO, if the input mains is present, the UPS's control circuit will remain active; however, the output will be turned off. To remove all power from the UPS, first disconnect the external power switch of the UPS, and then pull the battery terminals (see Figure 5-3 for details).

5.8 UPS Reset Procedures After EPO

After shutting down the UPS through EPO or reasons of inverter overtemperature, overload, battery overvoltage and DC bus voltage, clear the fault according to the alarm message displaying on LCD screen. Then carry out the following reset procedures to make UPS resume normal operation.

After confirming the fault has been cleared and no remote EPO signal is received, the user can carry out the following procedures:

1. Press the FAULT CLEAR key over two seconds, the system will exit the EPO state, and the alarm indicator (red) is flashing.
2. Press and hold the ON key over two seconds, the inverter starts up, and the inverter indicator (green) is flashing. After the inverter runs normally, the UPS will be transferred from the bypass to inverter, and then the inverter indicator (green) is on.

**Note**

1. The rectifier will start and the bypass will begin to power the load. The rectifier indicator flashes while the rectifier is starting up. When the rectifier enters normal operation (about 30 seconds later), the rectifier indicator turns solid green.
2. The rectifier will start automatically when the overtemperature fault disappears five minutes after the disappearance of overtemperature signal.

3. After the EPO switch is pressed, if the mains input is cut off, the UPS will shut down completely. When the mains input returns, the UPS will start up on bypass. There will be power at the output terminals of the UPS.

**Warning**

If the maintenance bypass switch Q3 is closed, and UPS has input power, it means UPS has outputs.

5.9 Automatic Restart

In the case of a mains failure, the UPS draws power from the battery system to supply the load until the batteries are depleted. When the UPS reaches its EOD threshold, it will shut down.

The UPS will automatically restart and enable output power only when the following conditions are met:

1. If Auto Recovery after EOD Enabling is enabled.
2. After the Auto Recovery after EOD Delay Time expires (the default delay is 10 minutes), the UPS restarts bypass, then inverter. During the automatic recovery delay, the UPS will charge its batteries to provide a safety margin for equipment shutdown if input power fails again.
3. If the Auto Recovery after EOD Enabling feature is disabled, the user may restart the UPS manually by pressing the FAULT CLEAR key first for two seconds and then ON key for two seconds.

**Note**

During the automatic restart process, manual startup is disabled. Automatic restart must be set by Vertiv's authorized service engineer through Vertiv setting software.

5.10 Selecting Language

The LCD menu and data display is available in 17 languages: simplified Chinese, traditional Chinese, English, Dutch, French, German, Italian, Japanese, Polish, Portuguese, Russian, Spanish, Swedish, Finnish, Norwegian, Czech and Turkish.

Use the following procedures to select the language:

1. On the 'OutPut' menu screen, press the F3 (left) or F4 (right) key to select the 'Language' menu.
2. Press the F5 (enter) key to move the cursor to the data window of the screen.
3. Press the F3 (up) or F4 (down) key to select the desired language.
4. Press the F5 (enter) key to confirm.
5. Press the F2 (ESC) key repeatedly to return to the 'OutPut' menu.

At this point, the LCD displays all characters in the selected language.

5.11 Changing Current Date And Time

Use the following procedures to change the system date and time:

1. On the 'OutPut' menu screen, press the F3 (left) or F4 (right) key to select the 'Settings' menu.
2. Press the F5 (enter) key to move the cursor to the data window of the screen.
3. Press the F3 (up) or F4 (down) key to select the 'Date & time' item, and then press the F5 (enter) key to confirm.
4. Press the F3 (up) or F4 (down) key to the row displaying the date and time, and press the F5 (enter) key to confirm.
5. Use the F3 (up) or F4 (down) key to input the current date and time.
6. Press the F5 (enter) key to confirm, and press the F2 (ESC) key to return to the 'OutPut' menu.

5.12 Control Password

The system provides password protection for UPS operation and control. The default password is '12345'. Only enters the correct password can you execute the UPS self-test and battery test operation.

To change password, carry out the following procedures:

1. On the 'OutPut' menu screen, press the F3 (left) or F4 (right) key to select the 'Settings' menu.
2. Press the F5 (enter) key to move the cursor to the data window of the screen.
3. Press the F3 (up) or F4 (down) key to select the 'Command password' item, and press the F5 (enter) key to confirm, then 'Command password' is changed to 'Enter old password'.
4. Press the F4 key to move the cursor to corresponding password position, and press the F3 key to select the number from '0' ~ '9' for this position. After the five digits input, press the F5 (enter) key to confirm, at this moment, 'Command password' is changed to 'Enter new password'.
5. Similar to step 4, press the F3 and F4 to input new password and press the F5 (enter) key to confirm, at this moment, 'Command password' is changed to 'Enter new password again'.
6. Similar to step 4, press the F3 and F4 to input new password again, and press the F5 (enter) key to confirm, then press the F2 (ESC) key to return to the 'OutPut' menu.

Chapter 6 Battery

This chapter introduces the battery, including the battery safety, installation and maintenance information, battery protection function, as well as the connection of BCB box (optional).

6.1 Introduction

The UPS battery string is composed of several batteries in series connection and provides rated DC input voltage for the UPS inverter. The required battery backup time (i.e. the time for battery to supply load upon mains failure) is subject to the ampere-hour value of the battery. Sometimes, it is necessary to connect several strings of battery in parallel.

To facilitate the UPS installation, the battery is generally installed on the specially designed battery rack or in the battery room.

During the maintenance or repair, the battery must be disconnected from the UPS. This operation may be realized by the battery circuit breaker of proper capacity. This circuit breaker shall be located as close as possible to the battery connecting terminal, and the wiring distance of the power and signal cables connected to the UPS shall be minimized.

When several strings of battery are paralleled to increase the battery backup time, disconnecting device shall be equipped, so that the maintenance operation on a certain battery string will not affect the normal operation of other battery strings.

6.2 Safety

Take special care when working with the batteries associated with the UPS. When all the blocks are connected together, the battery string voltage can be up to 540Vdc. This is potentially lethal. Please follow the precautions for high voltage operation. Only qualified personnel are allowed to install and maintain the battery. To ensure safety, the external batteries are to be installed inside a lockable cabinet or in a purpose-designed, dedicated battery room, so that they are only accessible to qualified service personnel.

Confirm that the battery switch has been disconnected before battery maintenance.

 Warning: hazardous battery voltage present behind covers	
1. No user-serviceable parts are located behind covers that require a tool for their removal. Only qualified service personnel are authorized to remove such covers. 2. Before working on the copper bars connected to the external battery, please ensure they are disconnected from all power supplies.	
Proper connection mode	Improper connection mode
Tighten the terminal bolt of the battery with specified torque	Too large or too small torque may cause poor connection of the terminal. Under certain conditions, the terminal may have arcing or heat accumulation, which finally will cause fire





Warning: hazardous battery voltage present behind covers



3. Observe the following safety precautions when working on the batteries:

- a) The battery shall be firmly and reliably connected. After the connection is completed, the screw connections between all the terminals and the batteries shall be calibrated. The requirements on torque specified in the specifications or user manual provided by the battery manufacturer shall be satisfied. The connections between all the wiring terminals and the batteries shall be inspected and tightened at least once a year. Otherwise it may cause fire!
- b) The battery appearance must be inspected before accepting and using the battery. If there exists any package damage, dirty battery terminal, terminal erosion, rust, or enclosure crack, deformation or liquid leakage, replace it with a new battery. Otherwise, battery capacity reduction, electric leakage or fire may be caused.

Battery damaged during handling or transportation	After a week of normal charge/discharge experiment
	

- c) The battery is very heavy. Please use proper method to move and lift the battery, so as to prevent any damage to human being or the battery terminal. Severe damage to the battery may cause fire.
- d) The battery connecting terminal shall not be subject to any force, such as the pulling force or twisting force of the cable, otherwise, the internal connection of the battery may be damaged. Severe damage to the battery may cause fire.
- e) The battery shall be installed and stored in a clean, cool and dry environment. Do not install the battery in a sealed battery chamber or a sealed room. The battery room ventilation shall at least meet the requirement of EN50272-2001. Otherwise, battery bulging, fire or even human injury may be caused.
- f) The battery shall be installed far away from the heating products (e.g. transformer), used or stored far away from any fire source, and shall not be burnt or put into fire for heating. Otherwise, battery leakage, bulging, fire or explosion may be caused.
- g) Do not directly connect any conductor between the positive and negative terminals of the battery. Remove the finger rings, watch, necklace, bracelet and other meta items before operating the battery, and ensure that the tools (e.g., wrench) are covered with insulating material. Otherwise, battery burning, human death/injury or explosion may be caused.
- h) Do not disassemble, modify or demolish the battery. Otherwise, battery short circuit, liquid leakage or even human injury may be caused.

**Warning: hazardous battery voltage present behind covers**

- i) Clean the battery enclosure with the wringed wet cloth. To avoid any static or arcing, do not use dry cloth or duster to clean the battery. Do not use the organic solvent (such as thinner, gasoline, volatile oil) to clean the battery. Otherwise, the battery enclosure may be cracked. In worst case, fire may be caused.
- j) The battery has diluted sulfuric acid. In normal use, the diluted sulfuric acid will be absorbed to the baffle and polar plate of the battery. However, if the battery is damaged, the acid may leak from the battery. Therefore, personal protective equipment (e.g., protective glasses, rubber gloves and apron) must be used when operating the battery. Otherwise, if the diluted sulfuric acid enter the eyes, blindness may be caused; if it contacts the skin, the skin may be burnt.
- k) The battery may have short circuit, electrolyte dry-up or positive pole erosion failure at the end of its life. If it is still used under this state, the battery may have thermorunaway, bulging or liquid leakage. Please replace the battery before it becomes this state.
- l) Before connecting or disconnecting the battery connection cables, please isolate the charging power.
- m) Check if the battery has been unexpectedly earthed. If this is the case, remove the earth connection. Contact with any part of the earthed battery may result in an electric shock.

6.3 UPS Battery

The UPS generally adopts valve-regulated battery. At present, 'valve-regulated' means the 'sealed type' or 'maintenance free' mentioned in the past.

The valve-regulated battery is not completely sealed, especially when it is over-charged, there will be gas escape. The volume of the gas escape is less than the water injection battery. However, during the installation design of the battery, temperature rise shall be taken into account, and enough room shall be reserved to ensure good ventilation.

Besides, the valve-regulated battery is not maintenance free. The valve-regulated battery must be kept clean, and it shall be inspected regularly to check if the connection is reliable, and if it is corroded. For details, please refer to 6.11 *Battery Maintenance*.

It is suggested to connect no more than 4 strings of batteries in parallel. Batteries of different types, names or newness shall not be used together. Otherwise, the battery inconsistency will cause frequent over-discharge or under-charge of certain battery. At last, the battery will have premature failure, and the entire string of battery will have insufficient backup time.

The battery must be stored in fully charged state. The battery will lose certain capacity because of self discharge during the transportation or storage. Charge the battery before use. During the storage, ensure that the ambient temperature shall not exceed the range of $-15^{\circ}\text{C} \sim +45^{\circ}\text{C}$, and the optimal temperature is $20^{\circ}\text{C} \sim 25^{\circ}\text{C}$. To compensate for the self discharge of the battery during the storage, the battery shall be charged every 3 months during the storage. The specific time may differ for different batteries. For details, refer to the requirement of the battery manufacturer.

It is very important to fully charge the battery before carrying out onsite test on the battery backup time. The test may take several days. Therefore, it should be conducted after the battery has been subject to uninterrupted float charging for at least one week.

When the battery has been running for several weeks or subject to two to three charge and discharge cycles, the battery performance will be increased.

To avoid the battery over-charge or under-charge, please set the battery management parameters according to the equalizing/float charge voltage and temperature compensation factor specified in the manuals provided by the battery manufacturer. Please charge the battery immediately after discharge.

6.4 Precautions For Installation Design



Note

Precautions for installation, use and maintenance of the battery are described in the relevant battery manual provided by the battery manufacturer. The safety precautions described in this section include the important matters that must be considered during the installation design. The design results may be changed according to the local situations.

6.5 Battery Installation Environment And Number Of Batteries

6.5.1 Installation Environment

Fresh air volume (EN50272-2001)

The operating environment of the battery must be ventilated. During the operation of the battery, the following requirement for the fresh air ventilation shall be satisfied:

$$Q=0.05 \times n \times I_{gas} \times C_{rt} \times 10^{-3}[\text{m}^3/\text{h}]$$

Where:

Q—The fresh air ventilation volume per hour, the unit is m^3/h

n—Number of cells

I_{gas} —The gas evolving current density under battery float charging or boost charge conditions, the unit is mA/Ah

$I_{gas}=1$, under the float charging condition of 2.27V/cell

$I_{gas}=8$, under the boost charge condition of 2.35V/cell

C_{rt} —20hr battery rated capacity

Temperature

Table 6-1 Ambient temperature range

Type	Temperature value	Remark
Recommended optimal temperature	20°C ~ 25°C	The ambient temperature for the battery operation shall not be too high or too low.
Short time allowable temperature	-15°C ~ 45°C	If the average operating temperature of the battery rises from 25°C to 35°C, the service life of the battery will be reduced by 50%. If the operating temperature of the battery is over 40°C, the service life of the battery will be reduced exponentially each day

The higher the temperature is, the shorter the battery service life will be. At low temperature, the charge/discharge performance of the battery will be significantly reduced.

The battery must be installed in cool and dry environment with the humidity less than 90%, and be protected from the heat source and direct sunshine.

The ambient temperature, ventilation, space, float/boost charge voltage and ripple current will affect the battery temperature. Uneven temperature among the battery strings will cause uneven voltage distribution and thus result in problem. Therefore, it is very important to maintain balanced temperature in the battery string, and the temperature difference between batteries of different layers shall be kept

within 3°C. Valve-regulated battery is very sensitive to the temperature, therefore, valve-regulated battery shall be used in 15°C ~ 25°C. If the battery cabinet is installed near the UPS, the maximum design ambient temperature shall be determined according to the battery rather than the UPS. That is, if valve-regulated battery is used, the indoor ambient temperature shall be 15°C ~ 25°C rather than the operating temperature range of the main equipment. Under the precondition that the average temperature will not exceed 25°C, it is allowed to have short time temperature deviation.

6.5.2 Number Of Batteries

The number of batteries, EOD voltage, and float charging voltage under the 380V/400V/415V voltage system are consistent, as shown in Table 6-2.

Table 6-2 Number of batteries

Parameter	380V/400V/415V
Number of cells (standard)	192 ~ 240 PCS
EOD voltage	1.60Vdc/Cell ~ 1.85Vdc/Cell, 1.62V/cell recommended
Float charging voltage	2.15Vdc/Cell ~ 2.3Vdc/Cell, 2.27V/cell recommended

6.6 Battery Protection

The UPS inside has a fuse switch to protect the internal battery. The Vertiv BCB (optional) is recommended to protect the external battery.

The external battery is connected to the UPS through the BCB. The BCB can be manually closed and has the electronic tripping device controlled by the UPS control circuit. If the battery adopts rack mounting (or is far away from the UPS cabinet), the BCB shall be installed as close to the battery as possible, and the wiring distance of the power and signal cables connected to the UPS shall be minimized.

The BCB has the following features:

- 1) Isolated with the battery, safe and reliable
- 2) Short circuit protection
- 3) In case the inverter is locked because of battery under-voltage, the circuit breaker will be disconnected automatically to avoid battery over-discharge
- 4) If remote EPO button is installed, the EPO button can be used to disconnect the circuit breaker
- 5) Mis-operation protection

To obtain the required backup time, the batteries may be connected in parallel. In this situation, the BCB shall be installed in the after-stage of all the paralleled batteries.



Note

Only trained personnel shall operate and maintain the battery circuit breaker.

6.7 Battery Installation And Connection

6.7.1 Battery Installation

1. Before installation, check the battery appearance to ensure that there is no damage, inspect and count the accessories, and carefully read this manual and the user manual or installation instruction provided by the battery manufacturer.

2. There shall be at least 10mm gap between the batteries in vertical direction, to ensure the free circulation of the ambient air of the batteries.
3. Certain clearance shall be maintained between the battery top and the upper layer to facilitate the monitoring and maintenance of the battery.
4. The batteries shall be installed from the bottom layer and from bottom to top, so as to avoid a too high gravity center. The battery shall be properly installed and protected from vibration or shock.

6.7.2 Battery Connection

1. All the battery cabinets or battery racks must be connected together and properly grounded.
2. When multiple batteries are used, they shall be connected in series and then in parallel. Before loading and power-up, it must be detected that the total voltage of the batteries is as specified. The negative and positive poles of the batteries must be connected to the negative and positive battery terminals of the UPS according to the labels on the battery and UPS. If the battery is reversely connected, explosion and fire may be caused, it may result in battery and UPS damage or even human injury.
3. When the battery cable connection is completed, install insulating shield for the terminals.
4. When connecting the cable between the battery terminal and the BCB, the BCB terminal shall be connected first.
5. The bending radius of the cable shall be larger than 10D, wherein D is the outer diameter of the cable.
6. When the battery cable is connected, it is prohibited to pull the battery cable or the cable terminal.
7. Do not cross the battery cables during the connection, and do not tie the battery cables together.
8. See Figure 6-1 for battery connection.

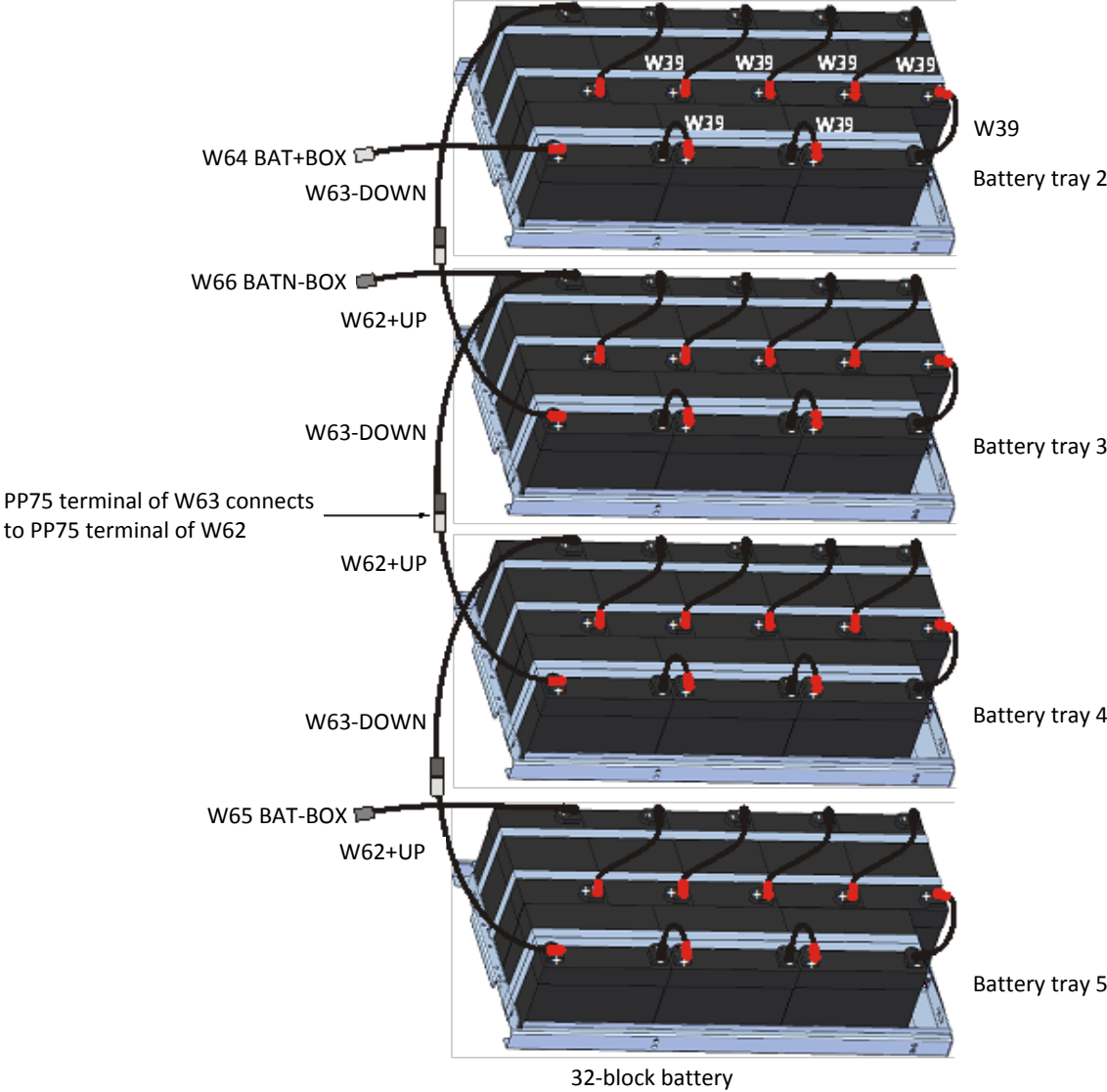

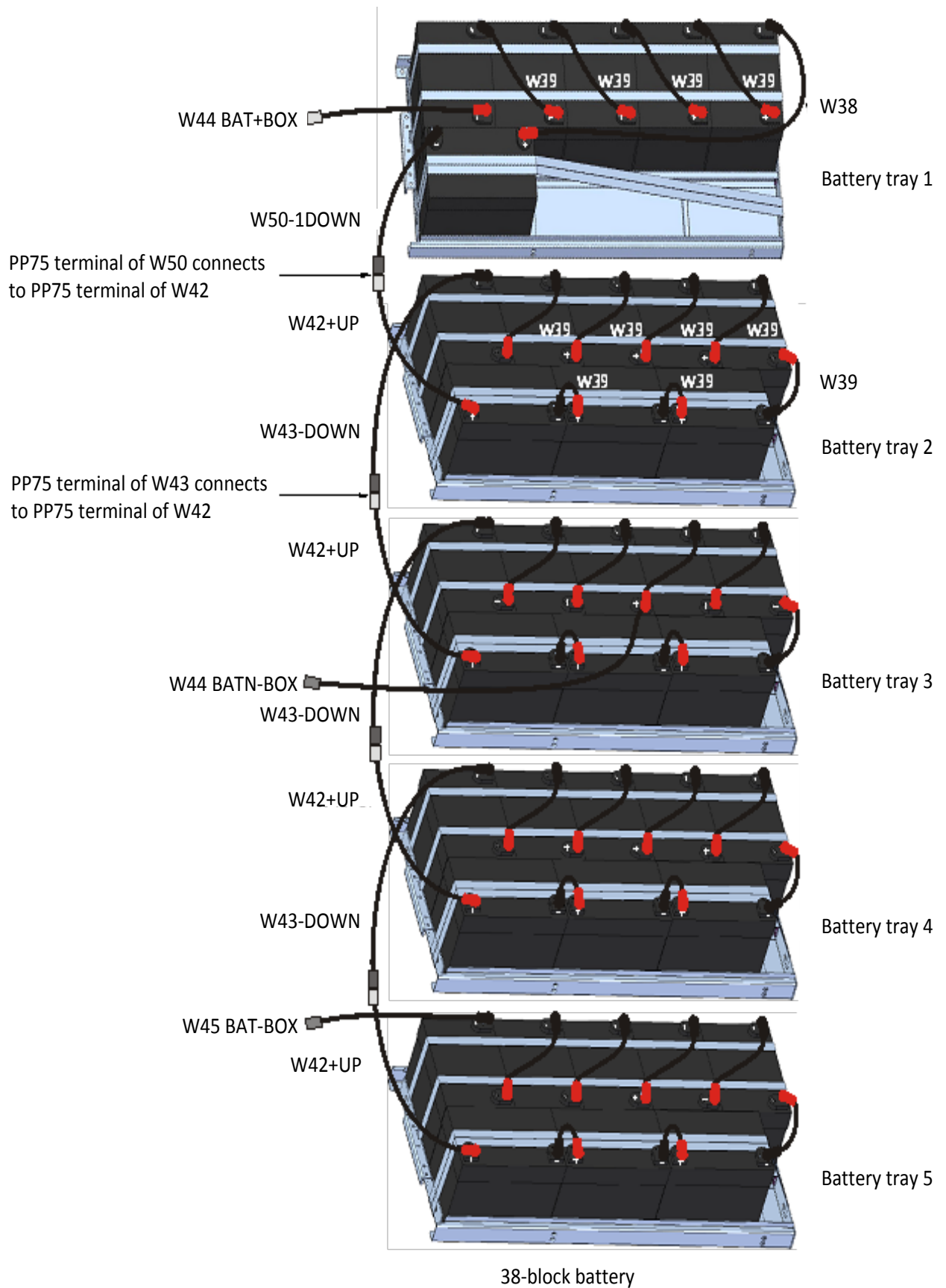

Figure 6-1 Connection for internal batteries

6.8 Design Of Battery Room

No matter which type of installation system is adopted, the following items shall be paid special attention to (refer to Figure 6-2):

❶ Layout of cells

No matter which battery installation system is used, the battery shall be located in a matter that it will not contact two naked live parts with the potential difference over 150V at the same time. If it is unavoidable, insulated terminal shield and insulated cable shall be used for the connection.

❷ Workbench

The workbench (or pedal) must be skid-proof and insulated, and at least 1m wide.

❸ Wiring

All the wiring distances shall be minimized.

❹ BCB

The BCB is generally installed in the wall-mounted box near the battery.

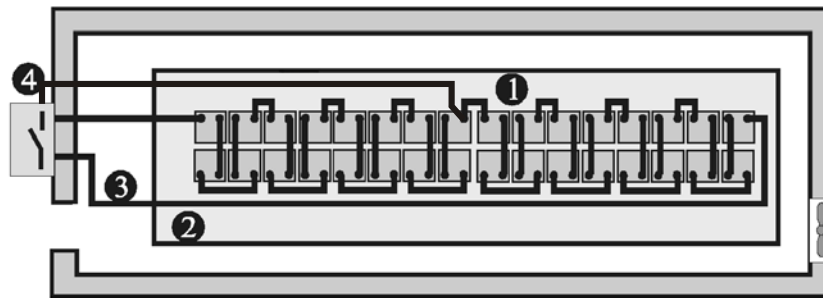

Figure 6-2 Battery room design

6.9 BCB Box (Optional)

The BCB box contains a BCB and a BCB control board.

Vertiv provides the BCB box and BCB signal cables (length: 30m) for use when the battery does not install in the battery cabinet. In this situation, The BCB box is fitted as close as possible to the battery and connected to the UPS. Refer to Figure 6-3 and Table 6-4 for description of the BCB box and its components.

The BCB box protects the battery against overdischarge and overcurrent, and also isolates the UPS and battery, thus reducing the risk at lowest for service personnel during the maintenance. The box inside has connection bars for connecting the power cables from the UPS and batteries.

Note: The signal cables from the UPS to the BCB control board must be routed in a separate cable trough and separated from battery power cables. The separate safety earth must be connected between the UPS and BCB box.

The BCB box is provided as follows according to different UPS rated power.

Table 6-3 Parameters of BCB box

Dimensions (H × W × D) (mm)	Weight (kg)	BCB
558 × 378 × 180	21.5	160A, 4 poles



Note

This weight excludes the packing.

The BCB has the following advantages:

Short circuit protection and EOD protection. When the battery voltage drops to EOD, the BCB will be switched off automatically.

UPS EPO. When pressing the EPO button, the BCB will be switched off automatically.

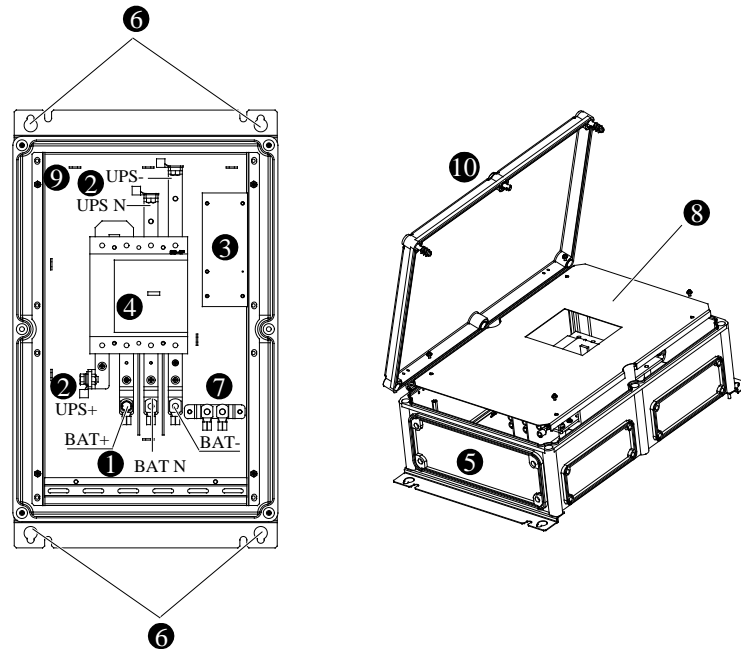

Figure 6-3 BCB box

Table 6-4 Description of BCB box components

No.	Component
1	Battery connection terminal (+/N/-)
2	UPS connection terminal (+/N/-)
3	Battery switch control board
4	Battery switch
5	Cabling hole for confirming the cable size and opening hole
6	Wall-mounted installation hole
7	Grounding bar
8	Insulating plate
9	Base plate
10	Visible cover



Note

The BCB box generally uses bottom cabling mode, but you can rotate its bottom plate to use top cabling mode.

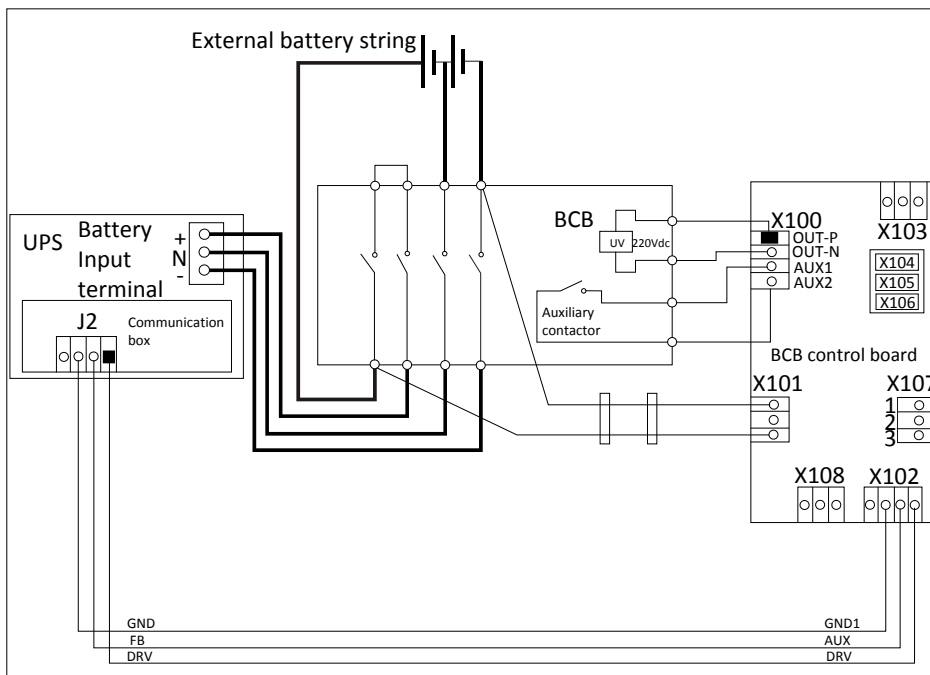

Note:

1. See Table 6-5 for definition of port X102.
2. X101-Hazardous Voltage: Do not connect this port to the battery unless a permission given by the service engineer.
3. X103~X106 are used to connect temperature sensors from multiple battery cabinets.
4. X107 is used to set jumpers according to whether the UPS has been installed a battery cold button. If yes, jumpers 1, 2 setting is recommended; if not, jumpers 2, 3 setting is required.

Figure 6-4 Connection of BCB box

Table 6-5 Battery control port (X102)

BCB box port	Communication box port (J2)	Meaning	Signal state
DRV	DRV	Tripping control signal of BCB from the UPS	Normal: high level, BCB closed; Abnormal: low level, BCB open
IN (AUX)	FB (IN)	Auxiliary contact of BCB (contact off means BCB off)	Normal: OV, BCB closed; Abnormal: open, BCB open
GND1	GND	Signal ground	GND1 to GND

Note: The cable of the X102 BCB port must be routed separately from the power cable. It uses the dual-insulated shielded cable (the CSA is generally 0.5mm² ~ 1mm² when the wiring distance is 25m ~ 50m length), and the two ends of the shielding coat must be connected to the enclosure reliably. The separate safety earth must be connected between the UPS and BCB box.

Caution

If the corresponding functions are not required, just do not connect corresponding terminals.

6.10 BCB Reference Current And Connection

Table 6-6 provides recommended BCB rated current and battery maximum discharge current at full load. Refer to Table 3B in IEC60950-1, and select the appropriate cable CSA according to local electrical regulations.

Table 6-6 BCB rated current and battery max. discharge current at full load (recommended)

Item		Unit	UPS rating (kVA)	
			30kVA	40kVA
32-block battery	Maximum battery discharge current at full load	A	95	127
	Reference rated current of BCB	A	160	
34-block battery	Maximum battery discharge current at full load	A	88	116
	Reference rated current of BCB	A	160	
36-block battery	Maximum battery discharge current at full load	A	82	108
	Reference rated current of BCB	A	160	
38-block battery	Maximum battery discharge current at full load	A	76	101
	Reference rated current of BCB	A	160	
40-block battery	Maximum battery discharge current at full load	A	72	95
	Reference rated current of BCB	A	160	



Note

Refer to Figure 6-5 for the connections between the battery, BCB and UPS.

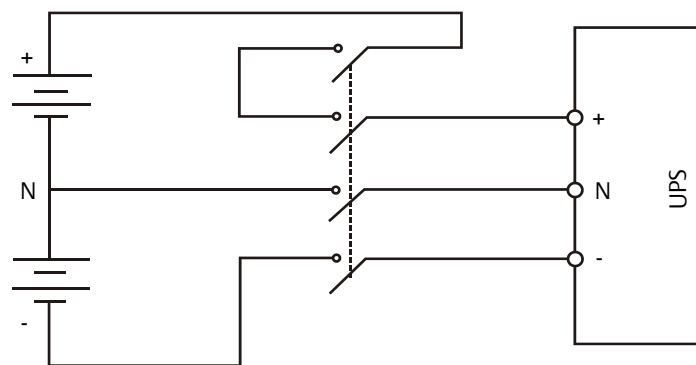

Figure 6-5 Connections between the battery, BCB and UPS

6.11 Battery Maintenance

For the battery maintenance and maintenance precautions, refer to IEEE-Std-1188-2005 and the relevant manuals provided by the battery manufacturer.



Note

1. Periodically check the screws of the battery connection parts and confirm that they are firmly tightened. If there is

any loosened screw, tighten it immediately.

2. Ensure that all safety devices are in place and operate normally, and that the battery management parameters are set properly.

3. Measure and record the air temperature inside the battery room.

4. Check to ensure that the battery terminals have no damage or heat generating trace, and the battery enclosure and terminal shields are intact.

6.12 Disposal Of Used Battery

If the battery has liquid leakage or is damaged, place the battery into the container that can withstand sulphuric acid and discard it according to the local regulations.

Used lead acid storage battery belongs to dangerous waste, and it is a key item for used battery pollution control. The storage, transportation, use and disposal of the battery shall comply with the national and local laws and regulations on dangerous waste and used battery pollution prevention and other standards.

According to the relevant national regulations, the used lead acid storage battery must be recycled and shall not be disposed of with other methods. Random discard or any other improper disposal of the used lead acid storage battery may cause severe environment pollution and the relevant person will be investigated of corresponding legal responsibilities.

Chapter 7 Parallel System And LBS System

This chapter gives details on the installation of parallel system and LBS system.

7.1 General

The parallel system can comprise of up to four UPS modules of the same power rating and connected in parallel without the need for a centralized mains static bypass. Instead the bypass static switches of each UPS share the load when the system transfers to the mains bypass supply.

From a 'power' viewpoint, each module is internally identical to the 'single module' configuration. A parallel system requires inter-module control signals to manage the load sharing, synchronizing and bypass switching. The control signals are connected through the parallel cables, which are multi-way ribbon cables connected between the units of the system to form a ring.

When two or more modules are to be connected in parallel, it is recommended that the inductor should be inserted in the static bypass line. This can be installed internal to the UPS as an option.

7.2 System Installation Procedures

The basic installation procedure of a parallel system comprising two or more UPS modules is the same as that of single module system. This section only introduces the installation procedures specific to the parallel system. The installation of a parallel UPS should follow the installation procedure for a single UPS module with the additional requirements detailed in this section.

7.2.1 Preliminary Checks

Be sure that the options of the parallel cables are correct, and that the modules are of the same rating, model, and with the same software and hardware release.



To achieve coordinated operation of the modules in the parallel system, it is required to configure each module separately using Vertiv setting software. This must be done by Vertiv service personnel.

7.2.2 Cabinet Installation

Place the UPS modules side by side and interconnect them as shown in Figure 7-1. The output distribution mode (Q1EXT, Q2EXT must be configured) shown in Figure 7-1 is recommended to facilitate maintenance and system testing.

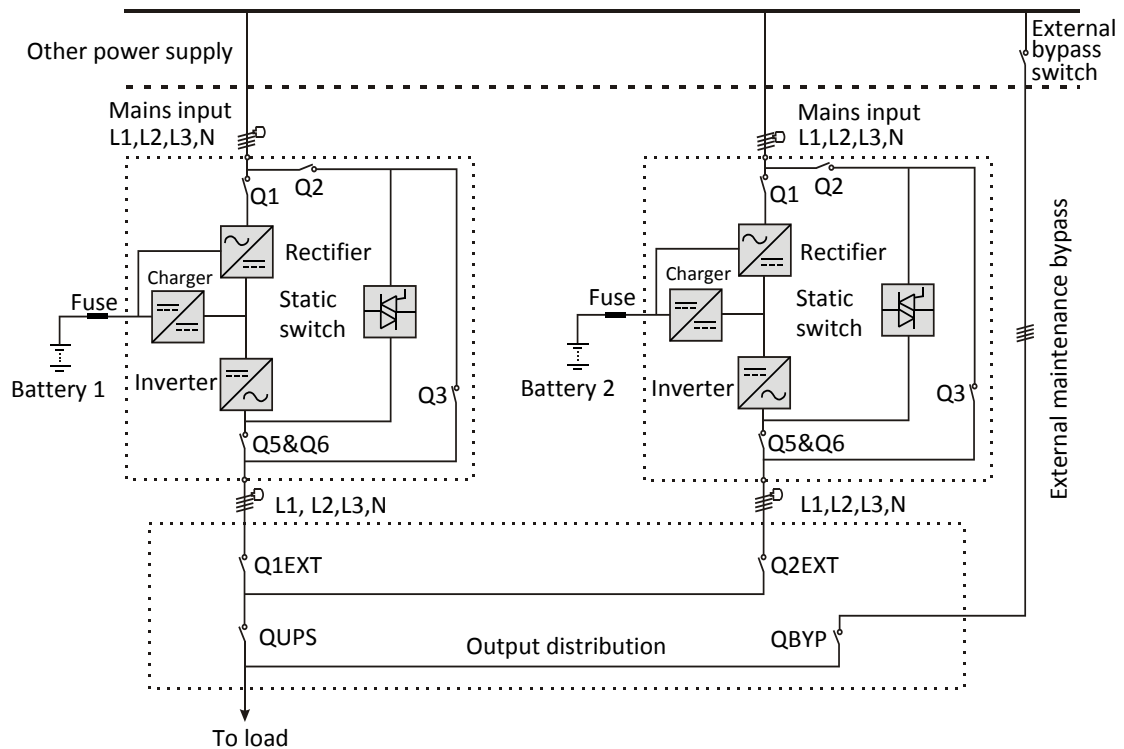

Figure 7-1 Schematic of typical parallel system (with common input, separate batteries and output)

7.2.3 Power Cable

The power cable wiring is similar to that of the UPS module. Refer to 3.1 *Wiring Of Power Cable*.

The bypass and rectifier input supplies must use the same neutral line input terminal. If the input has a current leakage protective device, the current leakage protective device must be fitted upstream of the neutral line input terminal.



Note

The power cables (including the bypass input cables and UPS output cables) of each UPS module should be of the same length and specifications to facilitate load sharing.

7.2.4 Parallel Cable

Shielded and double-insulated parallel cables available in lengths 5m, 10m and 15m must be interconnected in a ring configuration between the UPS modules, as shown in Figure 7-2. Method: connect a module parallel cable from its PARA1 port to the PARA2 port of another module. Follow this method to connect other parallel cables.

The ring connection ensures the reliability of the control of the parallel system. Be sure to verify the reliable cable connection before starting up the system!

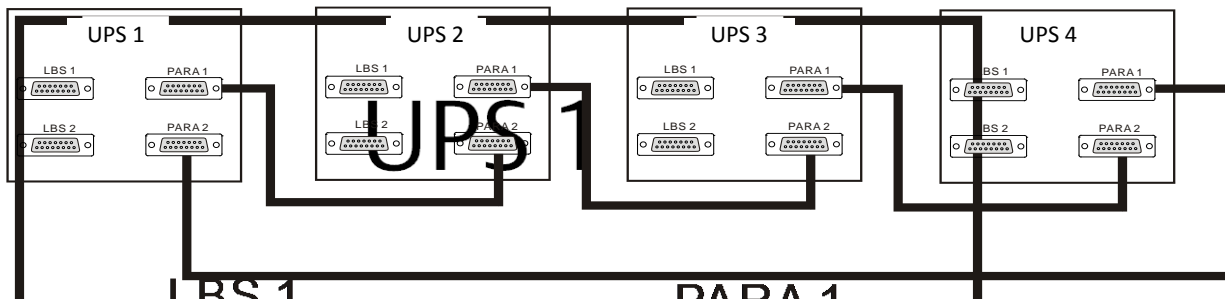

Figure 7-2 Parallel signal cables connection (Parallel system)

7.2.5 Remote EPO

In addition to the EPO switch provided on the operator control and display panel of each UPS module for controlling the EPO of each module respectively, the parallel system also provides remote EPO function for controlling all UPS modules to shut down simultaneously from a remote terminal, as shown in Figure 7-3.

Note

1. The remote EPO switch must provide dry contact signal, which is normally open or normally closed.
2. The open circuit voltage provided is 12Vdc, < 20mA.
3. The external EPO device can be composed of another control system which can disconnect UPS mains supply or bypass input.

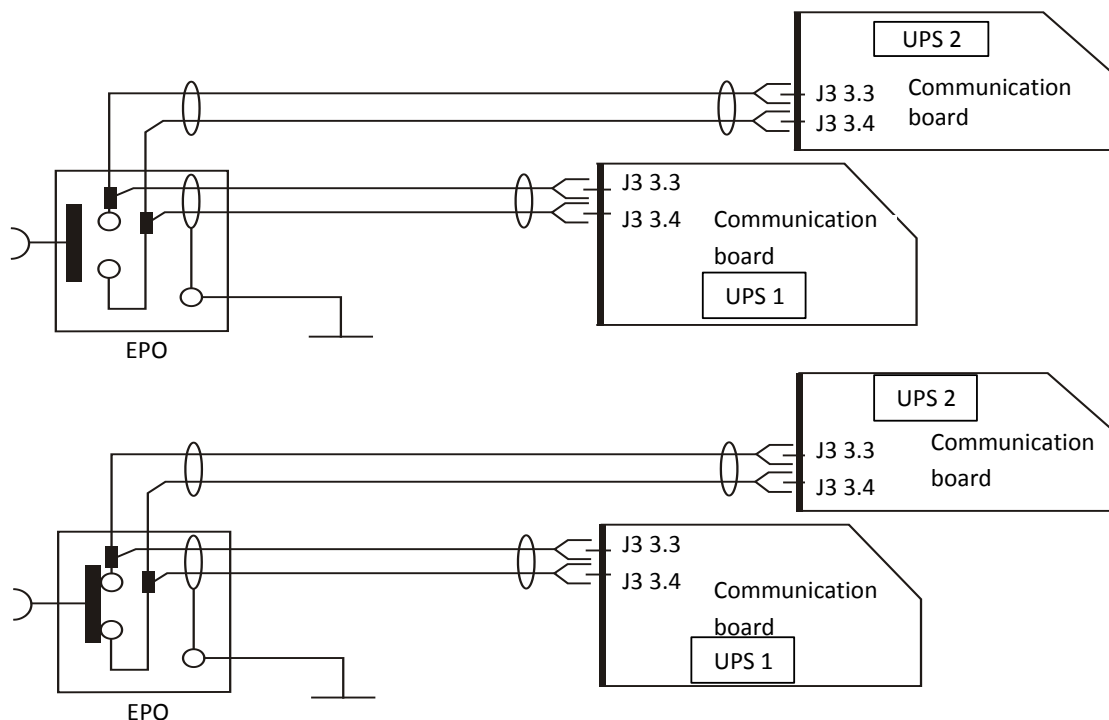

Figure 7-3 EPO circuit diagram

Note: In Figure 7-3, the upper one is Normally Open type, and the lower one is Normally Closed type.

7.3 Ion Procedures For Parallel System

Warning

If UPS input uses RCD, differential switch is only used in the system's bypass mains supply. At the moment of electrical connection, current may not be immediately separated, which may result in the tripping of RCCB respectively.

Only one step is needed for once, and only after finishing this operation step of each UPS module, the next step can be carried on.

7.3.1 Startup Procedures In Normal Mode

These procedures are applicable to start the UPS under total power-down state, which means the UPS or the maintenance bypass switch has not supplied the load before. Make sure UPS has been completely installed and commissioned by the engineer, and external power supply switch has been turned off.



Warning

1. These procedures result in mains voltage being applied to the UPS output terminals.
2. If any load equipment is connected to the UPS output terminals, check with the user that it is safe to apply power. If the load is not ready to receive power, disconnect the downstream load switch, and stick a warning label on the connection point of the load.

Use the following procedures to turn on the UPS from a fully powered down condition.

1. Confirm that the total external maintenance bypass switches are disconnected. Open the front door of each UPS in turn, ensure that the internal maintenance bypass switch Q3 is disconnected and switch Q6 is closed, while the input cables and copper bars are reliably connected, and the parallel cables are firmly connected.



Warning

All operations relating to disconnect or close the maintenance bypass switch shall be finished within three seconds, to avoid misreporting as faults.

2. Close the total bypass input switches.
3. Close the bypass input switch Q2, rectifier input switch Q1, output switch Q5 and all external output isolating switches (if any) of each UPS in turn.

At the moment, the system is powered on, and the startup screen pops up. Refer to 4.2.1 *Start Screen*.

About 25 seconds later, confirm that the LCD shows the rectifier power supply and the bypass power supply are normal; if not, check whether the switches Q1 and Q2 are closed and the parallel cables of each UPS are connected reliably. Then the rectifier starts up and the alarm indicator (red) is on, at the same time, the bypass static switch is closed. About 30 seconds later, the alarm indicator (red) is flashing, then the rectifier startup is finished. After all the rectifiers startup of the UPSs is finished, the alarm indicators (red) are flashing.

4. For each UPS, press the ON key for two seconds. The inverter starts up, and the inverter indicator (green) of each UPS is flashing. After all the UPS inverter indicators turn solid green, the whole UPS system will power the load.

7.3.2 Maintenance Bypass Procedures



Warning

If the UPS system is composed of more than 2 parallel UPS modules, and the load capacity exceeds the single module capacity, do not use the internal maintenance bypass switch.

This operation will make the load transfer from UPS power supply protection state to direct connection with AC input bypass state.



Caution: power supply interruption danger of the load

Before performing this procedure, you should check the LED information first, and make sure the bypass is normal and inverter synchronized. Otherwise, it may result in the load power interruption for a while.

1. Press the OFF key of each UPS in turn for two seconds. The inverter indicators are off and the buzzer alarms. The load transfers to the static bypass, and the inverter shuts down. At last, all UPSs are transferred to load supply mode.



Note

Press the ALARM CLEAR button can silence the alarm, but the alarm message of the the LCD does not disappear until the alarm status is cleared.

2. Close the UPS external total maintenance bypass switches, and do not close the internal maintenance bypass switch Q3 of each UPS.

3. At this moment, the external total maintenance bypass should be parallel connected with each UPS's static switch.

4. At this moment, the LCD of each UPS displays 'Maint. sw. closed'.

5. Disconnect the output switch Q5 and neutral line switch Q6 of each UPS in turn, and the maintenance bypass can supply power to the load.



Caution

When the UPS is in maintenance mode, the load does not have the mains abnormal protection.

6. Pressing the EPO button of each UPS stops the operation of rectifier, inverter, static switch and battery, but this action will not affect the maintenance bypass power the load normally.



Note

In maintenance mode, the load is directly fed by the mains power instead of the pure AC power from the inverter.

7. If the UPS has internal battery, use the special tool to open the battery compartment door, then pull the three terminals 'BAT+', 'BAT-' and 'BAT N' (see Figure 5-3 for details). If the UPS has external battery, disconnect the corresponding switch of the external battery. All UPS modules should be disconnected from the batteries.

8. Disconnect the rectifier input switch Q1 and bypass input switch Q2 of each UPS in turn.

At the moment, all the internal power supply is closed and the LCD does not display any more.



Warning

1. If the maintenance is required, wait 10 minutes for the internal DC bus capacitance discharging.
2. The parts of UPS circuits also have hazardous voltage, though the rectifier input switch, bypass input switch and battery switch are disconnected. Therefore, the UPS maintenance is suitable for qualified personnel only.

7.3.3 Procedures For Isolating One UPS Module From Parallel System



Important

These procedures shall only be carried out by service personnel of Vertiv or under their guidance.



Warning

Before operation, confirm that the system capacity has redundancy to avoid system shutdown due to overload.

The following procedures apply when one UPS module must be isolated from the parallel system for repair due to serious fault:

1. Pressing the EPO button stops the operation of rectifier, inverter, static switch and battery, but this action will not affect other UPSs in parallel system to power the load normally.
2. If the UPS has internal battery, use the special tool to open the battery compartment, then pull the three terminals 'BAT+', 'BAT-' and 'BAT N' (see Figure 5-3 for details). If the UPS has external battery, disconnect the corresponding switch of the external battery.
3. Disconnect the rectifier input switch Q1 and bypass input switch Q2, and disconnect the output switch Q5 and neutral line switch Q6.

At the moment, all the internal power supply is closed and the LCD does not display any more.



Warning

1. Post a label at the AC input distribution (generally far away from the UPS) to alert that the UPS maintenance is being operated.
2. Wait 10 minutes for the internal DC bus capacitance discharging. Then the UPS is completely shut down.

7.3.4 Procedures For Inserting One Isolated UPS Module In Parallel System



Important

These procedures shall only be carried out by service personnel of Vertiv or under their guidance.

The following procedures are used to reintegrate a UPS module that has been previously isolated from the parallel system:

1. If the UPS is connected with a battery, just close the battery external distribution switch or three terminals 'BAT+', 'BAT-' and 'BAT N' (see Figure 5-3 for details). Then close the rectifier input switch Q1 and neutral line switch Q6.

At the moment, the system is powered on, and the startup screen pops up. Refer to [4.2.1 Start Screen](#).

2. Close the bypass input switch Q2.

At this moment, confirm that the LCD shows the bypass input supply is normal; if not, check whether the switch Q2 is closed. Then the rectifier starts up and the alarm indicator turns solid red. About 30 seconds later, the alarm indicator (red) is flashing (if the UPS has internal or external battery not connected) or off (if the UPS has internal or external battery connected).

3. Close the output switch Q5, and press the ON key for two seconds.

The inverter starts up, and the inverter indicator (green) is flashing. After the inverter runs normally, the inverter indicator turns solid green, and the inverter supplies power to the UPS.

At this point, the UPS will join the operation of the parallel system, and supply power to the load.

7.3.5 Procedures For Completely Powering Down UPS

Complete UPS shutdown and load power-off should follow this procedure. All power switches, isolating switches and breakers are disconnected, and then UPS no longer supplies power to the load.



Caution

The following procedures will cut off the load power, making the load completely power off.

1. Pressing the EPO button of each UPS stops the operation of rectifier, inverter, static switch and battery.
2. If the UPS has internal battery, use the special tool to open the battery compartment, then pull the three terminals 'BAT+', 'BAT-' and 'BAT N' (see Figure 5-3 for details). If the UPS has external battery, disconnect the corresponding switch of the external battery. All UPS modules should be disconnected from the batteries.
3. Disconnect the rectifier input switch Q1 and bypass input switch Q2 of each UPS. At the moment, all the internal power supply is closed and the LCD does not display any more.
4. Disconnect the output switch Q5 of each UPS.



Warning

1. Post a label at the AC input distribution (generally far away from the UPS) to alert that the UPS maintenance is being operated.
2. Wait 10 minutes for the internal DC bus capacitance discharging. Then the UPS is completely shut down.



Warning: hazardous battery voltage

The battery terminals still have hazardous voltage after the UPS complete shutdown.

7.3.6 Procedures For Complete UPS Shutdown While Maintaining Power To Load

The following procedures are applicable for completely powering down the UPS and still keeping the power supply to the load. Refer to the procedures in 7.3.2 *Maintenance Bypass Procedures*.

7.4 LBS System

7.4.1 Cabinet Installation

An LBS system consists of two independent UPS systems, each containing one or more parallel UPS modules, as shown in Figure 7-4 and Figure 7-5. The LBS system has high reliability and is suitable for load with multiple inputs. For single-input load, an STS can be installed to feed power to the load.

The system uses the LBS cables to keep the output of the two independent (or parallel) UPS systems in synchronization. One system is designated as the master, the other is designated as the slave. The operation modes of the parallel system comprise master and/or slave operation in normal or bypass mode. Place the UPS modules side by side and interconnect the UPS modules according to the following instructions.

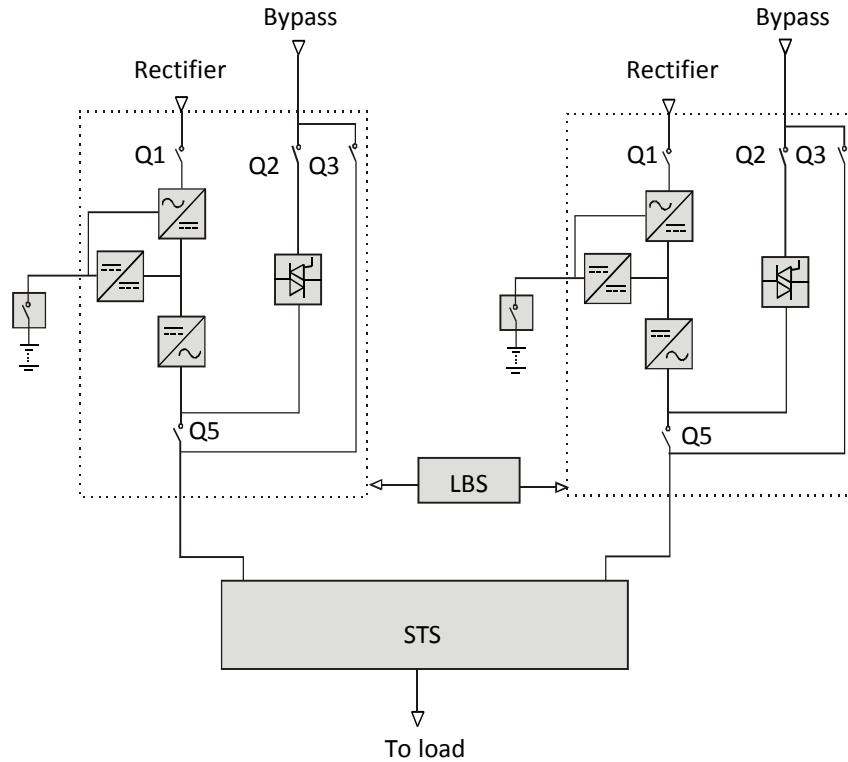

Figure 7-4 LBS system (UPS module)

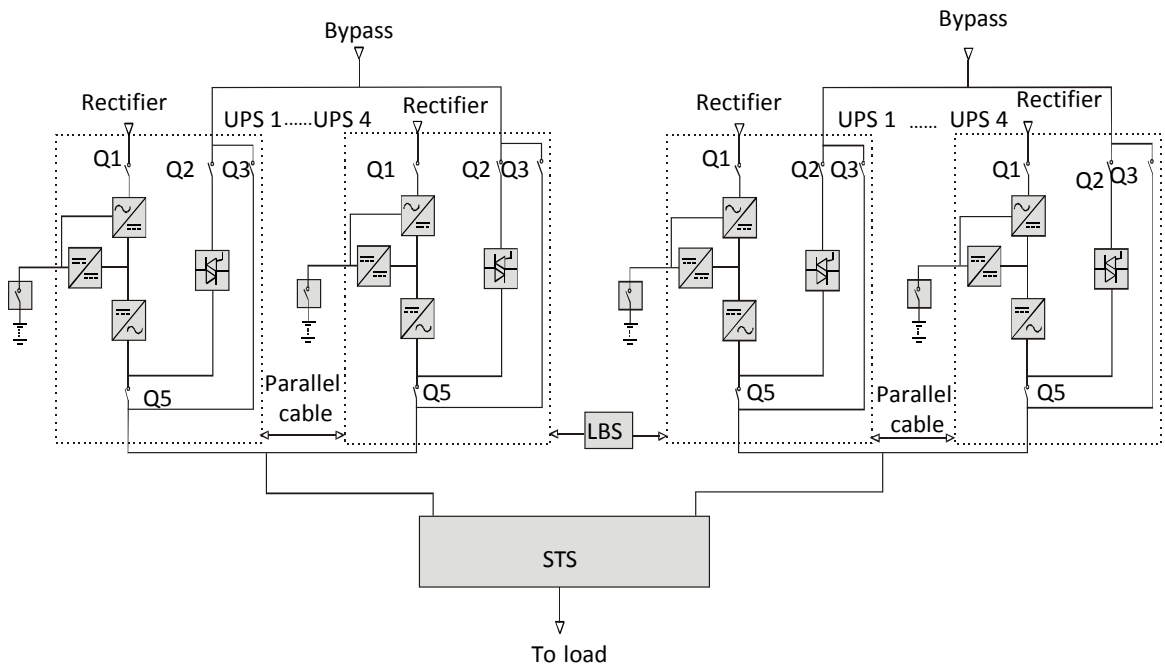

Figure 7-5 LBS system (parallel system)

Note
 In a dual-bus system, the two UPS systems must have the same power rating, voltage and frequency, and the load must not exceed the power rating of a UPS module system.

7.4.2 External Protective Device

Refer to 3.1.9 External Protective Device.

7.4.3 Power Cable

The power cable of dual-bus power system is similar to that of single system. Refer to 3.1 Wiring Of Power Cable.

7.4.4 LBS Cable

The shielded and double-insulated parallel cables are available in lengths 5m, 10m and 15m. Connect the two optional LBS cables in a ring configuration: from the LBS1 port of one UPS module to LBS2 port of another UPS module, and from the LBS2 port of one UPS module to LBS1 port of another UPS module, as shown in Figure 7-6 and Figure 7-7.

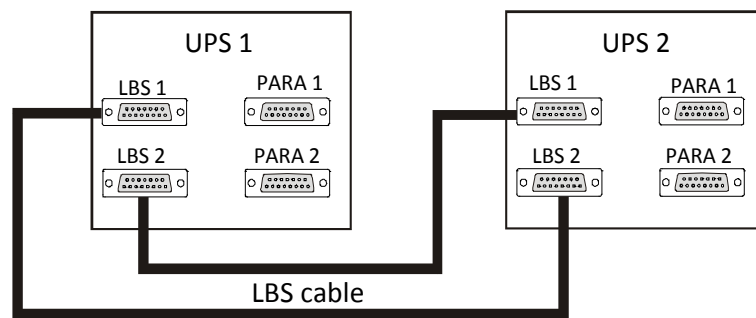

Figure 7-6 Connection of typical LBS system (UPS module)

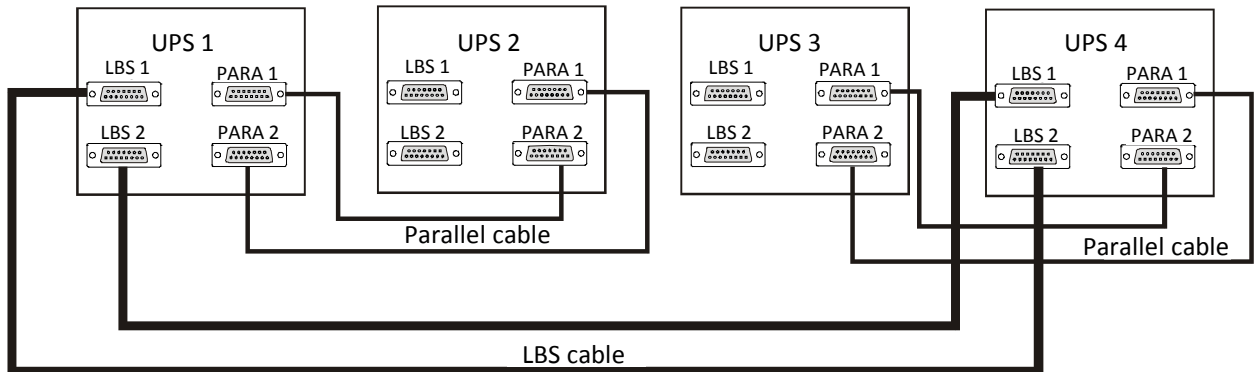

Figure 7-7 Connection of typical LBS system (parallel system)

Chapter 8 Options

This chapter provides the UPS option list, and introduces the functions, installation and configuration of each option.

8.1 Option List

See Table 8-1 for option list of the UPS.

Table 8-1 Option list

No.	Option name	Remark	Model
1	Bypass load sharing inductor kit	Common for 30kVA and 40kVA	NXC 0040kBIS01
2	32-block battery kit	Or select the battery cable and battery tray, battery string is user-prepared	NXC 0040kBTS01
3	38-block battery kit		NXC 0040kBTS02
4	Battery temperature compensation kit	Used together with UF-RS485 card	NXC 0040kBDS01
5	Seismic anchor kit	Common for 30kVA and 40kVA	UHRF3S674Z1
6	Air filter	4 PCS	NXC 0040kAFS01
7	IS-WEBL card	Intellislot ports 1 ~ 3 (Intellislot port 2 recommended)	UF-SNMP810
8	IS-Relay card	Intellislot ports 1 and 3 (Intellislot port 1 recommended)	UF-DRY410
9	IS-485L card	Intellislot ports 1 and 3 (Intellislot port 3 recommended)	UF-MODBUS410
10	BCB box	Used to connect and control the external battery string	NX 0040kJ1AFN02Z18
11	Parallel cable	Available in 5m, 10m, 15m	NX 0040kJ1AFN02SL17 NX 0040kJ1AFN02SL11 NX 0040kJ1AFN02SL12
12	LBS cable	Available in 5m, 10m, 15m	NX 0040kJ1AFN02SL13 NX 0040kJ1AFN02SL14 NX 0040kJ1AFN02SL15
13	C2 electromagnetic shielding assembly		NX 0040kJ1AFN02Z16
14	Output transformer		NX 0040kJ1AFN02Z15
15	Lightning proof plate		NX 0040kJ1AFN02Z17
16	3-in 1-out copper bar kit	Marked with number 21	NXC 0040kTSB01

8.2 Option Introduction

8.2.1 Bypass Load Sharing Inductor Kit

Install the bypass load sharing inductors for the parallel system comprised of two or more UPS modules, to ensure the bypass output load sharing for the parallel system. The bypass load sharing inductor is used to compensate the impedance differentia between SCR and cable. See Table 8-2 for the specifications.

Table 8-2 Specifications of bypass load sharing inductor

UPS (kVA)	Dimensions (H × W × D) (mm)	Inductor value (uH)
30/40	140 × 80 × 90	122

Each UPS cabinet has three bypass load sharing inductors, with no extra clearance occupied. The load sharing rate is generally 10% of the system rated current with the difference of external cable configuration. Try to make the cable length be the same from bypass to each UPS and from UPS module output to parallel system connection point.

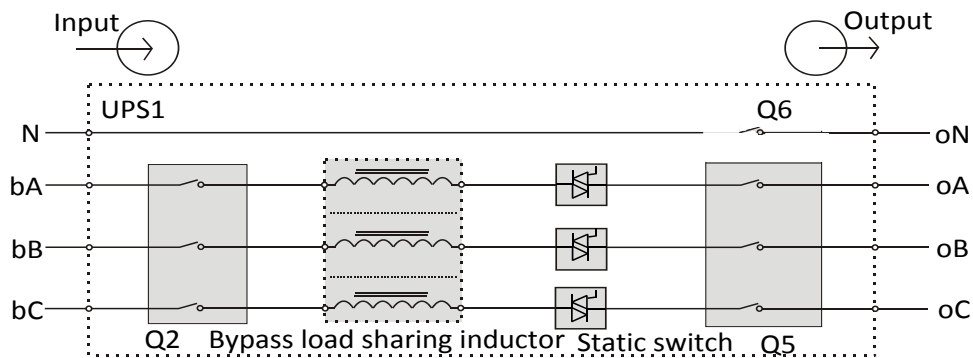

Figure 8-1 Operation principle of bypass load sharing inductor

Preparation

1. Prepare the installation tools, including a cross head screwdriver, a pair of diagonal cutting pliers, a sleeve and an adjustable spanner.
2. Check that all installation materials are present and complete, including three bypass load sharing inductors, 12 M5 × 12 sems screws (for fixing the inductors), six M6 × 16 sems screws (for fixing the power cables), six M6 flat washers and nuts.

Procedures



Warning

1. Only authorized personnel shall install and replace the inductors.
2. Connect the cables strictly following the instructions. Failure to observe this may cause damage to the UPS and the inductors.

1. Shut down the UPS completely.



Note

This procedure will cause the load power-off.

- a) Close the load.

- b) Refer to 5.6.1 *Procedures For Completely Powering Down UPS* for UPS module shutdown, and 7.3.5 *Procedures For Completely Powering Down UPS* for parallel system shutdown.
- c) All the LCDS are off, wait five minutes for the internal DC bus capacitors of the UPS complete discharging.
2. Remove the left side panel of the UPS cabinet, reserve the removed screws.
 3. Install the three bypass load sharing inductors, see Figure 8-2.

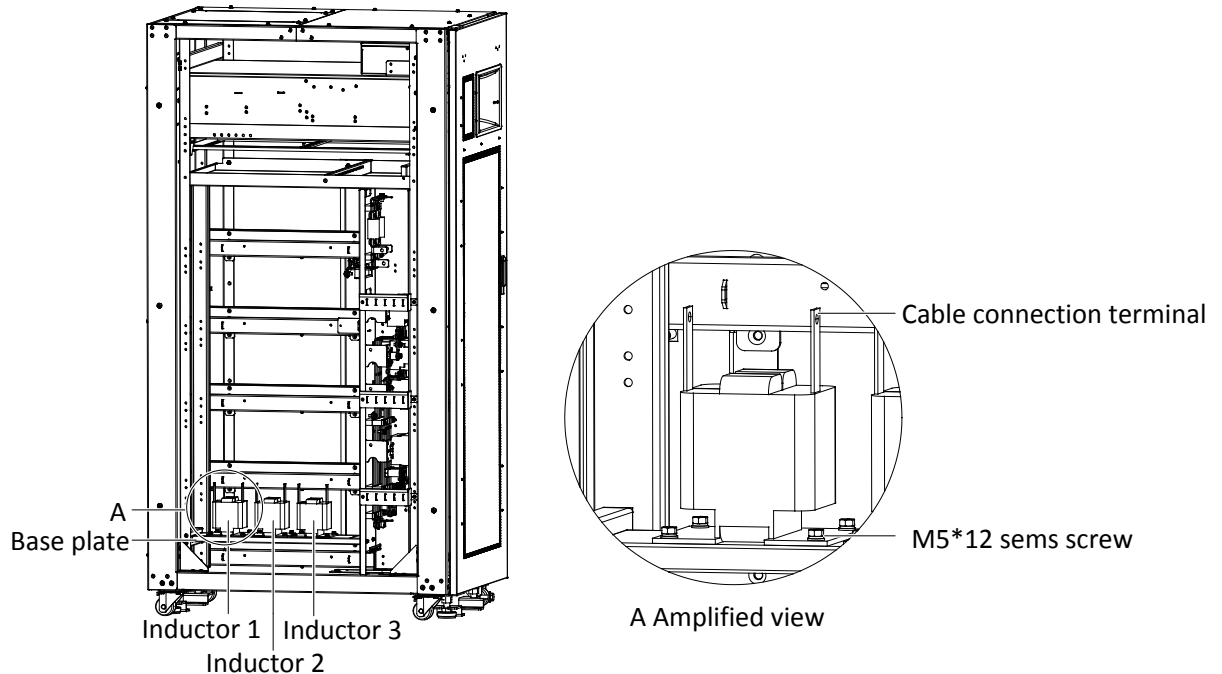

Figure 8-2 Position of bypass load sharing inductors

There are 12 installation holes on the base plate of the UPS cabinet for fixing the three inductors, four installation holes for each inductor. Place the three inductors in the installation positions shown in Figure 8-2, and fix them on the base plate of the UPS cabinet with 12 M5 × 12 sems screws.

4. Connection of bypass load sharing inductors.

If the UPS cabinet has been connected three bypass cables (W26, W27, W28), you should first remove the three cables and follow the procedures below to connect bypass load sharing inductor cables:

- a) First respectively connect one end of W62 and W59 to terminal1 and terminal 2 of inductor 1, and use the M6 × 16 sems screws, M6 flat washers and nuts to fasten the terminals. The torque value is 4.8N.m. Then respectively connect the other end of W62 and W59 to the transfer terminal bC in UPS cabinet and the corresponding cabling hole Q2-6 of bypass input switch Q2. See Figure 8-3 for details.

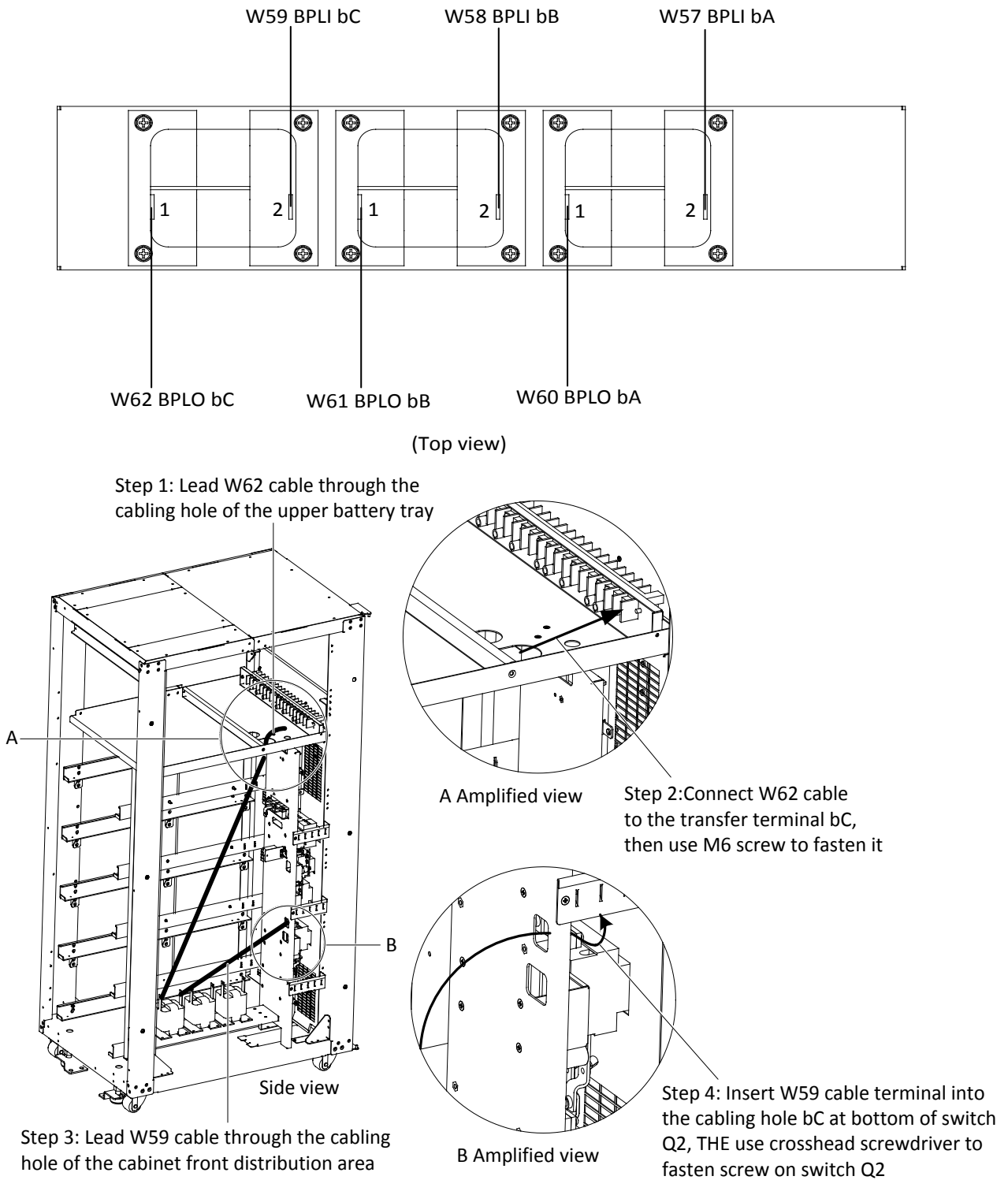

Figure 8-3 Connection of inductor 1

b) Respectively connect one end of W61 and W58 to terminal 1 and terminal 2 of inductor 2, and use the M6 × 16 sems screws, M6 flat washers and nuts to fasten the terminals. The torque value is 4.8N.m. Then respectively connect the other end of W61 and W58 to the transfer terminal bB in UPS cabinet and the corresponding cabling hole Q2-4 of bypass input switch Q2. Refer to inductor 1 for the detailed connection method of inductor 2.

c) Respectively connect one end of W60 and W57 to terminal 1 and terminal 2 of inductor 3, and use the M6 × 16 sems screws, M6 flat washers and nuts to fasten the terminals. The torque value is 4.8N.m. Then respectively connect the other end of W60 and W57 to the transfer terminal bA in UPS cabinet and the

corresponding cabling hole Q2-2 of bypass input switch Q2. Refer to inductor 1 for the detailed connection method of inductor 3.

5. Replace the left side panel and close the front door of the UPS.



Note

Ensure that there are no foreign matters inside the UPS cabinet before closing the door.

Now, the installation and connection of the bypass load sharing inductors are complete.

Maintenance

1. Keep the connections tight. Tighten all connections in installation, and periodically check them.
2. Keep the inductors clean. Maintain the inductors free of dust and moisture.
3. Keep good records. Inform the service engineer for on-site maintenance in time.

8.2.2 Internal Battery Kit

Vertiv provides two kind of internal battery kits for the user when UPS internal battery or corresponding kits is required. Kit A: 32-block internal battery kit (factory installation), or select the battery cable, battery tray, screws, protective cap and battery fuse (site installation); Kit B: 38-block internal battery kit (factory installation), or select the battery cable, battery tray, screws, protective cap and battery fuse (site installation).

Note: For 32-block/38-block internal battery kit (factory installation), Vertiv provides valve-regulated lead acid battery -GP 12340-12V-34.0Ah, see Table 8-3 for its parameters.

Table 8-3 Parameters of valve-regulated lead acid battery -GP 12340-12V-34.0Ah

Dimensions	Overall height (H)	Container height (h)	Length (L)	Width (W)
mm (inch)	178.3±2 (7.02±0.08)	154.8±2 (6.09±0.08)	195.6±2 (7.7±0.08)	130±1.5 (5.12±0.06)

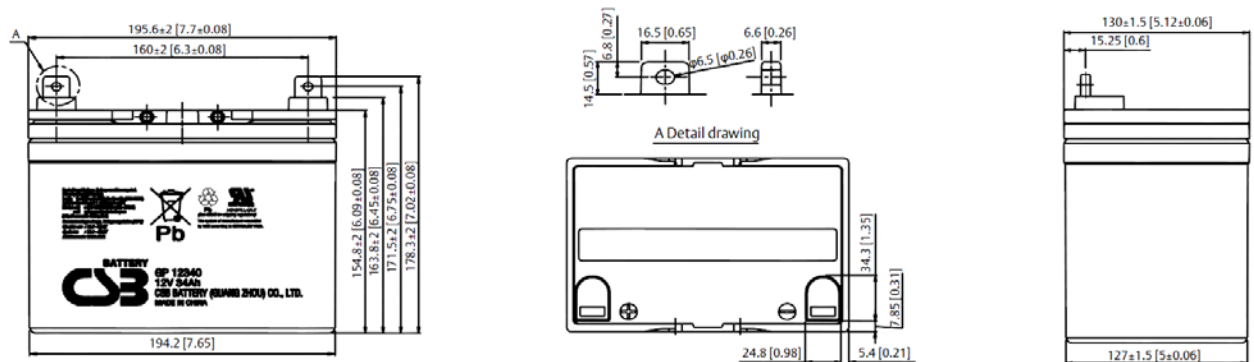

Note

1. There is no battery for 32-block/38-block internal battery kit (site installation).
2. Battery cable, battery tray and protective cap are designed according to the specifications of valve-regulated lead acid battery -GP 12340-12V-34.0Ah. If the customer needs 32-block/38-block internal battery kit for site installation, please purchase battery of the same specification.

Preparation

1. Prepare the installation tools, including a cross head screwdriver, a pair of insulated gloves, a sleeve, an adjustable spanner, and a multimeter.

2. Check that all installation materials are present and complete, including internal battery, four battery trays and corresponding battery power cables (kit A), or five battery trays and corresponding battery power cables (kit B).

Procedures

1. Shut down the UPS completely.

a) Close the load.

b) Refer to 5.6.1 *Procedures For Completely Powering Down UPS* for UPS module shutdown, and 7.3.5 *Procedures For Completely Powering Down UPS* for parallel system shutdown.

c) All the LCDS are off, wait five minutes for the internal DC bus capacitors of the UPS complete discharging.

2. Install the internal battery fuse and the battery cables.

a) Open the cabinet front door, remove cover plate of the switches, and then install the battery fuses on corresponding positions shown in Figure 8-4.

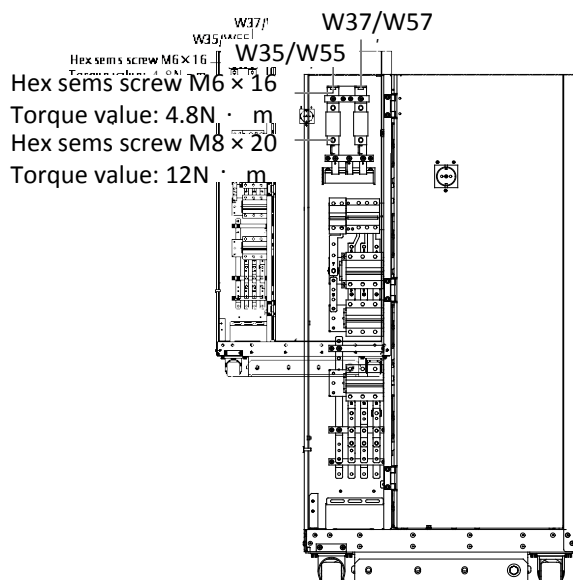

Figure 8-4 Installing internal battery fuse and battery cables (front view)

b) Remove the side panel and back door of the cabinet, and then install W35, W36, W37 (38-block internal battery kit) or W55, W56, W57 (32-block internal battery kit) on corresponding positions according to Figure 8-4 and Figure 8-5.

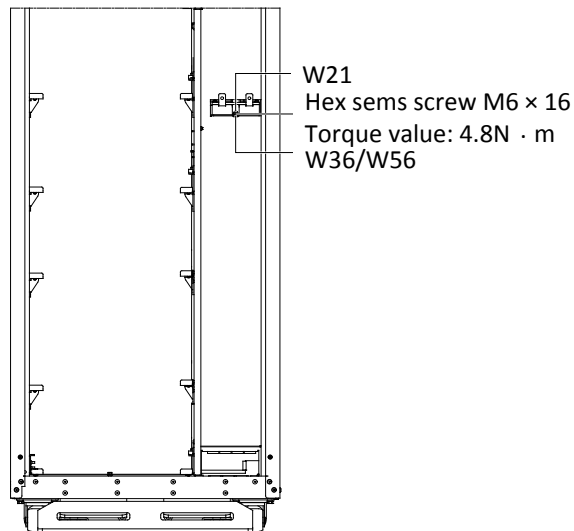

Figure 8-5 Installing battery cables (rear view)

3. Open the cabinet front door, remove the screws to open the battery compartment door (see Figure 8-6), and reserve the removed screws.

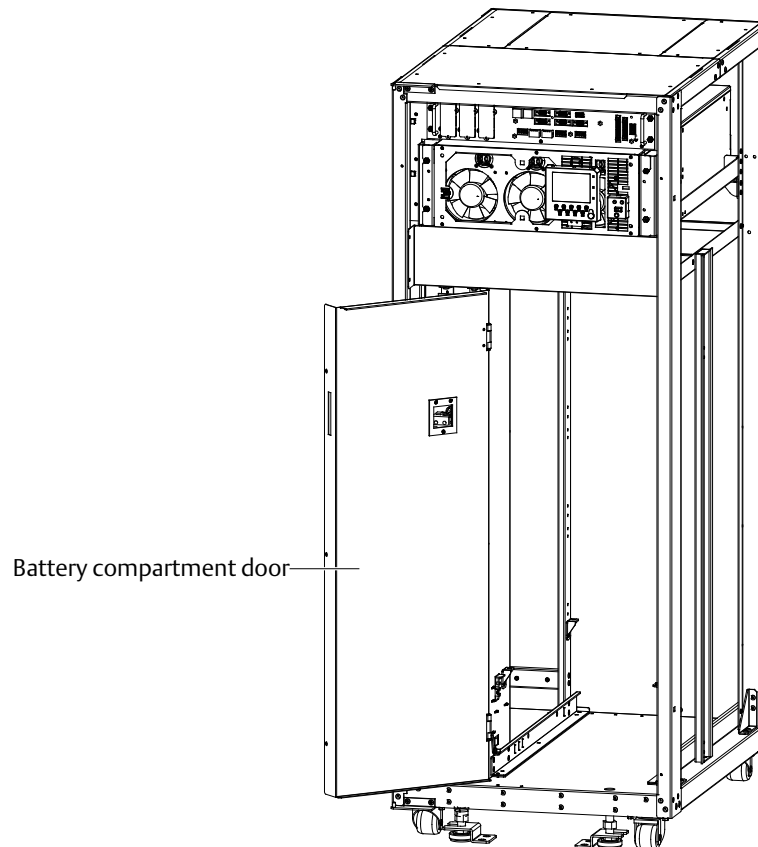

Figure 8-6 Opening battery compartment door



Warning

The following operations of battery and battery tray shall be operated by authorized service engineer with insulated gloves worn.

4. Place the battery into corresponding position in battery tray one by one according to internal battery connection shown in Figure 6-1, and then use M6*20 sems screws/spring washers/flat washers and

battery cables to fix the battery terminals, torque value is 4.8N.m. Note that the protective caps should be added onto the battery terminals (red for +, black for -).

Use straps to place all the batteries into battery trays. Note that the straps must pass across the waist type holes at both sides of the battery tray, and each battery tray needs four straps. Then lead the connection terminals between battery trays. As shown in Figure 8-7. Use the multimeter to measure voltages between connection terminals, so as to verify that the cable connection is correct.

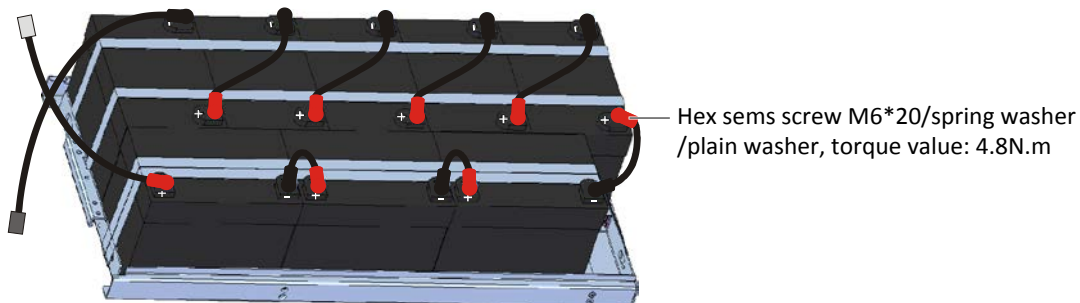



Figure 8-7 Placing the battery into battery tray

5. According to Figure 8-8, insert the trays with batteries installed into the battery compartment one by one, and ensure the No.1 ~ No.5 battery trays correspond to No.1 ~ No.5 layers (from top to bottom) of the battery compartment, otherwise the battery voltage may be abnormal.

		Warning
The battery tray shall be installed from the bottom layer upwards, to avoid falling over caused by high gravity center.		

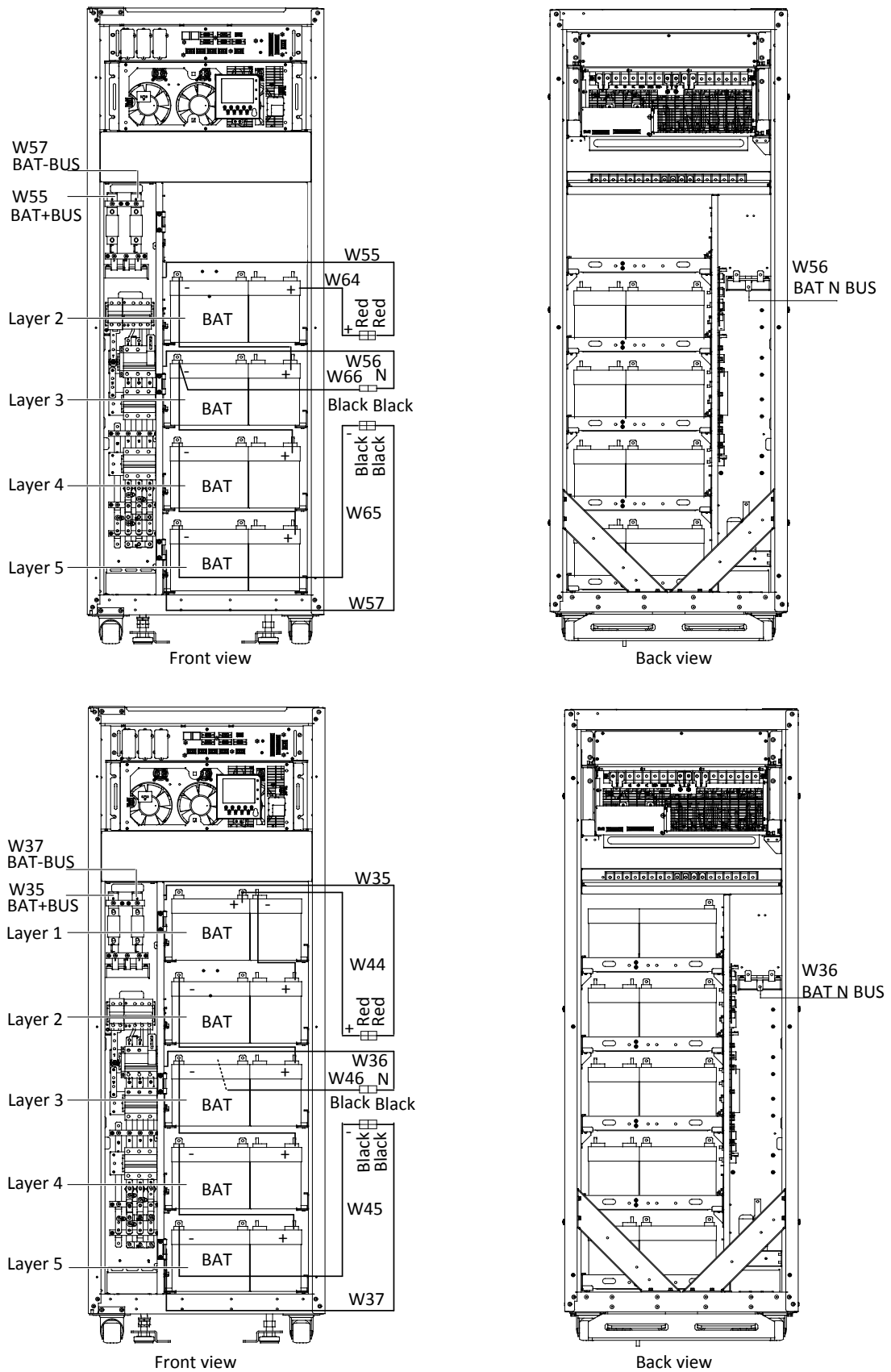

Figure 8-8 Connection between battery trays and batteries

6. Use torque value in Figure 8-9 to fix both sides of the battery tray, then pull up the limiting baffle plate.

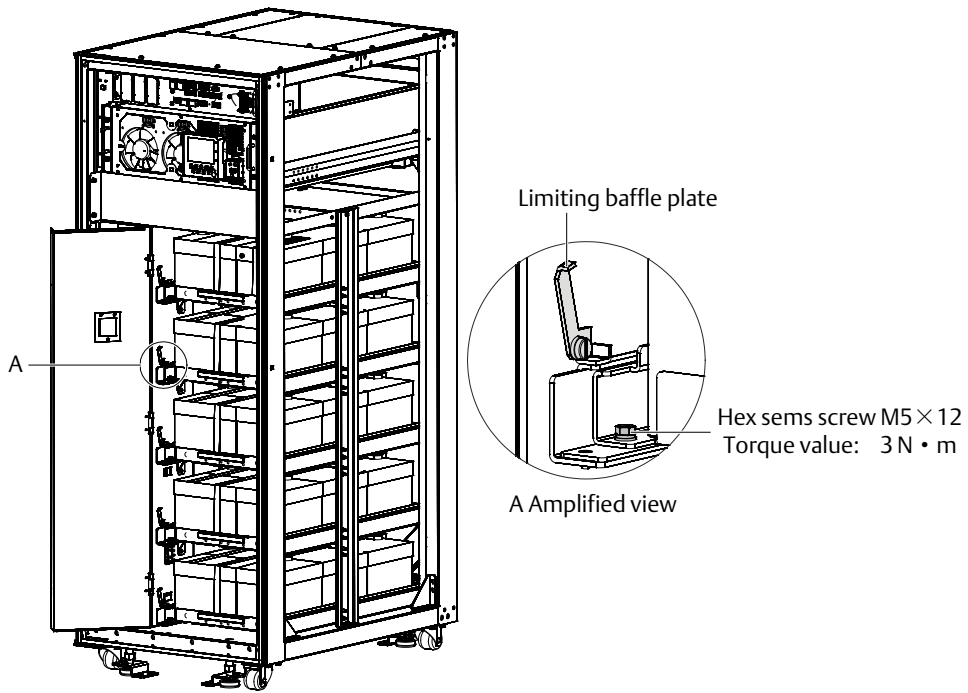

Figure 8-9 Fixing battery tray

7. Use hex sems screw M5*12 (8 pcs) to fix the column reinforcement (2 pcs) at rear of the cabinet.

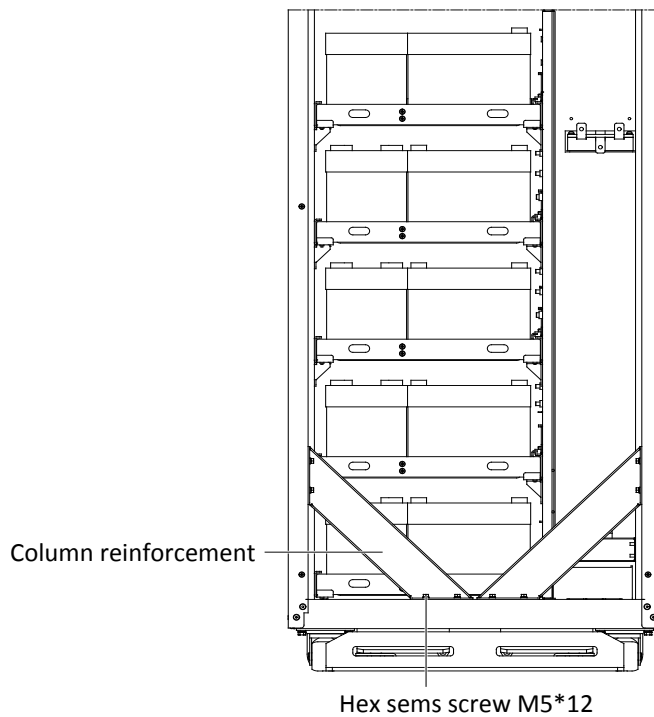

Figure 8-10 Installing column reinforcement (rear view)

8. According to Figure 8-8, connect the positive terminal of battery tray 1 to cabinet positive terminal; connect the neutral line terminal of battery tray 3 to cabinet neutral line terminal, and connect the negative terminal of battery tray 5 to cabinet negative terminal. Use the multimeter to measure voltages between battery terminals (+, -, N), so as to verify that the cable connection is correct.



Warning

At this moment, the battery voltage over 384V has been input to the UPS cabinet. Insulated gloves and other protective measures are required.

9. Close the battery compartment door and then reinstall the switch cover plate, and then use hex sems screw M5*12 (4 pcs) to fasten the column reinforcement on lower left corner of the cabinet, see Figure 8-11.

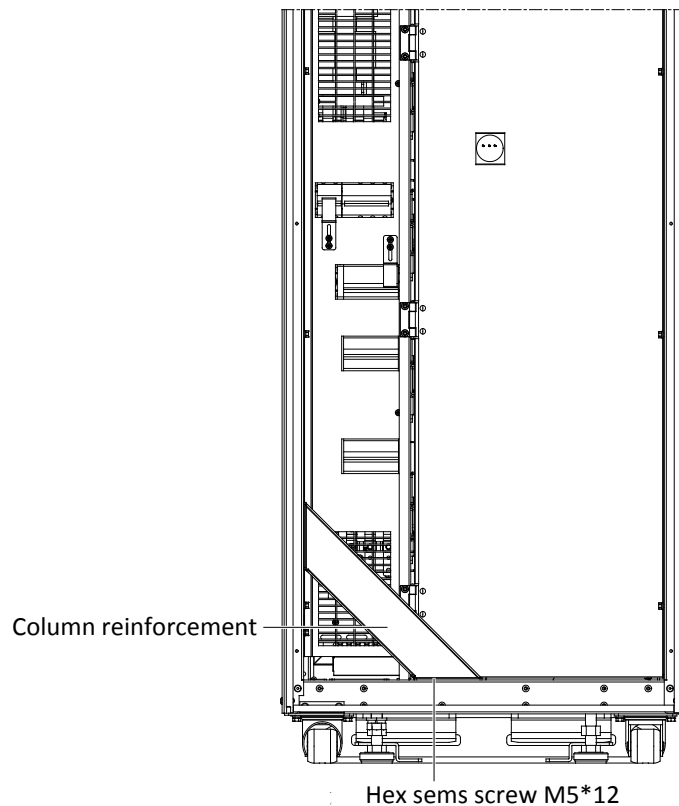

Figure 8-11 Installing column reinforcement (front view)

10. Reinstall the side panel and back door of the cabinet, then close the front door.
For more information of the battery, refer to *Chapter 6 Battery*.

8.2.3 Battery Temperature Compensation Kit

A battery temperature sensor is used to measure the battery temperature. The battery temperature is installed next to the battery for measuring battery temperature. The sensor signal output cable is connected to the UF-RS485 card of Intellislot 1 port. At this moment, the temperature sensor is connected with the UPS internal logic circuit.

With this feature fitted, the nominal float voltage supplied to the battery is adjusted so as to be inversely proportional to the ambient temperature of the battery cabinet or battery room. This prevents the battery being over charged at high ambient temperatures.

Preparation

1. Prepare the installation tools, including a cross head screwdriver.
2. Check that all installation materials are present and complete, including a battery temperature sensor, a UF-RS485 card.

Procedures



1. Connect the cables strictly following the instructions. Failure to observe this may cause damage to the UPS and the battery.
2. Shut down the UPS when installing the battery temperature sensor. During installation, do not touch the battery terminals, bared copper bars and components.

1. Shut down the UPS completely.
 - a) Close the load.
 - b) Refer to 5.6.1 *Procedures For Completely Powering Down UPS* for single UPS module shutdown, and 7.3.5 *Procedures For Completely Powering Down UPS* for parallel system shutdown.
 - c) All the LCDs are off, wait five minutes for the internal DC bus capacitors of the UPS complete discharging.
2. Connect one end of the specified cable to either port of the battery temperature sensor, and the other end to each port of UF-RS485 card. See Figure 8-12.



Figure 8-12 Connection between UF-RS485 card and battery temperature sensor

3. According to Figure 8-13, dial the DIP switch 5 to 'ON', making the lower left corner of the LCD screen of temperature sensor display 01 (or 02). If two temperature sensors are used together, their DIP switches are not allowed to be superposition.



Figure 8-13 DIP switch of temperature sensor

4. Remove the right side panel of the cabinet, place the battery temperature sensor onto the back area of the battery tray 1, and then insert the UF-RS485 card into the Intellislot port 1. The installation method of the UF-RS485 card is the same as that of the IS-WEBL card described in 8.2.6 *IS-WEBL card*. Refer to Figure 8-14 for installation and connection of the battery temperature sensor.

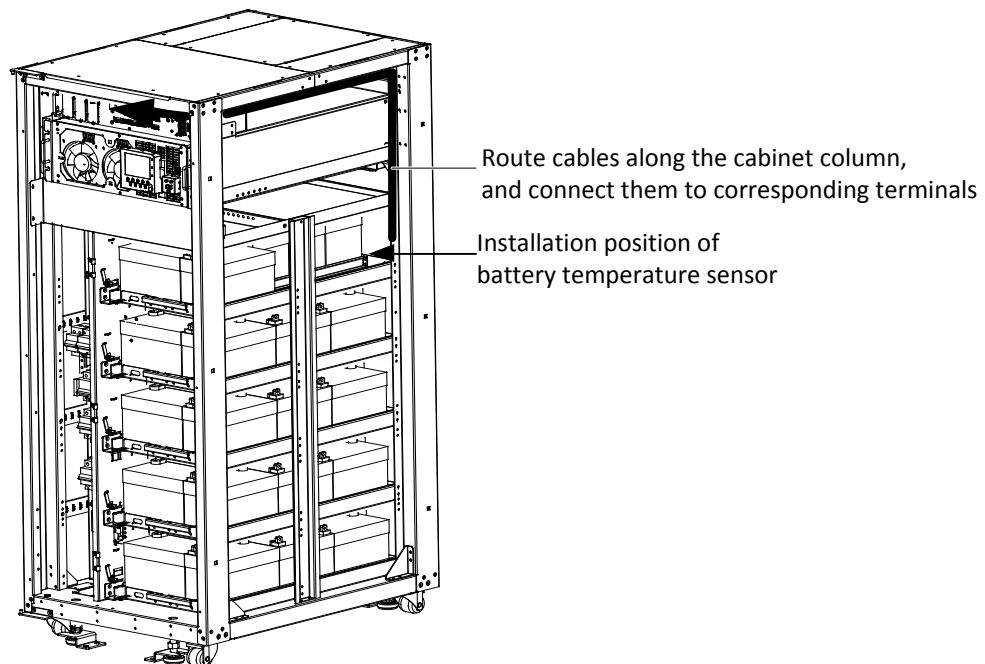

Figure 8-14 Installation and connection of battery temperature sensor

5. Wiring according to Figure 8-8, pack the cables in order. Note that the cables should be routed separately from the power cables, to avoid EMI.

8.2.4 Seismic Anchor Kit

The UPS provides seismic anchor kits to avoid and reduce the damage to UPS caused by earthquake or vibration.

See Table 8-4 for dimensions of the seismic anchor kits.

Table 8-4 Dimensions of the seismic anchor kits

UPS (kVA)	Width (mm)	Length (mm)
30/40	55	375

After fixing the UPS onto the concrete floor, the seismic anchor kits should achieve Class 2 requirement of Table 2 in IEC60068.3.3 and satisfy the UBC 1994 standard (earthquake area 4 from fierceness to very fierceness).



Warning

1. Only Vertiv-authorized engineers shall carry out the installation.
2. Carry out the installation strictly following the instructions. Failure to observe this could cause personnel injury or damage to the UPS and seismic anchor kits.

Preparation

1. Prepare the installation tools, including a cross head screwdriver, a torque spanner and an adjustable spanner.
2. Check that all installation materials are present and complete, including five seismic anchors, four M10 × 30 sems screws, eight M16 × 50 sems screws, eight M12 expansion bolts.

Procedures

The installation procedures are as follows:

1. Lift up the UPS cabinet and remove the four adjustable feet on the bottom, as shown in Figure 8-15.

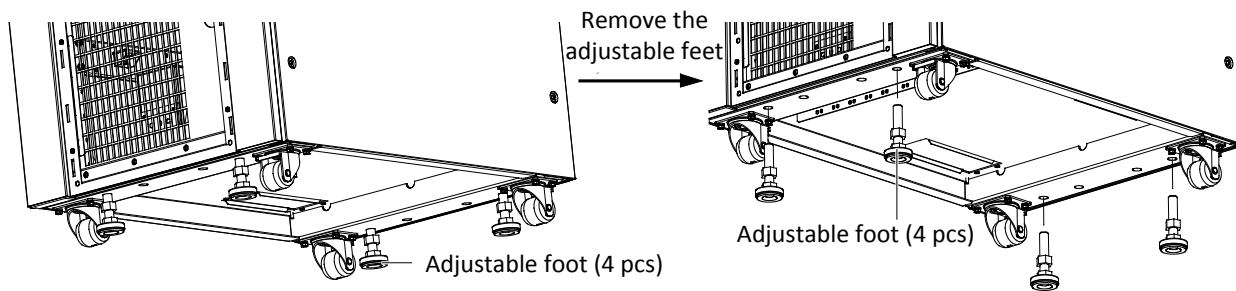

Figure 8-15 Removing adjustable feet

2. Use four M16 × 50 sems screws to install seismic anchor 1 and seismic anchor 2 on the rear bottom of the UPS cabinet, as shown in Figure 8-16.

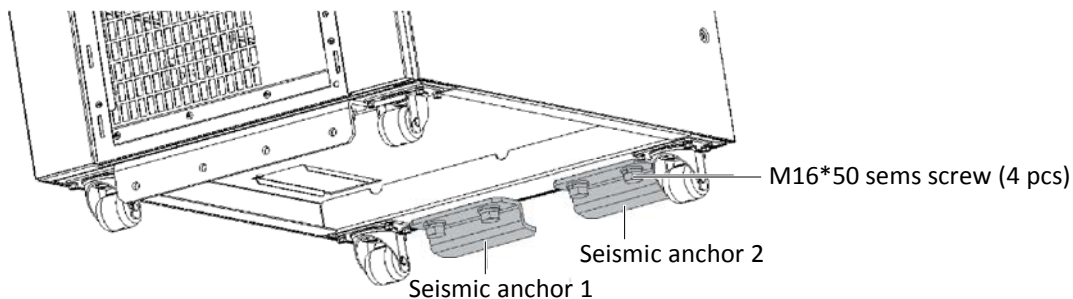

Figure 8-16 Installing seismic anchor 1 and seismic anchor 2

3. Use four M16 × 50 sems screws to install seismic anchor 3 on the front bottom of the UPS cabinet, as shown in Figure 8-17; then carefully place the UPS cabinet on the ground.

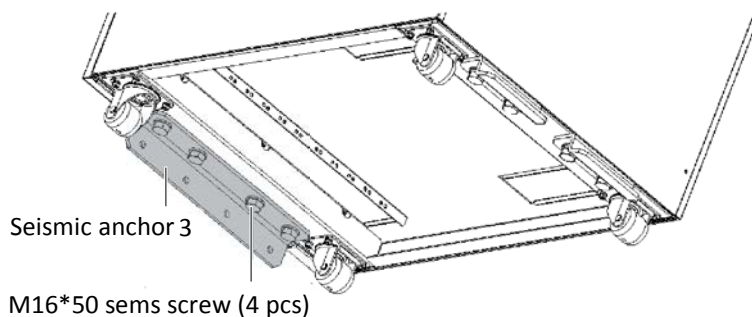

Figure 8-17 Installing seismic anchor 3

4. As shown in Figure 8-18, use four M12 expansion bolts to fix seismic anchor 4 on the ground, then push the UPS backward to insert seismic anchor 1 and seismic anchor 2 into the two holes of seismic anchor 4 respectively.

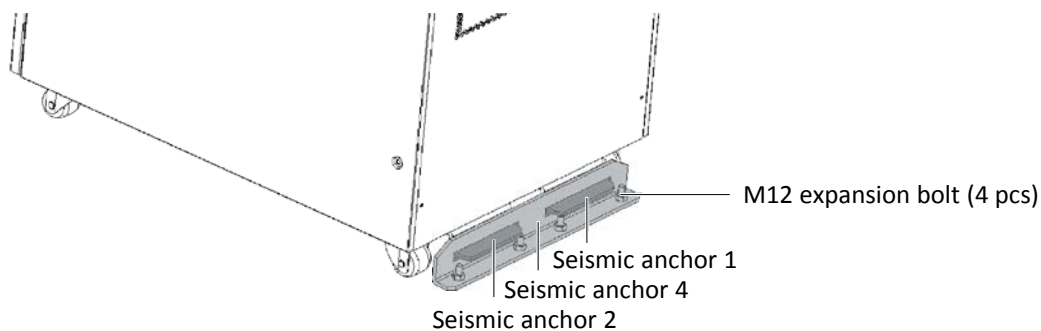

Figure 8-18 Fixing seismic anchor 4 on the ground and fixing the cabinet

5. Use four M10 × 30 sems screws to fix seismic anchor 5 onto seismic anchor 3, as shown in Figure 8-19.

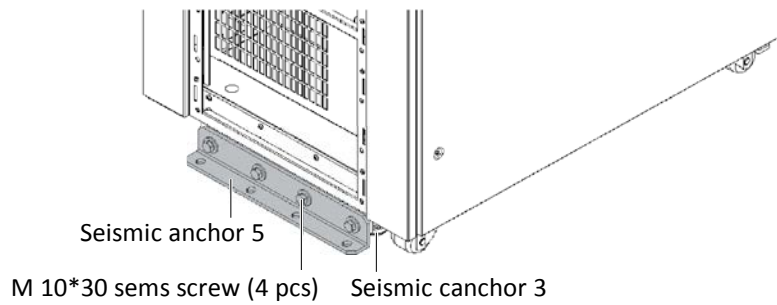

Figure 8-19 Fixing seismic anchor 5 onto seismic anchor 3

6. Use four M12 expansion bolts to fix seismic anchor 5 on the ground, as shown in Figure 8-20.

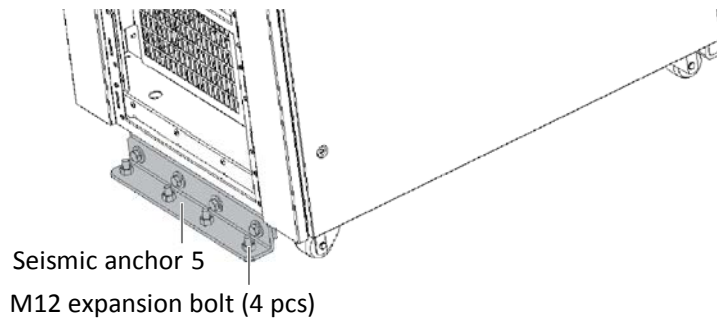

Figure 8-20 Fixing seismic anchor 5 on the ground

8.2.5 Air Filter

The air filters need regular inspection and replacement. The inspection and replacement intervals are related to the environmental conditions of the UPS. See Table 8-4 for dimensions of the four air filters. The life parameters and recommended replacement time of the air filter is listed in Table 10-1, and the replacement method of the air filter is shown in 10.2.2 Replacement Of Air Filter.

Table 8-5 Dimensions of air filter

UPS (kVA)	Dimension (L × W) (mm)	PCS
30/40	455 × 376	3
30/40	200 × 152	1

8.2.6 IS-WEBL Card

Figure 8-21 shows the appearance of the IS-WEBL card.

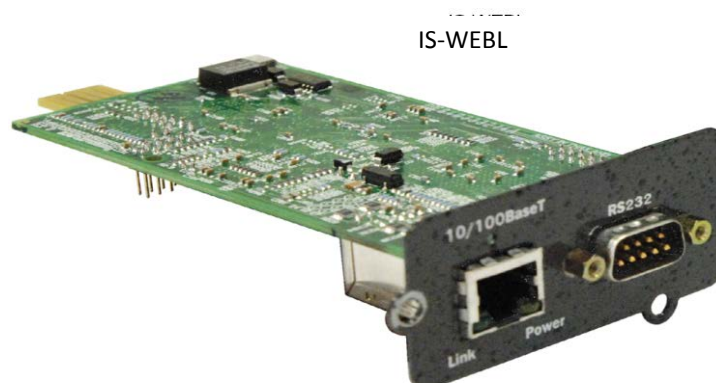

Figure 8-21 IS-WEBL card

The IS-WEBL card is a network management card. It can make the UPS made by Vertiv Tech Co., Ltd real network equipment. It can also be connected to the IRM series sensor to provide environment monitoring function. When the intelligent equipment generates an alarm, the IS-WEBL card can notify the user by recording the log, sending trap information, and sending a mail.

Preparation

1. Prepare the installation tools, including a cross head screwdriver.
2. Check that all installation materials are present and complete, including an IS-WEBL card.

Procedures



Note

There is no need to shut down the UPS during IS-WEBL card installation, because the IS-WEBL card is hot pluggable.



Warning

Some electron components in IS-WEBL card are sensitive to static, therefore, do not touch the electron components or circuit in IS-WEBL card by hand or other conductive materials, so as to protect the IS-WEBL card against static shock. When removing or installing the IS-WEBL card, hold the card side edge to operate it.

The IS-WEBL card should be installed in the Intellislot port (see Figure 3-7) in the UPS. See Table 3-10 for installation positions of optional cards.

Method for installation:

1. Remove the cover of Intellislot port. Note to reserve the removed screws and take care of the cover for future use.
2. Insert the IS-WEBL card (along two sides of the Intellislot port) into the port position recommended in Table 3-10, and then fasten the screws.

For more information of the IS-WEBL card, refer to the *Liebert IntelliSlot Web Card Quick Start Guide* in accessory.

Refer to 3.2.11 *Signal Cable Connection Steps* for the cabling and routing of the signal cables.

8.2.7 IS-Relay Card

Figure 8-22 shows the appearance of the IS-Relay card.



Figure 8-22 IS-Relay card

The UPS provides IS-Relay card for the user to use the dry contact signal to monitor the UPS. The functions of the IS-Relay card are listed in Table 8-6.

Table 8-6 Function of UPS IS-Relay card

Pin	Function	Operation
1	Common-Low Battery	
2	Low Battery	Closed if low battery point occurs
3	Low Battery	Closed if battery is OK
4	Common-UPS Fault	
5	UPS Fault	Closed if UPS fault occurs
6	UPS Fault	Closed if no UPS failure
7	Common-On Battery	
8	On Battery	Closed if On Battery power (Utility failure)
9	On Battery	Closed if not On Battery power (Utility OK)
10	Signal Ground	Use for UPS Any-Mode Shutdown
11	Signal Ground	Use for UPS Any-Mode Shutdown
12	UPS Any-Mode Shutdown	Turn UPS output Off when shorted to Pin 10 or 11
13	Summary Alarm*	Closed if no alarm conditions are present
14	Summary Alarm*	Closed if Summary Alarm occurs
15	Common-Summary Alarm*	
16	On UPS	Closed if On UPS (inverter) power
17	On Bypass	Closed if On Bypass
18	Common-On Bypass	

For more information of the IS-Relay card, refer to the *Liebert IntelliSlot Relay Card User Manual* in accessory.

The installation method of the IS-Relay card is the same as that of the IS-WEBL card described in 8.2.6 *IS-WEBL card*. Refer to 3.2.11 *Signal Cable Connection Steps* for the cabling and routing of the signal cables.

8.2.8 IS-485L Card

Figure 8-23 shows the appearance of the IS-485L card.



Figure 8-23 IS-485L card

The IS-485L card can realize the conversion from UPS internal protocol to Modbus RTU protocol, so the user can use the Modbus RTU protocol to manage the UPS, acquire the UPS parameters, operating status and fault types to achieve UPS monitoring.

For more information of the IS-485L card, refer to the *Liebert IntelliSlot Modbus 485, Modbus IP And BACnet IP Reference Guide* in accessory.

The installation method of the IS-485L card is the same as that of the IS-WEBL card described in 8.2.6 *IS-WEBL card*. Refer to 3.2.11 *Signal Cable Connection Steps* for the cabling and routing of the signal cables.

8.2.9 BCB Box

Refer to 6.9 *BCB Box* for more information about the specifications, battery connection of the BCB box.

8.2.10 C2 Electromagnetic Shielding Assembly

With the C2 electromagnetic shielding assembly fitted, this UPS is a Class C2 UPS product for residential environment. Installation restrictions or additional measures may be needed to prevent disturbances.

C2 electromagnetic shielding assembly for 30kVA and 40kVA UPS are installed in factory.

8.2.11 Output Transformer

This UPS includes an isolation transformer (see Figure 8-24 for its position) at the UPS output. This transformer is installed in the cabinet and provides electrical isolation between the UPS output and the load.

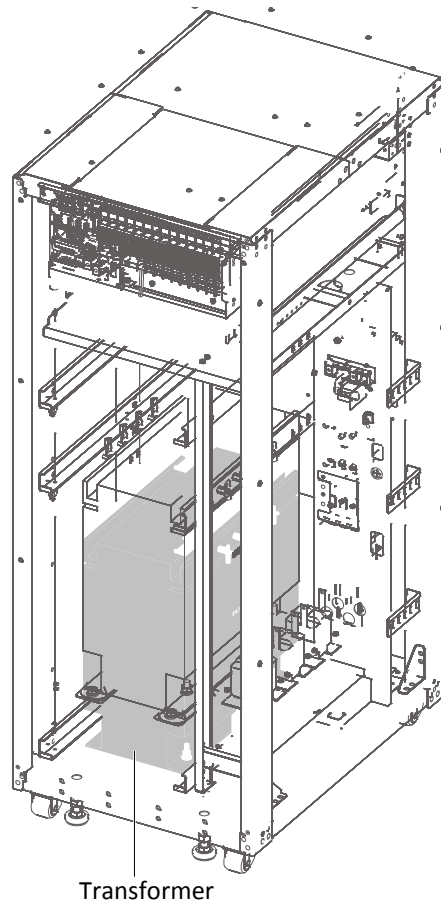

Figure 8-24 Output transformer

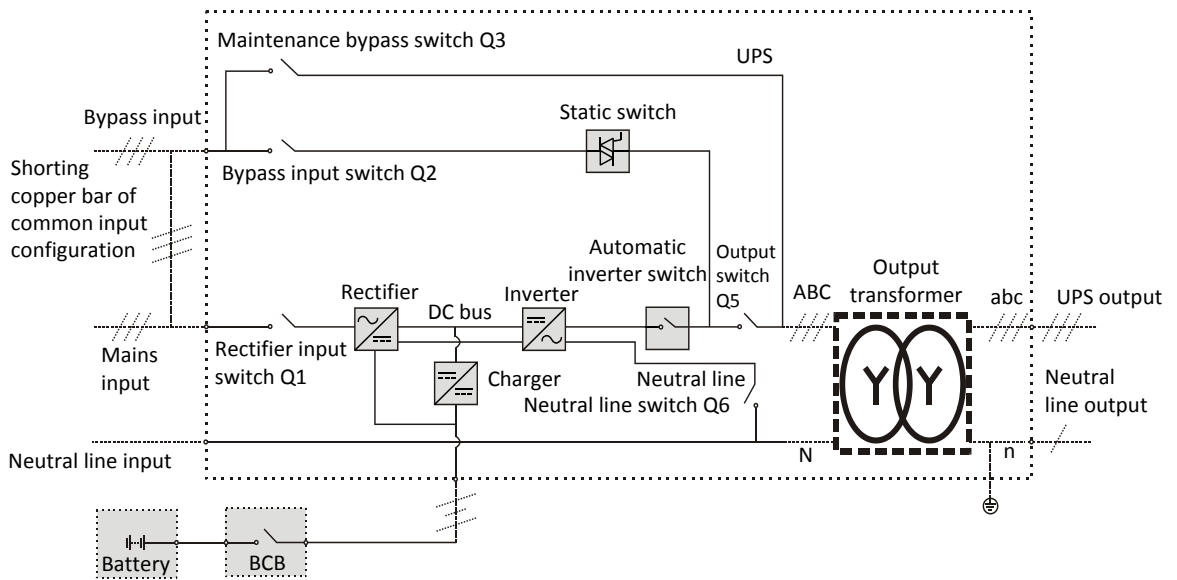

Figure 8-25 System working principle (output transformer included)

  **Warning**

1. The optional output transformer is only suitable for 3-in 3-out mode.
2. When switching on the maintenance bypass switch, the output transformer is still live. During the transformer maintenance, you must shut down the UPS completely.

Mechanical specification

See Table 8-7 for specification of the output transformer.



Table 8-7 Specifications of output transformer

Output transformer	Dimensions (H × W × D) (mm)	Weight (kg)
30/40kVA	505 × 270 × 488	200

Preparation

1. Prepare the installation tools, including a cross head screwdriver, a pair of diagonal cutting pliers, a sleeve and an adjustable spanner.
2. Check that all installation materials are present and complete, including an output transformer, three sets of cable, a signal acquisition device, an RS485 card, eight M8 × 20 bolts/flat washers/nuts (for fixing the metal plates), four M12 nuts/flat washers/spring washers (for fixing the output transformer), eight M6 hexagon sems screws/flat washers/nuts (for fixing the transformer copper bars and connecting cables), two M6 hexagon sems screws (rack-provided, for fixing the transformer output neutral line), four M4 × 20 sems screws/flat washers/nuts (rack-provided, for fixing the fan cover), ten M5 × 10 sems screws (rack-provided, for fixing the fan structural parts), and a wire guard, 15 wire covers (to prevent the signal cables being cut).

Procedures

 Warning
<ol style="list-style-type: none"> 1. Only authorized personnel shall install and replace the output transformer. 2. Connect the cables strictly following the instructions. Failure to observe this may cause damage to the UPS and the output transformer.
<ol style="list-style-type: none"> 1. Shut down the UPS completely.
 Note
<p>This procedure will cause the load power-off.</p>

- a) Close the load.
 - b) Refer to 5.6.1 *Procedures For Completely Powering Down UPS* for UPS module shutdown, and 7.3.5 *Procedures For Completely Powering Down UPS* for parallel system shutdown.
 - c) All the LCDS are off, wait five minutes for the internal DC bus capacitors of the UPS complete discharging.
2. Remove the rear panel and side panels of the UPS cabinet, and reserve the removed screws.
 3. Install the output transformer.
 - a) According to Figure 8-26, remove the four battery tray beams, three shorting copper bars (number 51) and cable W31.

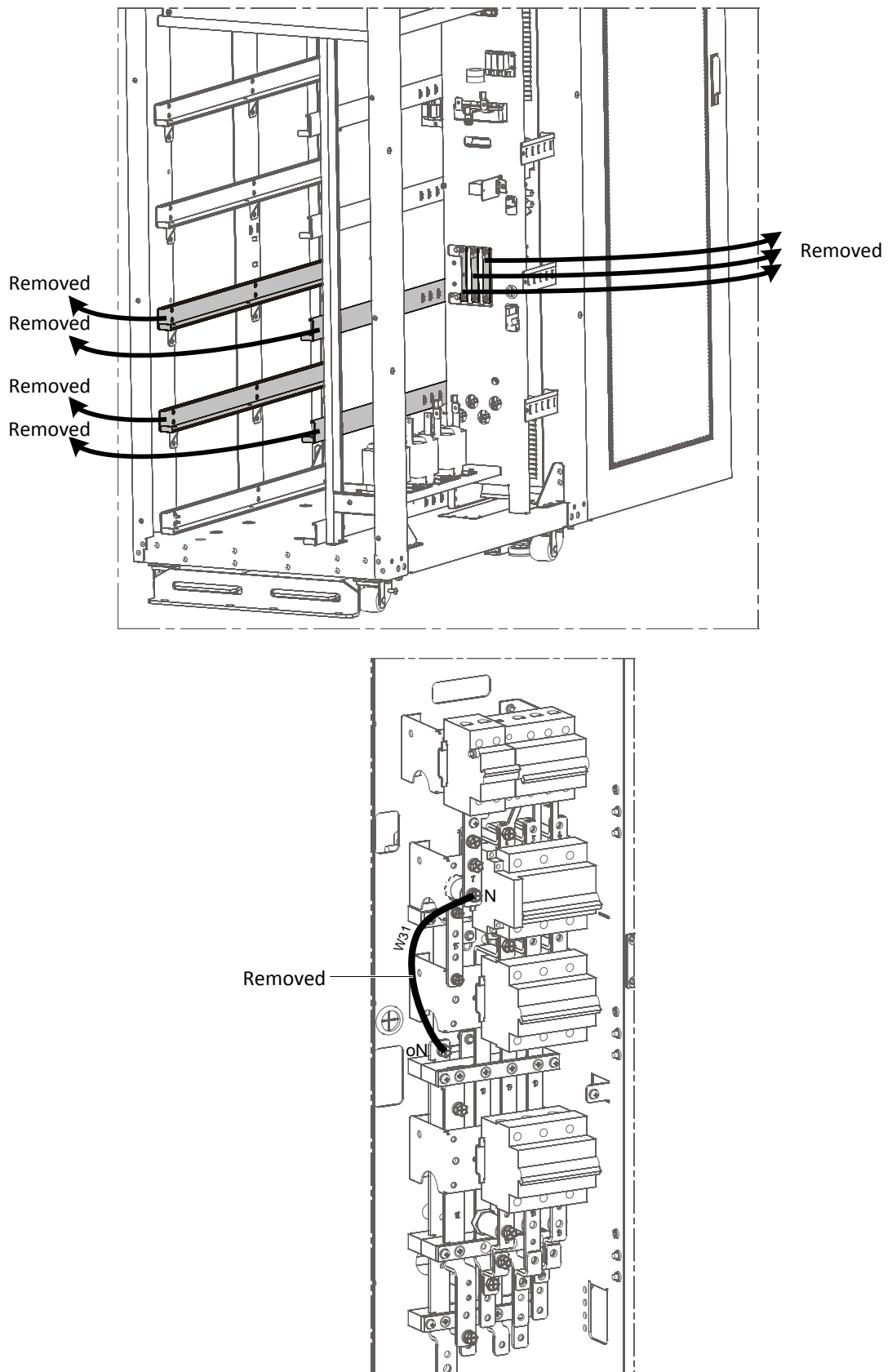

Figure 8-26 Removing battery tray beams, shorting copper bars and cable W31

b) Install the metal plates and cushion pads onto the base, as shown in Figure 8-27.

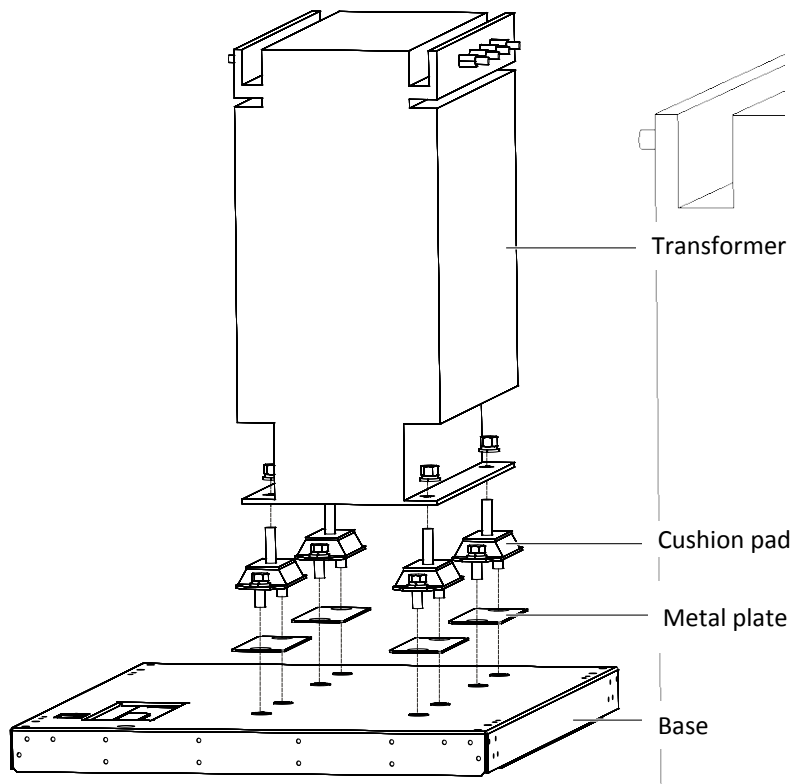

Figure 8-27 Installing output transformer (1)

c) Use the forklift or small crane to place the output transformer into the rack, and then fix it through the cushion pads, and the torque value is 39N.m. Connect one end of the cable W14 to magnetic core of the output transformer, and the other end to the enclosure. As shown in Figure 8-28.

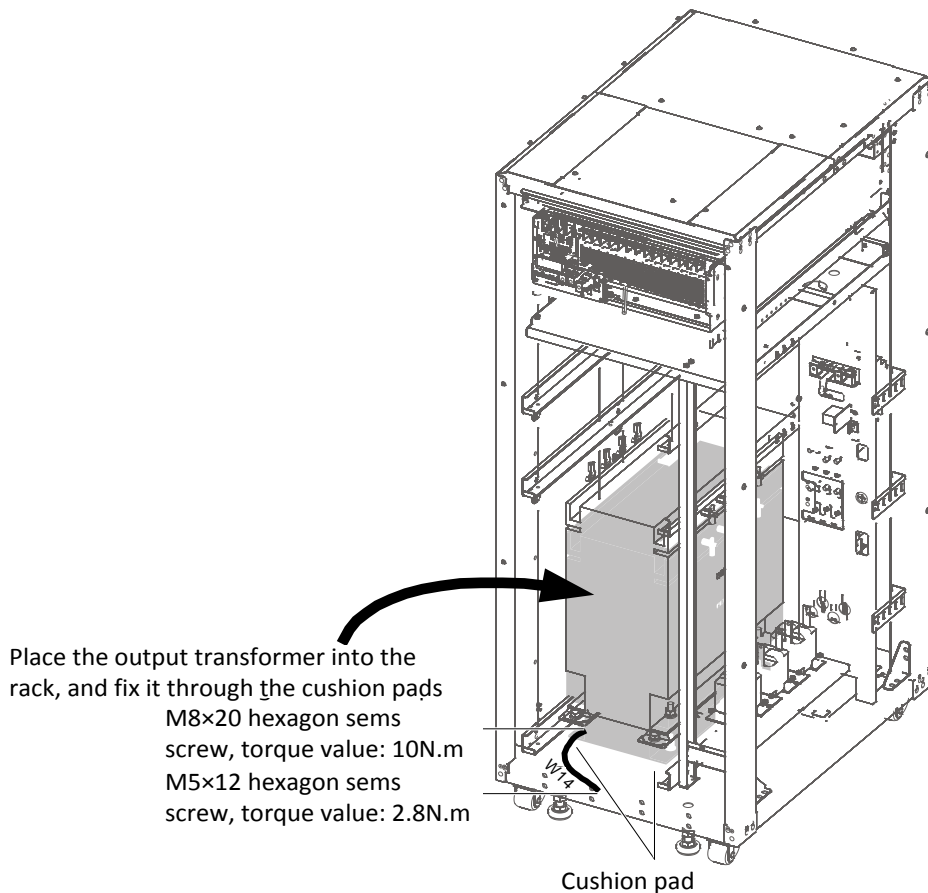
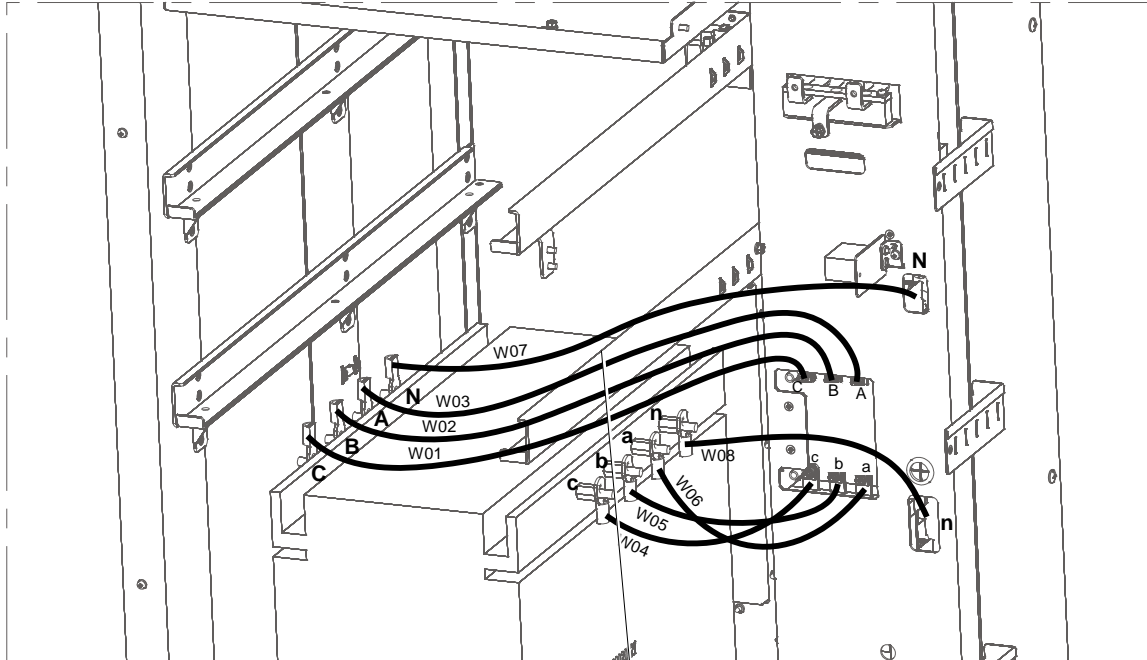

Figure 8-28 Installing output transformer (2)

4. Connect the output transformer cables.

According to Figure 8-29, use cables to connect the terminals (N-A-B-C) of output transformer primary side and the terminals (n-a-b-c) of output transformer secondary side to the corresponding terminals on the rack. For M6 screws, the torque value is 4.5N.m; for M5 screws, the torque value is 2.8N.m. To protect the cables, a wire guard should be added onto the guide rail.



Add wire guard to edge of the guide rail

Figure 8-29 Connection

5. Install the fan.

a) Install the fans onto the front panel of battery cabinet.

b) Connect the cables from the two fans respectively to terminals (N-A) of the output transformer primary side and terminals (N-B) of the output transformer primary side, see Figure 8-30.

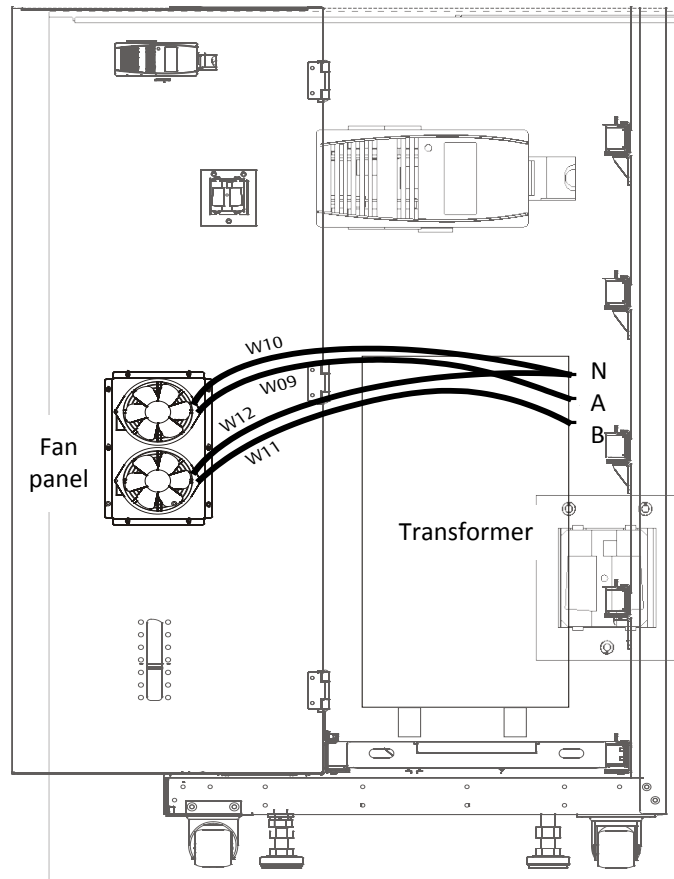

Figure 8-30 Installing fans

6. Install the temperature signal acquisition device.

a) Install the signal acquisition device onto the front panel of battery cabinet, and then fasten it through the cable tie.

b) According to the upper diagram in Figure 8-31, dial the DIP switch 4 to 'ON', making the lower left corner of the LCD screen of signal acquisition device displays 10. Connect one end of the signal cable (W15) to the Door1/DI 1 port of signal acquisition device, and the other end to the temperature control terminal of output transformer; connect one end of the signal cable (W01) to the port of signal acquisition device, and the other end to the RS485 card, see the lower diagram in Figure 8-31.

c) Insert the RS485 card into the Intellislot 1.



Connect the RS485
Card in the Intellislot 1

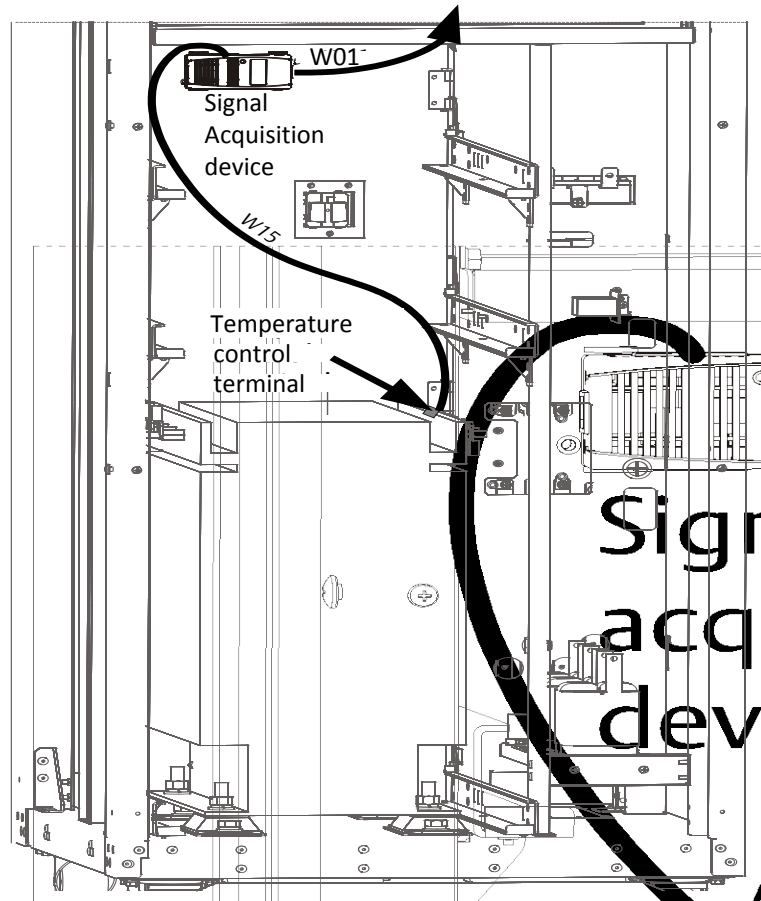

Figure 8-31 Installing signal acquisition device

7. Install copper earth bar of the UPS output neutral line.

The copper bar of the UPS output neutral line is connected with neutral line of the transformer secondary side. Connect one end of the copper earth bar (number 80, see Figure 8-32) to copper bar of the UPS output neutral line, and the other end to the UPS enclosure. Torque value is 4.5N.m.

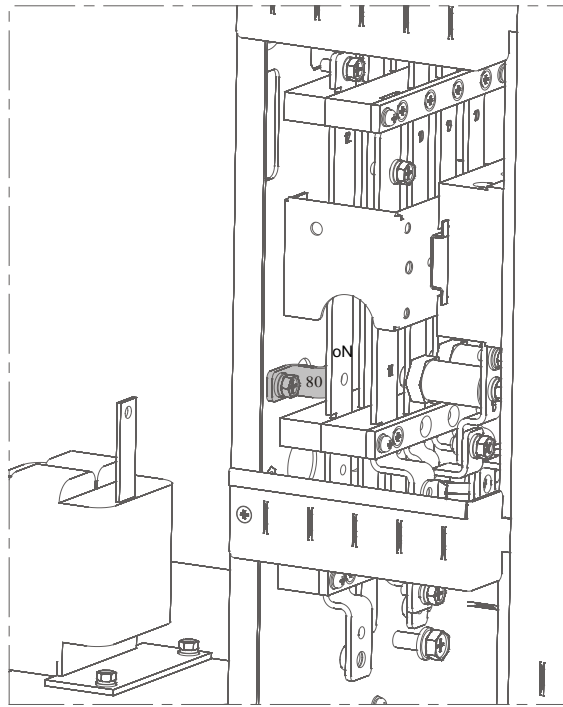

Figure 8-32 Copper earth bar

8. After installation and connection, system with output transformer mode can be set under EPO mode via setting software by the Vertiv authorized personnel.

8.2.12 Lightning Proof Plate

The lightning proof plate (see Figure 8-33 for its position) is installed at the UPS input. The system with lightning proof plate can pass the lightning proof test of 3kA.

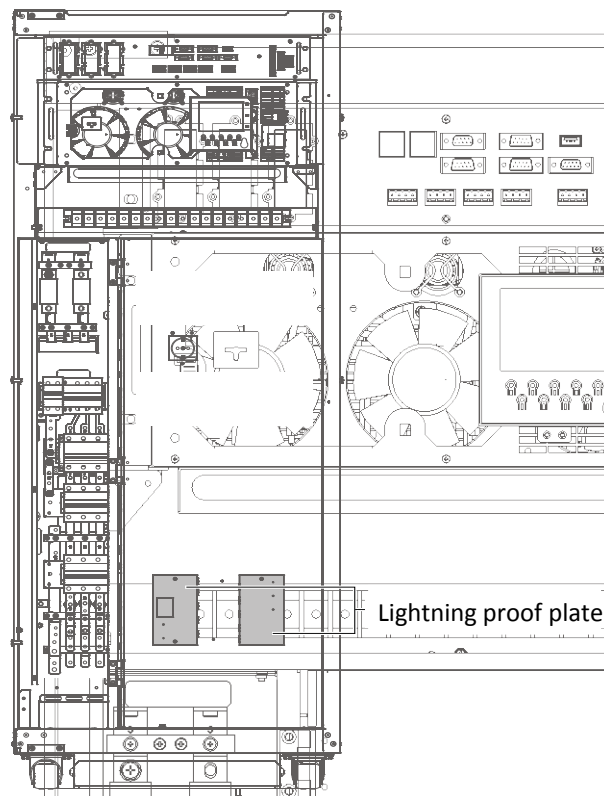

Figure 8-33 Lightning proof plate

8.2.13 3-in 1-out Copper Bar Kit

If this kit is selected, the system can be set to 3-in 1-out mode. Two copper bars (number 21, see Figure 8-34) in this kit are used to connect the bypass input, and output.

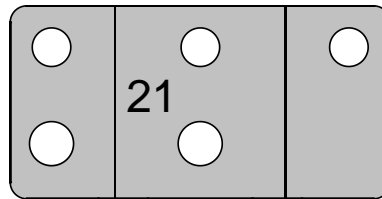

Figure 8-34 3-in 1-out copper bar



Note

UPS is the 3-in 3-out mode by default. If you need to change it into 3-in 1-out mode, contact Vertiv authorized personnel for settings.

Always observe the following procedures:

Power distribution mode

1. 3-in 1-out, common source configuration

(1) Remove the three shorting copper bars (number 14) from the rectifier input terminals mB and mC (mA reserved), see left diagram in Figure 8-35. Use 3-in 1-out copper bars (number 21) to connect the output terminals (oA-oB-oC), and then connect the bypass input terminals (bA-bB-bC), see right diagram in Figure 8-35.

(2) Connect the rectifier input cables to rectifier input terminals (mA-mB-mC) in the cabinet, and connect the input neutral line to neutral terminal 'N' in the cabinet. Ensure correct phase rotation.

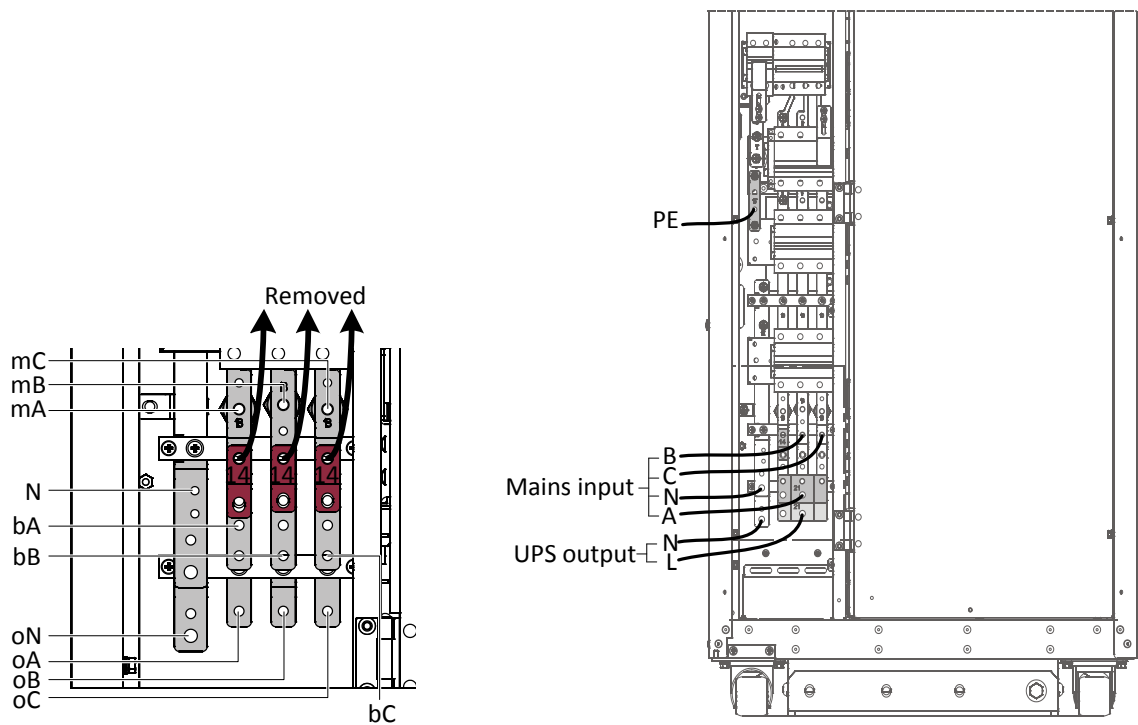

Figure 8-35 3-in 1-out, common source configuration cable connection

2. 3-in 1-out, split bypass configuration

(1) Remove the three shorting copper bars (number 14) from the rectifier input terminals mA, mB and mC, see left diagram in Figure 8-36. Use 3-in 1-out copper bars (number 21) to connect the bypass input terminals (bA-bB-bC), and then connect the output terminals (oA-oB-oC), see right diagram in Figure 8-36.

(2) Connect the rectifier input cables to rectifier input terminals (mA-mB-mC) in the cabinet, and connect the bypass input cables to the bypass shorting copper bars. Then connect the input neutral line to neutral terminal 'N' in the cabinet. Ensure correct phase rotation.

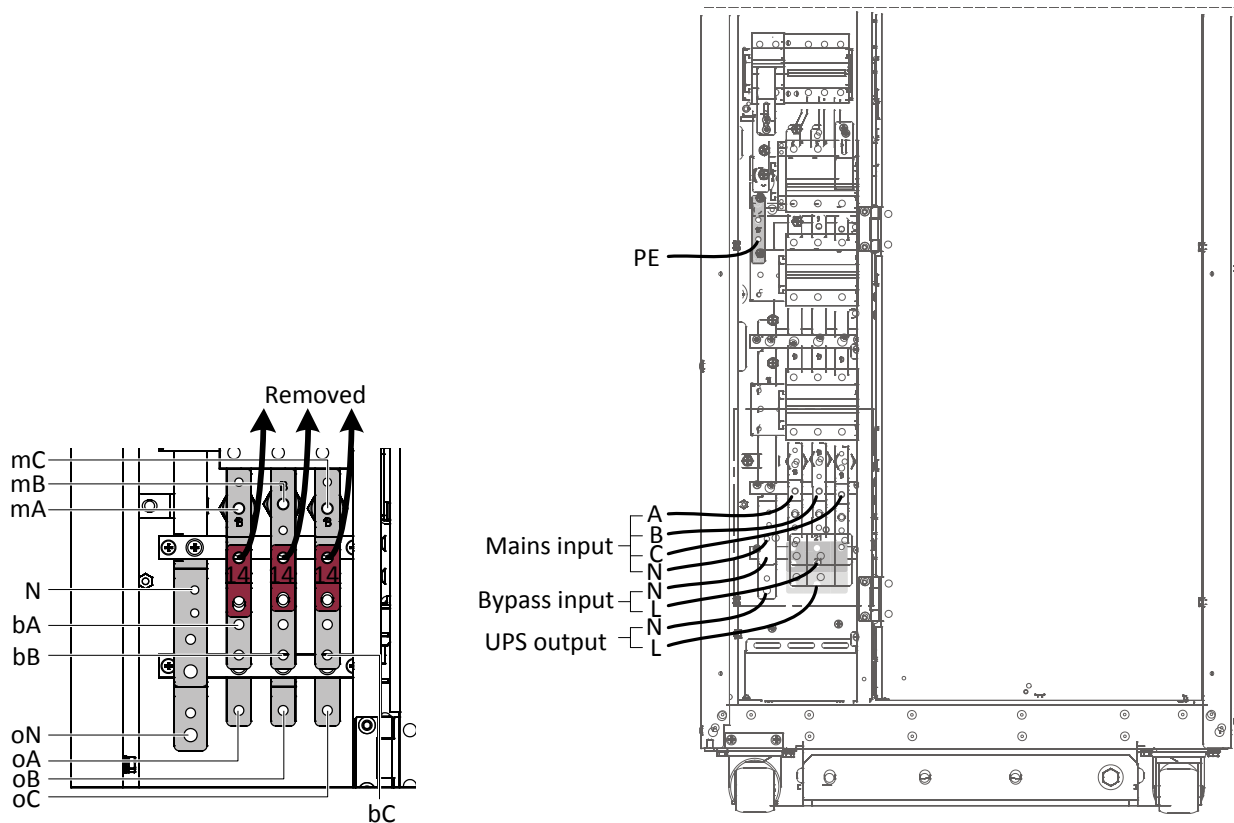

Figure 8-36 3-in 1-out, split bypass configuration cable connection

Now, the connection of input and output cables is finished.

Startup procedures

Use the following procedures to turn on the UPS from a fully powered down condition.

1. Open the front door of the UPS, ensure that the internal maintenance bypass switch Q3 is disconnected and switch Q6 is closed, while the input cables and copper bars are reliably connected. Ensure that the input cables and copper bars are reliably connected according to the 3-in 1-out power distribution mode.



Warning

All operations relating to disconnect or close the maintenance bypass switch shall be finished within three seconds, to avoid misreporting as faults.

2. Before powering on the system, use a multimeter to measure voltage of the rectifier input terminals (mA-mB-mC), and ensure that there is no short circuit, otherwise check whether the connection is correct.
3. Close the rectifier input switch Q1.

At the moment, the system is powered on, and the startup screen pops up. Refer to 4.21 Start Screen. Then press the EPO button within 10s, see Figure 8-37.



Figure 8-37 EPO button

4. Only authorized personnel shall change the 3-in 3-out mode into 3-in 1-out mode through Vertiv setting software. After setting, the LCD will display the screen shown in Figure 8-38.

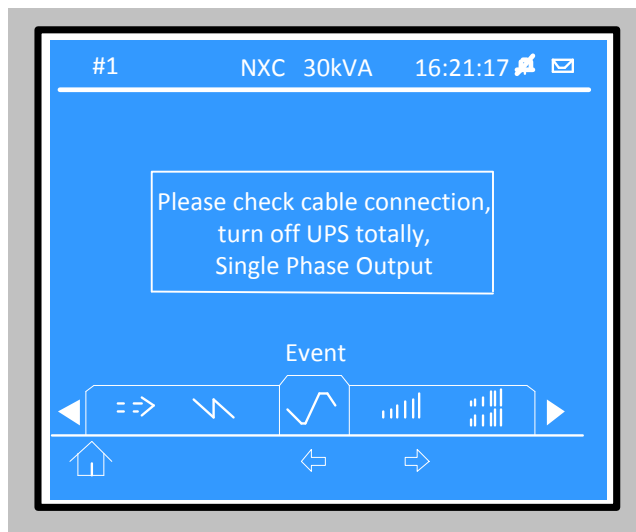

Figure 8-38 Prompt window

5. Disconnect the rectifier input switch Q1, and the UPS is shut down completely.

6. Close the bypass input switch Q2, rectifier input switch Q1 of the UPS in turn.

At the moment, the system is powered on, and the startup screen pops up. Refer to 4.2.1 *Start Screen*.

About 25 seconds later, confirm that the LCD shows the rectifier power supply and the bypass power supply are normal; if not, check whether the switches Q1 and Q2 are closed. Also check that the system display the LCD screen shown in Figure 8-39, otherwise verify that the setting is correct or not by Vertiv authorized personnel.

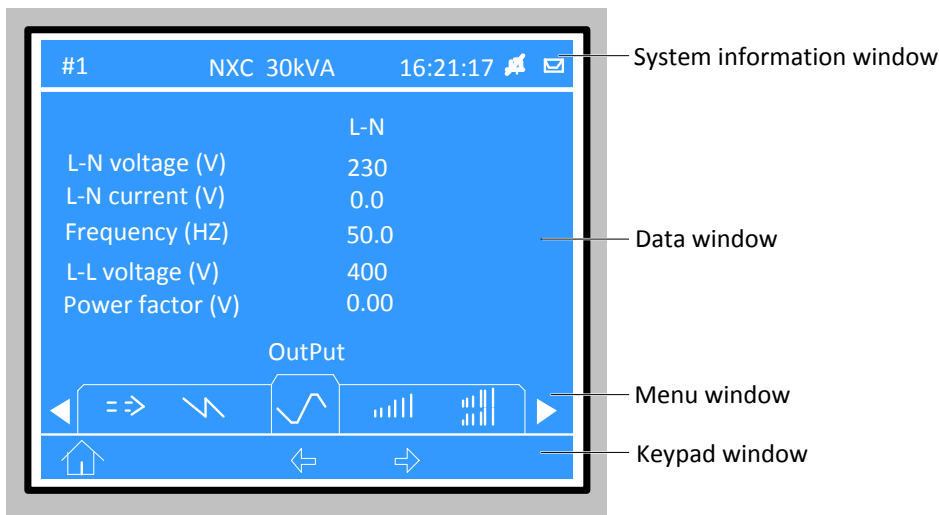

Figure 8-39 3-in 1-out mode

Then the rectifier starts up and the alarm indicator (red) is on. At the same time, the bypass static switch is closed. About 30 seconds later, the alarm indicator (red) is flashing, and then the rectifier startup is finished.

7. Close the output switch Q5 and all external output isolating switches (if any). Press the ON key for two seconds.

The inverter starts up, and the inverter indicator (green) is flashing. After the inverter runs normally, the UPS transfers from the bypass to inverter, then the inverter indicator (green) is on.

After the cable connection, find the label shown in Figure 8-40 (30kVA as an example) inside the front door of the UPS and put a tick after 'MODULE OUTPUT' and 'BYPASS INPUT' according to the actual situation for ease of maintenance.

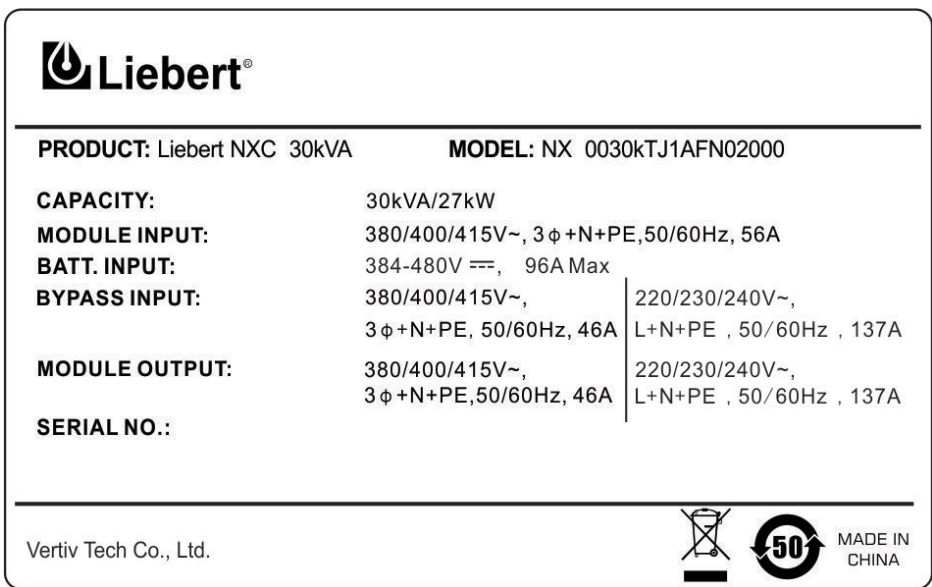

Figure 8-40 Label

Chapter 9 Communication

The UPS supports SNMP communication, Modbus protocol communication, dry contact communication and Velocity protocol communication. This chapter provides information relevant to these types of communication.

Refer to corresponding settings in Table 4-7 for communication protocol transfer. Selecting 'Velocity' means the system supports the Velocity protocol communication; selecting 'YDN23' means the system supports SNMP communication, Modbus protocol communication, dry contact communication.

9.1 SNMP Protocol Communication

If you need to monitor the UPS through network, you may select the IS-WEBL card provided by Vertiv Tech Co., Ltd. This card supports SNMP protocol.

The IS-WEBL card is a network management card. It can make the UPS made by Vertiv Tech Co., Ltd real network equipment. It can also be connected to the IRM series sensor to provide environment monitoring function. When the intelligent equipment generates an alarm, the IS-WEBL card can notify the user by recording the log, sending trap information, and sending a mail.

The IS-WEBL card provides three approaches for you to monitor your intelligent equipment and equipment room environment:

- Web browser. You can use Web browser to monitor your intelligent equipment and equipment room environment through the Web server function provided by the IS-WEBL card
- Network management system (NMS). You can use NMS to monitor your intelligent equipment and equipment room environment through the SNMP function provided by the IS-WEBL card
- SiteMonitor, the network management software for equipment room power and environment. You can use SiteMonitor to monitor your intelligent equipment and equipment room environment through the TCP/IP interface provided by the IS-WEBL card

The IS-WEBL card can also work with the Network Shutdown computer safe shutdown program developed by Vertiv Tech Co., Ltd. to provide automatic safe shutdown function for your computer installed with Network Shutdown, so as to prevent data loss.

The IS-WEBL card should be installed in the Intellislot port (see Figure 3-7) in the UPS.

For the installation and setting information of the IS-WEBL card, refer to the *Liebert IntelliSlot Web Card Quick Start Guide* in accessory.

9.2 Modbus Protocol Communication

The UPS can achieve Modbus communication through the optional IS-485L card. For the installation and use of the IS-485L card, refer to the *Liebert IntelliSlot Modbus 485, Modbus IP And BACnet IP Reference Guide* in accessory.

9.3 Dry Contact Communication

The UPS provides the following two dry contact communication approaches:

- IS-Relay card (option)
- Dry contact port

9.3.1 Communication Through IS-Relay Card

The UPS provides an optional IS-Relay card for the user to use dry contact signals to monitor the UPS. The IS-Relay card should be installed in an Intellislot port (see Figure 3-7) of the communication box in the cabinet. For the installation and use of the IS-Relay card, refer to the *Liebert IntelliSlot Relay Card User Manual* in accessory.

9.3.2 Communication Through Dry Contact Port

For on-site specific needs, the UPS may need auxiliary connection to achieve functions like acquiring external equipment status information, providing alarm signals to external devices, and remote EPO. These functions are realized through the following interfaces on the external interface board (EIB):



- Input dry contact port
- Output dry contact port
- EPO input port

For the functions and detailed information of these ports, refer to 3.2 *Wiring Of Signal Cable*.

Chapter 10 Service And Maintenance

The UPS system (including battery) needs regular service and maintenance in long-term operation. This chapter elaborates on the advice on the service life, regular inspection, maintenance and replacement of the UPS key components. Effective maintenance of the UPS system can reduce the risk in UPS failure and prolong the UPS service life.

10.1 Safety

  Warning
<ol style="list-style-type: none"> 1. Daily inspection of UPS systems can be executed by people who have received relevant training, and the inspection and replacement of devices should be operated by authorized professionals. 2. The components that can only be accessed by opening the protective cover with tools cannot be operated by the user. Only qualified service personnel are authorized to remove such covers. 3. Note that the neutral line has hazardous voltage when servicing the UPS.

10.2 Key Components And Service Life Of UPS

When in use, some devices of UPS system will have shorter service life than UPS itself due to abrasion in work. For the safety of UPS supply system, it is necessary to have regular inspection and replacement of these devices. This section introduces the key components of UPS and the reference years of service life. For systems under different conditions (environment, load rate, and etc.), assessment and advice by professionals on whether to replace the device are required with reference to the information provided in this section.

10.2.1 Life Parameters And The Proposed Replacement Time Of Key Components

Key components in Table 10-1 are used in the UPS system. To prevent system failures due to some of the devices' failure by wear, it is proposed to carry out regular inspection and replacement during its estimated life.

Table 10-1 Life parameters and the proposed replacement time of key components

Key components	Estimated life	Proposed replacement time	Proposed inspection period
Fan	Not less than 7 years	Five years to six years	One year
Air filter	One year to three years	One year to two years	Two months
VRLA battery (5-year life)	Five years	Three year to four years	Six months
VRLA battery (10-year life)	10 years	Six years to eight years	Six months

10.2.2 Replacement Of Air Filter

The air filters need regular inspection and replacement. The inspection and replacement intervals are related to the environmental conditions of the UPS. Under normal environmental conditions, the air filters should be cleaned or replaced once every two months and need more frequent cleaning and replacement in dusty or other harsh environments. Frequent inspection or replacement should also be made in new buildings.

The UPS provides air filters on the back of the front doors of the cabinet, and the user can replace the air filter during the UPS operation.

Each air filter is fixed by a fixing bar on both sides. Refer to Figure 10-1, the following is the air filter replacement procedures:

1. Open the front door of the UPS to reveal the air filter on the back of the front door.
2. Remove a fixing bar on one side and loosen the fixing screws of the fixing bar on the other side, with no need to remove this fixing bar.
3. Remove the air filter to be replaced, and insert a clean one.
4. Re-install the removed fixing bar in the original place and tighten the fixing screws.
5. Tighten the fixing screws of the fixing bar on the other side.

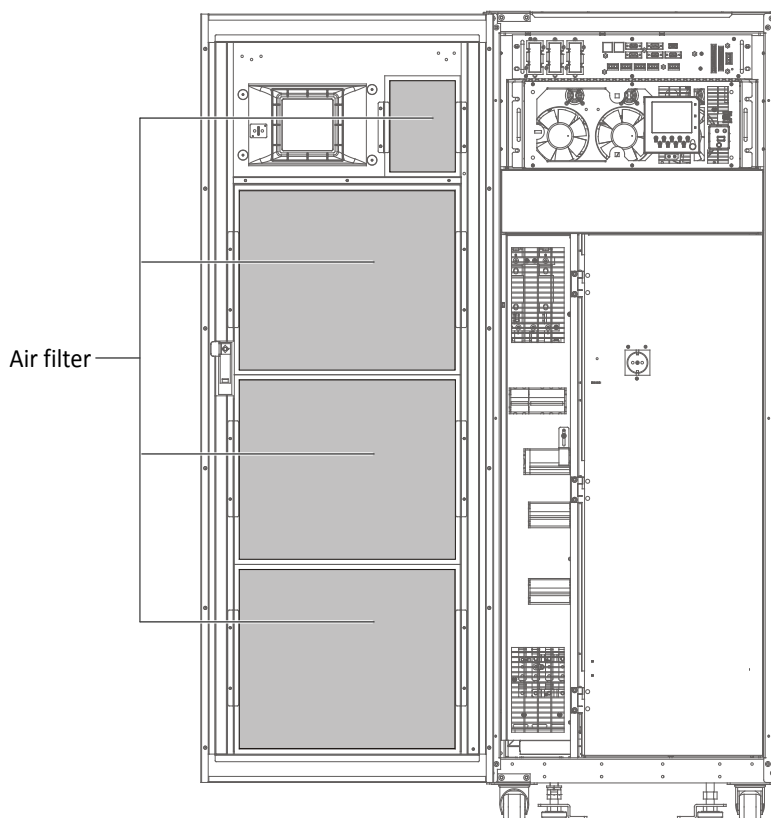

Figure 10-1 Replacing air filter

10.2.3 Replacement Of Fuse

When replacing the fuses on copper bars of the battery input terminals, use fuses of the same model as the original ones. Note that the AC fuses and DC fuses in the system are not interchangeable.

10.3 Maintenance Of UPS And Options

UPS and the options need common maintenance:

1. Keep good history record. Keeping good history record facilitates failure treatment.
2. Keep clean, so as to prevent UPS from the invasion of dust and moisture.
3. Maintain appropriate ambient temperature. The most appropriate temperature for battery is 20°C to 25°C. Too low temperature will reduce the battery capacity and too high temperature will reduce the battery life.

4. Check the wiring. Check the tightening of all connected screws, and there should be routine tightening at least once a year.
5. Check regularly if there is any abnormality in the superior or subordinate switch to ensure cutting off the import or export when the current is too large. Maintenance staff should be familiar with the typical ambient conditions where UPS is working in order to rapidly position which ambient conditions are unusual; the setting of UPS operation control panel should be known as well.

For information of the UPS battery maintenance, refer to *6.11 Battery Maintenance*.

Chapter 11 Specifications

This chapter lists the UPS specifications.

11.1 Conformance And Standards

The UPS has been designed to comply with the European and international standards listed in Table 11-1.

Table 11-1 European and international standards

Item	Normative reference
General safety requirements for UPS	EN62040-1/IEC62040-1/AS62040-1
EMC requirements for UPS	EN62040-2/IEC62040-2/AS62040-2
Method of specifying the performance and test requirements of UPS	EN62040-3/IEC62040-3/AS62040-3 (VFI SS 111)



Note

The product standards in this table incorporate relevant compliance clauses with generic IEC and EN standards for safety (IEC/EN/AS60950), electromagnetic emission and immunity (IEC/EN/AS61000 series) and construction (IEC/EN/AS60146 series and 60529).

11.2 Environmental Characteristics

Table 11-2 Environmental characteristics

Item	Unit	Rated power (kVA)	
		30kVA	40kVA
Noise within 1m (in the front)	dB (A)	56	58
Altitude	m	≤ 1000 (derate power by 1% per 100m when above 1000m)	
Relative humidity	%RH	0 ~ 95%, non condensing	
Operating temperature	°C	0 ~ 40°C (Note: Battery life is halved for every 10°C increase above 20°C)	
Storage and transport ation temperature for UPS	°C	-40°C ~ +70°C	
Over-voltage level		Overvoltage level 2	
Pollution level		Pollution level 2	

11.3 Mechanical Characteristics

Table 11-3 Mechanical characteristics

Item	Unit	Rated power (kVA)	
		30kVA	40kVA
Dimensions (W × D × H)	mm	600 × 850 × 1600	
Net weight	kg	210	
Gross weight	kg	245	
Color		Black ZP7021	
Protection degree, IEC (60529)		IP20 (front door open or closed)	

11.4 Electrical Characteristics (Input Rectifier)

Table 11-4 Rectifier AC input (mains)

Item	Unit	Rated power (kVA)	
		30kVA	40kVA
Rated AC input voltage ¹	Vac	380/400/415, 3-phase 4-wire (+PE) TN/TT power distribution system	
Input voltage range ²	Vac	305 ~ 477	
Frequency ²	Hz	50/60 (range: 40 ~ 70)	
Power factor	kW/kVA, full load (half load)	0.99 (0.98)	
Input current	A, rated ³	50	64
Total current harmonic distortion	%	Linear full load < 4% (battery float charge) (3-in 3-out) Non-linear full load < 6% (battery boost charge) (3-in 3-out) Linear full load < 6% (battery float charge) (3-in 1-out) Non-linear full load < 10% (battery boost charge) (3-in 1-out)	Linear full load < 4% (battery float charge) (3-in 3-out) Non-linear full load < 6% (battery boost charge) (3-in 3-out) Linear full load < 6% (battery float charge) (3-in 1-out) Non-linear full load < 10% (battery boost charge) (3-in 1-out)
Duration of progressive power walk-in	s	5s to reach full rated current (selectable 10s through 25s in 5-second intervals)	



Note

1. Rectifiers operate at any of the rated supply voltages and frequencies without further adjustment.
2. At 305V input mains the UPS maintains the specified output voltage at rated load without discharging a battery.
3. IEC62040-3/EN50091-3: at rated load and input voltage 400V, battery fully charged.

11.5 Electrical Characteristics (Intermediate DC Circuit)

Table 11-5 Battery

Item	Unit	Rated power (kVA)	
		30kVA	40kVA
Quantity of lead-acid blocks	Block	30*, 32, 34, 36, 38, 40 (12Vdc)	
Float voltage	V/cell (VRLA)	2.27 (selectable from 2.2V/cell to 2.3V/cell) Constant current and constant voltage charge mode	
Temperature compensation	mV/°C/cell	-3.0 (selectable from 0 to -5.0 around 25°C or 30°C, or inhibit)	
Ripple voltage (float charge)	%	≤ 1.414%	
Boost voltage	V/cell (VRLA)	2.35 (selectable from 2.3 to 2.4) Constant current and constant voltage charge mode	
Boost control		Float-boost current trigger 0.050C ₁₀ (selectable from 0.001 to 0.070) Boost-float current trigger 0.010C ₁₀ (selectable from 0.001 to 0.025) 24h safety time timeout (selectable from 8h to 30h) Boost mode inhibit also selectable	
EOD voltage	V/cell (VRLA)	1.60 ~ 1.85	

Battery Boost charge	V/cell	2.35 Constant current and constant voltage charge mode Programmable automatic trigger or inhibit of boost mode
----------------------	--------	--

**Note**

*: When the model is 40kVA and the battery cell is 30, the Vertiv authorized personnel shall set the EOD voltage value to 1.75 V/cell.

11.6 Electrical Characteristics (Inverter Output)

Table 11-6 Inverter output (to critical load)

Item	Unit	Rated power (kVA)	
		30kVA	40kVA
Rated AC voltage ¹	Vac	380/400/415 (3-phase 4-wire, with neutral reference to the bypass neutral) (3-in 3-out) 220/230/240 (3-phase 4-wire, with neutral reference to the bypass neutral) (3-in 1-out)	
Frequency ²	Hz	50/60	
Overload	%	For linear load requirement: < 105%, continues; 105 ~ 125% of rated load, 5min; 125 ~ 150% of rated load, 1min; > 150%, 200ms	
Non-linear load capability ³	%	100%	
Steady state voltage stability	%	±1% for balanced three phase load; ±2% for unbalanced load	±1% for balanced three phase load; ±2% for unbalanced load
Transient voltage response ⁴	%	±5% for 100% rated linear load step	
Total harmonic voltage	%	2% (0 ~ 100% linear load); 5% (0 ~ 100% non-linear load)	2% (0 ~ 100% linear load); 5% (0 ~ 100% non-linear load)
Synchronisation window	Hz	Rated frequency ±0.5, ±1, ±2, ±3 (optional)	
Slew rate (max. change rate of synchronisation frequency)	Hz/s	Setting range: 0.1 ~ 0.6 (UPS module), 0.6 (parallel system)	



Note

1. Factory set to 380V. 400V or 415V selectable by service engineer.
2. Factory set to 50Hz. 60Hz selectable by service engineer. Note that the system frequency can be changed only when the UPS is on bypass. It is strictly prohibited to change the system frequency when the UPS is on inverter.
3. EN 50091-3 (1.4.58) crest factor 3:1, non-linear load.
4. IEC 62040-3/EN 50091-3 also for 0 ~ 100% ~ 0 load transient. Transient recovery time: return to within 5% of steady state output voltage within half a cycle.

11.7 Electrical Characteristics (Bypass Input)

Table 11-7 Bypass input

Item	Unit	Rated power (kVA)		
		30kVA	40kVA	
Rated AC voltage ¹	Vac	380/400/415, 3-phase 4-wire, sharing neutral with the rectifier input and providing neutral reference to the output, (3-in 3-out) 220/230/240, single-phase 2-wire, sharing neutral with the rectifier input and providing neutral reference to the output, (3-in 1-out)		
Rated current	380V	A	46 (3-in 3-out), 137 (3-in 1-out)	61 (3-in 3-out), 182 (3-in 1-out)
	400V	A	44 (3-in 3-out), 132 (3-in 1-out)	58 (3-in 3-out), 174 (3-in 1-out)
	415V	A	42 (3-in 3-out), 126 (3-in 1-out)	56 (3-in 3-out), 168 (3-in 1-out)

Item	Unit	Rated power (kVA)	
		30kVA	40kVA
Overload	%	Based on nominal voltage and rated load current under apparent power: < 105%, continues; 105 ~ 125% of rated load, 5min; 125 ~ 150% of rated load, 1min; 150 ~ 400% of rated load, 1s; > 400%, 200ms	
Frequency ²	Hz	50/60	
Bypass voltage tolerance	%Vac	Upper limit: +10%, +15% or +20%, default: +15%; Lower limit: -10%, -20%, -30% or -40%, default: -20%	
Bypass frequency tolerance	%	±10% or ±20%, default: ±20%	
Synchronisation window	Hz	Rated frequency ±0.5, ±1, ±2, ±3 (optional)	



Note

1. Factory set to 380V. 400V or 415V selectable by service engineer.
2. Factory set to 50Hz. 60Hz selectable by service engineer.

11.8 Efficiency And Loss

Table 11-8 Efficiency and loss

Item	Unit	Rated power (kVA)		
		30kVA	40kVA	
Efficiency				
Normal mode	100% load	%	94.7%	94.4%
	75% load	%	94.8%	94.7%
	67% load	%	94.8%	94.7%
	50% load	%	94.6%	94.8%
	33% load	%	93.5%	94.3%
	25% load	%	91.7%	93.6%
ECO mode (100% load)	%	98.4%	98.4%	
Loss				
Normal mode (no load)	kW	0.35	0.35	
Normal mode (full load)	kW	1.530	2.150	



Note

400Vac input and output, battery fully charged, full-rated linear load.

Appendix 1 Disposal Of Old Appliances

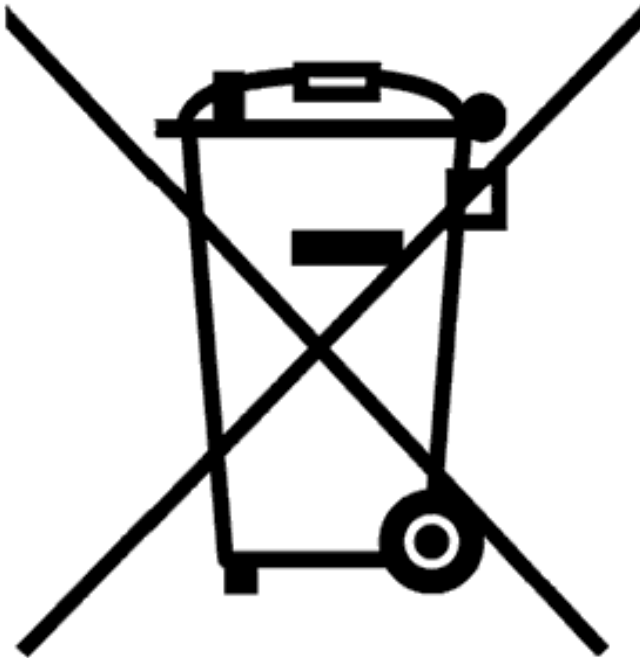

NOTICE TO EUROPEAN UNION CUSTOMERS: DISPOSAL OF OLD APPLIANCES

This product has been supplied from an environmentally responsible manufacturer that complies with the Waste Electrical and Electronic Equipment (WEEE) Directive 2002/96/CE.

The 'crossed-out wheelie bin' symbol on the right is placed on this product to encourage you to recycle wherever possible. Please be environmentally responsible and recycle this product at your local recycling facility at its end of life. Do not dispose of this product as unsorted municipal waste. Follow local municipal waste ordinances for proper disposal provisions to reduce the environmental impact of waste electrical and electronic equipment (WEEE).

For information regarding the scrapping of this equipment please contact your closest Vertiv Representative.

Appendix 2 Glossary

AC	Alternating current
BCB	Battery circuit breaker
CSA	Cross sectional area
DC	Direct current
EIB	External interface board
EMC	Electromagnetic compatibility
EMI	Electromagnetic interference
EOD	End-of-discharge
EPO	Emergency power off
I/O	Input/output
IGBT	Integrated gate bipolar transistor
LBS	Load bus synchronizer
LCD	Liquid crystal display
LED	Light-emitting diode
PC	Personal computer
PE	Protective earth
RCCB	Residual current circuit breaker
RCD	Residual current detector
SCR	Silicon-controlled rectifier
SNMP	Simple network monitoring protocol
STS	Static transfer switch
SVPWM	Space vector pulse width modulation
UPS	Uninterruptible power system
VRLA	Valve-regulated lead-acid

Appendix 3 Hazardous Substances And Content

Parts	Hazardous substances					
	Plumbum	Hydrargyru	Cadmium	Chrome ⁶⁺	PBB	PBDE
	(Pb)	(Hg)	(Cd)	(Cr (VI))	(PBB)	(PBDE)
Hex copper stud	×	○	○	○	○	○
PCBA	×	○	○	○	○	○
AC capacitor	×	○	○	○	○	○
DC capacitor	×	○	○	○	○	○
Fan	×	○	○	○	○	○
Cables	×	○	○	○	○	○
LCD	×	×	○	○	○	○
Sensors	×	○	○	○	○	○
Large-medium power magnetic components	×	○	○	○	○	○
Circuit breaker/rotating switch	×	○	○	○	○	○
Semiconductors	×	○	○	○	○	○
Battery (when applicable)	×	○	○	○	○	○
Insulation monitoring device (when applicable)	×	○	○	○	○	×
This table is made following the regulation of SJ/T 11364.						
○: Means the content of the hazardous substances in all the average quality materials of the parts is within the limits specified in GB/T 26572						
×: Means the content of the hazardous substances in at least one of the average quality materials of the parts is outside the limits specified in GB/T 26572						
About battery: Generally follow the environmental protection use period of the battery, otherwise five years.						
Applicable scope: NXC 30kVA And 40kVA UPS						



VertivCo.com

© 2019 Vertiv Group Corp. All rights reserved. Vertiv™ and the Vertiv logo are trademarks or registered marks of Vertiv Group Corp. All other names and logos referred to are trade names, trademarks or registered trademarks of their respective owners. While every precaution has been taken to ensure accuracy and completeness herein, Vertiv Group Corp. assumes no responsibility, and disclaims all liability, for damages resulting from use of this information or for any errors or omissions. Specifications are subject to change without notice.