



# Liebert<sup>®</sup> EXM

## User Manual

20 kVA to 200 kVA, 208/120 V, 50/60 Hz

The information contained in this document is subject to change without notice and may not be suitable for all applications. While every precaution has been taken to ensure the accuracy and completeness of this document, Vertiv assumes no responsibility and disclaims all liability for damages result from use of this information or for any errors or omissions.

Refer to local regulations and building codes relating to the application, installation, and operation of this product. The consulting engineer, installer, and/or end user is responsible for compliance with all applicable laws and regulations relation to the application, installation, and operation of this product.

The products covered by this instruction manual are manufactured and/or sold by Vertiv. This document is the property of Vertiv and contains confidential and proprietary information owned by Vertiv. Any copying, use, or disclosure of it without the written permission of Vertiv is strictly prohibited.

Names of companies and products are trademarks or registered trademarks of the respective companies. Any questions regarding usage of trademark names should be directed to the original manufacturer.

### **Technical Support Site**

If you encounter any installation or operational issues with your product, check the pertinent section of this manual to see if the issue can be resolved by following outlined procedures.

# TABLE OF CONTENTS

<b>1 Important Safety Instructions</b> .....	<b>1</b>
<b>2 Introduction</b> .....	<b>7</b>
<b>3 Installation</b> .....	<b>9</b>
3.1 Initial Inspections .....	9
3.1.1 Storing the UPS and Batteries for Delayed Installation .....	9
3.2 Preliminary Checks .....	10
3.2.1 Identification .....	10
3.3 UPS Location .....	10
3.3.1 Positioning the UPS .....	10
3.3.2 Environmental Considerations .....	10
3.4 Considerations in Moving the EXM .....	10
3.5 Mechanical Considerations .....	11
3.5.1 Dimensions .....	12
3.5.2 Clearances .....	13
3.5.3 Floor Installation .....	13
3.5.4 Cable Entry .....	13
3.6 Auxiliary Cabinets .....	15
3.7 Vertiv™ Liebert® Power Module Assembly .....	17
3.8 Control Module .....	18
3.9 Static Bypass Assembly .....	18
<b>4 Electrical Connections UPS</b> .....	<b>19</b>
4.1 Power Cabling .....	19
4.1.1 Lug Size and Cable Rating .....	19
4.2 External Protective Devices .....	20
4.2.1 Rectifier and Bypass Input Supply of the UPS .....	20
4.2.2 UPS Output .....	21
4.2.3 UPS Input Configuration .....	21
4.2.4 Cabling Guidelines .....	23
4.2.5 Cable Connections .....	23
4.2.6 Accessory Fuses and Back Feed Breaker Wiring .....	24
4.2.7 Safety Ground .....	27
4.2.8 Protective Devices .....	28
4.2.9 Cabling Procedure .....	28
4.3 Control Cables Details .....	29
4.3.1 Static Bypass Assembly Features .....	29
4.4 Dry Contacts .....	30
4.4.1 Input Dry Contacts .....	30

- 4.4.2 Output Dry Contacts ..... 32
- 4.4.3 Vertiv™ Liebert® EXM MBC Interface ..... 33
- 4.4.4 Battery Cabinet Interface Connectors ..... 33
- 4.4.5 EPO Input-Optional ..... 35
- 4.5 Parallel Cable Connections ..... 37
- 5 Installation Drawings ..... 39**
- 6 Option Installation ..... 43**
- 6.1 Vertiv™ Liebert® IntelliSlot™ Communication ..... 43
- 6.2 Liebert® IntelliSlot™ Web Card - SNMP/HTTP Network Interface Card ..... 43
  - 6.2.1 Liebert® IntelliSlot™ Unity Cards - IS-UNITY-LIFE, IS-UNITY-S, IS-UNITY-DP ..... 43
- 6.3 Liebert® IntelliSlot™ Web Card (Optional) ..... 44
- 6.4 Liebert® IntelliSlot™ Relay Card ..... 44
  - 6.4.1 Liebert® IntelliSlot™ Relay Card Pin Configuration ..... 45
  - 6.4.2 Vertiv™ Liebert® IntelliSlot™ Relay Card Jumper Setup ..... 45
- 7 Operation ..... 47**
- 7.1 Touchscreen Control Panel ..... 47
- 7.2 Access Level Log In ..... 48
- 7.3 Default PIN Numbers ..... 48
- 7.4 Vertiv™ Liebert® EXM Operating Modes ..... 48
- 7.5 UPS Startup ..... 51
  - 7.5.1 Startup Procedure ..... 51
  - 7.5.2 Startup in Eco Mode ..... 52
  - 7.5.3 Switching Between UPS Operation Modes ..... 52
- 7.6 Switching the UPS from Normal Operation to Maintenance Bypass ..... 52
- 7.7 Switching the UPS from Maintenance Bypass to Normal Operation ..... 55
- 7.8 De-Energize Liebert® EXM with Maintenance Bypass Cabinet ..... 56
- 7.9 De-Energize Vertiv™ Liebert® EXM Without Maintenance Bypass Cabinet ..... 56
- 7.10 Parallel Operations—Determine Control Panel Firmware ..... 58
- 7.11 Parallel Operations - Software Version 1.1 ..... 58
  - 7.11.1 De-Energize a Vertiv™ Liebert® EXM Parallel System Software Version 1.1 ..... 58
  - 7.11.2 Re-Energize a EXM Parallel System Software Version 1.1 ..... 58
- 7.12 Emergency Shutdown with EPO ..... 59
- 7.13 Auto Restart ..... 59
- 7.14 Reset After Shutdown for Emergency Stop (EPO Action) or Other Conditions ..... 59
- 7.15 Battery Protection ..... 60
  - 7.15.1 Battery Undervoltage Warning ..... 60
  - 7.15.2 Battery End of Discharge (EOD) Protection ..... 60
- 7.16 Operation ..... 60
- 7.17 Static Bypass Switch ..... 61
- 8 Specification and Technical Data ..... 63**

8.1 Conformity and Standards .....	63
8.1.1 ENERGY STAR Certification .....	63
8.2 UPS Environmental Requirements .....	63
8.3 UPS Electrical Characteristics .....	64
<b>9 Maintenance .....</b>	<b>71</b>
9.1 Safety Precautions .....	71
9.2 Limited Life Components .....	72
9.3 Routine Maintenance .....	73
9.3.1 Record Log .....	73
9.3.2 Air Filters .....	73
9.3.3 Torque Requirements .....	75
9.4 Detecting Trouble .....	75
9.5 Reporting a Problem .....	75
9.6 Corrective Actions .....	76
9.7 Recommended Test Equipment .....	76
<b>Appendices .....</b>	<b>77</b>
Appendix A: Hazardous Substances or Elements Announcement .....	77
Appendix B: UPS Status Messages .....	79

This page intentionally left blank

# 1 Important Safety Instructions

## Save These Instructions

This manual contains important instructions that should be followed during installation of the Vertiv™ Liebert® EXM UPS. Read this manual thoroughly, paying special attention to the sections that apply to your installation, before working with the UPS. Retain this manual for use by installing personnel.

A properly trained and qualified electrical contractor should oversee the installation of the equipment.

The EXM cannot be put into operation until it is commissioned by the manufacturer or authorized engineer. Otherwise, human safety may be endangered and damage to the UPS will not be covered by the warranty.

For life support application is mandatory formal approval by Vertiv.



**WARNING! Risk of moving heavy equipment and electric shock. It can cause damage to the equipment, injury and death. Exercise extreme care when handling the UPS cabinets to avoid damage to the equipment or injury to personnel. The weight of the EXM UPS ranges from 684 lb (320 kg) to 1516 lb (688 kg). Locate the center of gravity symbols before handling the UPS . Test lift and balance the cabinet before transporting it. Never tilt the equipment more than 15 degrees from vertical. In case of fire involving electrical equipment, use only carbon dioxide fire extinguishers or those approved for use in fighting electrical fires. Extreme caution is required when performing maintenance. Be constantly aware that the UPS system contains high DC as well as AC voltages. Check for voltage with both AC and DC voltmeters prior to making contact.**

Risque lors du déplacement de l'équipement lourd et de décharge électrique pouvant entraîner des dommages matériels, des blessures et même la mort. Faites preuve d'une extrême prudence lors de la manutention des armoires ASC afin d'éviter de les endommager ou de blesser le personnel. L'armoire EXM pèse de 684 lb (320 kg) à 1516 lb (688 kg). Repérez les symboles de centre de gravité  avant de déplacer l'armoire ASC. Faites des essais de levage et d'équilibre avant de transporter l'armoire. N'inclinez jamais l'équipement à plus de 15 degrés à la verticale. En cas d'incendie associé à du matériel électrique, n'utilisez que des extincteurs à dioxyde de carbone ou homologués pour la lutte contre les incendies d'origine électrique. Les opérations d'entretien requièrent une extrême prudence. Soyez toujours conscient du fait que le système ASC contient des tensions c.c. et c.a. élevées. Vérifiez les tensions avec des voltmètres c.a. et c.c. avant d'établir tout contact.



**WARNING! Risk of electric shock. It can cause damage to the equipment, injury and death. As with the other types of high power equipment, dangerous voltages are present within the UPS and the battery enclosure even after the input power has been disconnected. The risk of contact with these voltages is minimized as the live component parts are housed behind a metal panel. Further internal safety screens make the equipment protected to IP20 standards. Never remove panels or covers or open doors that will expose internal components to contact. Read and follow all warnings, cautions and safety and operating instructions to avoid serious injury or death from electric shock. No risk exists to any personnel when operating the equipment in the normal manner, following the recommended operating procedures. All equipment maintenance and servicing procedures involve internal access and should be carried out only by trained personnel.**

Risque de décharge électrique pouvant entraîner des dommages matériels, des blessures et même la mort. À l'instar des autres types d'équipement haute puissance, des tensions dangereuses sont présentes à l'intérieur de l'armoire ASC et du châssis de batteries même après le débranchement de l'alimentation d'entrée. Le risque de contact avec ces tensions est diminué, car les parties de composants sous tension sont abritées derrière un panneau métallique. D'autres écrans de sécurité internes protègent l'équipement en conformité avec les normes IP20. Ne retirez jamais les panneaux ou les couvercles et n'ouvrez pas les portes donnant accès aux composants internes avec lesquels vous pouvez entrer en contact. Veuillez lire et suivre l'ensemble des avertissements, des mises en garde et des instructions de sécurité et de fonctionnement afin d'éviter des blessures graves, voire la mort, pouvant être causées par une décharge électrique. Il n'y a aucun risque pour le personnel lorsque l'équipement est utilisé normalement, en suivant les procédures de fonctionnement recommandées. Toutes les procédures de réparation et d'entretien de l'équipement exigent un accès à l'intérieur de l'armoire et devraient être menées uniquement par du personnel compétent.

## Ground Leakage Currents



**WARNING! Risk of electric shock from high leakage current. It can cause damage to the property, injury and death. EARTH CONNECTION IS ESSENTIAL BEFORE CONNECTING THE INPUT SUPPLY. Earth leakage current exceeds 3.5 mA and is less than 1000 mA. The transient and steady-state earth leakage currents, which may occur when starting the equipment, should be taken into account when selecting instantaneous Residual Current Device (RCD) devices. The Residual Current Circuit Breakers must be selected sensitive to the DC unidirectional pulses (Class A) and insensitive to the transient current pulses. Note also that the earth leakage currents of the load will be carried by this RCCB or RCD. This equipment must be earthed in accordance with the local electrical code of practice.**

Risque de décharge électrique due à un courant de fuite élevé pouvant causer des blessures, des dommages matériels et même la mort. IL EST PRIMORDIAL D'ASSURER UNE CONNEXION DE TERRE AVANT DE BRANCHER L'ALIMENTATION D'ENTRÉE. La fuite à la terre est supérieure à 3,5 mA et inférieure à 1 000 mA. Vous devez tenir compte des fuites de courant transitoires et permanentes à la terre, susceptibles de se produire au démarrage de l'équipement, lors de la sélection des dispositifs DDFT instantanés. Vous devez sélectionner des disjoncteurs différentiels de fuite à la terre (DDFT) sensibles aux impulsions unidirectionnelles c.c. (classe A) et insensibles aux impulsions de courant transitoires. Notez également que les courants de fuite à la terre de la charge seront acheminés par ce dispositif DDFT. Cet équipement doit être mis à la terre conformément au code national de l'électricité.



**WARNING! Risk of electric shock. It can cause damage to the property, injury and death. Under typical operation and with all the UPS doors closed, only normal safety precautions are necessary. The area around the UPS system should be kept free of puddles of water, excess moisture and debris. Special safety precautions are required for the procedures involving handling, installation and maintenance of the UPS system. Observe all safety the precautions in this manual before handling or installing the UPS system as well as during all the maintenance procedures. This equipment contains several circuits that are energized with high voltage. Only test equipment designed for troubleshooting should be used. This is particularly true for oscilloscopes. Always check with the AC and DC voltmeters to ensure safety before making contact or using tools. Even when the power is turned Off, dangerously high electric charges may exist within the UPS. All the power and control wiring should be installed by a qualified electrician. All the power and control wiring must comply with the NEC and applicable local codes. ONLY qualified service personnel should perform maintenance on the UPS system. When performing maintenance with any part of the equipment under power, the service personnel and test equipment should be standing on rubber mats. The service personnel should wear insulating shoes for isolation from direct contact with the floor (earth ground). Never work alone, even if all the power is disconnected from the equipment. A second person should be standing by to assist and summon help in case an accident should occur.**

Risque de décharge électrique pouvant causer des blessures, des dommages matériels et même la mort. Les précautions de sécurité habituelles suffisent lorsque le système ASC est en mode de fonctionnement normal et que toutes les portes sont fermées. La zone entourant le système ASC doit être exempte de flaques d'eau, d'humidité excessive et de débris. Des précautions de sécurité spéciales sont requises pour les procédures associées à la manutention, à l'installation et à l'entretien du système ASC. Observez toutes les précautions de sécurité décrites dans le présent manuel avant de manipuler ou d'installer le système ASC, ainsi que pendant toutes les procédures d'entretien. Cet équipement comporte plusieurs circuits à haute tension. Seuls des équipements d'essai conçus pour le dépannage doivent être utilisés. Cette mise en garde couvre notamment les oscilloscopes. Utilisez toujours des voltmètres c.a. et c.c. pour vérifier les tensions avant d'établir un contact ou d'utiliser des outils. Des tensions dangereusement élevées peuvent demeurer dans le système ASC même une fois l'alimentation coupée. Tous les câbles d'alimentation et de contrôle doivent être installés par un électricien qualifié. Tous les câbles d'alimentation et de contrôle doivent être conformes au Code national de l'électricité des États-Unis (NEC) et celui du Canada, ainsi qu'aux codes locaux en vigueur. L'entretien du système ASC ne doit être confié qu'à des professionnels qualifiés. Les responsables de l'entretien et l'équipement d'essai doivent reposer sur des tapis de caoutchouc lors de toute intervention sur une pièce d'équipement sous tension. Les responsables de l'entretien doivent porter des chaussures isolantes pour prévenir tout contact direct avec le plancher. Ne travaillez jamais seul, même si toute l'alimentation d'entrée est coupée de l'équipement. Une seconde personne devrait toujours être présente pour porter assistance ou chercher de l'aide en cas d'accident.



**WARNING! Failure to follow adequate grounding procedures can result in electric shock hazard to the personnel, or risk of fire, should a ground fault occur. All operations described in this section must be performed by the properly trained and qualified electricians or the technical personnel. If any difficulties are encountered, contact Vertiv. See the back page of this manual for contact information.**

Le non-respect des procédures de mise à la terre peut entraîner des risques d'électrocution du personnel, ou des risques d'incendie en cas de défectuosité de la mise à la terre. Toutes les opérations décrites dans cette section ne doivent être effectuées que par des électriciens ou des techniciens professionnels dûment formés et qualifiés. En cas de difficultés, communiquez avec Vertiv. Pour obtenir les renseignements de contact, consultez la dernière page de ce manuel.

**NOTICE**

Risk of improper ground connection. It can cause damage to the equipment. Ground connection is essential before connecting the input supply. This equipment must be grounded in accordance with the local electrical codes. Maximum load must not exceed that shown on the UPS rating label.

**NOTICE**

Risk of improper electromagnetic shielding. It can cause radio communication interference. This unit complies with the limits for a Class A digital device, pursuant to Part 15 Subpart J of the FCC rules. These limits provide reasonable protection against harmful interference in a commercial environment. This unit generates, uses and radiates radio frequency energy and, if not installed and used in accordance with this instruction manual, may cause harmful interference to radio communications. This unit is not designed for use in a residential area. Operation of this unit in a residential area may cause harmful interference that the user is solely responsible for correcting.

## Glossary of Symbols



Risk of electrical shock



Indicates caution followed by important instructions

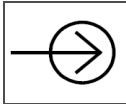

AC input

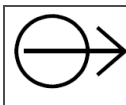

AC output



Requests the user to consult the manual

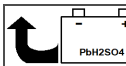

Indicates the unit contains a valve regulated lead acid battery



Recycle

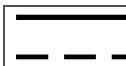

DC voltage

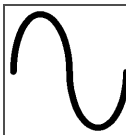

AC voltage



Equipment grounding conductor

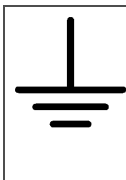

Bonded to ground

This page intentionally left blank

## 2 Introduction

The Vertiv™ Liebert® EXM UPS can be configured as either a fixed capacity or as a scalable, transformer free, online uninterruptible power system with 208/120 V input and 208/120 V output capability. The EXM can operate with either a 50 Hz or 60 Hz input and provide a matching output frequency conversion.

When configured for scalability, the capacity of the UPS can be increased in 20 kVA increments. Based on the configuration, a power module can be set to a redundant operation mode. Contact Vertiv Services about adding the capacity.

Optional Maintenance Bypass and Parallel Cabinets are also available.

The EXM provides continuous, high quality AC power to the business-critical equipment, such as telecommunications and data processing equipment. The EXM supplies power free of the disturbances and variations in voltage and frequency common to the utility power, which is subject to brownouts, blackouts, surges and sags.

The EXM utilizes the latest in high frequency, double conversion Pulse Width Modulation (PWM) technology and fully digital controls to enhance its reliability and increase the ease of use.

The 20-200 kVA/kW EXM requires external batteries to support the load when the utility power is not present. For ancillary cabinets, refer to [Auxiliary Cabinets](#) on page 15 .

This page intentionally left blank

## 3 Installation

This section describes the environmental requirements of Vertiv™ Liebert® EXM UPS and mechanical considerations that must be taken into account when planning the positioning and the cabling of the UPS equipment.

Because each site is unique, this section presents a guide to the general procedures and the practices that should be observed by the installing engineer, rather than step by step installation instructions.

### NOTICE

Risk of improper installation. It can cause damage to the equipment. Do not apply electrical power to the UPS equipment before the commissioning engineer arrives at the installation site. The UPS must be installed by a properly trained and qualified engineer in accordance with the information contained in this chapter. All the equipment not referred to in this manual is shipped with details of its own mechanical and electrical installation information.

**NOTE: Three-phase, four-wire input power is required.**

**NOTE: Input power must be supplied to the EXM from a properly grounded wye source. The EXM is not for use with impedance grounded systems, corner grounded systems or high leg Delta systems. For these applications, an isolation transformer must be installed between the input power and EXM.**

### 3.1 Initial Inspections

1. While the EXM and ancillary cabinets are still on the truck, inspect the equipment and shipping container for any signs of damage or mishandling. Do not attempt to install the system if damage is apparent. If any damage is noted, file a damage claim with the shipping agency immediately and contact Vertiv Services at 800 543-2378 to inform them of the damage claim and the condition of the equipment.
2. Compare the contents of the shipment with the bill of lading. Report any missing items to the carrier and your local Vertiv representative immediately.
3. Check the product label on the back of front door and confirm the contents match the UPS model, capacity and main parameters that were ordered.

#### 3.1.1 Storing the UPS and Batteries for Delayed Installation

If the EXM system will not be installed immediately, it must be stored indoors in a clean, dry and cool location (see **Table 8.1** on page 63 ). If the UPS includes batteries, either internally or in a battery cabinet, the batteries' requirements will dictate the storage conditions. Batteries should be unpacked, installed and charged as soon as possible after delivery.

### NOTICE

Risk of failure to properly charge batteries. It can cause permanent damage to the batteries and void the warranty. Batteries will self discharge during storage. Batteries must be recharged as recommended by the battery manufacturer. A notice of Charge Before Date is affixed to each unit that has batteries inside. The Charge Before Date is calculated based on the batteries being stored at 77 °F (25 °C). Storage at a higher temperature will increase the rate of self discharge, requiring earlier recharge. Consult the battery manufacturer on how to determine when the batteries need to be recharged.

## 3.2 Preliminary Checks

### 3.2.1 Identification

The equipment supplied has an identification tag on the back of the main door listing the type and size of the UPS.

## 3.3 UPS Location

### 3.3.1 Positioning the UPS

- Choose a location for the UPS that offers:
- Easy connection to inputs, outputs and auxiliary equipment.
- Enough space to service the UPS.
- Air circulation sufficient to expel the heat produced by the UPS.
- Protection against moisture and excessive humidity.
- Protection against dust and other particulate matter.
- Compliance with the fire prevention regulations and practices.
- Operating environment temperature of 74 °F-80 °F (23 °C-27 °C) for maximum battery life.

### 3.3.2 Environmental Considerations

Before installing the Vertiv™ Liebert® EXM UPS, verify that the UPS room satisfies the environmental conditions stipulated in **Table 8.11** on page 68, paying particular attention to the ambient temperature and the air exchange system.

The UPS unit should be installed in a cool, dry, clean air environment with adequate ventilation to keep the ambient temperature within the specified operating range of 32 °F to 104 °F (0 °C to 40 °C).

For optimal UPS system performance and service life, maintain the operating temperature within the range of 74 °F-80 °F, (23 °C-27 °C).

The EXM is cooled by the internal fans. Cooling air enters the unit through the front of the unit and is exhausted from the top. To permit proper air flow and prevent overheating, DO NOT block or cover the ventilation openings or blow air down onto the unit. The UPS requires 24 in. (610 mm) ventilation clearance above the unit.

See for details on heat dissipation.

## 3.4 Considerations in Moving the EXM

Ensure that the UPS weight is within the designated surface weight loading (lb/ft<sup>2</sup> or kg/cm<sup>2</sup>) of any handling equipment. See **Table 8.2** on page 64 for the weights of various units.

The EXM may be rolled on its casters for short distances only. For the longer distances, move the UPS with a forklift or similar equipment to ease the relocation and to reduce the vibration.



**WARNING! Risk of moving heavy unit. It can cause damage to the property, injury and death. Ensure that any equipment that will be used to move the EXM UPS has sufficient lifting capacity. The weight of the EXM UPS ranges from 684 lb (320 kg) to 1516 lb (688 kg). See **Table 3.1** on page 13 for the weights of various units. The UPS presents a tipping hazard. Do not tilt the EXM more than 15 degrees from vertical. The UPS is fitted with casters. Take care to prevent movement when unbolting the equipment from its shipping pallet. Ensure adequate personnel and lifting equipment are available when taking the EXM off its shipping pallet.**

Le poids élevé de l'appareil peut entraîner des dommages matériels, des blessures et même la mort. Veillez à ce que les équipements utilisés pour déplacer le système EXM de EXM possèdent une capacité nominale suffisante. Le poids du système EXM de Liebert varie entre 554 kg et 688 kg (1221 lb et 1516 lb) sans les batteries. Reportez vous au **Table 3.1** on page 13 pour connaître le poids de l'appareil avec les batteries. Le système ASC présente un risque de renversement. N'inclinez pas le système EXM de Liebert à plus de 15 degrés de la verticale. Comme le système ASC est équipé de roulettes, veillez à éviter les mouvements involontaires lorsque vous déboulonnez l'équipement de sa palette d'expédition. Veillez à ce qu'un personnel approprié et un dispositif de levage soient disponibles lorsque vous retirez le système EXM de Liebert de la palette d'expédition.



**WARNING! Risk of heavy unit tipping over while being moved. It can cause damage to the property, injury and death. The casters are strong enough for movement across even surfaces only. Casters may fail if they are subjected to shock loading, such as being dropped or rolled over holes on the floor or obstructions. Such failure may cause the unit to tip over, injuring personnel and damaging the equipment.**

Le centre de gravité élevé de l'appareil présente un risque de renversement lors des déplacements, peut entraîner des dommages matériels, des blessures et même la mort. Les roulettes sont suffisamment résistantes pour le déplacement sur des surfaces planes uniquement. Les roulettes peuvent être endommagées si vous les soumettez à des impacts, notamment en cas de chute ou de passage sur des obstacles ou trous dans le plancher. Une telle défaillance peut causer le renversement de l'appareil, qui risque de blesser le personnel et d'endommager l'équipement.

## Final Positioning

When the equipment has been finally positioned, ensure that the adjustable stops are set so that the UPS will remain stationary and stable. See **Figure 3.1** on the next page .

The Vertiv™ Liebert® EXM and its auxiliary cabinets must be installed on a concrete or equivalent, non-resilient floor.

## 3.5 Mechanical Considerations

The Liebert® UPS is constructed with a steel frame and removable panels. The top and the side panels are secured to the chassis by the screws. The doors may be opened for access to the power connection bars, the auxiliary terminals block and the power switches.

The UPS comes with an Operator Control Panel that provides basic operational status and alarm information. The cabinet houses the power components. Cooling is provided by the internal fans. The unit sits on four casters. Adjustable stops are provided to prevent the UPS from moving once it has been moved to its final position.

The wiring cabinet shown in **Figure 3.1** on the next page provides the additional space to support the wiring and the conduit landing for the 16 kVA to 200 kVA models of the Vertiv™ EXM. The wiring cabinet is added to the UPS when a Vertiv™ Liebert® EXM MBC is not used. The wiring cabinet provides space for the conduit and the power connections to a customer supplied maintenance bypass cabinet.

### 3.5.1 Dimensions

Figure 3.1 UPS Dimensions

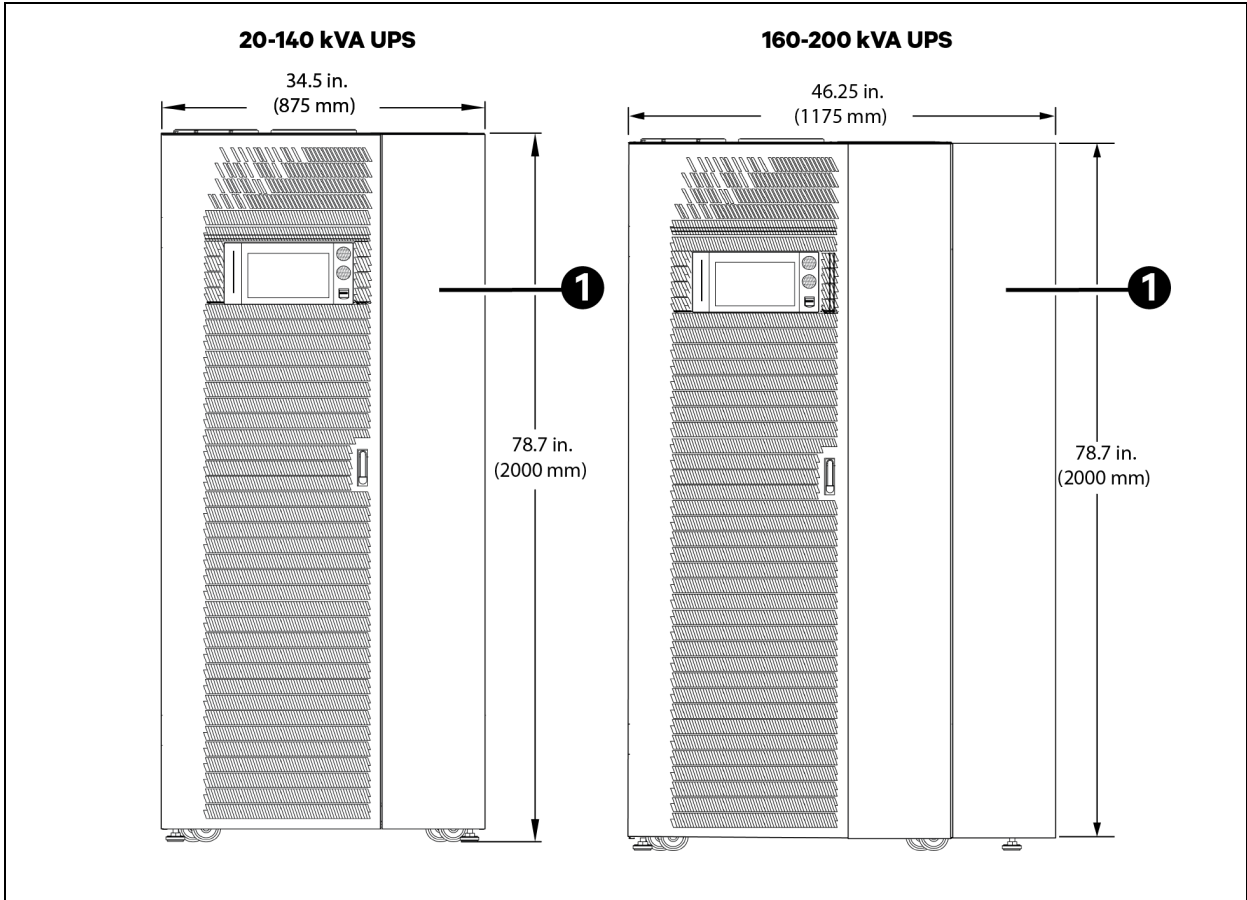

Item	Description
1	Wiring cabinet

## 3.5.2 Clearances

Figure 3.2 Clearances

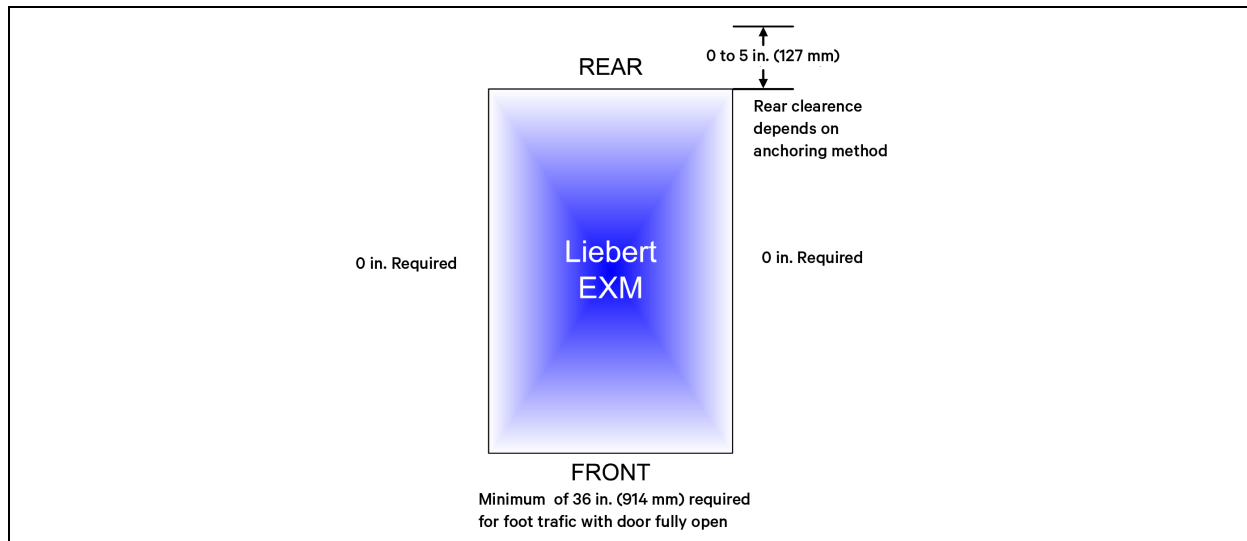

Table 3.1 UPS Weight

UPS Rating KVA	Unit Weight lb. (kg)	Shipping Weight lb. (kg)	UPS Rating KVA	UNIT Weight LB. (kg)	Shipping Weight Lb.(kg)
20	684 (320)	784 (356)	120	1221 (554)	1321 (600)
40	758 (344)	858 (389)	140	1295 (587)	1395 (633)
60	844 (383)	944 (428)	160	1368 (621)	1468 (666)
80	918 (416)	1018 (462)	180	1442 (654)	1542 (699)
100	992 (450)	1092 (495)	200	1516 (688)	1616 (733)

Provide at least minimum clearance required by the NEC on all sides of the Vertiv™ Liebert® EXM UPS, including 36 in. (914 mm) in front, to permit routine tightening power terminations within the UPS and free passage for personnel with the door fully opened. Depending on the floor anchoring system used, up to 5 in. (127 mm) may be required in the rear of the UPS.

There are no ventilation grilles on the sides or back of the UPS.

Leave a minimum of 24 in. (610 mm) between the top of the UPS frame and the ceiling to permit adequate air circulation above the unit. Vertiv recommends against using the air conditioning or other systems that blow air onto the top of the unit.

## 3.5.3 Floor Installation

If the Vertiv™ Liebert® EXM is to be placed on a raised floor, the UPS should be mounted on a pedestal that will support the equipment point loading. To design this pedestal (Refer to the bottom view in **Figure 3.1** on the previous page ).

## 3.5.4 Cable Entry

Cables can enter the Liebert® EXM UPS from the top or the bottom through the removable metal plates.

Some plates have factory-punched holes and others are designed to allow the personnel to punch holes for fitting and securing the conduit. Once the conduit holes are punched, these plates should be reattached to the UPS. The conduit size and wiring method must be in accordance with all the local, regional and national codes and regulations, including the NEC ANSI/NFPA 70.

The UPS must be accessible from the front to allow the personnel to complete the cable connections and make necessary adjustments.

**NOTE:** When installing the UPS, the customer must provide a disconnect with the overcurrent protection at the output of the UPS.

**Figure 3.3 Cable Entry Locations, 20-140 kVA Model**

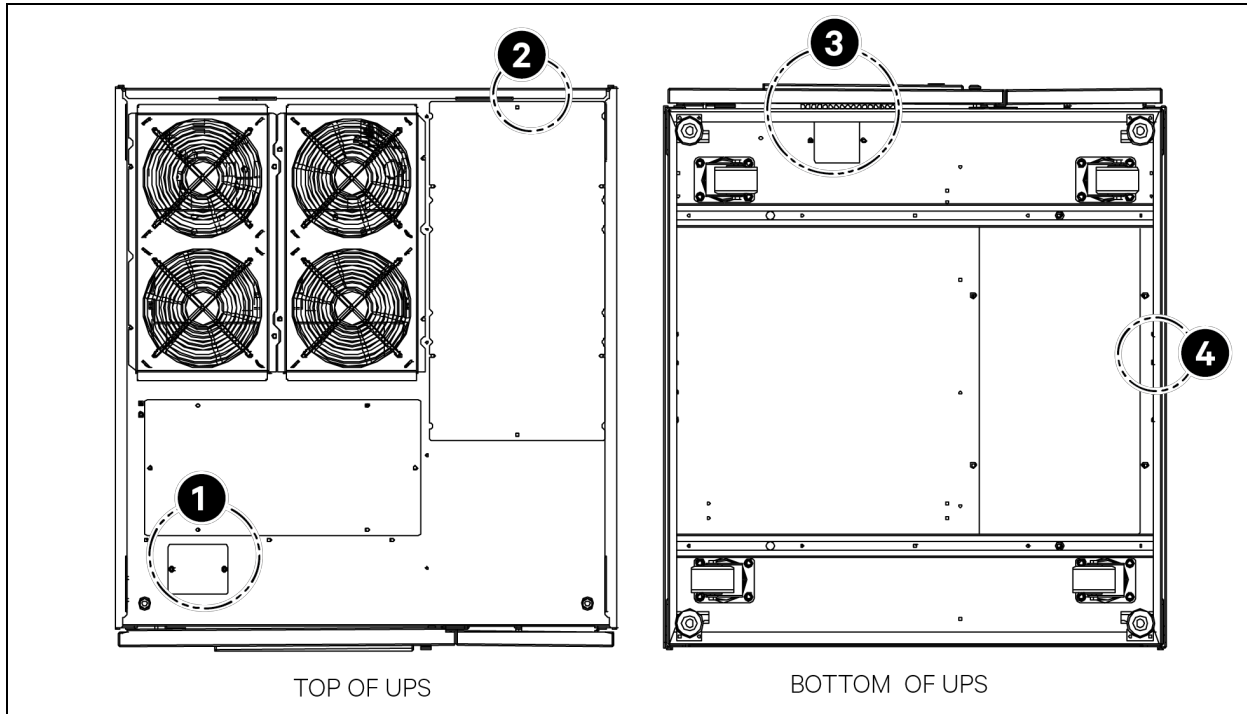

Item	Description	Item	Description
1	Top control cable entry	3	Bottom control cable entry
2	Top power cable entry	4	Bottom power cable entry

Figure 3.4 Cable Entry Locations, 160-200 kVA Model

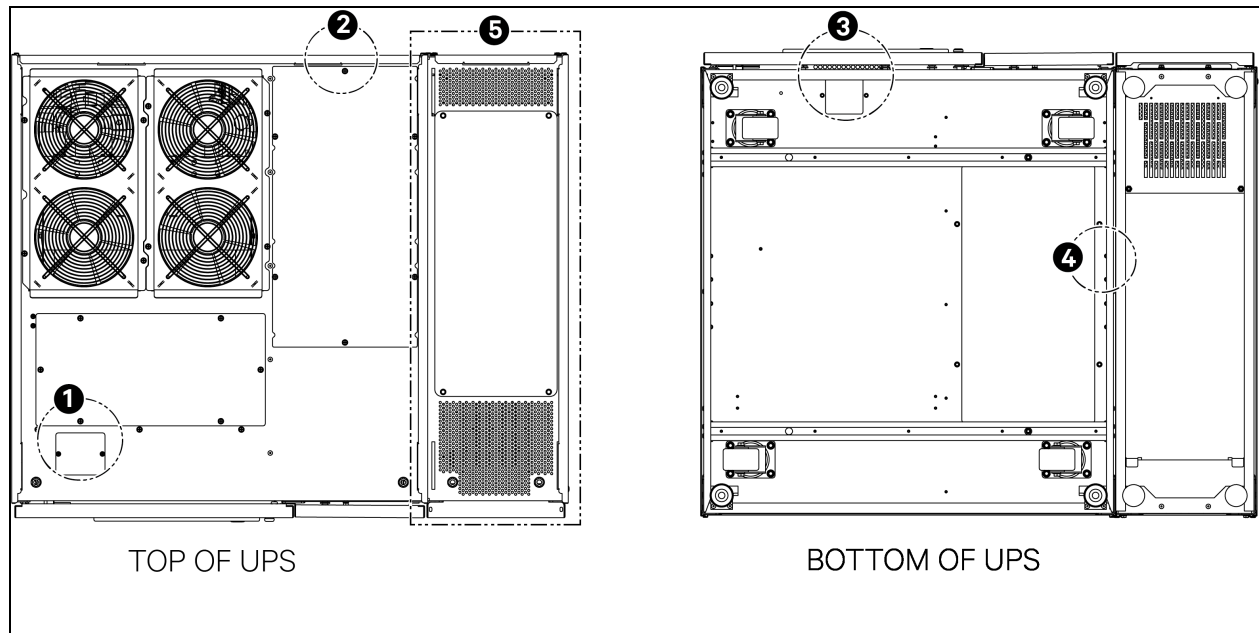

Item	Description	Item	Description
1	Top control cable entry	3	Bottom control cable entry
2	Top power cable entry	4	Bottom power cable entry

## 3.6 Auxiliary Cabinets

The 20 kVA to 200 kVA frame consists of a single cabinet housing the UPS components. It does not accommodate internal batteries. The UPS requires external battery cabinets for extended run time.

### Battery Cabinets

Optional battery cabinets are available for each Vertiv™ Liebert® EXM UPS model to provide extended run time. The battery cabinets are designed to be bolted to the left side of the UPS (see [Figure 3.5](#) on the next page ). Refer to the [Vertiv™ Liebert® EXM External Battery Cabinet User Manual \(SL-25651\)](#) , for details. Battery cabinet wiring is specified for the optimal performance of the system. Multiple battery chemistries are supported on the EXM including lithium-ion batteries.

### Maintenance Bypass Cabinet

Optional EXM Maintenance Bypass Cabinets are available. These cabinets house the components necessary to provide an external wraparound maintenance bypass switch for servicing the UPS. These cabinets are designed to be bolted to the right side of the UPS (see [Figure 3.5](#) on the next page ). Refer to the [Vertiv™ Liebert® EXM Maintenance Bypass Cabinet User Manual \(SL-25652\)](#) , for further details.

### Parallel Cabinet

The Liebert® Maintenance Bypass Cabinet provides the components for setting up two Liebert® units for parallel operation for redundant protection or to increase capacity. Refer to the [Vertiv™ Liebert® EXM Parallel Cabinet User Manual \(SL-25654\)](#) , for further details.

### System Composition

A UPS system can comprise a number of optional equipment cabinets, depending on the system design requirements. For example, the UPS Cabinet, the External Battery Cabinet and the External Bypass Cabinet. All cabinets used will be the same height and will be designed to be positioned side by side to form an aesthetically appealing equipment suite.

Figure 3.5 Cabinet Arrangement

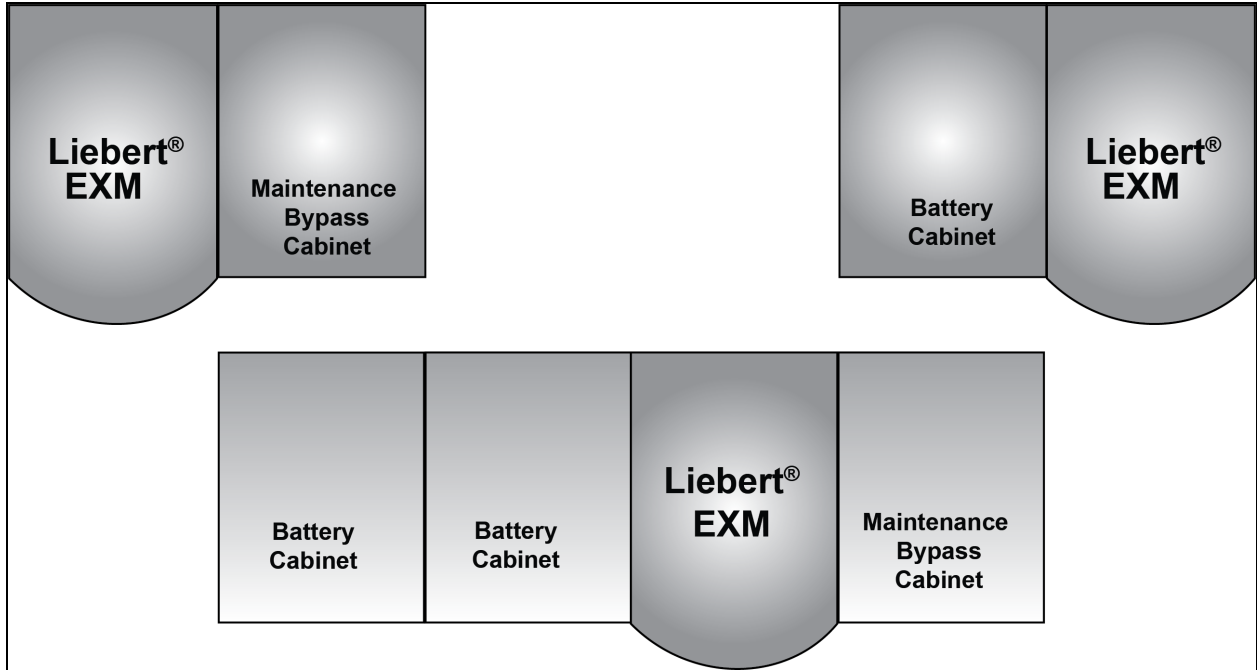

**NOTE:** All the units vieded from above. layout shown are typical. not all auxiliary cabinets are shown. refer to the submittal drawings for the exact configuration of your system.

#### Notes to Figure

1. Vertiv™ Liebert® EXM UPS connected only to the Liebert® MBC (The Vertiv™ Liebert® MBC must be on the right side of the EXM).
2. EXM connected to the Battery Cabinets (The Battery Cabinets must be on the left side of the EXM).
3. EXM connected to the Liebert® MBC (The MBC must be on the right side of the EXM).
4. EXM connected to the Battery Cabinet (The Battery Cabinets must be on the left side of the EXM).

### 3.7 Vertiv™ Liebert® Power Module Assembly

Figure 3.6 Liebert® Power Module Assembly Indicators and Controls

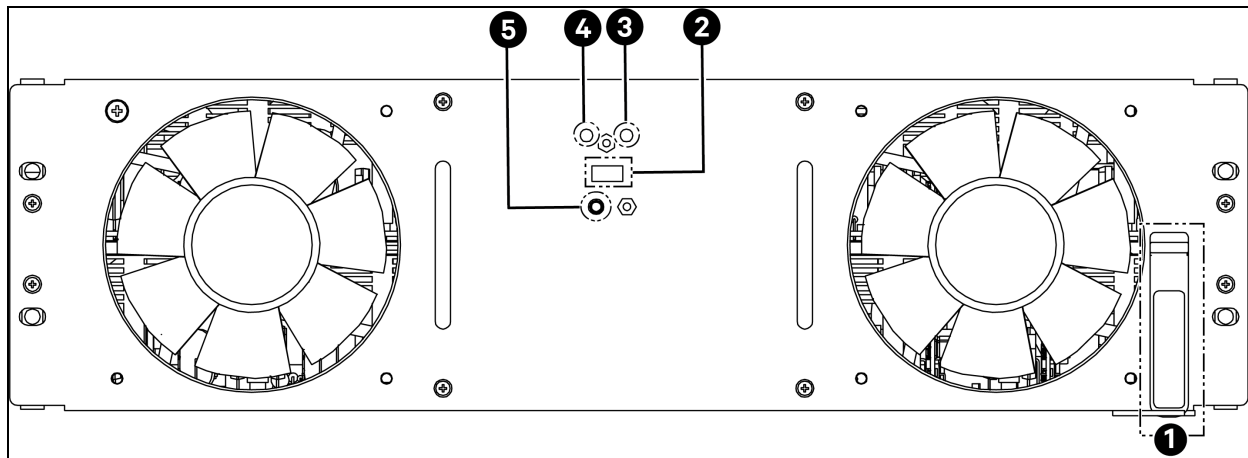

Item	Description	Item	Description
1	Ready switch	4	Fault LED
2	DIP switches	5	Battery start button
3	Run LED		

- The BATTERY START button allows starting the UPS on the battery.
- The Run LED is illuminated green when the Liebert® Power Module Assembly is operating normally.
- The Fault LED will illuminate red when the Liebert® Power Module Assembly has a problem.

Table 3.2 LED Indications

LED Status	Indication
<b>Run LED (green)</b>	
Flashing green	The inverter is starting, but has no output yet.
Constant green	The inverter has started to supply power.
OFF	The inverter has not started.
<b>Fault LED (red)</b>	
Constant red	Auxiliary power failure (15 V or 24 V), rectifier overtemperature, rectifier failure (including battery SCR short circuit), battery converter failure, soft start failure, main circuit back feed, abnormal input current, inverter failure, output short circuit, bypass SCR short circuit fault, inverter relay short circuit fault, abnormal bus voltage, module not ready, module ID out of range and duplicated module ID.
Flashing red	Charger failure, abnormal main circuit voltage, abnormal main circuit frequency, main circuit undervoltage, main circuit reverse phase, battery unavailable, reverse battery, input zero loss, current sharing failure, module overload, inverter relay disconnection fault, bypass SCR disconnection fault and input fuse blown.
OFF	No above failures or alarms.

### 3.8 Control Module

The Control Module has three Vertiv™ Liebert® EXM UPS interface card bays and connections for optional ancillary cabinets and for other options. Refer to **Figure 4.7** on page 30

**Figure 3.7 Control Module, front view**

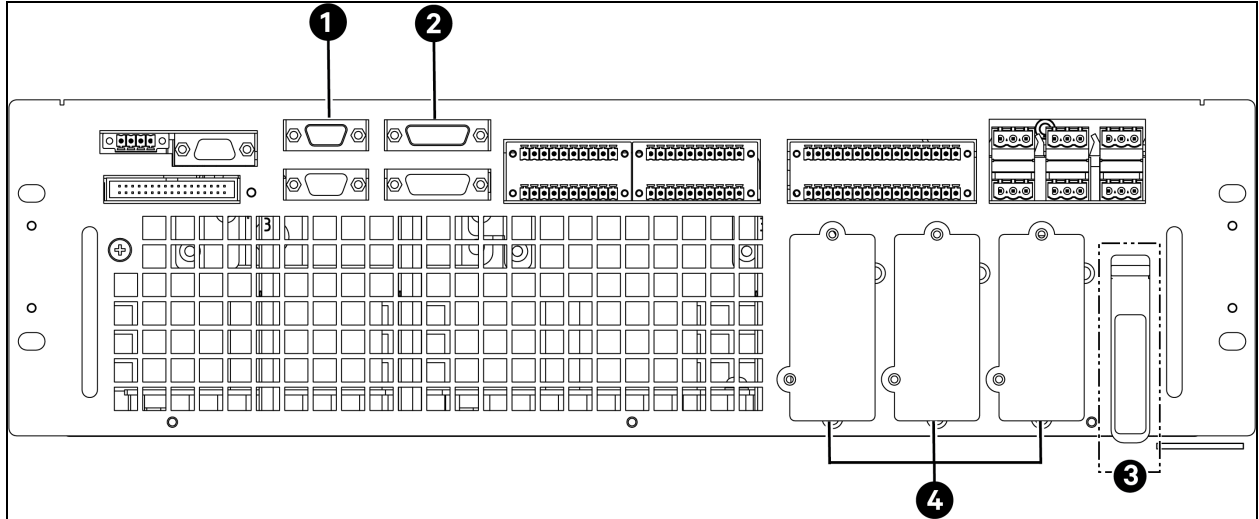

Item	Description
1	DB9
2	DB15
3	Reay switch
4	Vertiv™ Liebert® IntelliSlot™ bays 1, 2, 3

See **Figure 4.7** on page 30 for details.

### 3.9 Static Bypass Assembly

**Figure 3.8 Static Bypass Assembly connections**

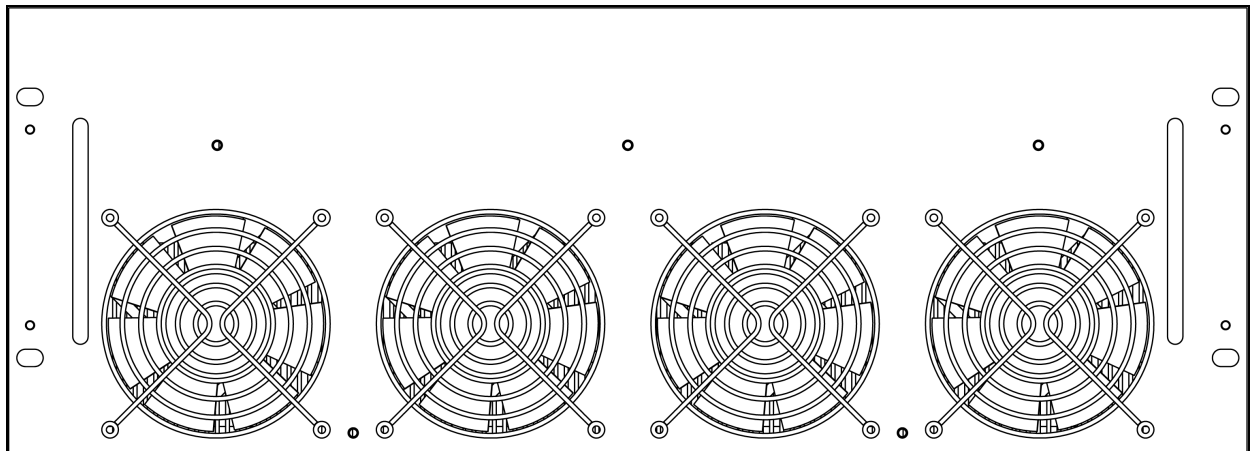

## 4 Electrical Connections UPS

The UPS requires both the power and the control cabling once it has been mechanically installed. All the control cables must run separately from the power cables in the metal conduits or the metal ducts that are electrically bonded to the metalwork of the cabinets to which they are connected.



**WARNING! Risk of electric shock. It can cause damage to the property, injury and death. Before connecting input power to the Vertiv™ Liebert® EXM UPS, ensure that you are aware of the location and the operation of the overcurrent protection devices that connect the UPS input/bypass supply to the power distribution panel. Deenergize and lockout or tag out all incoming high and low voltage power circuits before installing the cables or making any electrical connections.**

Risque de décharge électrique pouvant entraîner des dommages matériels, des blessures et même la mort. Avant de procéder au branchement de l'alimentation d'entrée du système EXM de EXM, veuillez à prendre connaissance de l'emplacement et du fonctionnement des dispositifs de protection de surintensité qui raccordent l'alimentation d'entrée ou de dérivation du système ASC au panneau de distribution électrique. Coupez l'alimentation et appliquez le verrouillage ou l'étiquetage à tous les circuits d'alimentation haute tension et basse tension avant d'installer les câbles ou d'effectuer tout autre branchement électrique.

### 4.1 Power Cabling

#### 4.1.1 Lug Size and Cable Rating

The main factors affecting the choice and the size of the cable are voltage, current (also taking into account overcurrent), room temperature and conditions of installation of the cable. Refer to the ANSI/NFPA 70.

The power cables of the system must be sized with respect to the following description:

- **UPS input cables** - The UPS input cables must be sized for the maximum input current, including the maximum battery recharge current, given in **Table 8.3** on page 64 , with respect to the unit rating and the input AC voltage.
- **UPS bypass and output cables** - The bypass and the output cables must be sized for the nominal output current, given in **Table 8.3** on page 64 , with respect to the unit rating and the output AC voltage.
- **Battery cables** - See the **Vertiv™ Liebert® EXM External Battery Cabinet User Manual (SL-25651)**, for the battery installation guidelines and the instructions. The manual is shipped with the battery cabinet and is available at Vertiv's website: [www.vertiv.com](http://www.vertiv.com).

**NOTE: Table 8.3 on page 64 , gives nominal currents for determining the size of the UPS power cables. Other important factors to consider, is to include the cable route length and the coordination with the protective devices.**

The power cables can be sized to suit the UPS unit rating according to **Table 8.3** on page 64

## Torque Requirements

Refer following tables for lug size and torque requirements.

**Table 4.1 Lug Size**

Bolt Shaft Size	lb-in. (Nm)
3/8 in. (M10)	240 (27)

**Table 4.2 Torque Requirements**

AWG Wire Size or Range	lb-in. (Nm)
#22 - #14	3.5 to 5.3 (0.4 to 0.6)

## 4.2 External Protective Devices

For safety concerns, it is necessary to install the external circuit breakers or other protective devices for the input AC supply of the UPS system. This section provides generic practical information for the qualified installation engineers. The installation engineers should be knowledgeable about regulatory wiring standards and the equipment to be installed.

To reduce the risk of fire, connect only to a circuit provided with branch circuit overcurrent protection in accordance with the NEC ANSI/NFPA 70.

### 4.2.1 Rectifier and Bypass Input Supply of the UPS

#### Overcurrents

Install the suitable protective devices in the distribution unit of the incoming mains supply, considering the power cable current-carrying capacity and overload capacity of the system. Generally, the magnetic circuit breaker with IEC60947-2 tripping curve C (normal) at the 125% of the nominal current listed in **Table 8.3** on page 64 is recommended.

**Split bypass:** In case a split bypass is used, a separate protective devices should be installed for the rectifier input and the bypass input in the incoming mains distribution panel. A shunt trip coil of 120 V must be installed in the bypass input breaker, if the system does not include a Vertiv™ Liebert® EXM Bypass Cabinet. Refer to the **Figure 4.1** on the facing page for more details.

**NOTE:** The rectifier input and the bypass input must use the same neutral line.

#### Earth Leakage, RCD Devices

Any Residual Current Detector (RCD) installed upstream of the UPS input supply:

- Must be sensitive to DC unidirectional pulses (Class A)
- Must be insensitive to transient current pulses, and
- Must have an average sensitivity, adjustable between 0.3 A and 1 A.

To avoid false alarms, the earth leakage monitoring devices (when used in the systems with the split bypass input or when used in parallel UPS configurations) must be located upstream of the common neutral sinking point. Alternatively, the device must monitor the combined four-wire rectifier and the split bypass input currents.

## 4.2.2 UPS Output

If an external distribution panel is used for the load distribution, the selection of the protective devices must provide discrimination with those that are used at the input to the UPS **Table 8.7** on page 66

## 4.2.3 UPS Input Configuration

By default, the Vertiv™ Liebert® EXM UPS which is shipped with the internal links installed between the bypass input and the main (rectifier) input (single input configuration).

**Figure 4.1** below and **Figure 4.2** on the next page show the EXM in a split bypass (single source dual input) configuration. In this configuration, the static bypass and the maintenance bypass lines are supplied by the same source using separate feeds. Both the feeds must be protected externally with properly sized protective devices.

### Wire Liebert® EXM Input as a Single Source Dual-Input

To wire the EXM as a single source dual-input UPS, remove the factory installed links between the rectifier and the bypass input busbar (see **Figure 4.3** on page 24 ).

**Figure 4.1 Single UPS Block Diagram—Dual Input, Single Source Configuration (without Bypass Cabinet)**

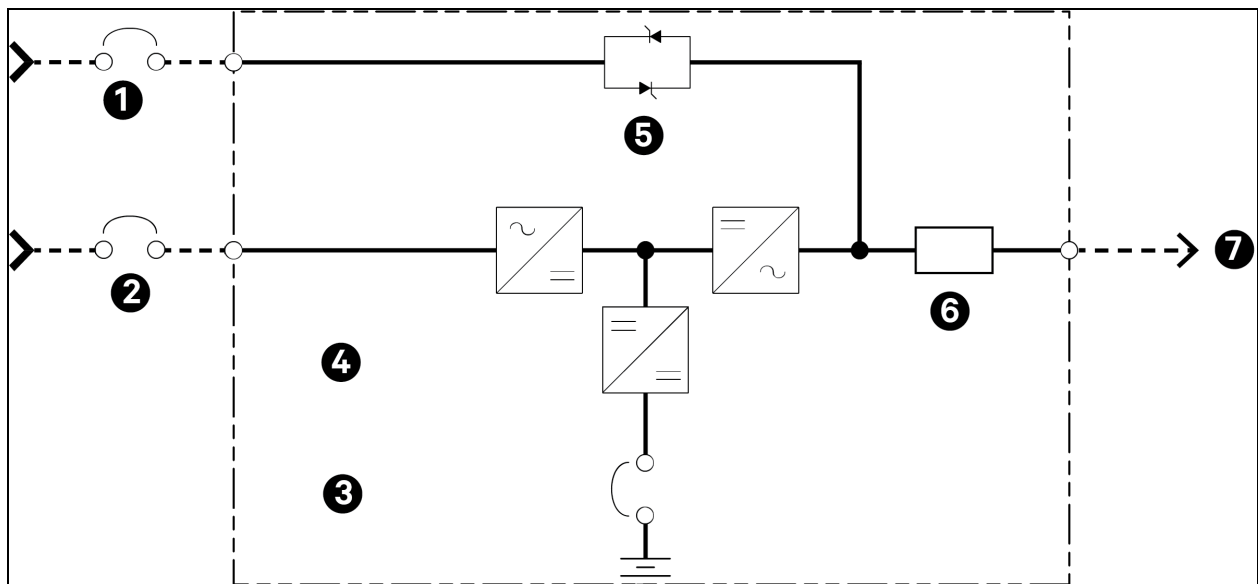

#### Notes to Figure

1. Install in accordance with the national and the local electrical codes.
2. The input and the bypass must share the same single source.
3. A neutral is required from the system AC input source. Vertiv recommends a full capacity neutral conductor and grounding conductors.
4. The bypass and the rectifier input and output cables must be run in the separate conduits.
5. The control wiring must be run in the separate conduits.
6. The customer must supply shunt trip breakers with 120 V coils to the bypass.



Item	Description	Item	Description
1	Bypass AC input 4-wire + GND	7	MBC - Maintenance Bypass Cabinet
2	Rectifier AC input 4-wire + GND	8	MBB - Maintenance Bypass Cabinet
3	Battery	9	MIB - Maintenance Isolation Breaker
4	UPS cabinet	10	Output bus
5	Static bypass	11	AC output 208 V 4-wire + GND
6	BIB - Bypass Isolation Breaker		
* External overcurrent protection by others.			

#### 4.2.4 Cabling Guidelines

The following are the guidelines only and are superseded by the local regulations and codes of practice where applicable. Use wiring rated at 75 °C or greater.

1. Take special care when determining the size of the neutral cable, as the current circulating on the neutral cable may be greater than the nominal current in the case of non-linear loads. Refer to the values in [UPS Electrical Characteristics](#) on page 64 .
2. The ground conductor should be sized according to such factors as the fault rating, the cable lengths and the type of protection. The ground cable connecting the UPS to the main ground system must follow the most direct route possible. The control wiring and the power wiring must be run in the separate conduit. the output and the input cables must be run in the separate conduit.
3. Consider using paralleled smaller cables for heavy currents; this can ease installation.
4. Refer to the [Vertiv™ Liebert® EXM External Battery Cabinet User Manual \(SL-25651\)](#), which is shipped with the battery cabinet and is available at Vertiv's website: [www.vertiv.com](http://www.vertiv.com) for guidelines and instructions when sizing the battery cables.
5. In most installations, the load equipment is connected to a distribution network of individually protected busbars fed by the UPS output, rather than connected directly to the UPS itself. When this is the case, the UPS output cables can be rated to suit the individual distribution network demands rather than being fully load-rated.

**NOTE: If more load is added to the distribution panel, the cabling of the unit must be resized.**

6. When laying the power cables, do not form coils; this will help avoid increasing formation of electromagnetic interference.

#### 4.2.5 Cable Connections

The rectifier input and output, the bypass and the battery are easily accessible from the front of the unit for installation. All require lug type terminations. They are connected to the busbars on the front of the Vertiv™ EXM, as shown in [Figure 4.3](#) on the next page . These busbars are accessible when the Input/Output panel is removed.

##### NOTICE

Risk of improper installation. It can cause damage to the equipment. When wiring a single input only system, connect only the power wiring to the input busbars.

**Figure 4.3 Input Busbars - Vertiv™ Liebert® EXM 20-200 kVA frame**

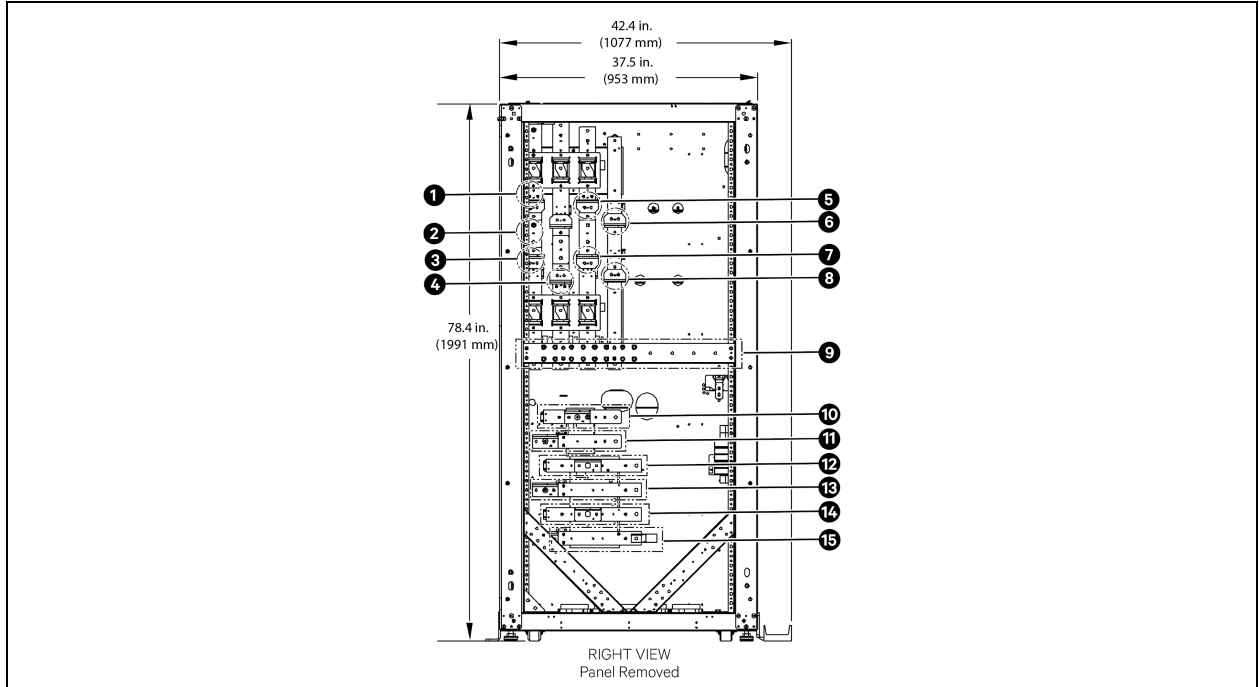

Item	Description	Item	Description
1	Bypass input A and bypass input B	9	Ground busbar
2	Single input link A/B/C	10	Battery +
3	Rectifier input A	11	Battery -
4	Rectifier input B	12	Output N
5	Bypass input C	13	Output phase A
6	Input N	14	Output phase B
7	Rectifier input C	15	Output phase C
8	Battery N		

### 4.2.6 Accessory Fuses and Back Feed Breaker Wiring

Two fuse blocks provide power for the back feed breakers (standard) and the BDSUi (optional). The fuse blocks are at the lower right of the I/O panel on the front of the Vertiv™ Liebert® EXM UPS. For fuse holder locations (see **Figure 4.4** on the facing page).

The back feed breaker fuse block, provides 120 V nominal provided from the UPS output (L-N) and the fuse is rated for 2 amps. **Figure 4.5** on page 26 shows the back feed breaker wiring, located on the bypass static switch assembly.

The EXM does not include internal back feed protection. A shunt trip coil of 120 V must be installed in the shunt trip. The shunt trip is required for both, the rectifier input breaker and the bypass input breaker if the system does not include a Vertiv™ Liebert® Bypass Cabinet. This is a safety feature and will prevent EXM UPS inverter from back feeding the input source.

The BDSUi fuse block provides 208 V nominal from the EXM UPS output (L-L) and the fuse is rated at 8 A. The BDSUi power wiring is shown in the [Vertiv™ Liebert® EXM External Battery Cabinet User Manual \(SL-25651\)](#).

**Figure 4.4 Accessory Fuses**

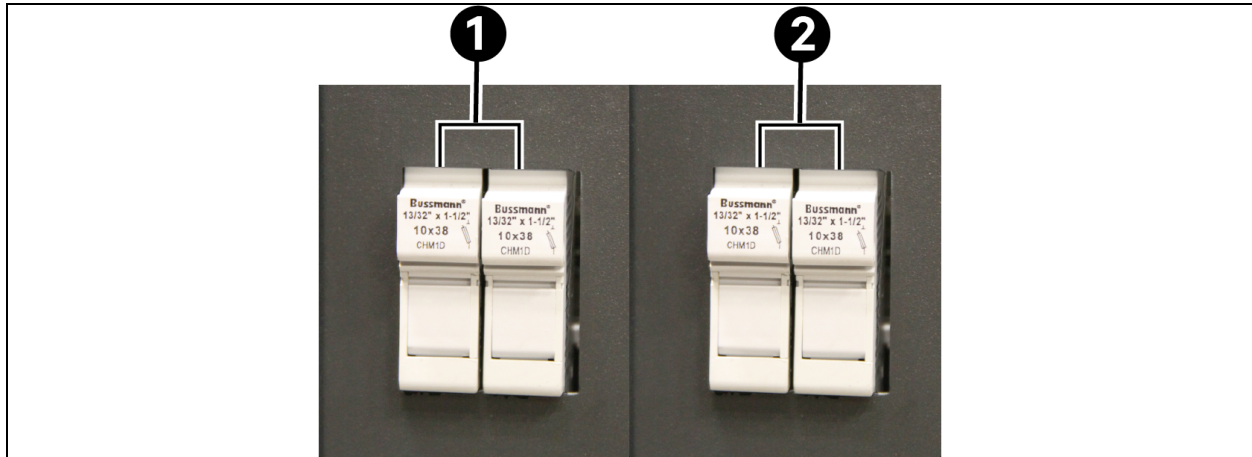

Item	Description
1	Back-feed breaker FH1
2	BDSUi FH2 (optional)

Figure 4.5 Dual Input Back feed Breaker Wiring when Maintenance Bypass Cabinet Not in Use

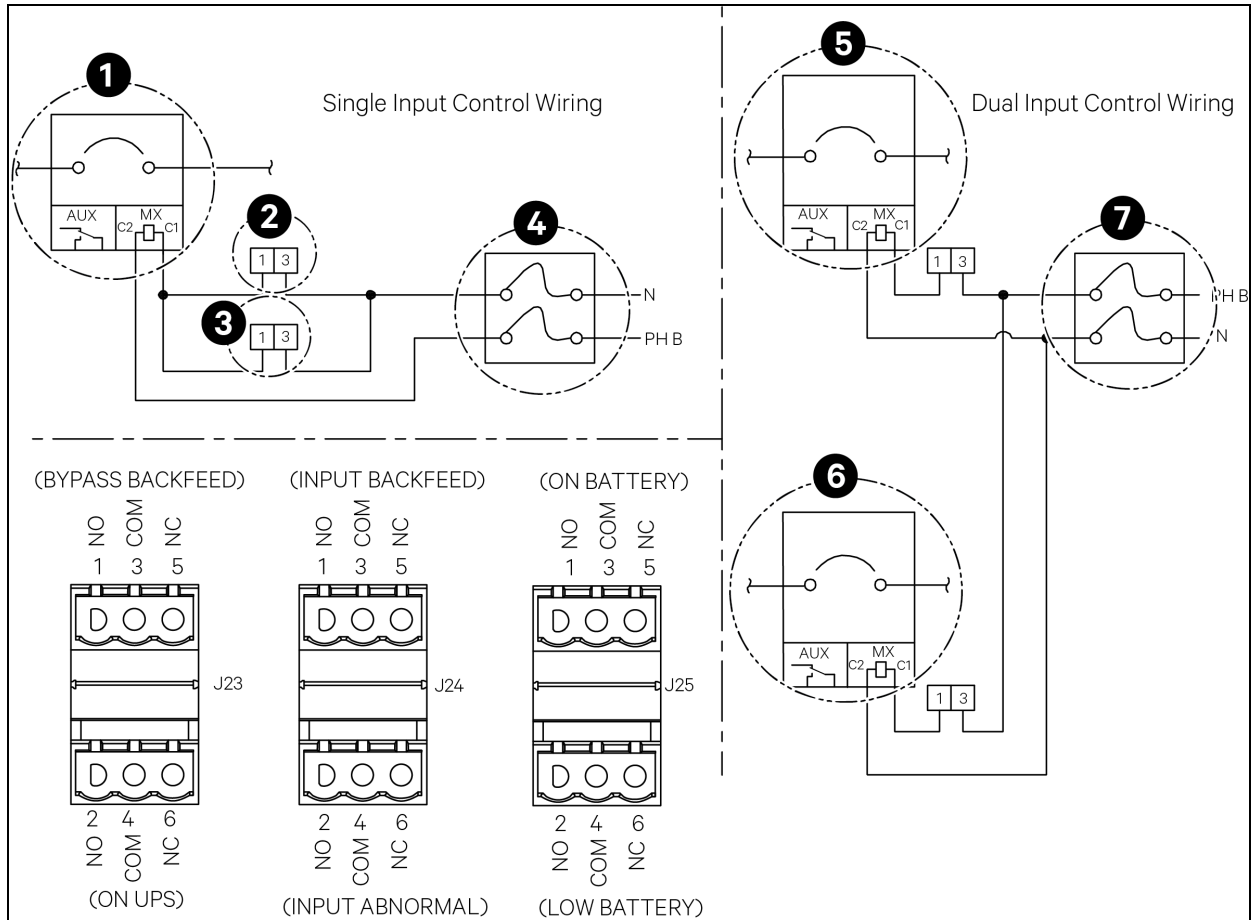

Notes to Figure

1. Auxiliary contacts not needed for the back feed breaker operation.
2. A 120 V shunt trip coil is required for the proper operation.

Item	Description
1	Upstream system input breaker
2	J23
3	J24
4	Backfeed breaker fuse block (FH1)
5	Upstream bypass input breaker
6	Upstream rectifier input breaker, optional
7	Backfeed breaker fuse block (FH1)

**NOTE:** Shunt trips are required in the upstream breakers to allow back feed protection to function properly. Shunt trip of the upstream rectifier input breaker and the bypass input breaker is optional.

## 4.2.7 Safety Ground

The safety ground busbar is below the neutral input and the output busbars as shown in **Figure 4.6** below . The safety ground cable must be connected to the ground busbar and bonded to each of the cabinet in the system. This ground busbar is then connected to the ground electrode conductor (GEC).

All the cabinets and the cable conduit should be grounded in accordance with local regulations.



**WARNING! Risk of electrical shock and arc flash. It can cause damage to the property, injury and death. Failure to follow proper grounding procedures can result in electric shock hazard to personnel or the risk of fire, should a ground fault occur.**

Le non-respect des procédures de mise à la terre peut entraîner des risques d'électrocution du personnel, ou des risques d'incendie en cas de défectuosité de la mise à la terre. Toutes les opérations décrites dans cette section ne doivent être effectuées que par des électriciens ou des techniciens professionnels dûment formés et qualifiés. En cas de difficultés, communiquez avec Vertiv. Pour obtenir les renseignements de contact, consultez la dernière page de ce manuel.

**NOTE: Proper grounding significantly reduce the problems caused by the electromagnetic interference.**

**NOTE: The ground and the neutral busbars are easily accessible when the I/O panel is removed. The cable connections should be made before a cabinet is attached to the right side of the Vertiv™ Liebert® EXM UPS or before the UPS is placed where another obstruction, such as a wall, is against the right side of the EXM.**

**Figure 4.6 Ground and Neutral Busbar Connections - 20-200 kVA Frame Busbars**

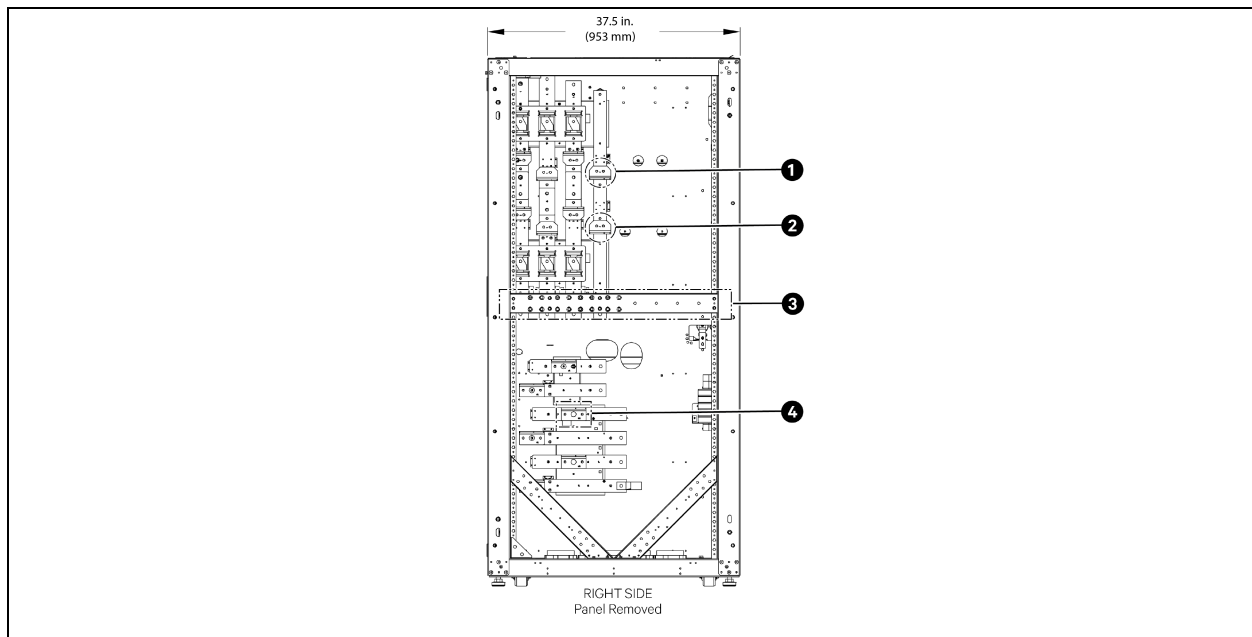

Item	Description
1	Input neutral
2	Battery neutral
3	Ground busbar
4	Output neutral

## 4.2.8 Protective Devices

For safety, it is necessary to install the circuit breakers in the input AC supply, external to the UPS system. Given that every installation has its own characteristics, this section provides guidelines for the qualified installation engineers with knowledge of operating practices, regulatory standards and the equipment to be installed.

### UPS Rectifier and Bypass Input Supply

Protection from the excessive overcurrents and the short circuits in the power supply input.

The external overcurrent protection for the AC output circuit is to be provided. See [UPS Electrical Characteristics](#) on page 64 and [Table 8.9](#) on page 67 for overload capacity.

The overcurrent protection for the battery circuit must be provided by the customer when using an external battery cabinet not manufactured by Vertiv.

### Dual Input Single Source

When wiring the UPS with a dual input or with a single input source, the Rectifier input and the Bypass input must be protected separately. Size the breakers according to the input currents shown in [Table 8.3](#) on page 64

**NOTE: For a single or a dual input, a 120 V shunt trip coil(s) is required when a breaker is supplied by the customer. See [Figure 4.2](#) on page 22 for details.**

### Fuses

The Vertiv™ Liebert® EXM main input and the bypass input busbars are equipped with fuses at 6 locations; (see [Figure 5.1](#) on page 39 ). The type is Bussman 170M6466, rated at 1250 A.

### System Output

When using an external distribution panel for load distribution, the output neutral and the input neutral must be separated at the input to the UPS.

## 4.2.9 Cabling Procedure



**CAUTION: The operations described in this section must be performed by the authorized electricians or the qualified technical personnel. If you have any difficulties, contact your local Vertiv representative or Vertiv Services.**

Toutes les opérations décrites dans cette section ne doivent être effectuées que par des électriciens ou des techniciens professionnels dûment formés et qualifiés. En cas de difficultés, communiquez avec Vertiv. Pour obtenir les renseignements de contact, consultez la dernière page de ce manuel.

**NOTE: The hydraulic pressure pliers, the combinative tools and the piston ring pliers should be used to connect the AC wiring.**

Once the equipment has been positioned and secured for operation, and the battery and the ground lugs have been connected (see [Cable Connections](#) on page 23 ), connect the power cables as described below. Study the reference drawing [Figure 5.1](#) on page 39 .

1. Verify that all the incoming high and low voltage power circuits are de-energized and locked out or tagged out before installing the cables or making any electrical connections.
2. Remove the front I/O panel to gain easier access to the connections busbars.

3. Connect the facility ground and the ancillary ground bus cables to the copper ground busbar located in the middle of the Liebert® EXM behind the output connections. All the cabinets in the UPS system must be connected to the ground connection provided by the customer.

**NOTE: The grounding and the neutral bonding arrangement must comply with the National Electrical Code and all the applicable local codes.**

4. Identify and make the power connections with the incoming cables according to Step 5 through Step 8.

### Common Input Connections

5. For the common bypass and the main inputs, connect the AC input supply cables to the UPS input terminals (A2-B2-C2-N1) and tighten the connections to 240 lb-in. (27 Nm) (M10 bolt). Ensure the correct phase rotation.

**NOTE: For the common bypass and the main inputs, the AC input cables must be connected to the bypass terminal (A2-B2-C2-N1) but not the main input terminal (A2-B2-C2).**

### Split Bypass Connections

6. If a split bypass configuration is used, connect the AC input supply cables to the rectifier input terminals (A1-B1-C1-N1) and connect the AC bypass supply cables to the bypass input terminals (A2 B2 C2-N1) and tighten the connections to 240 lb -in. (27 Nm) (M10 bolt). Ensure the correct phase rotation.

**NOTE: For the split bypass operation, ensure that the busbars between the bypass and the rectifier inputs are removed. The neutral line of the bypass input must be connected to that of the rectifier input.**

### Output System Connections - Ensure Correct Phase Rotation

7. Connect the system output cables between the UPS output busbars (A-B-C N terminals) and the critical load and tighten the connections to 240 lb -in. (27 Nm) (M10 bolt).



**WARNING! Risk of electrical shock and arc flash. It can cause damage to the property, injury and death. If the load equipment will not be ready to accept the power when the commissioning engineer arrives, ensure that the system output cables are safely isolated.**

Risque de décharge électrique pouvant causer des blessures graves, voire mortelles. Si les équipements branchés ne sont pas prêts à être alimentés à l'arrivée de l'ingénieur de mise en service, assurez vous que les bornes des câbles de sortie du système soient isolées de façon sécuritaire.

Observe the battery cable polarity. Be sure that the battery connections, if any, are made with the correct polarity.

8. Refit all protective covers removed for cable installation.

## 4.3 Control Cables Details

### 4.3.1 Static Bypass Assembly Features

Based on your site's specific needs, the Vertiv™ Liebert® EXM UPS may require auxiliary connections to manage the battery system (the external battery circuit breaker, the battery temperature sensor), communicate with a personal computer or provide alarm signaling to the external devices or for the Remote Emergency Power Off (REPO). Terminations for these functions are located at the front of the static bypass assembly. The main features are:

- Input and output dry contacts signal (one pair of contacts of relay)
- Emergency power off control (EPO)

- Environmental parameter input interface
- User communication (for data setting and user background monitor)
- Vertiv™ Liebert® IntelliSlot™ interface
- Temperature detect interface

Figure 4.7 Control Module Connections to Display Cabinet and Options

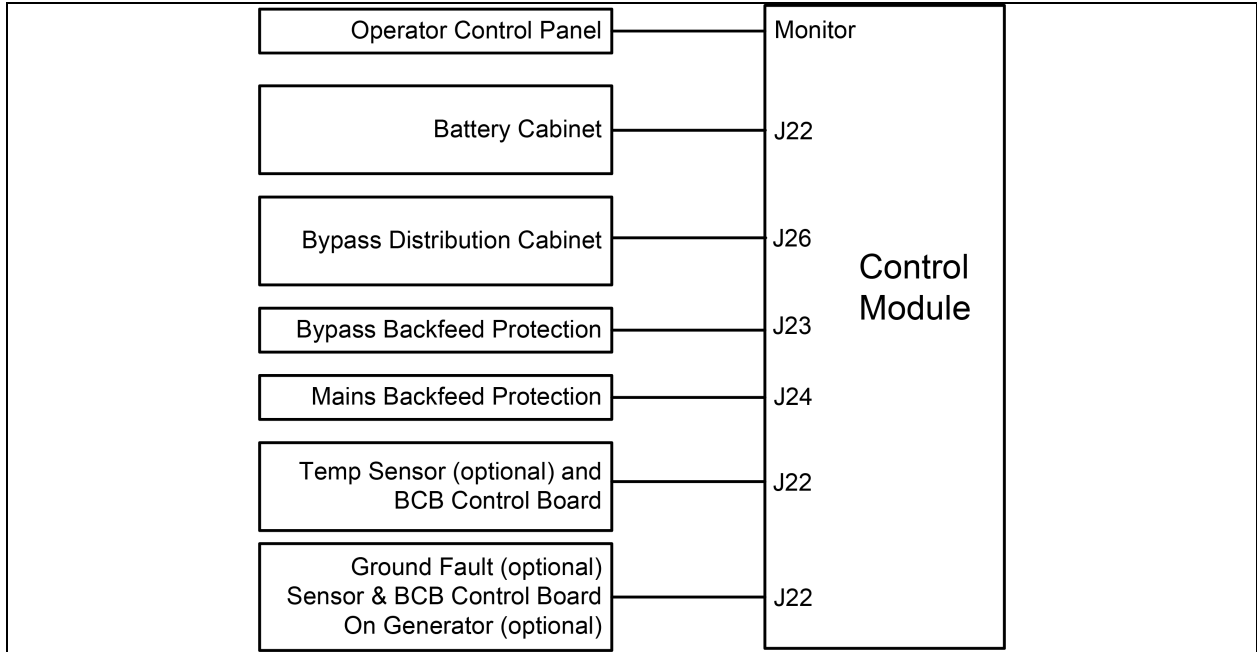
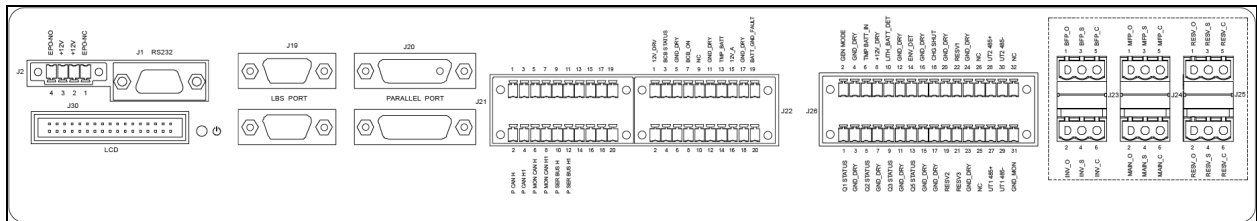

Figure 4.8 Dry Contact Terminal Block Detail (Control Module Front Panel)



## 4.4 Dry Contacts

The UPS provides the input dry contacts and the output dry contacts on the auxiliary terminal block (dry contact terminal block).

### 4.4.1 Input Dry Contacts

The external input dry contacts are connected via the dry contact terminal block. Dry contacts are available for environment detection, battery ground fault detection, etc.

The UPS accepts the external signal from zero voltage (dry) contacts connected through the external dry contact terminals produced, and these terminals are on the static bypass assembly. Through software programming, these signals become active when these contacts connect to +12 V to ground (in the most left side). The cables connected to the monitor board must be separated from the power cables. Moreover, these cables should be double insulated with a typical cross-section of 0.5 to 1 mm<sup>2</sup> for a maximum connection length between 82 ft and 165 ft (25 m-50 m). The Dry Contact Terminal Block has several input dry contacts.

**Figure 4.9 Input Dry Contacts**

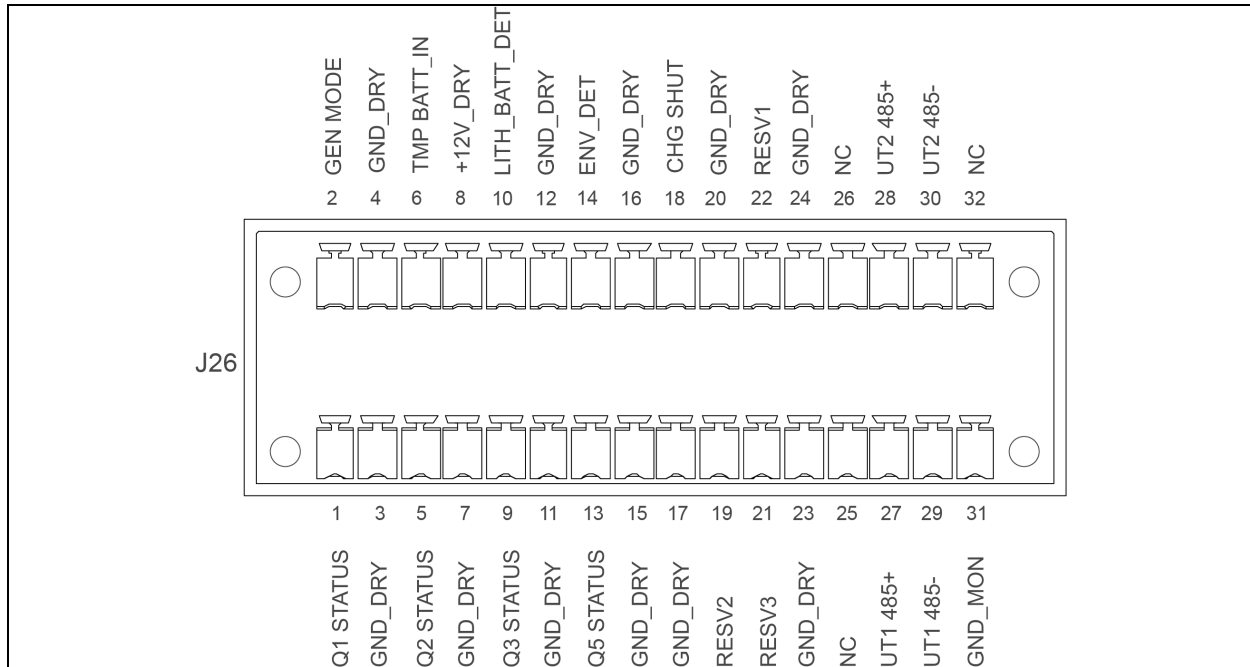

**Table 4.3 Input Dry Contacts - J26**

Pin	Name	Description	Pin	Name	Description
1	RIB_STATUS	Rectifier input breaker status (short for RIB closed)	2	GEN_MODE	Generator mode (N.O.)
3	GND_DRY	Dry ground	4	GND_DRY	Dry ground
5	BIB_STATUS	Bypass input breaker status (short for BIB closed)	6	TMP_BATT_IN	Battery temperature
7	GND_DRY	Dry ground	8	+12 V_DRY	+12 V power
9	LEGACY_MBB	Legacy maintenance bypass breaker status (Open for MBB closed)	10	—	N/A
11	GND_DRY	Dry ground	12	GND_DRY	Dry ground
13	LEGACY_MIB	Legacy maintenance isolation breaker status (Short for MIB closed)	14	ENV_DET	Environment room temperature (N.O.)
15	GND_DRY	Dry ground	16	GND_DRY	Dry ground
17	GND_DRY	Dry ground	18	CHG_SHUT	Charger shutdown (N.O.)

**Table 4.3 Input Dry Contacts - J26 (continued)**

Pin	Name	Description	Pin	Name	Description
19	MIB_STATUS	Maintenance isolation breaker status (Open for MIB closed)	20	GND_DRY	Dry ground
21	MBB_STATUS	Maintenance bypass breaker status (Short for MBB closed)	22	MOB_STATUS	Module output breaker (MOB) status (Open for MOB closed)
23	GND_DRY	Dry ground	24	GND_DRY	Dry ground
25	—	N/A	26	—	N/A
27	UT1_485+	RS485+ Channel #1	28	UT2_485+	RS485+ Channel #2
29	UT1_485-	RS485+ Channel #1	30	UT2_485-	RS485+ Channel #2
31	GND_MON	Monitor ground	32	—	N/A

### 4.4.2 Output Dry Contacts

The Dry Contact Terminal Block has three output dry contact relays (see **Figure 4.10** below and **Table 4.4** below).

**Figure 4.10 Output Dry Contacts and EPO Wiring**

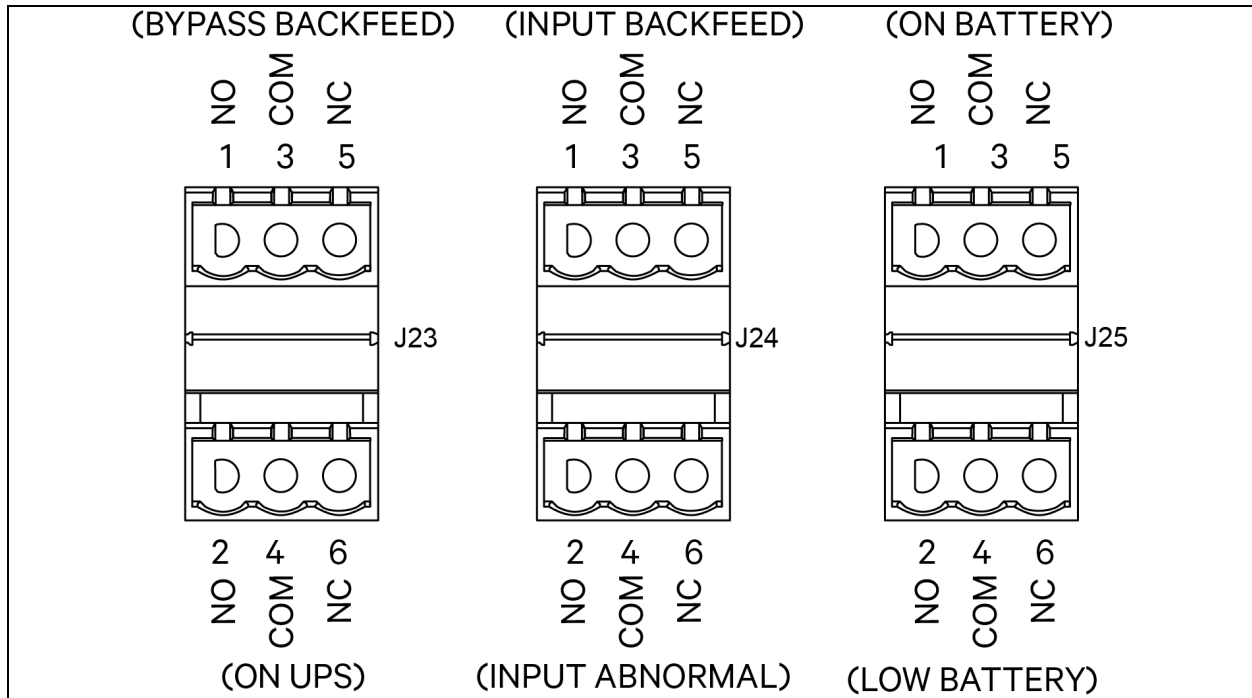

**Table 4.4 Output Dry Contact Relays**

Port	Pin	Description	Port	Pin	Description
J23	1	Bypass backfeed NO	J24	2	Input abnormal NO
	3	Bypass backfeed COM		4	Input abnormal COM
	5	Bypass backfeed NC		6	Input abnormal NC

**Table 4.4 Output Dry Contact Relays (continued)**

Port	Pin	Description	Port	Pin	Description
J23	2	On UPS NO	J25	1	On battery NO
	4	On UPS COM		3	On battery COM
	6	On UPS NC		5	On battery NC
J24	1	Input backfeed NO	J25	2	Low battery NC
	3	Input backfeed COM		4	Low battery COM
	5	Input backfeed NC		6	Low battery NC

**NOTE:** All the auxiliary cables of the terminal must be double insulated. The wire should be 20 AWG-16 AWG stranded for maximum runs between 80 ft and 200 ft (25 m-60 m), respectively.

**NOTE:** Refer to the Vertiv™ Liebert® EXM Maintenance Bypass Cabinet Manual (SL-25652) for the EXM MBC Wiring.

### 4.4.3 Vertiv™ Liebert® EXM MBC Interface

The Liebert® EXM MBC Interface is on the Dry Contact Terminal Block at J26. Refer to 3.9 for circuit details.

**NOTE:** All the auxiliary cables of the terminal must be double insulated. The wire should be 20 AWG-16 AWG stranded for maximum runs between 80 ft and 200 ft (25 m-60 m), respectively.

**NOTE:** Refer to the Vertiv™ Liebert® EXM Maintenance Bypass Cabinet Manual (SL-25652) for the EXM MBC Wiring.

### 4.4.4 Battery Cabinet Interface Connectors

The battery cabinet interface is on the Dry Contact Terminal Block at J22. Refer to [Dry Contacts](#) on page 30 for circuit details.

Figure 4.11 Output Dry Contacts and EPO Wiring

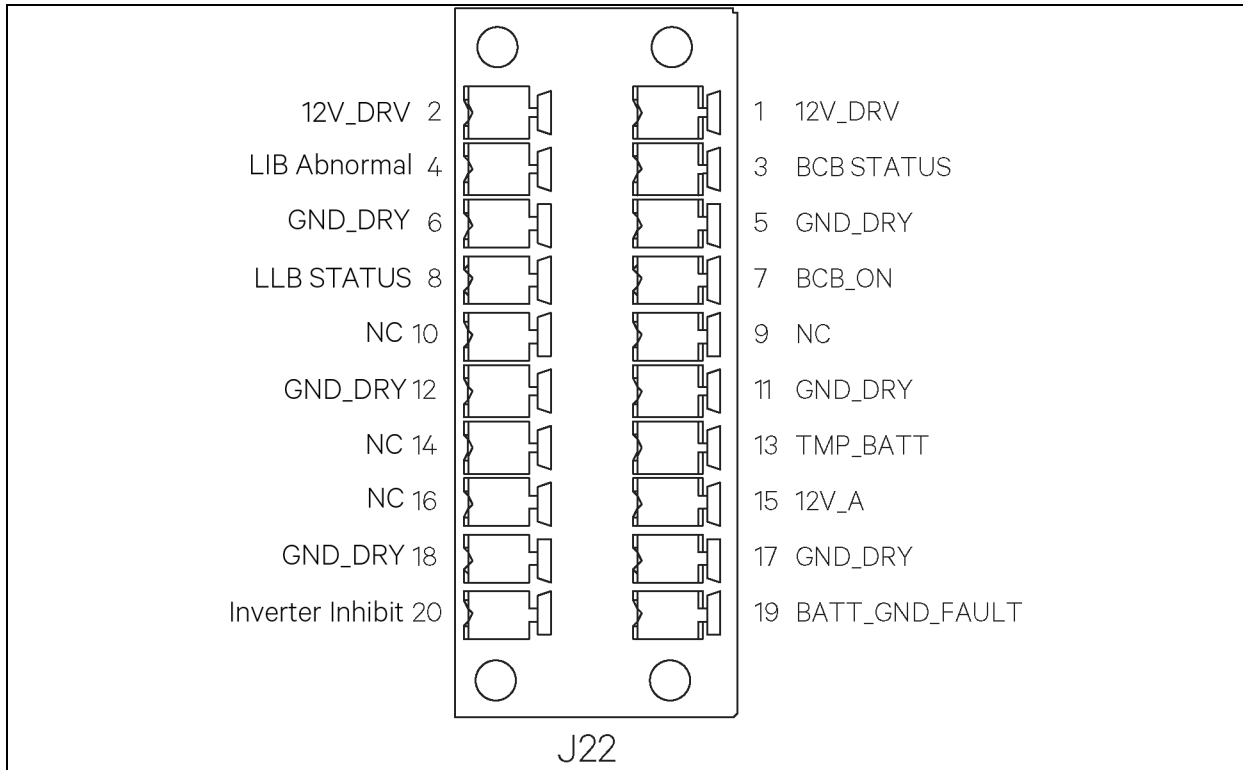

Table 4.5 Battery Cabinet Interface J22

Pin	Name	Description
1	12V_DRV	BCB driver signal
2	12V_DRV	BCB drive, 12 V to trip BCB
3	BCB STATUS	BCB state signal
4	LIB Abnormal	Lithium-Ion battery system operates abnormally
5	GND_DRY	Dry ground
6	GND_DRY	Dry ground
7	BCB_ON	BCB on line signal
8	LLB STATUS	Aux status of local load bank breaker for single/each unit testing.
9	NC	NC
10	NC	NC
11	GND_DRY	Dry ground
12	GND_DRY	Dry ground
13	TMP_BATT	External battery temperature
14	NC	NC
15	12 V_A	Power

**Table 4.5 Battery Cabinet Interface J22 (continued)**

Pin	Name	Description
16	NC	NC
17	GND_DRY	Dry ground
18	GND_DRY	Dry ground
19	BATT_GND_FAULT	Battery ground fault signal
20	Inverter Inhibit	To turn off the inverter, often used with maintenance interlock devices.

The pins of J22 are configurable in software. Pins 3, 4, 7, 8, 19, 20 can be configured to any of the inputs shown. The pins shown in the table above are the default inputs. There are additional inputs that can be configured in the table below.

**Table 4.6 J22 Additional Pin Assignments**

Name	Description
Battery Trip Request	External request to trip the battery breaker
BCB2 Status	BCB state signal for BCB2
BCB2_ON	BCB on line signal for BCB2
BATT_GND_FAULT 2	Battery ground fault signal for battery string 2
SLBB Status	Aux status of system load bank breaker for parallel systems

**NOTE: All the auxiliary cables of the terminal must be double insulated. The wire should be 20 AWG-16 AWG stranded for maximum runs between 80 ft and 200 ft (25 m-60 m), respectively.**

#### 4.4.5 EPO Input-Optional

##### NOTICE

Risk of exceeding the internal voltage limits. It can cause damage to the equipment. Do not apply more than 12 V to the Emergency Power Off (EPO) input. Exceeding 12 V on this input can damage the internal circuitry of the Vertiv™ Liebert® EXM UPS and control boards. Exceeding 12 V will also put the Liebert® EXM in an EPO state, and the unit will not reset, making it non-functional.

The UPS has EPO function operated by a button on the control panel or by a remote contact provided by the user. The EPO button is under a hinged, clear plastic shield.

The J2 connector, shown in **Figure 4.12** on the next page, is the remote EPO input interface. The EPO has Normally Open or Normally Closed (NO/NC) contacts that become active when shorting the terminals J2: 3 and J2: 4 or open the terminal connections J2: 2 and J2: 1.

If an external Emergency Stop capability is required, it is connected at terminals J2: 1 and J2: 2 and at J2: 3 and J2: 4 on the monitor board. It is also connected to the NO/NC remote stop switch between these two terminals using shielded cable (see **Figure 4.12** on the next page and **Table 4.7** on the next page). If this function is not used, the terminals J2: 3 and J2: 4 must be opened and J2: 1 and 2 must be closed.

Figure 4.12 EPO Wiring and Signal Names for J2

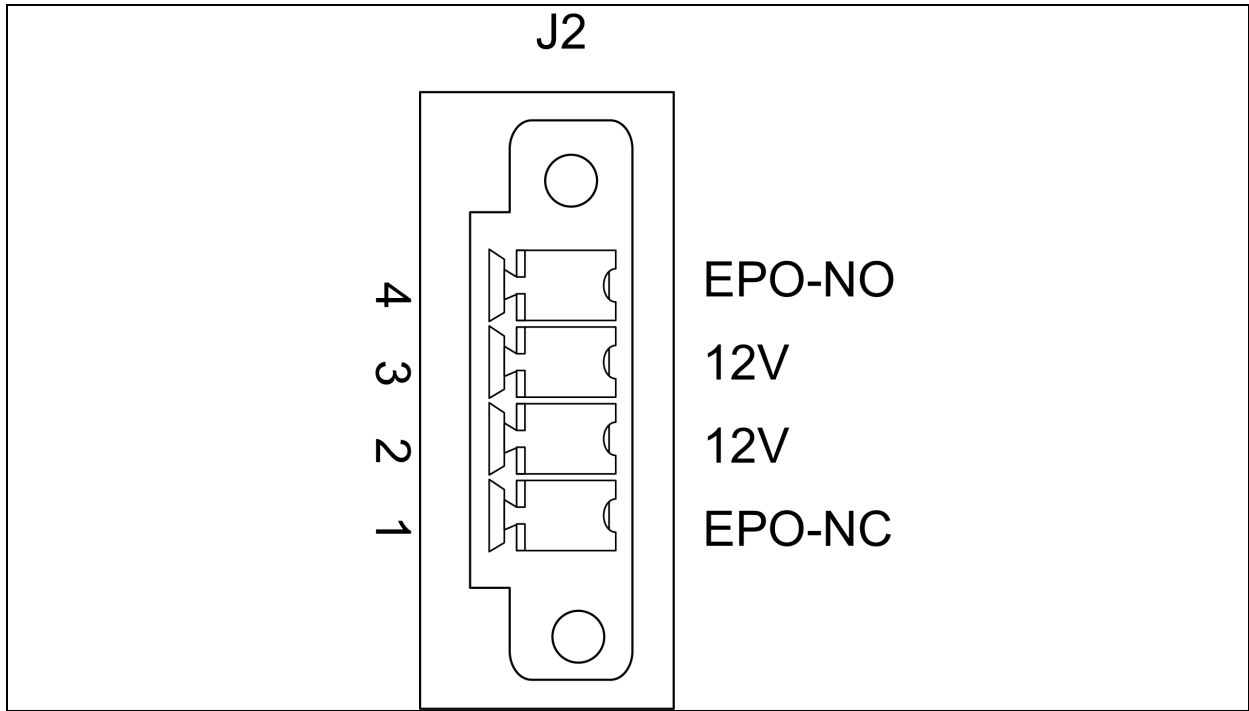

Table 4.7 EPO Input Contact Relays - J2

Pin	Name	Description	Pin	Name	Description
1	EPO-NC	EPO activated when opened to Pin 2	3	+ 12 V	—
2	+ 12 V	—	4	EPO-NO	EPO activated when shorted to Pin 3

**NOTE:** The Emergency stop action within the UPS shuts down the rectifier, the inverter and the static bypass. It does not internally disconnect the input power supply. To disconnect ALL power to the UPS, open the upstream feeder breaker(s) after the remote EPO is activated.

**NOTE:** Normally Closed EPO–J2: 12, these terminals are supplied factory linked on the Bypass Module on the UPS and must remain installed if using NO contacts.

**NOTE:** All the auxiliary cables of the terminal must be double insulated. The wire should be 20 AWG-16 AWG stranded for maximum runs between 80 ft and 200 ft (25 m-60 m), respectively.

Figure 4.13 Single UPS Remote Emergency Power Off

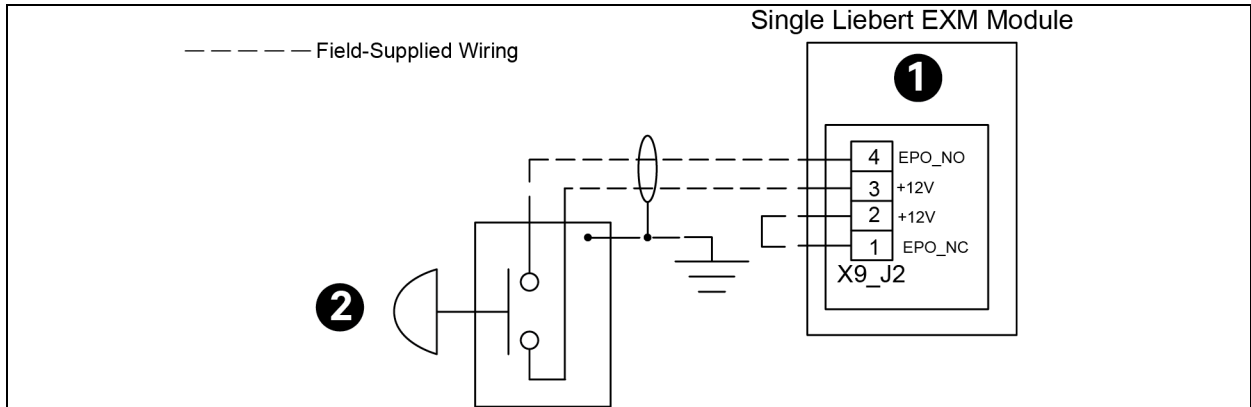

Item	Description
1	Single Liebert® EXM module
2	Remote emergency power Off

## 4.5 Parallel Cable Connections

Figure 4.14 Parallel Cable Wiring Diagram

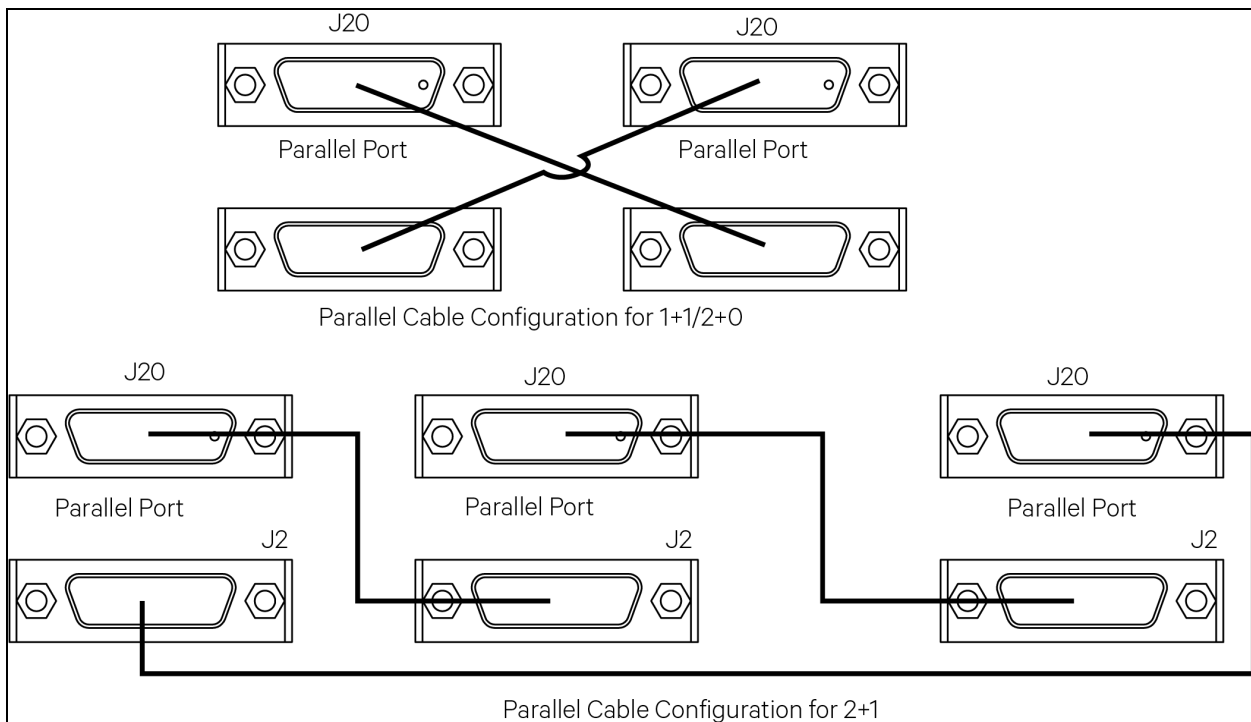

This page intentionally left blank

## 5 Installation Drawings

The diagrams in this section illustrate the key mechanical and electrical characteristics of the Vertiv™ Liebert® EXM UPS System Cabinets (UPS, Liebert® EXM MBC and battery).

**Figure 5.1 Installation Drawing**

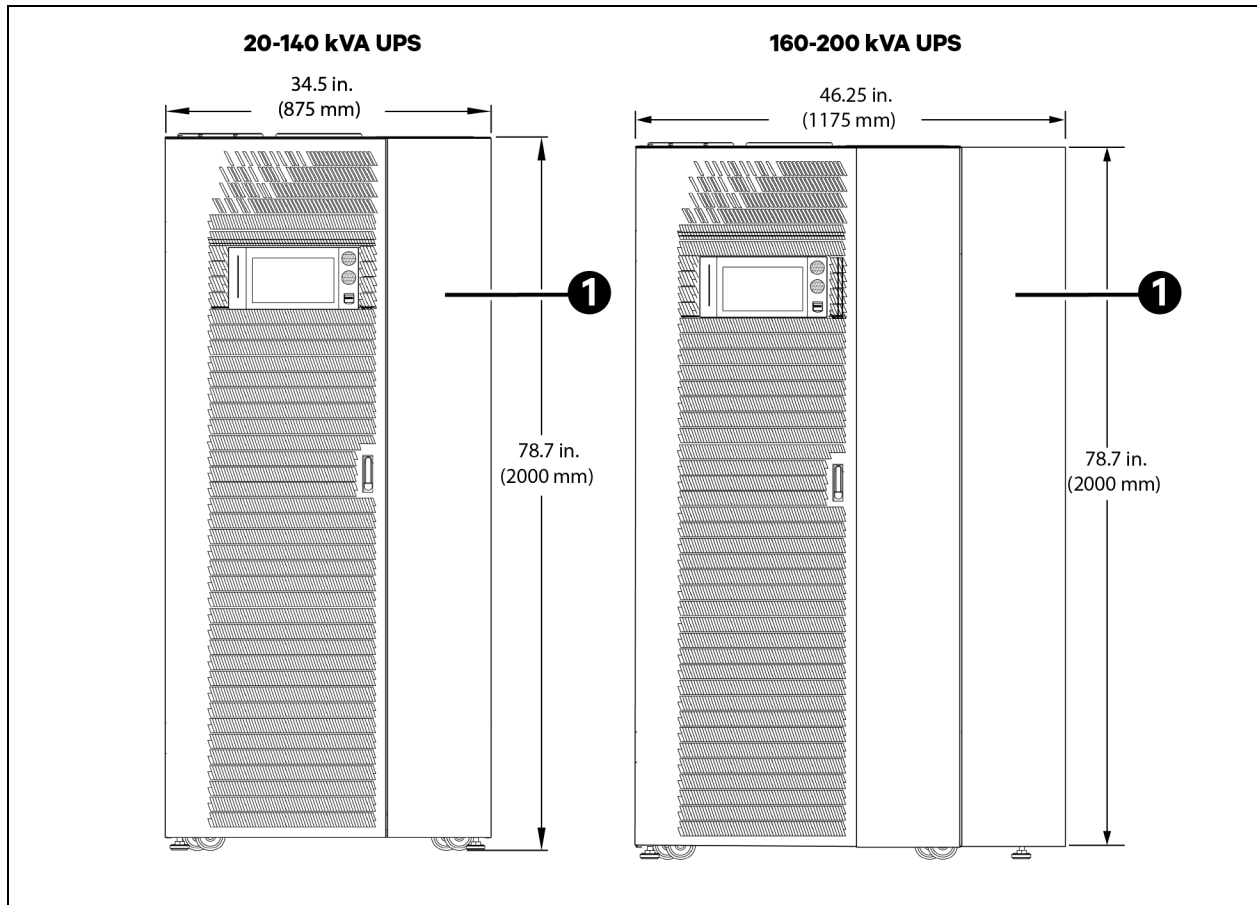

### Notes to Figure

1. Dimensions are in in. (mm).
2. 24 in. (610 mm) minimum clearance above the unit required for air exhaust. No clearance required in the rear except when using seismic anchoring, allow 5 in. (127 mm) clearance. 36 in. (914 mm) front access required for service.
3. Keep the cabinet within 15 degrees of vertical.
4. The top and the bottom cable entries are available through the removable access plates. Remove, punch to suit the conduit size and replace.
5. Unit bottom is structurally adequate for forklift handling.
6. The control wiring and the power wiring must be run in the separate conduits
7. All the wiring is to be in accordance with the national and the local electrical codes.
8. All the battery cabinets must be positioned on the left side of the UPS.

Item	Description
1	Wiring Cabinet

Figure 5.2 UPS Main Components-Typical 20-200 kVA Unit

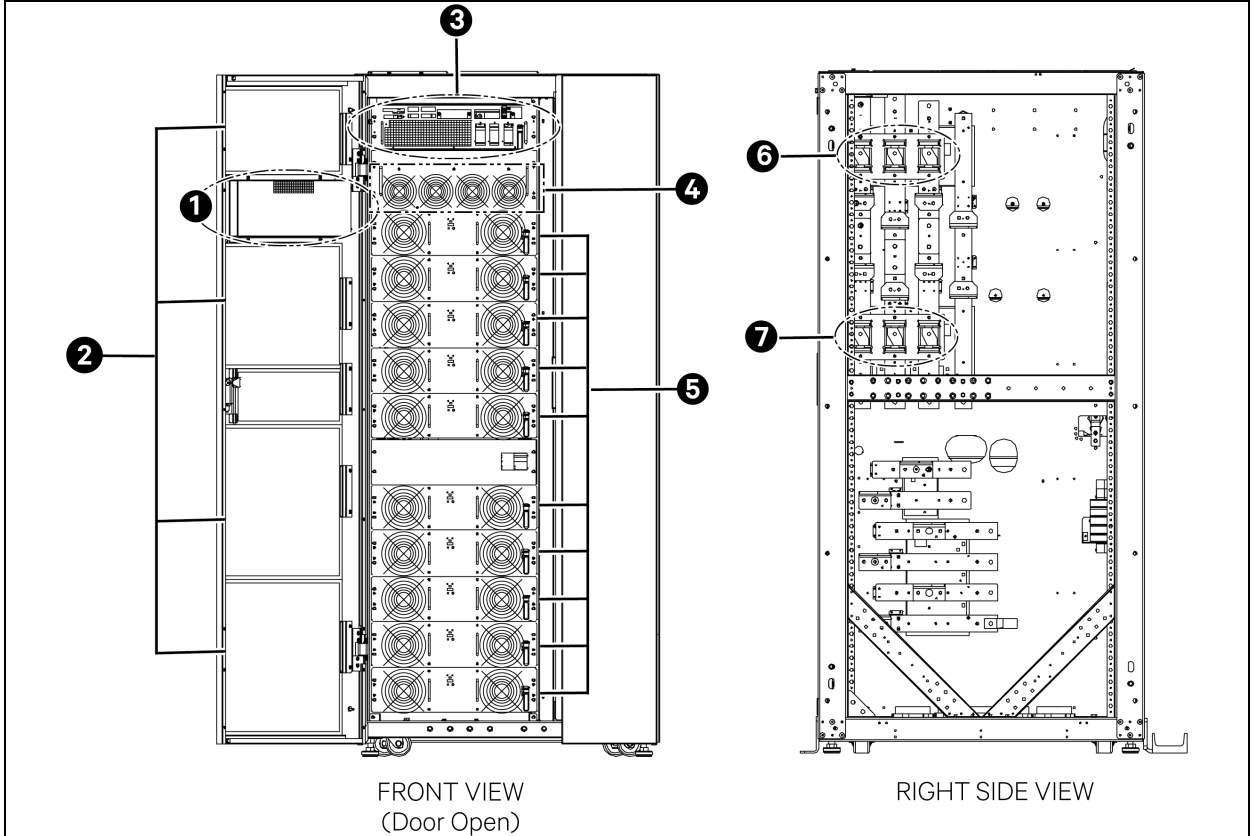

Item	Description
1	Control panel
2	Replaceable air filter
3	Control module
4	Static bypass assembly
5	Power module
6	Bypass input fuses
7	Main input fuses

Figure 5.3 UPS Cable Connections - 20-200 kVA Frames

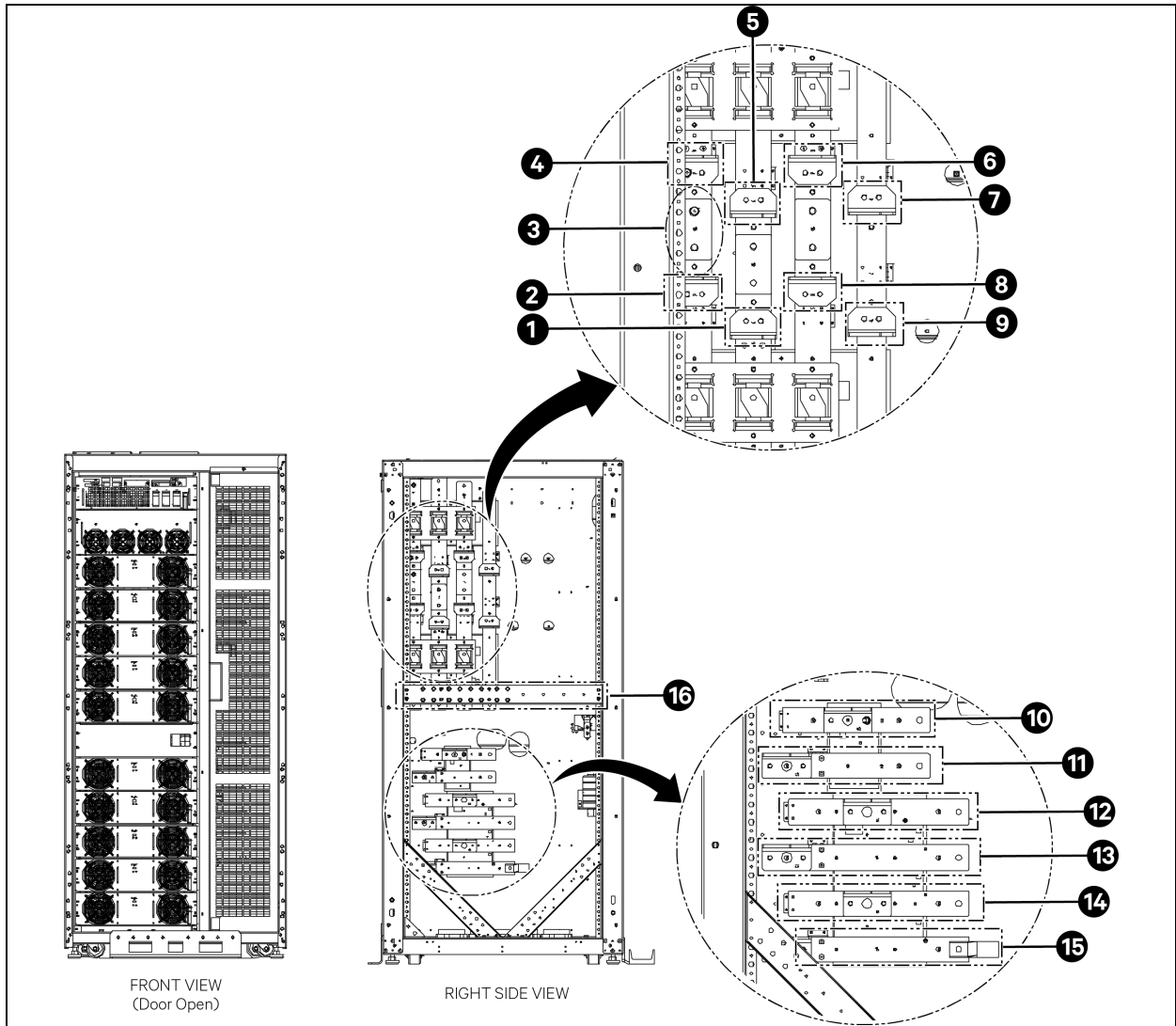

Item	Description	Item	Description
1	Rectifier input B	9	Battery neutral
2	Rectifier input A	10	Battery positive
3	Single input jumpers ( remove for dual input configurations)	11	Battery negative
4	Bypass input A	12	Output neutral
5	Bypass input B	13	Output phase A
6	Bypass input C	14	Output phase B
7	Input neutral	15	Output phase C
8	Rectifier input C	16	Ground busbar

This page intentionally left blank

## 6 Option Installation

### 6.1 Vertiv™ Liebert® IntelliSlot™ Communication

The Vertiv™ Liebert® EXM UPS has three Liebert® IntelliSlot™ ports to allow field installation of the optional communication cards. Liebert® IntelliSlot™ cards communicate using Liebert's proprietary Velocity protocol to cards that translate the information into such protocols as SNMP and Modbus. Other cards provide dry contact signals for external signaling of operating status.

The Liebert® IntelliSlot™ communication ports may be installed or removed while the EXM is operating.

### 6.2 Liebert® IntelliSlot™ Web Card - SNMP/HTTP Network Interface Card

This network interface card provides all real time data and the status information as SNMPv1 traps for connection to a 10/100-base T-Ethernet connection. The same card also will transmit the same status information and all measured parameters for displaying via a web browser. The Liebert® IntelliSlot™ bays are on the right side of the control module and labeled as IntelliSlot1, IntelliSlot2 and IntelliSlot3.

**Table 6.1 EXM Communication Options**

Port Type and Location	Labeled ID Name of Port	Monitoring Devices Supported
Left Liebert® IntelliSlot™	IntelliSlot 1	IS-Relay
		IS-Unity-DP
		IS-Unity-LIFE
		IS-485EXI
Center Liebert® IntelliSlot™	IntelliSlot 2	IS-Relay
		IS-Unity-DP
		IS-Unity-LIFE
		IS-485EXI
Right Liebert® IntelliSlot™	IntelliSlot 3	IS-Relay
		IS-Unity-DP
		IS-Unity-LIFE
		IS-485EXI

#### 6.2.1 Liebert® IntelliSlot™ Unity Cards - IS-UNITY-LIFE, IS-UNITY-S, IS-UNITY-DP

**IS-UNITY-LIFE:** This standard card is used for communication between the Liebert® EXM and Vertiv™ Liebert® *Trellis*™ NMS and Vertiv™ LIFE™ services.

**IS-UNITY-DP:** This card can be used instead of the standard card if communication to two third party platforms is required. Third-party platforms include SNMP and 485 (Modbus/Bacnet) protocols. This card would still be used for communication between the EXM and the Vertiv's Liebert® *Trellis*™ NMS and Vertiv™ LIFE™ Services. All communication protocols are active simultaneously.

**Liebert® IntelliSlot™ Dry Contact Card (IS-RELAY):** Provides the dry contact alarm information, including: On Battery, On Bypass, Low Battery, Summary Alarm, UPS Fault and On UPS signals for communication to a remote monitoring system.

**IS-485EXI:** The Vertiv™ Liebert® IntelliSlot™ 485 EXI Card provides connection to a Vertiv™ Liebert® SiteScan™ allowing Liebert® SiteScan™ Web 4.0 monitoring and control of your Liebert equipment.

### 6.3 Liebert® IntelliSlot™ Web Card (Optional)

An optional web card that is available that provides remote access to the UPS. A wide variety of status and the summary information is available through an Ethernet connection.

Figure 6.1 Liebert® IntelliSlot™ Web Card Display

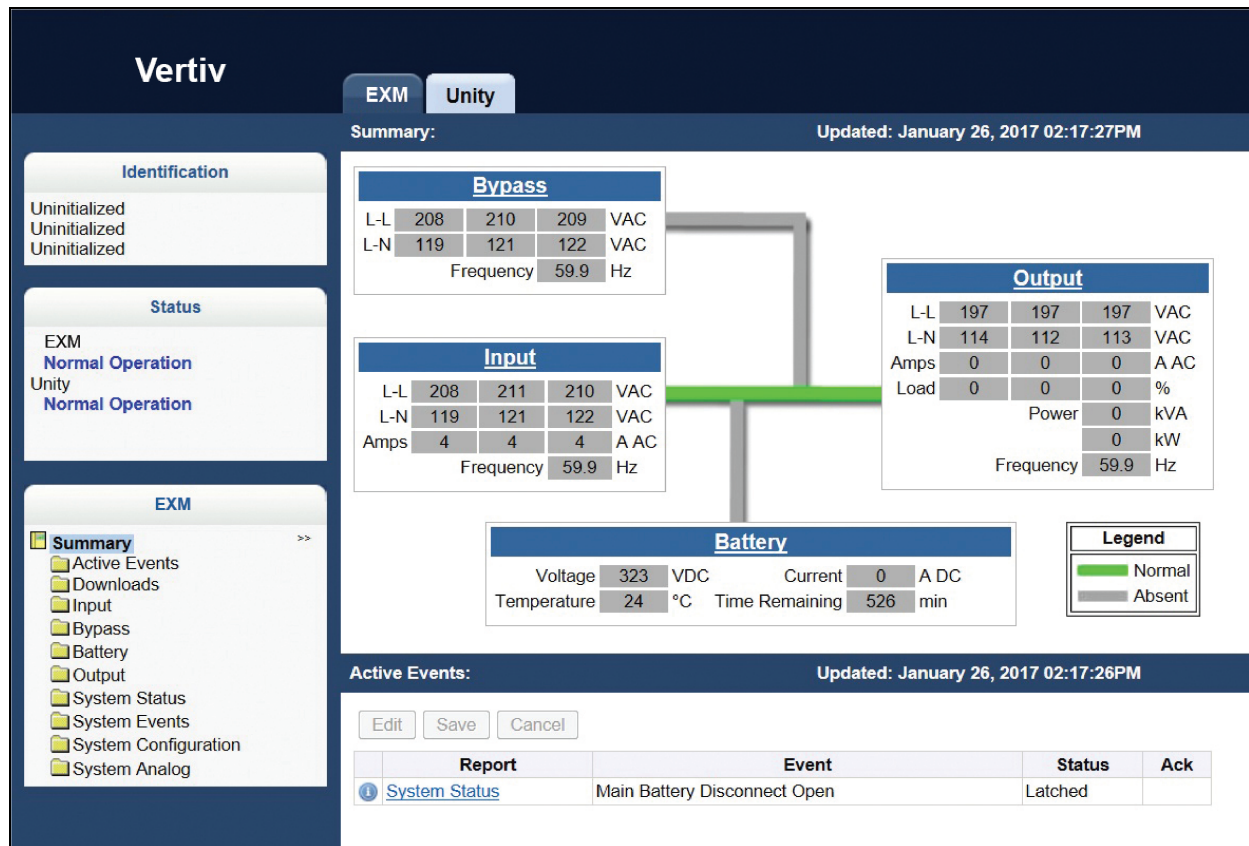

### 6.4 Liebert® IntelliSlot™ Relay Card

The Liebert® IntelliSlot™ Relay Card (IS-RELAY) provides voltage free contact closures for remote monitoring of alarm conditions.

Delivering On Battery, On Bypass, Low Battery, Summary Alarm, UPS Fault and On UPS signals, the easy to install card integrates with AS/400 computers (additional cable required) and other relay contact monitoring systems.

The relay card is rated for 24 VAC/DC at 1 A. and supported in any of the three Liebert® IntelliSlot™ bays on the Vertiv™ Liebert® EXM UPS.

### 6.4.1 Liebert® IntelliSlot™ Relay Card Pin Configuration

The card has two terminals blocks, TB1 (green, numbered 1-9) and TB2 (black, 10-18), as shown in **Figure 6.2** below .

**Figure 6.2** Pin Location and Numbering

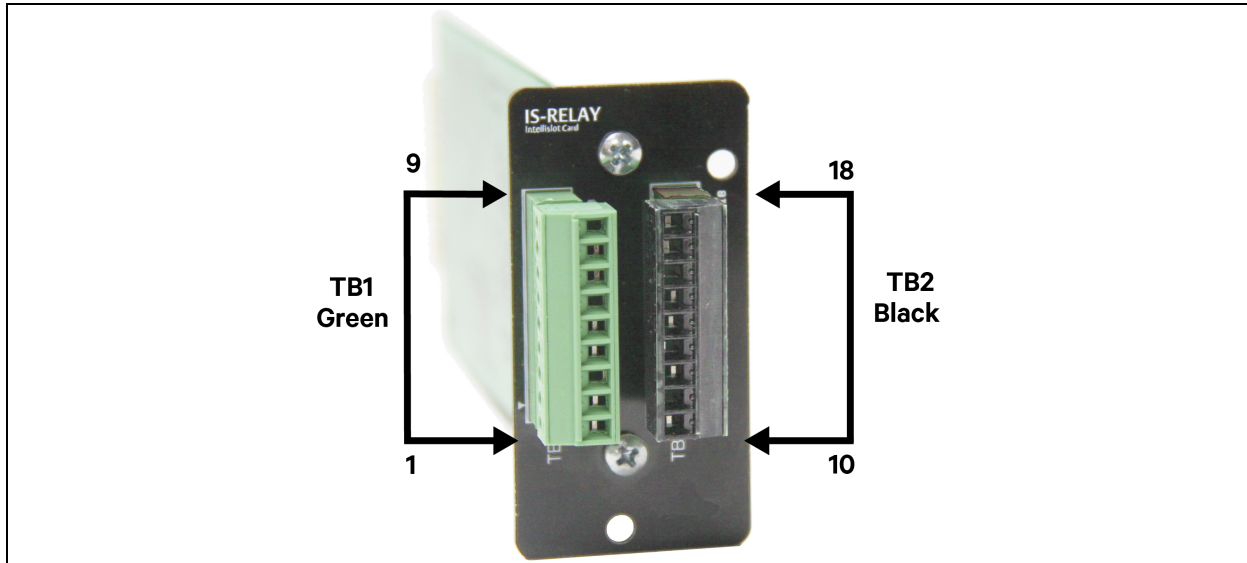

Refer to your Liebert product user manual for the pin configuration for the terminal blocks.

**Table 6.2** Relay Card Pin Configuration

Pin	Function	Operation	Pin	Function	Operation
1	Common - Low battery	—	10	Not used	—
2	Low battery	Closed if low battery point occurs.	11	Not used	—
3	Low battery	Closed if battery is OK	12	Not used	—
4	Common - UPS fault	—	13	Summary alarm*	Closed if no alarm conditions are present
5	UPS fault	Closed if UPS fault occurs	14	Summary alarm*	Closed if summary alarm occurs
6	UPS fault	Closed if no UPS failure	15	Common - summary alarm*	—
7	Common - On Battery	—	16	On UPS	Closed if On UPS (inverter) power
8	On Battery	Closed if On Battery power (Utility failure)	17	On Bypass	Closed if On Bypass
9	On Battery	Closed if not On Battery power (Utility OK)	18	Common - On Bypass	—

### 6.4.2 Vertiv™ Liebert® IntelliSlot™ Relay Card Jumper Setup

The Liebert® IntelliSlot™ Relay Card has five jumpers, P3 through P7, as shown in **Figure 6.3** on the next page . Each jumper connects two pins.

Figure 6.3 Jumper Location and Numbering

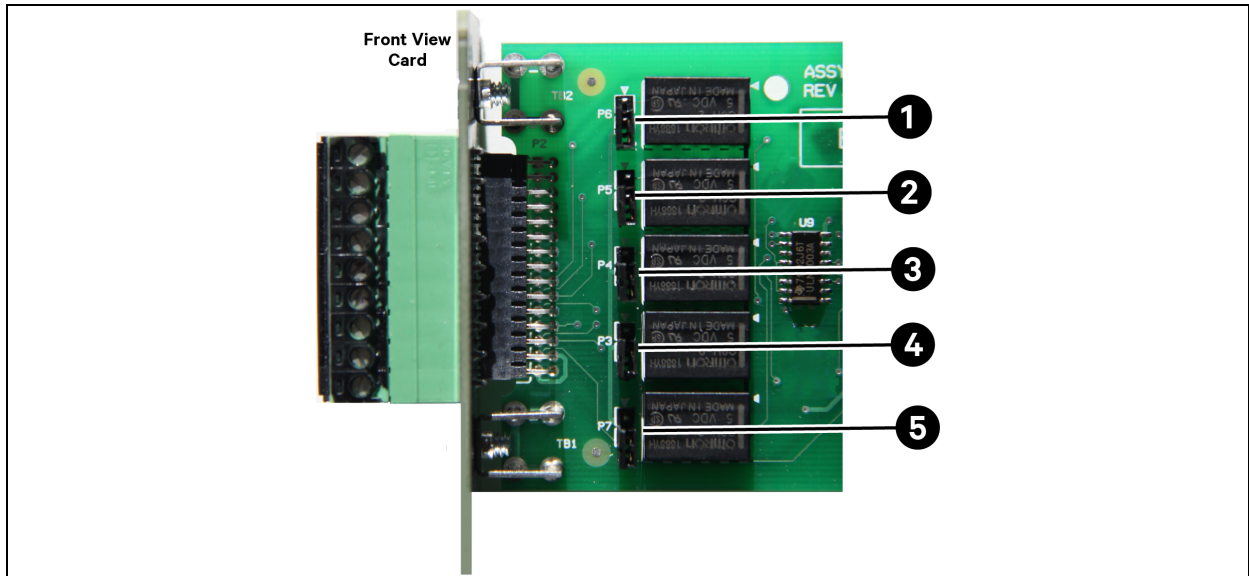

Table 6.3 Jumper Connections

Item	Jumper	Relay
1	P6	On battery
2	P5	UPS fault
3	P4	Low battery
4	P3	On bypass
5	P7	Summary alarm

By default, all five jumpers have shunts installed. The two pins are shunted together to provide the functions shown in **Table 6.3** above, allowing the relay commons to be tied together.

The jumpers should be removed if there is any external voltage source that may intentionally or inadvertently be connected to the relay.

Removing the shunt from any two pins breaks the connection between the relay commons so they are not tied together.

**NOTE:** Refer to the Vertiv™ Liebert® IntelliSlot™ Relay Card Manual, (SL-23211) for additional details. The document is available at Vertiv's website: [www.vertiv.com](http://www.vertiv.com)

## 7 Operation



**WARNING! Risk of electrical shock. It can cause personal injury or death. This UPS has several circuits that are energized with high DC as well as AC voltages. Check for voltage with both AC and DC voltmeters before working within the UPS. Check for the voltage with both AC and DC voltmeters before making the contact. Only properly trained and qualified personnel wearing appropriate safety headgear, gloves, shoes and glasses should be involved in installing the UPS or preparing the UPS for installation. When performing the maintenance with any part of the equipment under power, the service personnel and the test equipment should be standing on rubber mats.**

Risque de décharge électrique pouvant causer des blessures graves, voire mortelles. Ce système ASC comporte plusieurs circuits à haute tension c.a et c.c. Vérifiez les tensions au moyen de voltmètres c.a. et c.c. avant d'utiliser le système ASC. Vérifiez les tensions avec des voltmètres c.a. et c.c. avant d'établir tout contact. Seuls des employés qualifiés et dûment formés portant un casque, des gants, des chaussures et des lunettes de sécurité adéquats doivent se charger d'installer le système ASC ou de le préparer pour l'installation. Les responsables de l'entretien et l'équipement d'essai doivent reposer sur des tapis de caoutchouc lors de toute intervention sur une pièce d'équipement sous tension.

The Vertiv™ Liebert® EXM UPS operates in the modes shown in [Vertiv™ Liebert® EXM Operating Modes](#) on the next page . This section describes various kinds of the operating procedures under each operating mode, including transfer between the operating modes, the UPS setting and the procedures for turning On/Off inverter. As shown in the **EXM Battery Cabinet Manual (SL-25656)**, the AC utility source is supplied through the input breaker, and the rectifier converts the alternating current into DC power. The inverter converts the AC power from the utility or the DC power from an optional External Battery Cabinet into AC power for the load. The batteries power the load through the inverter in the event of a power failure. The utility source can also power the load through the static bypass. If the maintenance or repair of the UPS is necessary, the load can be switched without interruption in the service using the optional Vertiv™ Liebert® MBC.

### 7.1 Touchscreen Control Panel

The Touchscreen Control Panel of EXM is active whenever the UPS has input power. The touchscreen LCD on the front of the UPS permits:

- Logging in to the system.
- Customizing the user interface.
- Checking the status of the UPS and its external batteries, including all the measured parameters, events and alarms.
- Determining when the users logged in and out.
- Silencing the alarms.
- Turning the UPS On and Off.
- Resetting faults.
- Enabling the Energy Saving Mode.



- Scan the QR code at right to obtain a copy of the Touchscreen Control Panel Manual.

## 7.2 Access Level Log In

The Touchscreen Control Panel provides security by limiting the authority to change how the UPS operates. Each of the four access levels offers different authority:

- **Observer** - Viewing permission only, can choose graphic or text display, view logs and silence alarms; no PIN required
- **Operator** - Permission to start and shut down the UPS, edit the display layout, test the battery, reset faults, enable or disable Eco Mode operation, enable equalize battery charging and acknowledge alarms; PIN required
- **Administrator**- All functions of Operator plus permission to change PIN's for Operator and Administrator level, configure the Status Gauge, set energy saving mode and change network communication protocols; PIN required
- **Service**- All functions of Administrator plus permission to alter system configuration and change Service PIN; PIN required.

## 7.3 Default PIN Numbers

Vertiv Services sets PIN's when setting up the UPS. These default PIN's may be changed by those with Administrator or Service access (See [Access Level Log In](#) above ) Default PINs are:

**Operator:** 1234

**Administrator:** 2345

### NOTICE

Risk of unauthorized changes to operational settings. It can cause damage to the equipment. The default PIN numbers should be changed immediately to prevent unauthorized personnel from changing UPS operation or even shutting down the UPS. Refer to the **Vertiv™ Liebert® Touchscreen Control Panel User Manual (SL-26200)** for details available at Vertiv's website: [www.vertiv.com](http://www.vertiv.com).

## 7.4 Vertiv™ Liebert® EXM Operating Modes

The UPS is designed to operate as an online, double conversion, reverse transfer system in the following modes:

- Load on Inverter Mode
- Load on Battery Mode
- Auto Restart Mode
- Eco Mode
- Load on Bypass Mode
- Module Redundancy Mode
- Frequency Converter Mode
- Power Conditioner Mode
- Maintenance Mode (Manual Bypass)
- Sleep Mode
- Paralleling Mode
- Output Voltage Adjustment
- Generator Mode

**NOTE:** The user controls and indicators referred to in these procedures are detailed in the Vertiv™ Liebert® Touchscreen Control Panel User Manual (SL-26200), available at Vertiv's website: [www.vertiv.com](http://www.vertiv.com).

**NOTE:** The audible alarm may sound at various points during these procedures. It can be canceled at any time by pressing the menu button (under any login), pressing Alarms and then pressing Alarms.

**NOTE:** This unit refers to some modes and conditions that are set or adjusted using proprietary service software. To take advantage of all available features for the Vertiv™ EXM, the unit must be commissioned by a Vertiv authorized engineer.

### Load on Inverter Mode

Operating in the Load on Inverter Mode, the Liebert® EXM rectifier derives power from a utility AC source and supplies the regulated DC power to the inverter, which regenerates precise AC power to supply the connected equipment. The rectifier also uses the utility source power to charge the batteries.

### Module Redundancy Mode

When the EXM is in Module Redundancy Mode, the load percentage is calculated using the available power module capacity or nameplate rating capacity, whichever is lower.

Module Redundancy Mode can be set at the factory or by the user. A maximum of one module can be set for redundancy. Availability of this feature depends on setting module capacity of the frame. Refer to the **UPS Control Manual (SL-26200)**, for instructions on setting this feature. The manual is available at Vertiv Web site: [www.vertiv.com](http://www.vertiv.com)

#### Example 1

- Ten 20 kVA power modules installed.
- Nameplate rating capacity = 180 kVA
- One power module in redundant mode.
- Configured capacity = 180 kVA
- Load = 180 kVA

The load percentage will be calculated based on the nameplate rating capacity (180 kVA capacity). In the event of a single power module fault, the system will signal a Loss of Redundancy Alarm and a Power Hardware Mismatch and continue in double conversion mode and provide up to 180 kVA capacity.

#### Example 2

- Ten 20 kVA power modules installed.
- Nameplate rating capacity = 200 kVA
- One power module in redundant mode.
- Configured capacity = 180 kVA
- Load = 180 kVA

The load percentage will be calculated based on the available power module capacity (200 kVA capacity). In the event of a single power module fault, the system will signal a Loss of Redundancy Alarm and a Power Hardware Mismatch Alarm. The system will continue in double conversion mode and provide up to 180 kVA capacity.

#### Example 3

- Ten 20 kVA power modules installed.
- Nameplate rating capacity = 200 kVA
- One power module in redundant mode.

- Configured capacity = 180 kVA
- Load = 190 kVA

The load percentage will be calculated based on the available power module capacity (200 kVA capacity). The system will signal a Loss of Redundancy Alarm. The system will continue in double conversion mode and provide up to 200 kVA capacity.

### Frequency Converter Mode

When the Vertiv™ Liebert® EXM is set to Frequency Converter Mode permits configuring the unit for 50 Hz output, bypass is disabled and the battery is optional to support load. This mode can only be enabled at the factory or by the Vertiv Services.

### Power Conditioner Mode

When the EXM is set to Power Conditioner Mode, the battery is disabled in this mode. This mode can only be enabled at the factory or by the Vertiv Services.

### Load on Battery Mode—Requires Optional External Battery Cabinet

When utility AC power fails, the EXM protects the critical load by instantaneously channeling battery power from the optional External Battery Cabinets to the inverter, which continues supporting the critical load without interruption. When the utility power returns and is within the acceptable limits, the Liebert® automatically shifts back to the Load on Inverter Mode, with the rectifier powering the critical load.

### Auto Restart Mode

The battery may become exhausted following an extended AC utility failure. The inverter shuts down when the battery reaches the End of Discharge voltage (EOD). The UPS may be programmed to “Auto Recovery after EOD” after a delay time, if the AC utility recovers. This mode and any delay time may be programmed by the commissioning engineer.

### Load on Bypass Mode

When the EXM is in the Load on Bypass Mode, the load is directly supported by the utility power and is without the battery backup protection.

The static transfer switch of EXM will shift the load from the inverter to the Load on Bypass Mode without interruption in the AC power if the inverter is synchronous with the bypass and any of the following occurs:

- Inverter fails.
- Inverter overload capacity is exceeded.
- Inverter is manually turned off by the user.

**NOTE: If the inverter is asynchronous with the bypass, the static switch will transfer the load from the inverter to the bypass WITH interruption in the AC power to the critical load. This interruption will be less than 15 ms (in 50 Hz) or less than 13.33 ms (in 60 Hz). This interruption time may be altered by modifying the Output transfer interrupt time setting.**

### Eco Mode (Single Module UPS System Only)

When Eco mode is selected, the EXM switches inverter power from the UPS input to the bypass input to save energy by improving UPS efficiency. In this mode, the bypass is the preferred source. If the bypass voltage or frequency becomes outside preset limits, the UPS load is transferred back to the inverter.

## Maintenance Mode (Manual Bypass)

For maintenance or repair, the EXM may be operated in maintenance mode. To place the EXM in maintenance mode, follow the instructions in [Switching the UPS from Normal Operation to Maintenance Bypass](#) on the next page.



**WARNING! Risk of arc flash and electric shock. It can cause damage to the equipment, injury and death. The UPS input and the output must be protected with external overcurrent protection devices. In maintenance mode, the input and the output busbars remain energized and present an electric shock hazard.**

Risque d'arc ou de décharge électrique pouvant entraîner des dommages matériels, des blessures et même la mort. L'entrée et la sortie du système ASC doivent être protégées par des dispositifs de protection de surintensité externes. En mode d'entretien, les barres omnibus d'entrée et de sortie demeurent sous tension et présentent un risque de décharge électrique.

## Output Voltage Adjustment

This feature allows a Liebert Customer Engineer to adjust the output voltage of the Vertiv™ Liebert® EXM over a range of 5% to +5% of nominal. The output voltage adjustment can be used to compensate for any drop in line voltage that may occur when the UPS is at a significant distance from the protected load. In addition, it can be used to optimize the UPS output voltage for the loads that operate more efficiently at a voltage different from the nominal output voltage of the EXM.

## Generator Mode

The Liebert® EXM UPS can be set up for operation in Generator Mode by a Vertiv Service engineer. The setup requires connecting Pins J26:2 to J26:4. The battery charger is disabled in the Generator Mode.

## 7.5 UPS Startup

The Liebert® UPS must be fully installed and commissioned before the startup, and the external power isolators must be closed. Once those general conditions are met, the UPS may be started.



**WARNING! Risk of electrical shock and arc flash. It can cause damage to the property, injury and death. During this procedure the output terminals will become live. If any load equipment is connected to the UPS output terminals, check with the load user and ascertain whether it is safe to apply power to the load. If the load is not ready to receive the power, then ensure that it is safely isolated from the UPS output terminals.**

Risque d'arc ou de décharge électrique pouvant entraîner des dommages matériels, des blessures et même la mort. Durant cette procédure, les bornes de sortie seront sous tension. Si un équipement chargé est raccordé aux bornes de sortie du système ASC, veuillez vous informer auprès de l'utilisateur de la charge s'il est sécuritaire d'appliquer une alimentation à la charge. Si la charge n'est pas prête à recevoir une alimentation, alors assurez-vous qu'elle est isolée sécuritairement des bornes de sortie du système ASC.

### NOTICE

Risk of improper startup when feeding a downstream transformer. It can damage the connected equipment. If the UPS is supplying a downstream transformer not provided by Liebert, the UPS should be put on maintenance bypass to energize it to mitigate the risk of in-rush current

### 7.5.1 Startup Procedure

**To start the UPS from a fully powered down condition:**

1. Log in as Operator, Administrator, or Service.
2. Ensure that the Liebert Power Module Assembly ready switches are latched (in down position).

3. Close the external input circuit breaker and connect input power. The touchscreen activates.
4. The rectifier goes through its startup sequence and the bypass static switch is activated.
5. Close the external output circuit breaker.
6. Touch the *Operat* tab.
7. Touch the *Inverter On* button. When asked to confirm, touch the *Inverter On* button again.

The power module run lights will start flashing green while the unit goes through the inverter startup sequence. After about a minute, the inverter will turn on, the static bypass will open and the power module run lights will be solid green.

8. Close the battery breaker.

## 7.5.2 Startup in Eco Mode

Eco Mode is available only on a single module Vertiv™ Liebert® EXM UPS.

1. Log in as Operator, Administrator, or Service.
2. Touch the *Operat* tab.
3. Touch *Energy Saving Mode Activation Setup*.
4. In the drop-down menu, touch *Enable*.
5. Touch *Save*.

The UPS should now be in static bypass mode with the inverter on standby. The status bar at the top of the screen will say ENERGY SAVING MODE ACTIVE.

## 7.5.3 Switching Between UPS Operation Modes

**To switch from the Load on Inverter Mode to the Static Bypass Mode:**

1. Log in as Operator, Administrator, or Service.
2. Touch the *Operate* tab.
3. Touch the *Inverter Off* button to switch to the Load on Bypass Mode.
4. To continue, confirm turning off the inverter when prompted.

### NOTICE

Risk of power loss to connected load. It can cause damage to the equipment. The load equipment is not protected from supply aberrations, such as spikes, sags and failures, when the EXM is operating with the Load on Bypass.

**To switch from the Load on Bypass Mode to the Load on Inverter Mode:**

1. Log in as Operator, Administrator, or Service.
2. Touch the *Operate* tab.
3. Touch *Inverter On* button.

To continue, confirm turning On the inverter when prompted.

## 7.6 Switching the UPS from Normal Operation to Maintenance Bypass

Follow the procedure below to transfer the load from the UPS inverter output to the Maintenance Bypass system.

## NOTICE

Risk of loss of power to the connected load. It can damage to the equipment. This procedure must be performed by properly trained and qualified personnel who are knowledgeable about the operation of this system. Failure to follow these instructions will result in loss of power and possible damage to critical equipment. Before performing this operation, read any messages on the touchscreen to be sure that bypass supply is regular and the inverter is synchronous with it. If those conditions are not present, there is a risk of a short interruption in powering the load.

**This procedure assumes that the UPS is operating normally.**

1. Log in as Operator, Administrator, or Service.
2. Touch the Operate tab.
3. Touch the *Inverter Off* button.
4. To continue, confirm turning off the inverter when prompted.

**NOTE: Pressing Silence from the Operate tab cancels the audible alarm, but leaves the warning message displayed until the appropriate condition is rectified.**

5. Open the Vertiv™ Liebert® EXM *MBC door* to gain access to the bypass isolation breaker (BIB), the maintenance bypass breaker (MBB) and the maintenance isolation breaker (MIB).
6. When the lamp indicator on the MBC is illuminated, press and hold the adjacent *Push* button and remove the *Key* from the lock (KO).
7. Insert the *Key* into the lock on the MBB and turn the *Key*.
8. Close the MBB.
9. Verify the MBB is closed. Failure to close the MBB will interrupt power to the load.
10. Open the MIB.
11. Remove the *Key* from the lock on the MIB. Insert the *Key* into the lock (KO) and turn the *Key*.
12. The UPS system is now isolated from the critical load.
13. For a single-input system, the BIB remains closed; this allows power to remain present at the UPS input; refer to **Figure 7.2** on page 57
14. For a single-source, dual-input system, the BIB can be opened to further isolate the UPS from input power; refer to **Figure 7.2** on page 57



**WARNING! Risk of electrical shock and arc flash. It can cause damage to the property, injury and death. Wait 5 minutes for the internal DC busbar capacitors to discharge before attempting to remove the internal protective barriers.**

Risque d'arc ou de décharge électrique pouvant entraîner des dommages matériels, des blessures et même la mort. Attendez 5 minutes que les condensateurs de barre omnibus c.c. internes se déchargent avant d'essayer de retirer les barrières de protection internes.



**WARNING! Risk of electrical shock and arc flash. It can cause damage to the property, injury and death. Even with the UPS in maintenance bypass and off, portions of the Liebert® EXM system are still energized. Service must be performed by properly trained and qualified personnel only.**

Risque d'arc ou de décharge électrique pouvant entraîner des dommages matériels, des blessures et même la mort. Même lorsque le système ASC est en mode de dérivation d'entretien et hors tension, des parties du système EXM de Liebert demeurent sous tension. L'entretien ne doit être confié qu'à un personnel qualifié et dûment formé.

**NOTICE**

Risk of power loss to connected load. It can cause damage to the equipment. The load equipment is not protected from normal supply aberrations when the Liebert® EXM UPS is operating in the maintenance bypass mode.

**Figure 7.1 One line diagram, Single Input UPS with 3 Breaker Maintenance Bypass Cabinet and Panelboard**

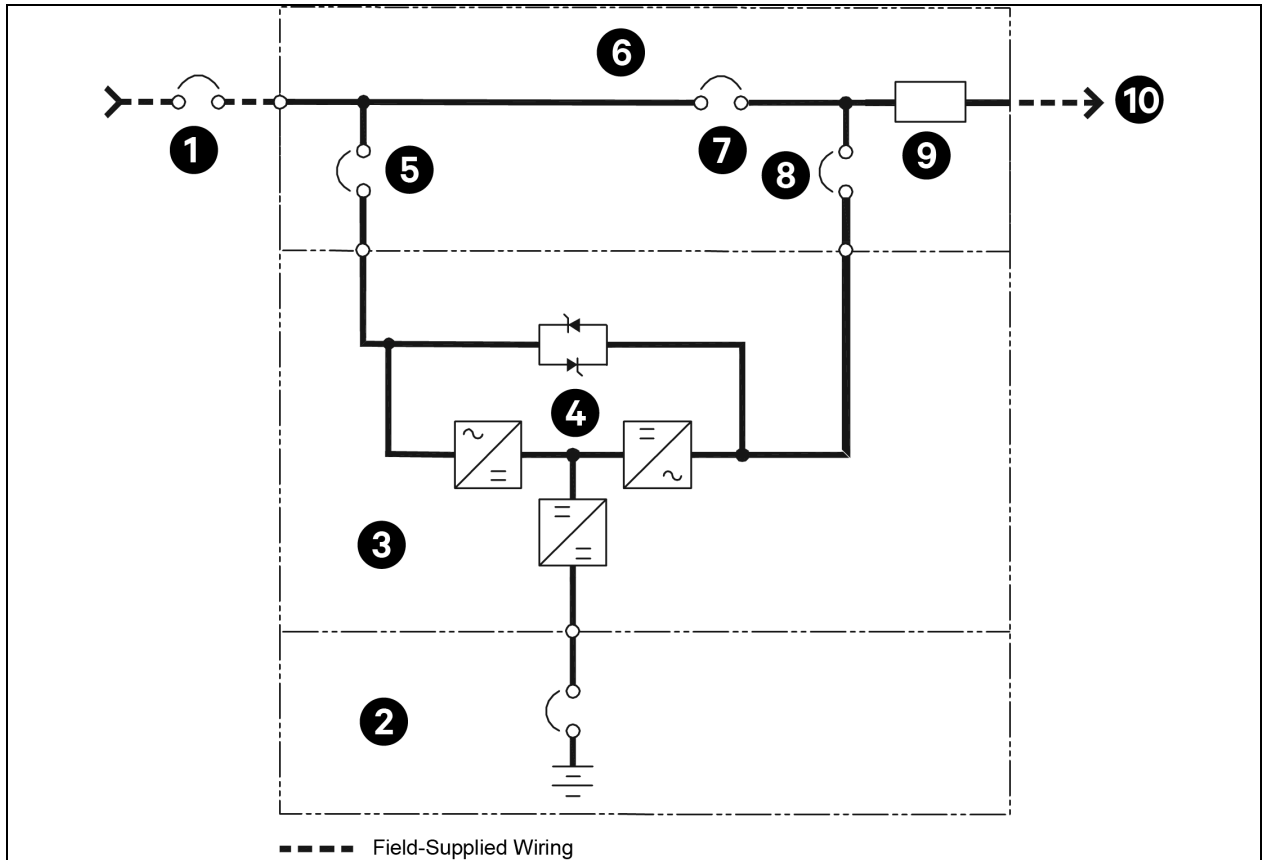

**Notes to Figure**

1. Install in accordance with the national and the local electrical codes.
2. The input and the bypass must share the same single source.
3. A neutral is required from the system AC input source. Vertiv recommends a full capacity neutral and grounding conductors.
4. The bypass and the rectifier input and output cables must be run in the separate conduits.
5. The control wiring must be run in the separate conduits.

Item	Description	Item	Description
1	* Bypass AC input 4-wire + GND	6	MBC - Maintenance Bypass Cabinet
2	Battery	7	MBB - Maintenance Bypass Breake
3	UPS cabinet	8	MIB - Maintenance Isolation Breaker

Item	Description	Item	Description
4	Static bypass	9	Output busbar
5	BIB - Bypass Isolation Breaker	10	AC output 208 V 4-wire + GND
* External overcurrent protection by others			

## 7.7 Switching the UPS from Maintenance Bypass to Normal Operation

Follow the procedure below to transfer the load from the Maintenance Bypass system to the UPS inverter output.

These conditions must be met for this operation to proceed:

- The UPS must be operating normally.
- The BIB breaker must be closed.
- The UPS system must be in the Maintenance Bypass mode of operation.

### NOTICE

Risk of loss of power to the connected load. It can damage to the equipment. This procedure must be performed by properly trained and qualified personnel who are knowledgeable about the operation of this system. Failure to follow these instructions will result in loss of power and possible damage to critical equipment. Before performing this operation, read any messages on the touchscreen to be sure that bypass supply is regular and the inverter is synchronous with it. If those conditions are not present, there is a risk of a short interruption in powering the load.

1. Verify that the Vertiv™ Liebert® EXM UPS is in Load on Bypass Mode.

**NOTE: Pressing the Alarm Silence Switch cancels the audible alarm, but leaves the warning message displayed until the appropriate condition is rectified.**

2. Open the *Vertiv™ Liebert® MBC Door* to gain access to the BIB, MBB and the Maintenance Isolation Breaker (MIB).
3. When the Lamp indicator on the MBC is illuminated, press and hold the adjacent *Push* button and remove the key from the lock (KO).
4. Insert the *Key* into the lock on the MIB, and turn the *Key*.
5. Close the MIB.
6. Verify the MIB is closed. Failure to close the MIB will interrupt power to the load.
7. Open MBB.
8. Remove the *Key* from the lock on the MBB.
9. Insert the *Key* into the lock (KO) and turn the key.
10. The UPS system is now supplying power to the critical load.
11. Log in as Operator, Administrator, or Service.
12. Touch the *Operatetab*.
13. Touch the *Inverter On* button.
14. To continue, turn on the inverter when prompted.

## 7.8 De-Energize Liebert® EXM with Maintenance Bypass Cabinet

### NOTICE

Risk of loss of power to the connected load. It can cause damage to the equipment. This procedure must be performed by properly trained and qualified personnel who are knowledgeable about the operation of this system. This procedure will remove power from the critical bus. Take precautions by providing a backup power supply or shutting down equipment before de energizing the EXM.

#### To de-energize the system:

1. Log in as Operator, Administrator, or Service.
2. Touch the *Operate* tab.
3. Touch the *Inverter Off* button.
4. To continue, turn Off the inverter when prompted.
5. Open all battery circuit breakers including the internal battery breaker, if applicable.
6. If the MBC is a Vertiv cabinet, open the MIB. If the MBC is a customer-issued switchgear or a non Vertiv cabinet, open the breakers that supply power to the critical bus.
7. Open the rectifier input circuit breaker and the bypass input breaker, if dual input. If the MBC is a customer-issued switchgear or a non Vertiv cabinet, open the breakers that supply power to the UPS input and bypass input, if dual input.
8. Allow 5 minutes for all the DC circuits and capacitors to fully discharge.
9. Open the external feeder breaker to the MBC or the bypass switchgear.
10. Install a lockout/tagout on the external feeder breaker to the MBC or the bypass switchgear.
11. Use a digital multimeter to verify there is no AC or DC voltage present at the UPS input, output, and bypass busbars.
12. Use a digital multimeter to verify there is no AC or DC voltage present at the MBC, BIB, MIB and MBB, breakers.

## 7.9 De-Energize Vertiv™ Liebert® EXM Without Maintenance Bypass Cabinet

### NOTICE

Risk of loss of power to the connected load. It can cause damage to the equipment. This procedure must be performed by properly trained and qualified personnel who are knowledgeable about the operation of this system. This procedure will remove power from the critical bus. Take precautions by providing a backup power supply or shutting down equipment before de energizing the EXM.

#### To de-energize the EXM:

1. Log in as Operator, Administrator, or Service.
2. Touch the *Operate* tab.
3. Touch the *Inverter Off* button.
4. To continue, turn off the inverter when prompted.
5. Open all battery circuit breakers, including the internal battery breaker, if applicable.
6. Open the UPS output circuit breakers.
7. Open the UPS input circuit breaker and the bypass circuit breaker, dual input systems only.
8. Allow 5 minutes for all the DC circuits and capacitors to fully discharge.

- Use a digital multimeter to verify there is no AC or DC voltage present at the UPS input, output, and bypass busbars.

**Figure 7.2 Typical Configuration for Single UPS**

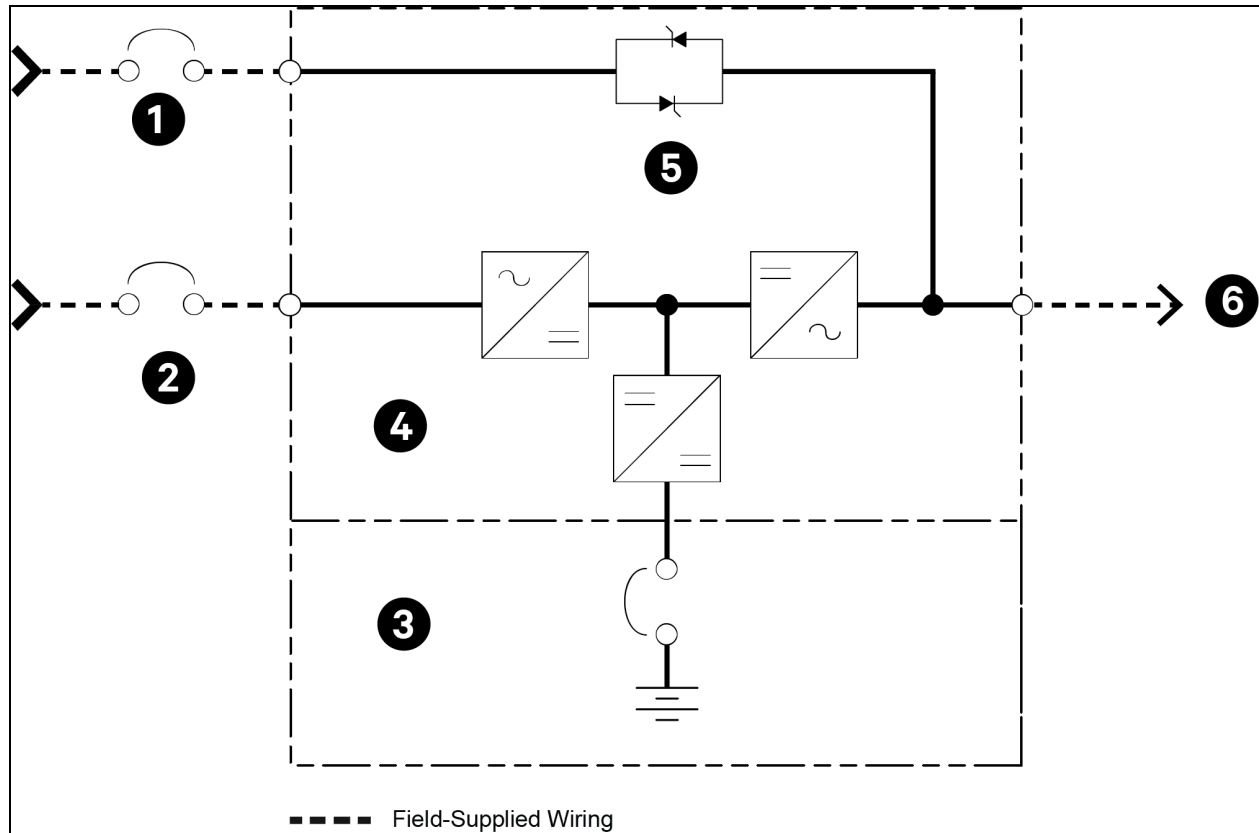

**Notes to Figure:**

- Install in accordance with the national and the local electrical codes.
- The input and the bypass must share the same single source.
- A neutral is required from the system AC input source. Vertiv recommends a full capacity neutral conductor and grounding conductors.
- The bypass and the rectifier inputs and output cables must be run in separate the conduits.
- Control wiring must be run in the separate conduits.
- Customer must supply shunt trip breakers with 120 V coils to the bypass and rectifier inputs.

Item	Description	Item	Description
1	Bypass AC input 4-Wire + GND (See note 6)	4	UPS
2	Rectifier AC input 4-Wire + GND (See note 6)	5	Static bypass
3	Battery	6	AC output 208 V 4-wire + GND

\* External overcurrent protection by others.

## 7.10 Parallel Operations—Determine Control Panel Firmware

Parallel operation differs depending on the software in the control menu. To determine which version is installed on the UPS, activate the touchscreen menu, touch the Context Menu and touch About.

If the firmware is V1.1, perform the appropriate steps in [Parallel Operations - Software Version 1.1](#) below

## 7.11 Parallel Operations - Software Version 1.1

### 7.11.1 De-Energize a Vertiv™ Liebert® EXM Parallel System Software Version 1.1

To shut down a UPS parallel system using V1.1 controller software:

1. Log in as Operator, Administrator, or Service.
2. Verify that the system and the connected load are prepared for shutdown.
3. Touch the *Operate* tab.
4. Touch *the Inverter Off button*. A pop-up window opens and states that the system is operating in a multi-module system and asks whether to control one inverter or the entire system.
5. Touch *System*. The power module run lights will start flashing yellow while the unit goes through the inverter shutdown sequence. After a few seconds, the inverter will turn Off, the static bypass will close and the power module run lights will be Off. All UPS units in the system will go to bypass.
6. Check the parallel switchgear.

#### NOTICE

Risk of loss of power to the connected load. Can cause equipment damage. The following procedure will remove power from the critical bus. Before beginning these steps, shut down the connected load or transfer the connected load to an input power supply not dependent on the Liebert® EXM UPS system that is being de-energized.

- a. If the parallel switchgear is a matching Vertiv cabinet, open the MIB.
  - b. Open all the MOB.
7. Open the input breaker for each UPS and the breaker feeding the MBB in the parallel switch gear.

The system is now de-energized, and its output power supply is off.

### 7.11.2 Re-Energize a EXM Parallel System Software Version 1.1

To restart EXM parallel system from a fully powered-down condition using V1.1 controller software:

1. Log in as Operator, Administrator, or Service.
2. Close the input breakers for all UPSs.
3. The LCD on each UPS will turn On, the *LCD* icons will begin flashing green, and the rectifier will start. The *bypass* and *output* icons will illuminate green. The battery LED will illuminate red.
4. Close the MOB circuit breaker to each UPS.
5. Close the MIB circuit breaker.



**WARNING! Risk of electric shock. It can cause damage to the equipment, injury and death. The following procedure will supply power to the critical bus. Before beginning, notify all personnel that the input power is being supplied to the circuits. Verify that the connected load is prepared for input current.**

6. Touch the *Operate* tab
7. Touch the Inverter On button. A pop up window states that the system is operating in a multi module system and asks whether to start one inverter or the entire system.
8. Touch System. The LCD icons will start flashing green while the unit goes through the inverter startup sequence. After about a minute, the inverter will turn on, the static bypass will open and the icons will be solid green.
9. Close all battery breakers.

## 7.12 Emergency Shutdown with EPO

This circuit has been designed to switch off the UPS in emergency conditions such as fire or flood. The system will turn off the rectifier, inverter and stop powering the load immediately (including the inverter and bypass), and the battery stops charging or discharging.

If the input utility is present, the UPSs controls will remain active; however, the output will be turned off. To remove all power from the UPS, the external feeder breaker should be opened.

## 7.13 Auto Restart

When the main and the bypass sources fail, the UPS draws power from the battery system to supply the load until the batteries are depleted. When the UPS reaches its end of discharge (EOD) threshold, it will shut down.

The UPS will automatically restart and enable the output power:

- After utility power is restored.
- If Auto Recovery after EOD Enabling is enabled in the UPS configuration. (This is set by factory or by Vertiv Services).
- After the Auto Recovery after EOD Delay Time expires. The default delay is 10 minutes.

During the auto recovery delay, the Vertiv™ Liebert® EXM will be charging its batteries to provide a safety margin for equipment shutdown if input power fails again.

If the Auto Recovery after EOD Enabling feature is disabled, the system must be restarted manually.

## 7.14 Reset After Shutdown for Emergency Stop (EPO Action) or Other Conditions

Once all appropriate measures have been taken to correct the problem indicated by the alarm message appearing on the carry out this procedure to restore the UPS to regular operation following an EPO action or for the following reasons:

- Inverter Overtemperature
- Cut Off Overload
- Battery Overvoltage
- Excessive switching (BYP: XFER COUNT BLOCK)

When the user confirms that the fault is cleared:

1. Log in as Operator, Administrator, or Service.
2. Touch the *Operate* tab.
3. Touch the yellow *Reset* button to clear the Emergency Power Off state.
4. Press the Inverter *On* button on the right side of the Operator Control Panel for longer than 2 seconds (after the rectifier has qualified).

**NOTE: The rectifier will start automatically 5 minutes after the overtemperature fault is cleared.**

After the EPO button is pressed, if the input utility is removed, the UPS will shut down completely. When input utility is restored, the EPO condition will clear and the UPS will enable the static bypass and restore the output.

## 7.15 Battery Protection

### 7.15.1 Battery Undervoltage Warning

Before the end of discharge, the Vertiv™ Liebert® EXM displays a low battery warning. After low-battery warning, the battery has the capacity for 5 minutes discharging with full load (default time). The Liebert® EXM can be user-configured to display this warning from 3 to 60 minutes before end of discharge.

### 7.15.2 Battery End of Discharge (EOD) Protection

If the battery voltage is lower than the end-of-discharge voltage, the battery converter will be shut down. Refer to **Table 8.8** on page 66 .

## 7.16 Operation



**WARNING! Risk of electrical shock and arc flash. It can cause damage to the property, injury and death. The Liebert® EXM contains high voltages internally. Components that can only be accessed by opening the protective cover with tools cannot be serviced or replaced by the user. Only properly trained and qualified service personnel are authorized to remove the protective covers.**

Risque d'arc ou de décharge électrique pouvant entraîner des dommages matériels, des blessures et même la mort. L'armoire Liebert® EXM contient des tensions élevées à l'interne. L'utilisateur ne peut ni entretenir ni remplacer des composants accessibles uniquement en ouvrant le couvercle de protection avec des outils. Seul du personnel de service qualifié et dûment formé est autorisé à retirer les couvercles de protection.

The EXM operates in the modes shown in **Table 7.1** below . This section describes various kinds of operating procedures under each operating mode, including transfer between the operating modes, UPS setting and the procedures for turning On/Off inverter.

**Table 7.1 UPS Operating Modes**

Operating Mode		Descriptions
Load on Inverter	NORMAL	UPS powers the load
Load on Bypass	BYPASS	The load power supply is provided by the static bypass. This mode can be regarded as a temporary transition mode between the Load on Inverter Mode and Maintenance Bypass Mode, or a temporary abnormal operating status.
Maintenance Mode	MAINT	UPS shuts down, the load is connects to the mains through the Vertiv™ Liebert® MBC. In this mode the load is not protected against abnormal input utility power.



**Notes to Figure:**

1. Install in accordance with the national and the local electrical codes.
2. The input and the bypass must share the same single source.
3. A neutral is required from the system AC input source. Vertiv recommends a full-capacity neutral conductor and grounding conductors.
4. The bypass and the rectifier inputs and output cables must be run in the separate conduits.
5. The control wiring must be run in the separate conduits.
6. Customer must supply shunt trip breakers with 120 V coils to the bypass and rectifier inputs.

Item	Description	Item	Description
1	Bypass AC input 4-wire + GND (See note 6 )	4	UPS
2	Rectifier AC input 4-wire + GND (See note 6 )	5	Static bypass
3	Battery	6	AC output 208 V 4-wire + GND
* External overcurrent protection by others.			

## 8 Specification and Technical Data

### 8.1 Conformity and Standards

The Vertiv™ Liebert® EXM UPS has been designed to conform to the following standards:

Parameter	Specification
Safety	UL 1778, 5th Edition, CSA 22.2 107.3-14
Surge	IEC 61000-4-5 Criteria B
Harmonics	IEC 61000-3-4
Electrical fast transient	IEC 61000-4-4, Criteria B
ESD	IEC 61000-4-2, Criteria B
FCC	Part 15, Class A
Radiated immunity	IEC 61000-4-3, Criteria A
Conducted immunity	IEC 61000-4-6, Criteria A
Low-frequency signals	IEC 61000-2-2 Criteria A
Transportation	ISTA Procedure 1H
ISO	9001
Misc	OSHA, ASME, NEMA PE-1

The EXM has UL and c-UL approval.

#### 8.1.1 ENERGY STAR Certification

The Liebert® EXM UPS is ENERGY STAR certified satisfying ENERGY STAR Program Requirements Product Specification for Uninterruptible Power Supplies (UPSs) - Eligibility Criteria, Version 2.0.

### 8.2 UPS Environmental Requirements

The EXM UPS is designed to operate under the following environmental conditions without damage or degradation in electrical operating characteristics:

**Table 8.1 Environmental Requirements**

Item	Requirements
Acoustical noise, dBA, at 55 in. (1.4 m)	60
Operating altitude	4922 ft (1500 m) above mean sea level. (1% maximum kW derate per 100 m rise between 4922 and 9800 ft (1500-3000 m).
Relative humidity	95%
Operating temperature, °F (°C)	104 (40)
UPS storage/transport temperature, °F (°C)	-4 to 158 (-20 to 70)

**Table 8.2 UPS Mechanical Characteristics**

Rated Power, kVA	20 - 140	160-200
Dimensions	34-2/3 x 39-3/8 x 78-3/4	46-1/4 x 39-3/8 x 78-3/4
W x D x H, in (mm)	(880 x 1000 x 2000)	(1175 x 1000 x 2000)
Weights	See Table 1 for weights	
Color	RAL 7021 (Black)	
Protection degree IEC (60529)	IP20	

## 8.3 UPS Electrical Characteristics

Refer to additional circuit breaker notes in [Accessory Fuses and Back Feed Breaker Wiring](#) on page 24 .

**NOTE: The breakers and cables used must be in accordance with the NEC ANSI/NFPA 70. A disconnect breaker must be provided for the AC input, the DC input and the AC output. Recommended cable sizes are suitable for operation at a maximum temperature of 104 °F (40 °C).**

**Table 8.3 UPS Currents and Terminals - Input, Single-input unit, 208 V Operation**

Unit Rating	Nominal Input Current	Maximum Input Current	OCP Device Rating	Bolt Size	75 °C Wire Current, Total	Copper Wire	Aluminum Wire
20	59	68	90	M10	115	(1) #2	(1) 1/0
40	119	136	175	M10	230	(1) 4/0	(2) 1/0
60	178	205	300	M10	400	(2) 3/0	(2) 4/0
80	237	273	350	M10	460	(2) 4/0	(2) 300 kcmil
100	297	341	450	M10	610	(2) 350	(2) 400 kcmil
120	356	409	600	M10	760	(2) 500	(3) 350
140	415	478	600	M10	760	(2) 500	(3) 350
160	475	546	700	M10	930	(3) 350	(3) 500
180	534	614	800	M10	1140	(3) 500	(4) 400
200	594	682	1000	M10	1240	(4) 350	(4) 500

Wire sized for operation at 40 °C.

**Table 8.4 UPS Currents and Terminals - Input, Dual - input Unit, 208 V Operation**

Unit Rating	Nominal Input Current	Maximum Input Current	OCP Device Rating	Bolt Size	75 °C Wire Current, Total	Copper Wire	Aluminum Wire
20	59	68	90	M10	115	(1) #2	(1) 1/0
40	119	136	175	M10	230	(1) 4/0	(2) 1/0
60	178	205	300	M10	400	(2) 3/0	(2) 4/0
80	237	273	350	M10	460	(2) 4/0	(2) 300 kcmil

**Table 8.4 UPS Currents and Terminals - Input, Dual - input Unit, 208 V Operation (continued)**

Unit Rating	Nominal Input Current	Maximum Input Current	OCP Device Rating	Bolt Size	75 °C Wire Current, Total	Copper Wire	Aluminum Wire
100	297	341	450	M10	610	(2) 350	(2) 400 kcmil
120	356	409	600	M10	760	(2) 500	(3) 350
140	415	478	600	M10	760	(2) 500	(3) 350
160	475	546	700	M10	930	(3) 350	(3) 500
180	534	614	800	M10	1140	(3) 500	(4) 400
200	594	682	1000	M10	1240	(4) 350	(4) 500

Wire sized for operation at 40 °C.

**Table 8.5 UPS Currents and Terminals - Bypass, Dual-input Unit, 208 V Operation**

Unit Rating	Nominal Input Current	OCP Device Rating	Bolt Size	75 °C Wire Current, Total	Copper Wire	Aluminum Wire
20	56	70	M10	115	(1) #2	(1) #2
40	111	150	M10	175	(1) 3/0	(1) 4/0
60	167	225	M10	285	(1) 300	(2) 2/0
80	222	300	M10	400	(2) 3/0	(2) 4/0
100	278	350	M10	460	(2) 4/0	(2) 300 kcmil
120	333	450	M10	620	(2) 350	(2) 500
140	389	500	M10	620	(2) 350	(2) 500
160	444	600	M10	760	(2) 500	(3) 350
180	500	700	M10	930	(3) 350	(3) 500
200	555	700	M10	930	(3) 350	(3) 500

Wire sized for operation at 40 °C.

**Table 8.6 UPS Currents and Terminals - Output**

Unit Rating	Nominal Input Current	OCP Device Rating	Bolt Size	75 °C Wire Current, Total	Copper Wire	Aluminum Wire
20	56	70	M10	115	(1) #2	(1) #2
40	111	150	M10	175	(1) 3/0	(1) 4/0
60	167	225	M10	285	(1) 300	(2) 2/0
80	222	300	M10	400	(2) 3/0	(2) 4/0
100	278	350	M10	460	(2) 4/0	(2) 300 kcmil
120	333	450	M10	620	(2) 350	(2) 500

**Table 8.6 UPS Currents and Terminals - Output (continued)**

Unit Rating	Nominal Input Current	OCP Device Rating	Bolt Size	75 °C Wire Current, Total	Copper Wire	Aluminum Wire
140	389	500	M10	620	(2) 350	(2) 500
160	444	600	M10	760	(2) 500	(3) 350
180	500	700	M10	930	(3) 350	(3) 500
200	555	700	M10	930	(3) 350	(3) 500

Wire sized for operation at 40 °C.

**Table 8.7 Rectifier Input**

Parameter	20-200 kVA	
	50/60 Hz, 3-Phase, 4-wire plus ground	
Rated AC voltage	208/120 V	220/127 V
Input voltage range, startup/operating	177-253 VAC	187-264 VAC
Input voltage rRange, operating *	125-253 VAC	132-264 VAC
Frequency	50 or 60 Hz (40-70 Hz Range)	
Power factor	0.99 Full Load, 0.98 Half Load	
THD	5% Full Load	

\* Derated operation for reduced input voltage: 208 V Operation (125-177 VAC), 220 V operation (132-187 VAC).

**Table 8.8 Battery DC Intermediate Circuit**

Parameter	20-200 kVA
Battery bus voltage	288
Number of lead-acid cells	144 = (24 x 6 cell [12 V] blocks), nominal
Float voltage	2.25 V/cell, selectable from 2.2 - 2.3 V/cell
Temperature compensation	-3.0 mV/°C, selectable from 0 to -5.0 mV/°C around 77 °F (25 °C) or 86 °F (30 °C) or inhibit
Ripple voltage	≤1%
Ripple current	≤5%
Boost charge voltage	2.35 V/cell (selectable from 2.30-2.40V/cell)
Boost control	Float-boost current trigger 0.050 C10; selectable 0.030-0.070 Boost-float current trigger 0.010 C10; selectable 0.005-0.025 24 hour safety time-out; selectable 8-30 hr Boost charge mode inhibit; selectable

**Table 8.8 Battery DC Intermediate Circuit (continued)**

Parameter	20-200 kVA
End of discharge	1.63 V/cell for lower EOD timer. (10-45 minutes, 15 default) 1.75 V/cell for upper EOD timer. (46-180 minutes, 60 default)
Battery charge operation	Constant current and constant voltage charge mode Programmable auto trigger or inhibit of boost mode
Battery charging power maximum current	UPS, kVA: 20, 40, 60, 80, 100, 120, 140, 160, 180, 200 Battery charging power, kW: 3, 6, 9, 12, 15, 18, 21, 24, 27, 30 Maximum charging current, A: 9, 18, 27, 36, 45, 54, 63, 72, 81, 90

**Table 8.9 Inverter Output to Critical Load**

Parameter	20-200 kVA
Rated AC voltage	208/120 V or 220/127 V, 50/60 Hz, 3-Phase, 4-Wire Plus Ground
Frequency	50/60
Overload capacity	105% - 110% of full load for 60 minutes at 104 °F (40 °C) ambient 110% - 125% of full load for 10 minutes at 104 °F (40 °C) ambient 125% - 150% of full load for 60 seconds at 104 °F (40 °C) ambient >150% of full load for a minimum of 200 milliseconds at 104 °F (40 °C) ambient
Fault current	Short circuit for 200 ms
Non-linear load capability	100%
Neutral current capability	170%
Steady state voltage stability	±1% (balanced load)
Voltage regulation	±1% for balanced load ±5% for 100% unbalanced load
Phase balance	120° ±1° for balanced load 120° ±15°± for 100 unbalanced load
<b>Transient Voltage Response</b>	
THD	<1.5% (0-100% linear load) <4% (0-100% non-linear load)
Sync frequency range	Rated frequency ± 2 Hz (selectable ± 0.5 to ± 3 Hz)
Frequency slew rate	0.1-3 Hz
Frequency regulation	Less than ±0.25%1.5
Voltage adjustment range	±5%

**Table 8.10 Bypass Input**

Parameter	20-200 kVA
Rated AC voltage	208/120 V or 220/127 V, 50/60 Hz, 3-Phase, 4-wire plus ground
Overload	150% load, long term
Upstream protection, bypass line	Thermomagnetic circuit-breaker, rated up to 125% of nominal output current
Current rating of neutral cable, A	1.7*I <sub>n</sub>
Frequency, Hz	50 or 60
Transfer time between bypass and inverter, ms	Uninterrupted transfer: <1 ms Interrupted transfer: <20 ms (40,60,80,100, can be selected)
Bypass voltage tolerance, %VAC	Upper Limit: +10, +15 or +20, default +15 Lower Limit: -10, -20, -30 or -40; default: -20 (Delay to Accept Steady Bypass Voltage: 10 sec)
Bypass frequency tolerance, %	± 10% or ± 20%; default: ± 20%
Synchronization window	± 0.5, 1,2,3 Hz Default value: ±2 Hz

**Table 8.11 AC/AC Efficiency, Loss and Air Exchange**

AC/AC Efficiency	Data									
Load on inverter (dual conversion), %	95.5% Max									
Inverter efficiency (DC/AC) (Battery at nominal voltage 288 VDC and full-rated linear load)										
Rated power, kVA	20-200									
Load on battery, %	94.8% Max									
Heat losses and air exchange										
Rated power, kVA	20	40	60	80	100	120	140	160	180	200
Load on inverter, kW	0.9	1.8	2.7	3.6	4.5	6.6	7.7	8.8	9.9	11
No load, kW	0.3	0.6	0.9	1.2	1.5	1.8	2.1	2.4	2.7	3
Maximum forced air cooling (Front intake, rear exhaust), CFM (m <sup>3</sup> /hr)	32 (115)	64 (231)	96 (346)	128 (462)	160 (575)	407 (691)	475 (806)	542 (922)	610 (1037)	678 (1152)
Heat dissipation, BTU/Hr (kW)	3843 (1.13)	7610 (2.23)	11,278 (3.30)	14,977 (4.39)	18,645 (5.46)	21,193 (6.21)	23,512 (6.89)	29,529 (8.65)	31,994 (9.37)	35,548 (10.42)

**Table 8.12 Recommended Lug Sizes (Compression Type) M10, 3/8 in Bolt**

<b>Cable Size</b>	<b>T&amp;B Copper Two-Hole</b>	<b>T&amp;B Aluminum Two-Hole</b>
#6 AWG	256-030695-868	—
#4 AWG	256-030695-733	—
#2-3 AWG	54811BE	—
#1 AWG	54857BE	—
#1/0 AWG	256-30695-593	—
#2/0 AWG	54862BE	60238
#3/0 AWG	54864BE	60244
#4/0 AWG	54866BE	60250
250 kcmil	54868BE	60256
300 kcmil	54870BE	60262
350 kcmil	54872BE	60267
400 kcmil	54874BE	60269
500 kcmil	54876BE	60273
600 kcmil	54878BE	60275
700 kcmil	54879BE	60277
750 kcmil	54880BE	60278

This page intentionally left blank

## 9 Maintenance

### 9.1 Safety Precautions

Observe the safety precautions in [Important Safety Instructions](#) on page 1.

Only properly trained and qualified personnel should perform maintenance on the UPS system.

Observe all of the warnings and cautions below before performing any maintenance on the UPS system and associated equipment. Also observe the manufacturer's safety precautions pertaining to the battery, along with the battery safety precautions in this document.



**WARNING! Risk of electrical shock and arc flash. It can cause damage to the property, injury and death. Only Vertiv or Vertiv trained service personnel should work on this equipment. Both AC and DC high voltages are present in lethal amounts within this equipment. Extreme care should be taken when working around UPS equipment. Always identify the source of connecting wiring prior to disconnecting. Mark any disconnected wires, so they can be properly reconnected. Do not substitute parts except as authorized by Vertiv. Maintain the UPS cabinets free of foreign materials such as solder, wire cuttings, etc. Call Vertiv Services if you are not sure of the procedures to follow or if you are not familiar with the design or operation of the equipment.**

Risque d'arc ou de décharge électrique pouvant entraîner des dommages matériels, des blessures et même la mort. L'entretien et la réparation de cet équipement doivent être confiés exclusivement à un personnel qualifié de Vertiv ou formé par Vertiv. Des hautes tensions c.a. et c.c. mortelles sont présentes dans cet équipement. Faites preuve d'une grande prudence lorsque vous travaillez à proximité d'un système ASC. Identifiez toujours la source d'un câble de raccordement avant de le débrancher. Identifiez les câbles déconnectés afin de pouvoir les reconnecter correctement. Ne remplacez aucun composant sans l'autorisation expresse de Vertiv. Assurez-vous que les armoires d'ASC sont exemptes de matériaux étrangers tels que des résidus de soudure, des bouts de câble, etc. Communiquez avec Vertiv Services si vous doutez de la procédure à suivre ou si la conception ou le fonctionnement de l'équipement ne vous sont pas familiers.



**WARNING! Risk of electrical shock and arc flash. It can cause damage to the property, injury and death. Extreme caution is required when performing the maintenance. Be constantly aware that the UPS system contains high DC as well as AC voltages. With the input power Off and the optional battery cabinet disconnected, high voltage at filter capacitors and power circuits should be discharged within 30 seconds. However, if a power circuit failure has occurred, you should assume that high voltage still exists after shutdown. Check with a voltmeter before making contact. AC voltage will remain on the bypass and output contactors and the static bypass switch, unless the associated external circuit breakers are opened. Check for voltage with both AC and DC voltmeters before making contact. When the UPS system is under power, both the operator and any test equipment must be isolated from direct contact with earth ground and the UPS chassis frame by using rubber mats. Some components within the cabinets are not connected to chassis ground. Any contact between floating circuits and the chassis is a lethal shock hazard. Use differential oscilloscopes when measuring a floating circuit. The differential input should have at least 800 vrms common mode input rating and a common mode rejection ratio of at least 80 dB. Exercise caution that the test instrument exterior does not make contact either physically or electrically with earth ground. In case of fire involving electrical equipment, use only carbon dioxide fire extinguishers, or others approved for use in electrical fire fighting.**

Risque d'arc ou de décharge électrique pouvant entraîner des dommages matériels, des blessures et même la mort. Les opérations d'entretien requièrent une extrême prudence. Soyez toujours conscient du fait que le système ASC contient des tensions c.c. et c.a. élevées. Une fois l'alimentation d'entrée et du boîtier facultatif de batteries coupées, la haute tension aux condensateurs de filtrage et aux circuits d'alimentation devrait se dissiper en moins de 30 secondes. En cas de défaillance d'un circuit d'alimentation, toutefois, il importe de présumer qu'une tension élevée est présente même après l'arrêt. Vérifiez toujours les tensions avec un voltmètre avant d'établir des contacts. Les contacteurs de dérivation et de sortie, de même que le commutateur statique de dérivation, continueront d'afficher une tension c.a. à moins que les disjoncteurs externes associés ne soient ouverts. Vérifiez les tensions avec des voltmètres c.a. et c.c. avant d'établir tout contact. Lorsque le système ASC est sous tension, les responsables de l'entretien et l'équipement d'essai doivent reposer sur des tapis de caoutchouc pour prévenir tout contact direct avec le sol et avec le châssis du système lors des interventions. Certains composants à l'intérieur des armoires ne sont pas connectés à la masse du châssis. Tout contact entre les circuits flottants et le châssis présente un risque de décharge mortelle. Utilisez des oscilloscopes différentiels lors des mesures d'un circuit flottant. L'entrée différentielle devrait être d'au moins 800 Vrms en mode commun et avoir un taux de réjection de mode commun d'au moins 80 dB. Il importe de veiller à ce que l'extérieur des équipements d'essai n'entre pas en contact physique ou électrique avec le sol. En cas d'incendie associé à du matériel électrique, n'utilisez que des extincteurs à dioxyde de carbone ou homologués pour la lutte contre les incendies d'origine électrique.

## 9.2 Limited Life Components

The Vertiv™ Liebert® EXM UPS has a design life well in excess of 10 years. Well maintained units can continue to provide economic benefits for 20 years or more. Long life components are used in the UPS wherever practical and cost effective. However, due to the currently available component material, manufacturing technology limitations and the general function and use of the component, a few components in your EXM UPS will have a shorter life cycle and require replacement in less than 10 years.

The following components utilized in your UPS system have a limited life cycle and are specifically exempt from warranty. To prevent a wear out failure of one of these components affecting your critical load operations, Vertiv recommends these components be periodically inspected and replaced before the expected expiration of their life cycle. The expected life of each component listed below is simply an estimate and is not a guarantee. Individual users may have site specific requirements, maintenance and other environmental conditions that affect the length of the component's useful life cycle.

**Table 9.1 Component Service Life**

Component	Expected Life	Replace in:
Air filters	5 years	Check four times per year
Power modules & static bypass assembly	20 years	18 years
Frame fans	10 years	8 years

**NOTE: Component expected life requires ambient temperature conditions <77 °F (<25 °C). If temperature conditions are higher, expected life will be shorter.**

In most cases, replacement components must exactly match the original component specifications. These replacement components are not readily available from third party component distributors. For assistance with your specific component specifications, replacement component selection and sourcing, call 1-800-Liebert. For customers using Vertiv Services preventive maintenance periodic inspection of these components is part of this service, as well as recommending component replacement intervals to customers to avoid unanticipated interruptions in critical load operations.

## 9.3 Routine Maintenance

Become thoroughly familiar with the equipment, but at no time go beyond the specific procedures in this manual while performing maintenance or correcting a malfunction. If you have any doubt as to what must be done, call Vertiv Services at 800-543-2378 for further instructions. The UPS is designed for unattended operation, but does require some common sense maintenance.

- Keep good records, troubleshooting is easier if you maintain historical service records.
- Keep the UPS free of dust and any moisture.
- Keep the UPS cool:
  - Battery systems must be kept in the range of 72 °F-77 °F (22 °C-25 °C) in order to meet design specifications for capacity and longevity.
  - The UPS will reliably meet all the performance specifications at temperatures up to 104 °F (40 °C), and can be slightly derated for operation at even higher temperatures. However, the performance and longevity will be optimized when the UPS is operated at the same temperature as the batteries.
- Keep connections tight.
- Tighten all connections at installation and at least annually thereafter. (See [Torque Requirements](#) on page 75 ).

### 9.3.1 Record Log

Set up a maintenance log to record the scheduled checks and any abnormal conditions.

The log should have space for all the metered data including phase readings, alarm messages, UPS mode of operation, air filter replacement date and observation notes. A second log should be maintained for the battery module as directed by the battery manufacturer.

Vertiv recommends a periodic walk through inspection of the UPS and battery rooms to check for visible and audible indications of problems. Log the inspection, metered parameter indications and any discrepancies.

### 9.3.2 Air Filters

The air filters must be inspected and serviced on a regular schedule. The period between inspections will depend upon the environmental conditions. Under normal conditions, the air filters will require cleaning or replacement approximately every two months.

All Vertiv™ Liebert® EXM UPS models have replaceable filter elements behind the grille in the front of the unit. This element can be changed with the UPS operating by opening the outer door. The air filters of the Liebert® EXM are washable and reusable. One set of air filters is shipped with each Liebert® EXM.

Abnormal or dusty conditions will require more frequent cleaning and replacement of air filters. Inspect installations in new buildings more often, then extend the inspection period as experience dictates.

#### Replacing Air Filters

Installing the two air filter sizes in a Liebert® EXM requires only a Phillips screwdriver. Each filter is held in place by a bracket on either side of each filter. Refer to [Air Filters](#) above for details about filter maintenance.

##### To replace a filter:

1. Open the UPS front door and locate the filters on the back side of the front door see **Figure 9.1** on the next page .
2. Remove one bracket and loosen the screw on the second bracket. The second bracket need not be removed.
3. Remove the dust filter to be replaced.

4. Insert the clean filter.
5. Reinstall the bracket, tightening the screw securely.
6. Tighten the screw on the second bracket.

Figure 9.1 Air Filter Replacement

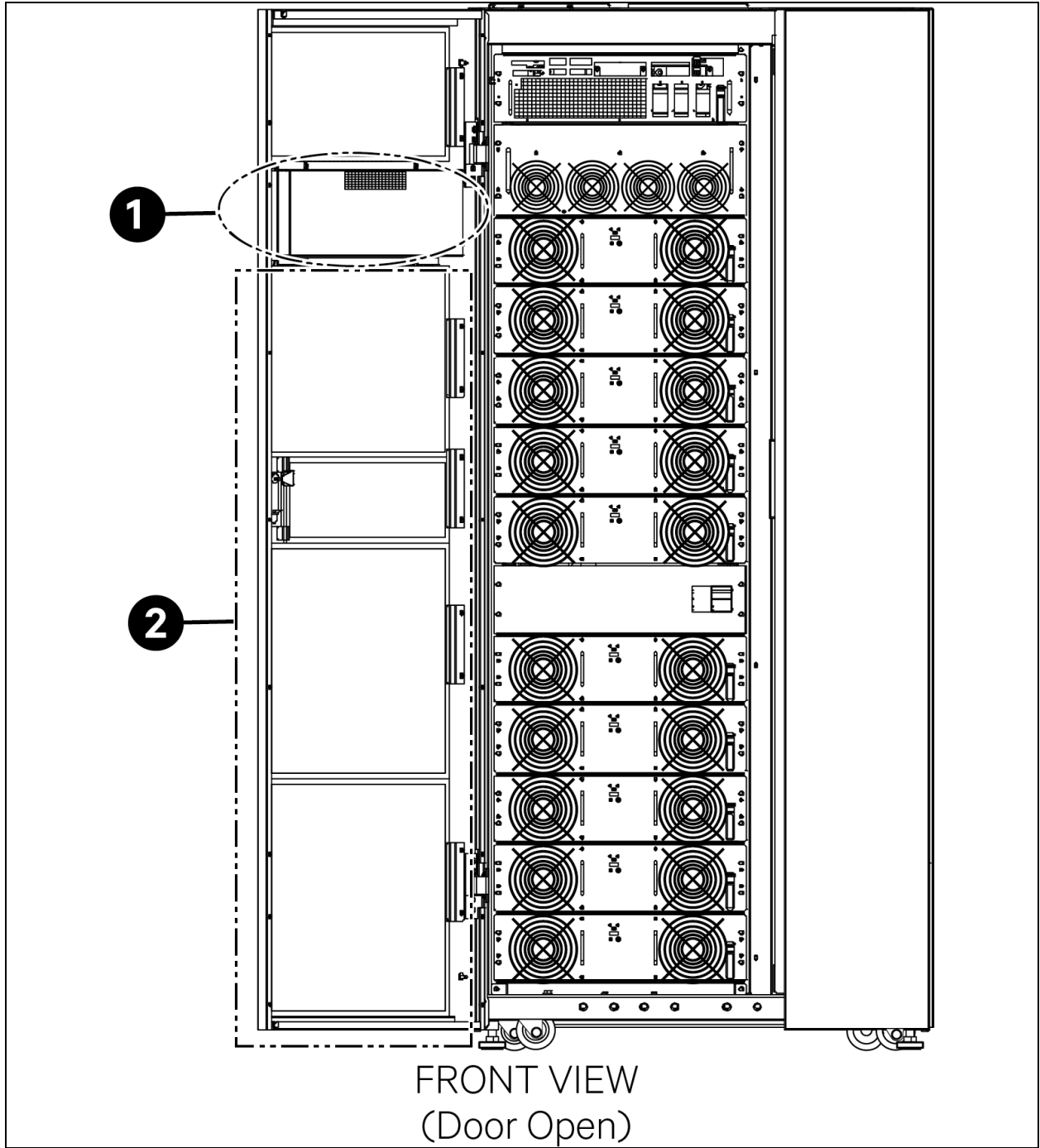

Item	Description
1	Control panel
2	Replaceable air filter

### 9.3.3 Torque Requirements

All electrical connections must be tight.

Table 9.2 below and Table 9.3 below provide the torque values for the connections in the UPS and batteries. Use these values unless the equipment is labeled otherwise.

**Table 9.2 Busbars (for Power Wiring)**

Bolt Shaft Size	Lb-in (Nm)
3/8 in. (M10)	240 (27)

**Table 9.3 Terminal Block with Compression Lugs (for Control Wiring)**

AWG Wire Size or Range	Lb-in (Nm)
#22 - #14	3.5 to 5.3 (0.4 to 0.6)

## 9.4 Detecting Trouble

It is important that the operator check the instrument readings if abnormal equipment performance is suspected. Any metered value that differs appreciably from normal could mean an impending malfunction, and should be investigated.

Items to check on the various UPS display screens include:

- The output voltage of all the phases should be within 2% of the normal voltage. Output currents on each phase should not normally differ by more than 20%. If a greater difference is noted, the load is unbalanced and corrective action should be taken to redistribute the load, if possible.
- If the UPS has not operated on battery power during the last 10 hours, the batteries should require little charging current. Battery mimic should indicate normal DC voltage with relatively little battery charge current.
- The input current on each phase should be within 10% of the average input current. The alarm messages indicate malfunction or impending malfunction. A daily check of the Operator Control Panel will help to provide an early detection of problems. Refer to **Appendix B:** on page 79 to interpret alarm messages.
- Tracing a problem to a particular section is facilitated by alarm messages and the metered parameter indications. These are stored in the Status Reports and can be displayed at the Operator Control Panel or at an optional terminal.

**NOTE: If the UPS system has a blown fuse, the cause should be determined before you replace the fuse. Contact Vertiv Services at 800-543-2378.**

## 9.5 Reporting a Problem

If a problem occurs within the UPS, review all alarm messages along with other pertinent data. This information should be given to the Liebert® UPS Service dispatcher. Call Vertiv Services at 800-543-2378 to report a problem or to request assistance.

## 9.6 Corrective Actions

Recommended corrective actions for each alarm message on the Operator Control Panel and the Remote Alarm Status Panel may be found in **Appendix B:** on page 79 .

## 9.7 Recommended Test Equipment

**Table 9.4** below lists recommended test equipment and tools required to maintain, troubleshoot and repair the UPS module. Instruments of equivalent range and accuracy may be substituted. All instruments should be calibrated and be within the current calibration cycle. Calibration data for the instruments should be maintained in equipment history files and the instruments labeled for audit and verification.

**Table 9.4 Recommended Test Equipment and Tools**

Qty	Test Equipment	Manufacturer	Model or Type
1	Oscilloscope	Tektronix, H-P or fluke	DC to 50 MHz
2	Voltage probes	Tektronix, H-P or fluke	10X, with 10 ft cable
2	Voltage probes	Tektronix, H-P or fluke	100X, with 10 ft cable
1	Digital multi-meter	Fluke	8060, with test leads
1	Tool kit	N/A	Standard electrical contractor tools.

# Appendices

## Appendix A: Hazardous Substances or Elements Announcement

Table 10.1 Hazardous Substances or Elements

Part Name	Lead (Pb)	Mercury (Hg)	Cadmium (Cd)	Chrome (Cr6+)	Polybrominated Biphenyl (PBB)	Polybrominated Diphenyl Ethers (PBDE)
	Hazardous Substances					
Hex copper stud	X	✓	✓	✓	✓	✓
PCBA	X	✓	✓	✓	✓	✓
AC Capacitor	X	✓	✓	✓	✓	✓
DC Capacitor	X	✓	✓	✓	✓	✓
Fan	X	✓	✓	✓	✓	✓
Cables	X	✓	✓	✓	✓	✓
LCD	X	✓	✓	✓	✓	✓
Sensors	X	✓	✓	✓	✓	✓
Large-medium power magnetic components	X	✓	✓	✓	✓	✓
Circuit breaker / rotating switch	X	✓	✓	✓	✓	✓
Semiconductors	X	✓	✓	✓	✓	✓
Battery (when applicable)	X	✓	✓	✓	✓	✓
Insulation monitoring device (when applicable)	X	✓	✓	✓	✓	X
<p>✓ - Means the content of the hazardous substances in all the average quality materials of the part is within the limits specified in SJ/T-11363-2006</p> <p>X - Means the content of the hazardous substances in at least one of the average quality materials of the part is outside the limits specified in SJ/T11363-2006</p>						
<p>Vertiv has been committed to the design and manufacturing of environment-friendly products. It will reduce and eventually eliminate the hazardous substances in the products through unremitting efforts in research. However, limited by the current technical level, the following parts still contain hazardous substances due to the lack of reliable substitute or mature solution:</p> <ol style="list-style-type: none"> <li>1. All solders in the products contain lead.</li> <li>2. Copper alloy contains lead.</li> <li>3. Back-light bulb contains mercury.</li> <li>4. The ceramic materials of the ceramic capacitor, the copper terminals and copper leads of metallic film capacity contain lead.</li> <li>5. The glass of resistor contains lead.</li> </ol>						

**Table 10.1 Hazardous Substances or Elements (continued)**

Part Name	Lead (Pb)	Mercury (Hg)	Cadmium (Cd)	Chrome (Cr6+)	Polybrominated Biphenyl (PBB)	Polybrominated Diphenyl Ethers (PBDE)
Hazardous Substances						
6. The glass of LCD contains lead, and the back-light lamp contains mercury. 7. The lead in the battery is determined by the battery feature and technical levels. 8. The insulation monitoring device contains lead and PBDE.						
<b>About Environment Protection Period:</b> The Environment Protection Period of the product is marked on the product. Under normal working conditions and normal use of the products observing relevant safety precautions, the hazardous substances in the product will not seriously affect the environment, human safety or property in the Environment Protection Period starting from the manufacturing date.						
<b>About the battery:</b> The battery life is dependent on the ambient temperature and charging / discharging times. The battery life will be shortened if the battery is used under high temperature or in deep discharging status. Refer to the manufacturer’s product literature for details.						

## Appendix B: UPS Status Messages

**Table 10.2** below shows all event messages as they appear in the current status area of the LCD or the history log, along with a description and recommended actions, if any.

**Table 10.2 UPS Status Messages**

Event Message	Description / Suggested Action (if any)
Comm. Fail	The CAN communication between internal monitor and rectifier/inverter/bypass fails. Contact Vertiv Services at 800-543-2378 for assistance.
Battery Overtemp	The battery temperature is over the limit. Check the battery temperature and ventilation.
Ambient Overtemp	The Ambient temperature is over limit. Check the ventilation of UPS room.
Replace Battery	Battery should be replaced. Contact Vertiv Services at 800-543-2378 for assistance.
Battery Low Pre-warning	Before the end of discharging, battery undervoltage pre-warning should occur. After this pre-warning, battery should have the capacity for 3 minutes discharging with full load. The time is user configured from 3 to 60 minutes. Shut down the load in time.
Battery End of Discharge	Inverter turned Off due to low battery voltage. Check the utility failure and try to fix it.
Mains Volt. Abnormal	Mains Voltage exceeds the upper or lower limit and results in rectifier shutdown. Check the input line-to-neutral voltage amplitude of rectifier.
Mains Undervoltage	Mains Voltage is undervoltage (120 V~132 V). Check the input line-to-line voltage amplitude of rectifier.
Mains Freq. Abnormal	Mains frequency is out of limit range and results in rectifier shutdown. Check the rectifier's input voltage frequency.
Rectifier Fault	Rectifier Fault; Contact Vertiv Services at 800-543-2378 for assistance.
Rectifier Overtemp	The temperature of heat sink is too high to keep the rectifier running. The UPS can recover automatically. Check the environment and ventilation.
Charger Fault	The Charger has failed. Contact Vertiv Services at 800-543-2378 for assistance.
Input Fuse Fail	Input fuse is open. Contact Vertiv Services at 800-543-2378 for assistance.
Control Power 1 Fail	Control Power 1 has failed or has been lost. Contact Vertiv Services at 800-543-2378 for assistance.
Mains Phase Reversed	Input phase sequence is reversed. Contact Vertiv Services at 800-543-2378 for assistance.
Soft Start Fail	Rectifier could not start due to low DC bus voltage. Contact Vertiv Services at 800-543-2378 for assistance.
Bypass Unable to Trace	This alarm is triggered by an inverter software routine when the amplitude or frequency of bypass voltage is beyond the normal range.  The amplitude threshold is fixed for positive and negative 10% rating.  This alarm automatically resets once the bypass voltage goes normal.  First verify that the bypass voltage and frequency displayed on the panel is within the selected range. Note here the rated voltage and frequency are specified by "Output voltage level" and "Output frequency level" respectively.  If the displayed voltage is believed to be abnormal, then verify the bypass voltage and frequency presented to the UPS. Check the external supply if it is found to be faulty.  Contact Vertiv Services at 800-543-2378 for assistance.

**Table 10.2 UPS Status Messages (continued)**

Event Message	Description / Suggested Action (if any)
Bypass Abnormal	<p>This alarm is triggered by an inverter software routine when the amplitude or frequency of bypass voltage exceeds the limit.</p> <p>This alarm automatically resets once the bypass voltage goes normal.</p> <p>First, check whether there are relevant alarms, such as “Bypass disconnect open,” “Bypass phase reverse” and “Mains neutral lost.” If they appear, solve them first.</p> <p>Then verify that the bypass voltage and frequency displayed on the panel is within the bypass limit. Note here the rated voltage and frequency are specified by “Output voltage level” and “Output frequency level” respectively.</p> <p>If the displayed voltage is believed to be abnormal, then verify the bypass voltage and frequency presented to the UPS. Check the external bypass supply if it is found to be faulty. If the utility is likely to trigger this alarm frequently, the bypass limit can be changed a little larger through the configuration software according to the customer’s agreement.</p> <p>Contact Vertiv Services at 800-543-2378 for assistance.</p>
Inverter Asynchronous	<p>This alarm is triggered by an inverter software routine when the inverter and bypass waveforms are misaligned by more than 6 degrees in phase. This alarm resets automatically once the condition is no longer true.</p> <p>First check if the alarm “Bypass unable to trace” or “Bypass abnormal” occurs. If so, solve it first.</p> <p>Verify the waveform of the bypass voltage. If it is too distorted, ask the customer to verify and seek any possible measurements.</p> <p>Contact Vertiv Services at 800-543-2378 for assistance.</p>
Inverter Fault	<p>This alarm indicates a fault condition exists within the inverter.</p> <p>Contact Vertiv Services at 800-543-2378 for assistance.</p>
Fan Fault	<p>At least one of the cooling fans failed. Contact Vertiv Services at 800-543-2378 for assistance.</p>
Inverter STS (relay) Fail	<p>At least one of the static switches of inverter side is open or short circuit. This fault is locked until power Off. Contact Vertiv Services for assistance at 800-543-2378 for assistance.</p>
Bypass STS Fail	<p>At least one of the static switches of bypass side is open or short circuit. This fault is locked until power Off. Contact Vertiv Services at 800-543-2378 for assistance.</p>
Output Fuse Fail	<p>At least one of the output fuses is open. Contact Vertiv Services at 800-543-2378 for assistance.</p>
Control Power 2 Fail	<p>Control Power 2 is abnormal or lost. Contact Vertiv Services at 800-543-2378 for assistance.</p>
Unit Overload	<p>The UPS is confirmed to be overload when the load arises above 105% nominal rating.</p> <p>The alarm automatically resets once the overload condition is removed.</p> <p>Confirm that the alarm is true by checking the load percentage indicated on the LCD to determine which phase is being overloaded.</p> <p>If the alarm is true, measure the actual output current to verify that the indications are valid. Disconnect unnecessary load and ensure the safety. In a parallel system, a severe load sharing error can also leads to the alarm.</p> <p>Contact Vertiv Services at 800-543-2378 for assistance.</p>
System Overload	<p>The UPS parallel system is confirmed to overload when the total load arises above 105% nominal rating for the set basic number of UPSs. The alarm automatically resets once the overload condition is removed.</p> <p>Confirm that the alarm is true by checking the system load percentage indicated on the LCD to determine which phase is being overloaded.</p> <p>If the alarm is true, measure the actual output current to verify that the indications are valid. Disconnect unnecessary load and ensure the safety. In a parallel system, a severe load sharing error can also leads to the alarm.</p>
Unit Overload Timeout	<p>The UPS is confirmed to overload and the overload times out.</p>

Table 10.2 UPS Status Messages (continued)

Event Message	Description / Suggested Action (if any)
	<p><b>NOTE:</b></p> <p>The highest loaded phase will indicate overload timing-out first.</p> <p>When the timer is active, then alarm "unit overload" should also be active as the load is above nominal.</p> <p>When the timer has expired, the inverter Static Switch is opened and the load transferred to bypass. The inverter shutdown and will restart after 10 seconds.</p> <p>If the load decreases lower than 95% after 5 minutes, the system will transfer back to inverter mode.</p> <p>Confirm that the alarm is genuine by checking the load percentage indicated on the LCD. If an overload is indicated then check the load, and investigate any additional load connected prior to the alarm (if applicable).</p>
Bypass Phase Reversed	<p>The phase sequence direction of bypass voltage is reversed.</p> <p>Normally, the phase of Phase B lags 120 degrees behind Phase A, and the phase of Phase C lags 120 degrees behind Phase B.</p> <p>Verify that the phase rotation of the bypass supply presented to the UPS is correct, and rectify it if it is found to be in error. Contact Vertiv Services at 800-543-2378 for assistance.</p>
Load Impact Transfer	A transfer to bypass occurred due to a large step load. The UPS should recover automatically. Turn On connected equipment in sequential order to reduce the step loading of the inverter.
Transfer Timeout	<p>The load is on bypass power due to excessive number of transfers that occurred within the last hour.</p> <p>The UPS will recover automatically and will transfer the load back to inverter power within an hour.</p>
Load Sharing Fault	UPS working within a parallel system are not sharing load current correctly. Contact Vertiv Services at 800-543-2378 for assistance.
DC Bus Abnormal	<p>Shut Off inverter due to abnormal DC bus voltage.</p> <p>Contact Vertiv Services at 800-543-2378 for assistance.</p>
System Transfer	The whole paralleled UPS system transferred to bypass at the same time. This message will appear on the UPS which passive transfer to bypass.
DC Bus Overvoltage	<p>Rectifier, inverter and battery converter were shutdown because DC bus voltage is too high.</p> <p>Check whether there is a fault in rectifier side. If not, then check whether overload occurs.</p> <p>Restart the inverter after resetting the fault. If the fault does not clear, contact Vertiv Services at 800-543-2378 for assistance.</p>
LBS Active	The LBS setting is active. The UPS is acting as an LBS leader/follower in a dual bus configuration.
Battery ground fault	Battery ground fault from dry contact signal. Contact Vertiv Services at 800-543-2378 for assistance.
Inverter turned On manually	Manual Turn On using front panel
Inverter turned Off manually	Manual Turn Off using front panel.
EPO	Emergency Power Off.
Transfer Confirm	Interrupted Transfer Confirm.
Transfer Cancel	Interrupted Transfer is cancel
Unit Off Confirm	Unit Turned Off Confirm.
System Off Confirm	System Turned Off Confirm.
Fault Reset	Fault Reset.

**Table 10.2 UPS Status Messages (continued)**

Event Message	Description / Suggested Action (if any)
Alarm Silence	Alarm Silence.
Turn On Fail	Turn On Fail.
Alarm Reset	Audible Alarm Reset.
Load on Bypass	UPS in Load on Bypass Mode.
Load on Inverter	UPS in Load on Inverter Mode.
Load on Battery	UPS in Load on Battery Mode.
Output Disabled	UPS Output Disabled.
Maint. Disconnect Closed	Maintenance Disconnect Closed.
Reserved	—
Output Disconnect Open	Output Disconnect Open.
Battery Reverse	Connect the battery again and check the wiring of batteries.
No Battery	Check the battery and the wiring of batteries.
Auto start	After UPS was shutdown at EOD, inverter auto starts when utility is restored.
BCB closed	BCB closed from dry contact signal.
BCB open	BCB open from dry contact signal.
Battery Float Charging	Battery is float charging.
Battery Boost Charging	Battery is boost charging.
Battery Discharging	Battery is discharging.
Battery Period Testing	Battery is period self-testing.
Batt. Capacity Testing	Battery is capacity self-testing.
Batt. Maint. Testing	Battery is maintenance self-testing.
Inverter in Setting	Inverter is in parameter setting.
Rectifier in Setting	Rectifier is in parameter setting.
Batt. Converter Fault	Battery converter output voltage beyond limits or battery fuse failed. Battery converter shuts down. Battery backup not available.
Operation Invalid	This record is registered following an incorrect operation.
Byp. Abnormal Shutdown	Both bypass and inverter voltages unavailable. Load interruption.
Mains Neutral Lost	AC Input mains reference neutral not detected.
Battery Room Alarm	Environment in battery room needs attention.
Rec Flash Update	Rectifier firmware is being updated.
Inv Flash Update	Inverter firmware is being updated.
Monitor Flash Update	Monitor firmware is being updated.
LBS abnormal	LBS is abnormal.



---

©2023 Vertiv Group Corp. All rights reserved. Vertiv™ and the Vertiv logo are trademarks or registered trademarks of Vertiv Group Corp. All other names and logos referred to are trade names, trademarks or registered trademarks of their respective owners. While every precaution has been taken to ensure accuracy and completeness here, Vertiv Group Corp. assumes no responsibility, and disclaims all liability, for damages resulting from use of this information or for any errors or omissions.