



Vertiv™ Liebert® ITA2 1-3 kVA

User Manual

The information contained in this document is subject to change without notice and may not be suitable for all applications. While every precaution has been taken to ensure the accuracy and completeness of this document, Vertiv assumes no responsibility and disclaims all liability for damages resulting from use of this information or for any errors or omissions. Refer to other local practices or building codes as applicable for the correct methods, tools, and materials to be used in performing procedures not specifically described in this document.

The products covered by this instruction manual are manufactured and/or sold by Vertiv. This document is the property of Vertiv and contains confidential and proprietary information owned by Vertiv. Any copying, use or disclosure of it without the written permission of Vertiv is strictly prohibited.

Names of companies and products are trademarks or registered trademarks of the respective companies. Any questions regarding usage of trademark names should be directed to the original manufacturer.

Technical Support Site

If you encounter any installation or operational issues with your product, check the pertinent section of this manual to see if the issue can be resolved by following outlined procedures.

TABLE OF CONTENTS

1 Important Safety Instructions	1
2 Special Declaration	3
3 Product Introduction	9
3.1 Product Features	9
3.2 Model Configurations	10
3.3 Product Appearance and Components	10
3.3.1 Product Appearance	10
3.3.2 Product Components	11
3.4 Operating Principal	14
3.5 UPS State and Operation Mode	15
3.5.1 Normal Mode	16
3.5.2 Bypass Mode	17
3.5.3 Battery Mode	18
3.5.4 ECO Mode (for UPS Equipped with Battery only)	19
3.5.5 Fault State	19
4 UPS Installation	21
4.1 Unpacking and Inspection	22
4.2 UPS Moving	22
4.3 Installation Preparation	23
4.3.1 Location	23
4.3.2 Environmental Requirement	23
4.3.3 Installation Tools	26
4.4 External Protective Devices	28
4.4.1 Overcurrent	28
4.4.2 Earth Leakage Current	28
4.4.3 Battery Input	29
4.5 Mechanical Installation	29
4.5.1 Tower Installation	29
4.5.2 Rack Installation	32
4.6 Connecting Power Cables	38
4.6.1 Connecting Input Plug and Load	38
4.6.2 Connecting Battery Cables	39
5 UPS Operation Instructions	43

5.1 UPS Start-Up	44
5.2 Initial Start-up Guidance	45
5.3 Transfer Procedures Between Operation Modes	48
5.3.1 Transfer from Normal Mode to Battery Mode	48
5.3.2 Transfer from Inverter Mode to Bypass Mode	48
5.3.3 Transfer from Bypass Mode to Inverter Mode	50
5.4 UPS Complete Shutdown	52
5.5 REPO	52
5.6 Auto Restart	52
5.7 Language Selection	53
5.8 Changing Current Date and Time	55
5.9 Setting Password	57
6 Operation and Display Panel	61
6.1 Introduction	61
6.1.1 LED Indicators	63
6.1.2 Audible Alarm (Buzzer)	63
6.1.3 LCD and Functional Keys	64
6.2 LCD Menu Structure	66
6.3 LCD Screen Types	66
6.3.1 Start Screen	66
6.3.2 Flow Screen	67
6.3.3 Main Menu Screen	67
6.3.4 Submenu Screen	68
6.3.5 Default Screen	78
6.4 Prompt Window	79
6.5 List of UPS Alarm and Fault Message	80
7 Communication	83
7.1 Connecting Built-in Ethernet Port	83
7.2 Connecting Serial Port Communication Cables	85
7.3 Installing Intelligent Card	85
7.3.1 Intelligent Card Port	85
8 Maintenance	87
8.1 Replacing Batteries	87
8.2 Fan Maintenance	88
8.3 Battery Maintenance	88
8.4 Cleaning UPS	90

8.5 Checking UPS State90

8.6 Checking UPS Functions90

9 Options 91

9.1 Option List91

10 Technical Specifications 93

11 Appendices i

Appendix A: LCD Parameters Setting i

Appendix B: Glossary v

This page intentionally left blank

1 Important Safety Instructions

IMPORTANT! This manual contains important safety instructions that must be followed during the installation and maintenance of the Vertiv™ Liebert® ITA2 1-3 kVA. Read this manual thoroughly, and the safety and regulatory information are available at [Compliance Regulatory Info](#).

Purpose of the Document

This document applies to Vertiv™ Liebert® ITA2 1-3 kVA UPS and cooling solutions which maintain optimal environmental control of technological ecosystems at minimal operating costs. This document gives an overview of the specifications, installation, commissioning, and maintenance procedures with troubleshooting from the user's perspective. The figures used in this document are for reference only.

Please read this manual carefully before installing, maintaining, and troubleshooting.

Styling used in this Guide

The styles used in the manual will be defined as mentioned in the following table:

Situation	Description
Warning/Danger/Caution	 WARNING! The Warning/Danger/Caution note indicates a hazardous or potentially harmful situation that can result in death or injury. It also indicates instructions that need to be adhered to, failing which may result in danger and safety issues thereby having an adverse effect on the reliability of the device and security. Even for practices not related to physical injury, to avoid equipment damage, performance degradation, or interruption in service, follow the warning instruction.
Note	NOTE: The Note section indicates additional and useful information. It also calls attention to best practices and industry-best protocols that are standardized and help make maximum utilization of the resources at hand. Helpful information related to the product also comes under the Note heading, helping the users with the definitions, concepts, and terminologies used in the manual.

Version History

Version	Revision Date	Remarks
V1	05/07/2022	Manual Part Code: 190321003302
V2	01/06/2023	Updated Global Guidelines

This page intentionally left blank

2 Special Declaration

Personnel Safety



CAUTION: Only trained engineers by the Vertiv or the representative of the Vertiv must install and commission this unit. Failure to comply with these precautions might risk the personnel safety or put the product in danger.



CAUTION: Read this product manual and the safety precautions carefully, before installing, and commissioning this unit. Failure to comply with these precautions might risk the personnel safety or put the product in danger.



CAUTION: This product is not intended for life support equipment application.



CAUTION: Do not attempt to dispose of batteries by burning them as this may result in a battery explosion. Failure to comply with these precautions might risk the safety of the personnel.

Product Safety

1. If this unit is required to be stored or remain de-energized for a long period, it must be placed in a dry and clean environment within a specified temperature range.
2. This unit must be operated only within the permissible environmental conditions. For details, refer to the section 10 , [Technical Specifications](#) on page 93 in this user manual.
3. The application of this product must be prohibited for the following environmental conditions:
 - In case the relative humidity and temperature exceed the permissible limits.
 - Subject to vibrations or shocks.
 - In presence of conductive dusts, corrosive gases, salts, or flammable gases.
 - Exposure to heat sources or strong electromagnetic interferences.

Disclaimer

The Vertiv disclaims any and all responsibility or liability for the defects or malfunction caused by the following:

- Application range or operating environment outside the specifications.
- Unauthorized modification, improper installation, or operation.
- Force majeure.
- Other actions not in compliance with the instructions in this manual.

Safety Precautions

This manual contains the information concerning the installation and operation of the Vertiv™ Liebert® ITA2 1-3 kVA UPS (hereinafter referred to as UPS). Please read this manual carefully prior to installation.

Please read the safety precautions very carefully before operating the unit in order to minimize the risk of any accident. The words "Caution," "Note," and "Warning" used in this user manual and on the product do not represent all the safety precautions to be observed and are only a supplement to the various safety precautions. Therefore, installation and operation personnel must receive the required training and follow the correct operations and all the safety points before operation.

When operating the Vertiv products, the operation personnel must observe the safety rules in the industry, the general safety points, and special safety instructions provided by the Vertiv.



WARNING! The UPS must be installed, commissioned, and serviced only by the engineers appointed by the manufacturer or its dealers. Failure to observe this could result in personnel safety risk, UPS malfunction and invalidation of warranty.



WARNING! It is not recommended to use the UPS in life support applications as it is designed primarily for commercial and industrial use.



WARNING! This is a Class C2 UPS product. It is recommended to take additional precautions to minimize radio interference in a residential environment as this unit may continue to generate radio interference.

Back feed protection



WARNING! Before operating the circuit, firstly, isolate the UPS and then check the dangerous voltage between the ports, and finally check the dangerous voltage between the dangerous voltage the ports and the earth.

Conformity and standards



WARNING! The UPS complies with 2014/35/EU (LVD), 2014/30/EU (EMC), 2011/65/EU (RoHS) and the following product standards for UPS:

IEC/EN 62040-1/AS 62040-1: General and safety requirements for UPS.

IEC/EN 62040-2/AS 62040-2: Class C2 compliant.

IEC/EN 62040-3/AS 62040-3: (VFI SS 111): Performance requirements and test methods.

The UPS installation should follow the above instructions and use the accessories specified by the manufacturer.



WARNING! When the UPS is operating, some parts have high voltage, therefore, contact with them directly or through moist objects will result in fatal risk.



WARNING! Before moving or rewiring the UPS, disconnect mains input power and the battery and make sure that the UPS is completely shut down. Otherwise, the output terminal may carry live voltage, presenting an electric shock hazard



WARNING! Liquid or other irrelevant external objects are prohibited inside the UPS.



WARNING! In case of a fire, a dry chemical fire extinguisher is essential. It is prohibited to use a foam fire extinguisher as it will cause electric shock.



WARNING! The output neutral line of the UPS is from the input, after the neutral line is suspended by the upstream protection devices, the output neutral line will be unplugged.



WARNING! It is recommended to use a UPS output cable that is less than 10 meters in length to prevent the radio frequency of the cable from affecting other electrical equipment.

High leakage current



WARNING! Earth connection is essential before connecting the input power (AC mains and battery included).

Earth leakage current not greater than 3.5 mA.

Transient and steady-state earth leakage currents, which may occur when starting the unit, should be considered when selecting instantaneous residual current circuit breaker (RCCB) or residual current detector (RCD).

Note that the earth leakage current of the load will be carried by RCCB or RCD.

This unit must be earthed in accordance with the local electrical codes.



WARNING! When selecting the UPS system upstream distribution protection equipment, ensure that it complies with the local electric regulations.

The specified upstream breakers are required to obtain the conditional short-circuit current rating, I_{cc} at 10 kA symmetrical rms. The specified upstream breakers should comply with an IEC 60947 series standard.

User serviceable components



WARNING! There are no user-serviceable components in the UPS. Do not remove the cover. Removing the cover may result in electric shock and will invalidate any implied warranty.

The UPS must fully comply with all safety regulations in the operator access area. Only trained technicians are permitted access to the dangerous voltage within the UPS. However, the risk of contracting these voltages is minimized because the components with hazardous voltage may be contacted only by using a tool to remove the protective cover. If you follow the general guidelines and use the recommended methods in this manual, the risk will subside.

Battery high voltage



WARNING! All the hardware service and maintenance of the battery are performed by the trained technicians.

Operation on the battery will result in electric shock and high short-circuit current, therefore, before operating the battery, the following should be observed:

- Remove the watches, rings, and other metal objects.
- Use the tools with insulation handle.
- Wear rubber glove, and shoes.
- Avoid placing the tools and metal objects on the battery surface.
- Cut off the charge power supply before connecting or disconnecting the battery terminals.
- Check to confirm whether the battery is accidentally earthed, and if so, disconnect the earthing. Contacting any earth battery parts will result in electric shock. Therefore, ensure that the battery is not earthed during installation and maintenance.

Battery manufacturers provide the details of the safety precautions to be observed when working on, or in the vicinity of the batteries, these precautions should always be followed implicitly. It is recommended to pay careful attention to the local environmental conditions, the provision of protective clothing, first aid, and fire-fighting facilities.

3 Product Introduction

The Vertiv™ Liebert® ITA2 1-3 kVA is an intelligent online UPS system with sine wave output developed by Vertiv. The UPS offers reliable and high-quality AC power to the precision instrument.

The rack/tower installation can be deployed depending on your requirements. It is applicable to supplying AC power to small scale computer center, network, communication system, automatic control system, and precision instrument.

This chapter introduces the features, model configurations, appearance, and components, operating principle, UPS state and operation mode, and specifications of the UPS.

3.1 Product Features

The Liebert® ITA2 1-3 kVA UPS products features include:

- The output power factor is 1, which enhances the UPS load capacity.
- Integrate the Ethernet port, support HTTP protocol, and use the web browser to achieve remote monitoring, no extra monitoring software is required.
- On-line double conversion efficiency up to 94% and ECO efficiency up to 98%, which provide more efficient products for customers.
- Operation and display panel with colorful LCD to help you learn about the UPS operation state and operating parameters. The LCD display will change according to the layout of the model.
- Tower installation and rack installation (2U thickness.)are optional to meet different installation requirements.
- Innovative design of the layout and whole machine process greatly improve the reliability of the product and enhance the reliability. Pass the harsh wet dust test and limit test.
- Two-way LLC circuit topology, high input power factor, wide input voltage range. The output is not affected by the power grid interference, suitable for the harsh power grid environment.
- Compared with the previous generation, the volume of the product is reduced by 10% on average. Space saving, easy to handle, and install.
- Full digital control platform and hardware design platform, which can adapt to worse unstable mains supply and load impact.
- Automatic recognition function of the battery module.

3.2 Model Configurations

The model configurations are shown in **Table 3.1** below.

Table 3.1 Model configurations

Model		Type	Description
1 kVA	Standard back-up model	ITA-01k00AS1102C00	The UPS can be connected to 10 battery modules, and automatically detect up to six
	Long back-up model	ITA-01k00AS1102C00	
2 kVA	Standard back-up model	ITA-02k00AS1102C00	
	Long back-up model	ITA-02k00AS1102C00	
3 kVA	Standard back-up model	ITA-03k00AS1102C00	
	Long back-up model	ITA-03k00AL1102C00	

3.3 Product Appearance and Components

3.3.1 Product Appearance

The UPS appearance is shown in **Figure 3.1** below.

Figure 3.1 Appearance of UPS



3.3.2 Product Components

Front panel

As shown in **Figure 3.2** below, the UPS front panel provides ventilation holes, operation and display panel, LED indicators, and functional keys.

Figure 3.2 UPS front panel

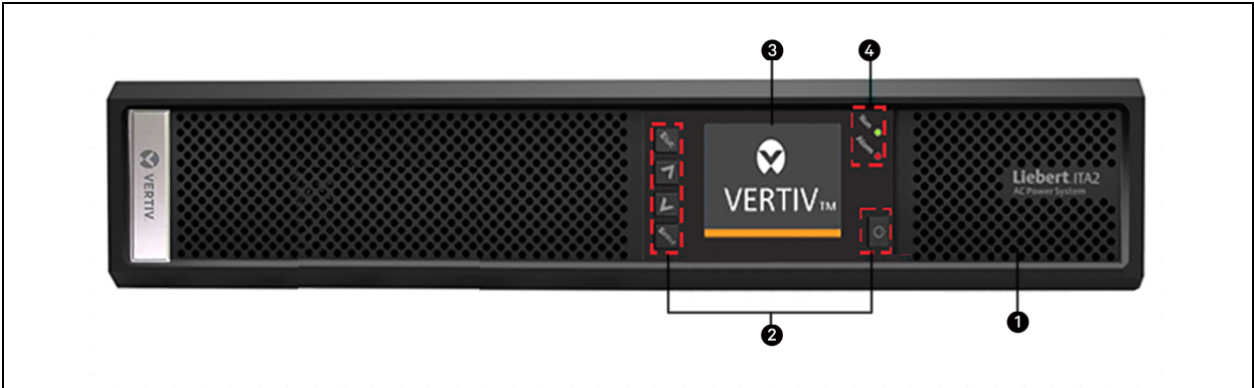

Parameter	Description
1	Ventilation holes
2	Functional keys
3	Operation and display panel
4	LED indicators

Rear panel

As shown in **Figure 3.3** below, the UPS rear panel provides dry contact port, I/O outlet, battery module port, Intellislot port, Ethernet port, USB port, and REPO port.

Figure 3.3 Vertiv™ Liebert® ITA2 (1 kVA) UPS rear panel

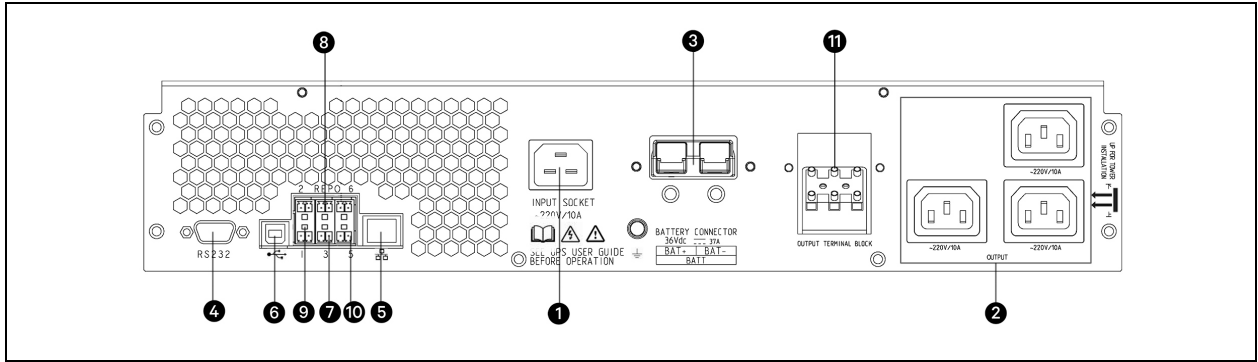

Figure 3.4 Vertiv™ Liebert® ITA2 (2 kVA) UPS rear panel

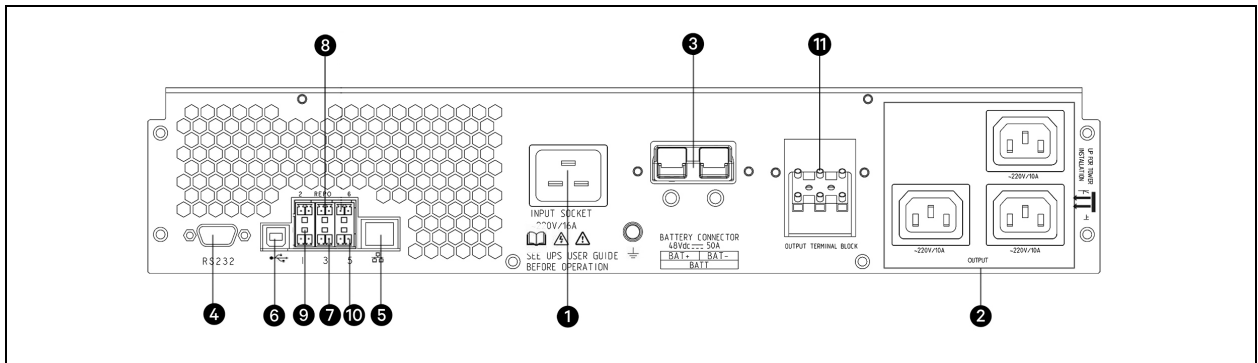

Figure 3.5 Vertiv™ Liebert® ITA2 (3 kVA) UPS rear panel

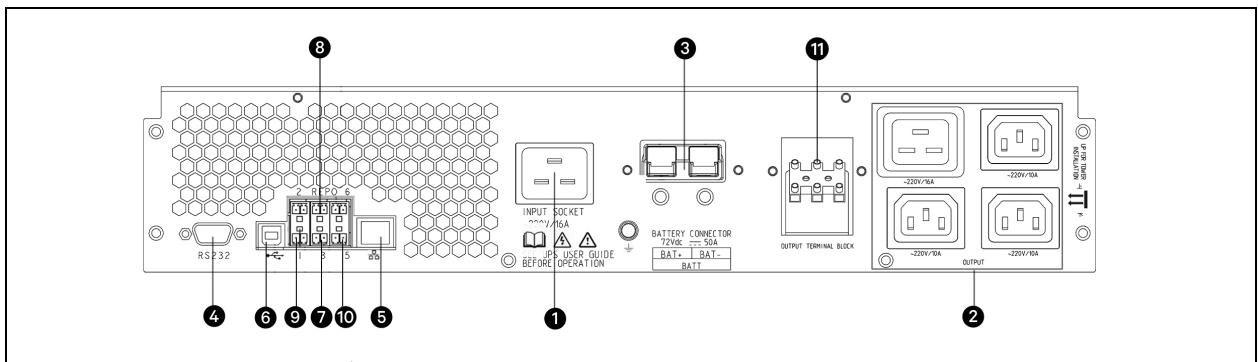

Table 3.2 Vertiv™ Liebert® ITA2 1-3 kVA UPS rear panel details

Parameter	Description
1	Input outlet
2	Output outlet
3	Battery module port
4	Intellislot port (DB9)
5	Ethernet port
6	USB port
7	Battery module number detection port
8	REPO port
9	Output dry contact
10	Input dry contact port
11	Output terminal block

NOTE: Non-authorized personnel are prohibited from opening the UPS chassis cover.

3.4 Operating Principal

The operating principle of the Vertiv™ Liebert® ITA2 1-3 kVA UPS is shown in Figure 3.6 below.

Figure 3.6 Vertiv™ Liebert® ITA2 (1-3 kVA) UPS operating principle

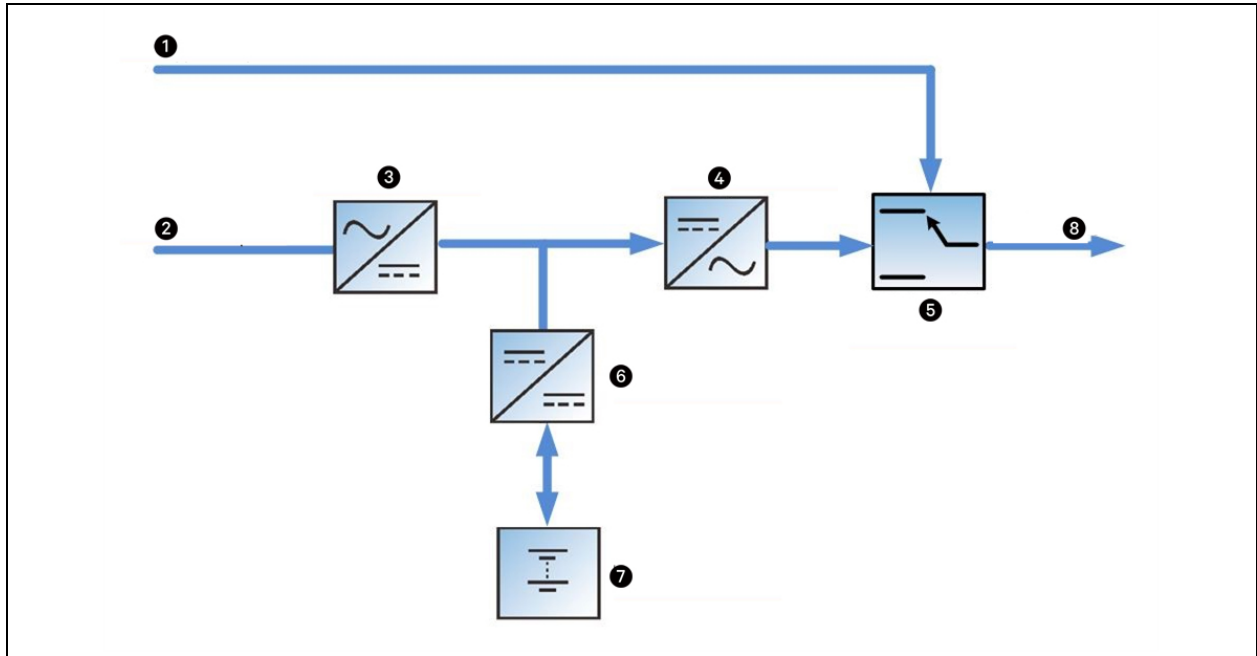

Parameter	Description
1	Bypass input
2	Mains input
3	Rectifier/PFC
4	Inverter
5	Output relay
6	DC/DC Converter
7	Battery
8	UPS output

1. The UPS consists of mains input (main and bypass), rectifier/PFC, charger, inverter, bypass, battery, DSP controller, and output.
2. When the mains is normal, the rectifier will start, and the charger will charge the battery string. Before turning on the UPS, the output voltage is bypass voltage, and the mains supplies power to the load through the bypass. After turning on the UPS, the electronic transfer switch connects the inverter output to the load, and the mains supplies DC power to the inverter through the rectifier/PFC circuit. The inverter then converts DC power into pure sine wave AC power and supplies the AC power to the load through the electronic transfer switch.
3. When the mains operates beyond the UPS input supply tolerance levels, the battery supplies the required power to the load through the rectifier/PFC circuit where the battery voltage is boosted, and then supplies to the Inverter where it converts DC into pure sinewave AC power.
4. After the input mains returns within tolerance levels, the UPS will automatically transfer from Battery mode to Normal mode, the mains supply DC power to the inverter through the rectifier/PFC circuit, and then the electronic transfer switch supplies AC power to the load.

3.5 UPS State and Operation Mode

For the LED indicators introduced in this section, refer to section 6.1.1 [LED Indicators](#) on page 63 .

The Vertiv™ Liebert® ITA2 1-3 kVA UPS state and operation mode include Normal mode, Bypass mode, Battery mode, ECO mode, Fault state and Maintenance Bypass mode. The operation schematic diagrams of Normal mode, Bypass mode, Battery mode, and Maintenance Bypass mode are shown in **Figure 3.7** on the next page to **Figure 3.9** on page 18.

3.5.1 Normal Mode

When the mains input is normal, the load is supplied with voltage-stabilizing and frequency-stabilizing power by the mains after processing of the rectifier and the inverter, and meanwhile, the charger is charging the battery. The operation mode is Normal mode.

In Normal mode, the run indicator (green) is on, the alarm indicator is off, and the buzzer is silence.

Figure 3.7 Vertiv™ Liebert® ITA2 1-3 kVA UPS operating principle (Normal mode)

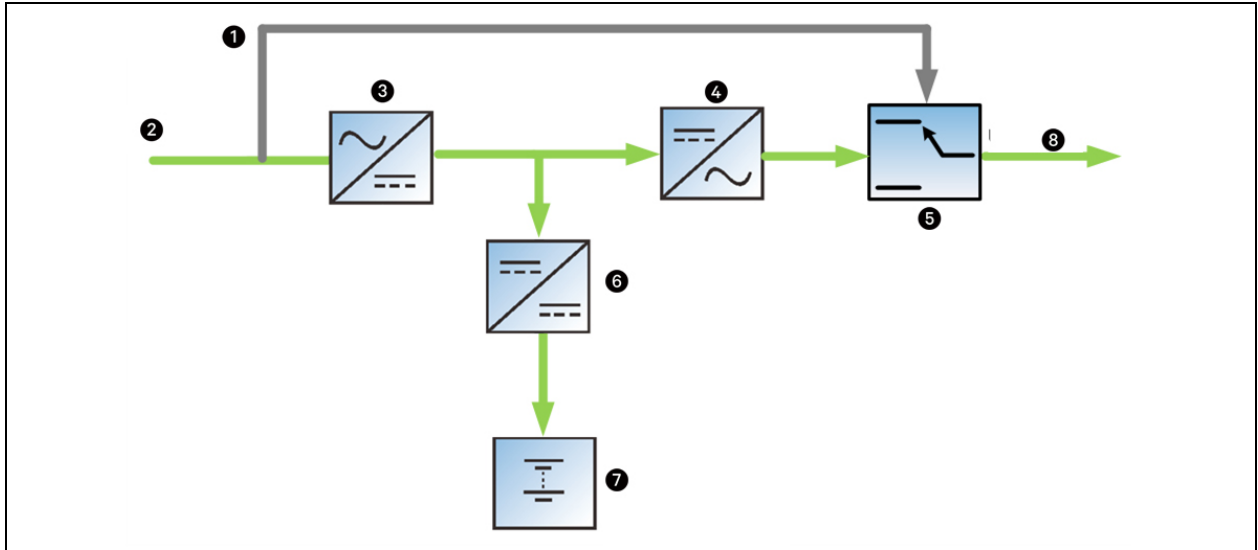

Parameter	Description
1	Bypass input
2	Mains input
3	Rectifier/PFC
4	Inverter
5	Output relay
6	DC/DC Converter
7	Battery
8	UPS output

3.5.2 Bypass Mode

If the overload overtime, inverter, or rectifier failure appears during the UPS operation in Normal mode, the UPS will transfer to Bypass mode, that is, the load is powered by the bypass source, which comes directly from the mains input. If the rectifier is normal, the internal charger will charge the battery.

In Bypass mode, the run indicator (green) is on, alarm indicator (yellow) is on, and the buzzer beeps every second. The 'Current' page in LCD will display 'On Bypass'.

Figure 3.8 Vertiv™ Liebert® ITA2 1-3 kVA UPS operating principle (Bypass mode)

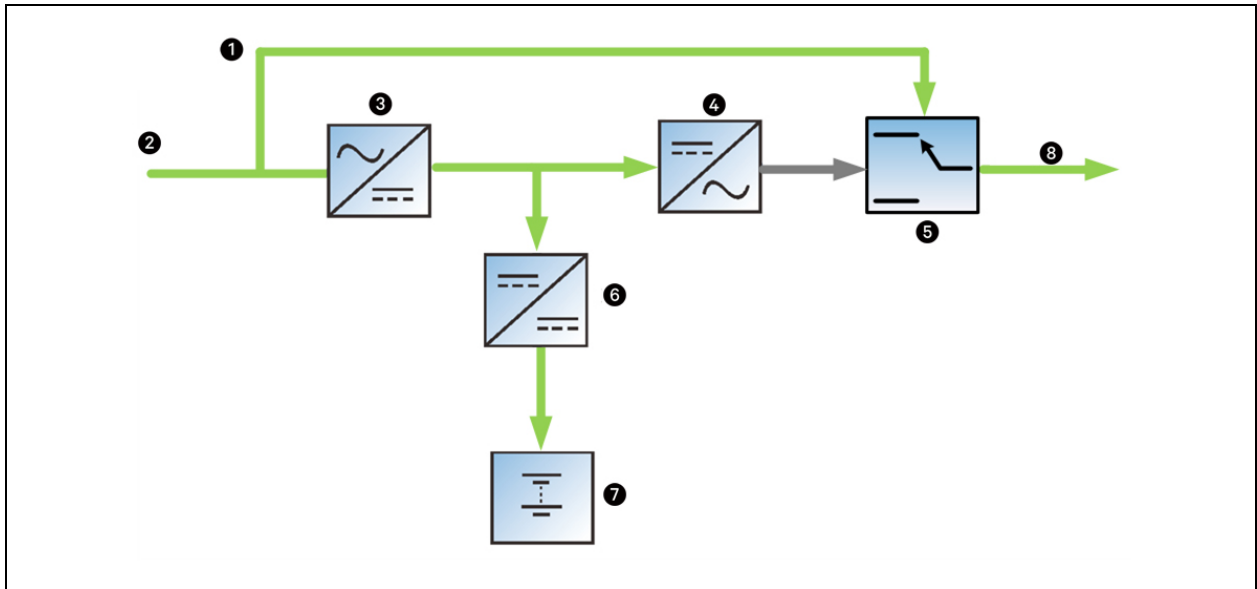

Parameter	Description
1	Bypass input
2	Mains input
3	Rectifier/PFC
4	Inverter
5	Output relay
6	DC/DC Converter
7	Battery
8	UPS output

NOTE: In case of mains failure or mains voltage out of range in Bypass mode, the UPS will shut down and stop the output.

3.5.3 Battery Mode

Upon mains failure or voltage out of range, the rectifier and internal charger will stop running, and the battery will supply power to the load through the inverter. In Battery mode, the run indicator (green) is on, alarm indicator (yellow) is on, and the buzzer beeps every second. The 'Current' page in LCD will display 'On Battery'.

Figure 3.9 Vertiv™ Liebert® ITA2 1-3 kVA UPS operating principle (Battery mode)

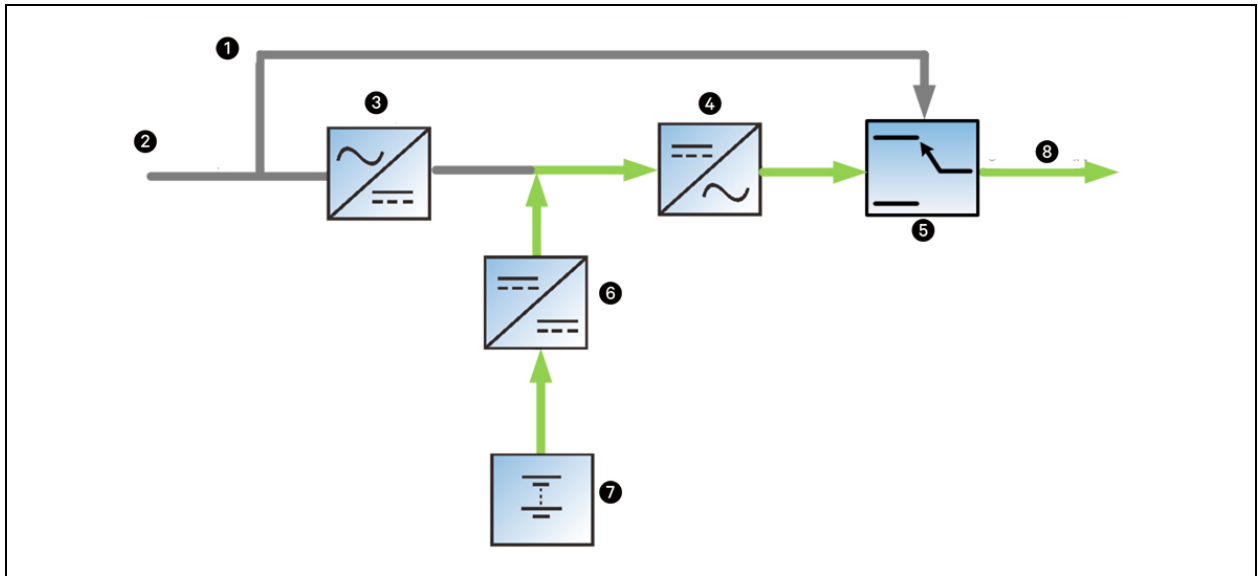

Parameter	Description
1	Bypass input
2	Mains input
3	Rectifier/PFC
4	Inverter
5	Output relay
6	DC/DC Converter
7	Battery
8	UPS output

NOTE: The battery has been fully charged before delivery. However, some loss of capacity is inevitable during transportation and storage. Therefore, it is important to charge the battery for eight hours before the UPS is first put into operation to ensure it can provide adequate backup time.

NOTE: The Vertiv™ Liebert® ITA2 (1-3 kVA) UPS supports a cold start function, while this function is activated, UPS can be powered using battery mode without the availability of an input power supply. Therefore, the battery power can also be utilized independently for improving the system availability.

3.5.4 ECO Mode (for UPS Equipped with Battery only)

In ECO mode, the load is powered by a bypass when the bypass voltage is normal, and the load is powered by an inverter when the bypass voltage is abnormal. ECO mode is an energy-saving operation mode. For power equipment insensitive to power grid quality, it is recommended to can use the ECO mode for power supply through the bypass to reduce the power loss.

NOTE: In ECO mode, if the bypass failure or abnormal bypass voltage appears when the output is not overloaded, the UPS will transfer to Normal mode. However, if the bypass failure or abnormal bypass voltage appears when the output is overloaded, the UPS will not transfer to Normal mode but shut down the bypass.

NOTE: In ECO mode, the efficiency of the UPS is up to 98%.

NOTE: ECO mode can be activated by the UPS only if a battery is present.

3.5.5 Fault State

In Normal mode, the UPS will switch to Bypass mode if the inverter failure or UPS over-temperature occurs. In Battery mode (without bypass mains), the UPS will shut down and stop the output if the inverter fails or UPS over-temperature occurs. In the UPS Fault state, the alarm indicator (red) will be solid, the buzzer will continue to beep, and the corresponding fault information will be displayed on LCD.

This page intentionally left blank

4 UPS Installation

This chapter introduces the installation, cable connection of the Vertiv™ Liebert® ITA2 1-3 kVA UPS.

Each site has its own distinct feature, so this chapter provides general installation procedures and methods for the installation engineer who should conduct the installation according to the actual conditions.

Professional installation



WARNING! The UPS should be installed only by the trained engineer in accordance with the information provided in this section. In the event of any problems, contact your Vertiv representative immediately.

The UPS must NOT be switched ON without the approval of the commissioning engineer.

For any other additional equipment which is not introduced in this manual, detailed instructions about mechanical installation guidelines and electrical installation guidelines are delivered with the equipment.

4.1 Unpacking and Inspection

Place the cardboard box vertically, unpack the cardboard box, and remove the UPS. Refer to the **Figure 4.1** below. Refer to **Table 4.1** below for the UPS size and weight with package details.

Table 4.1 Vertiv™ Liebert® ITA2 1-3 kVA UPS size and weight (with package)

Specification	Size (W×D×H) mm	(Gross weight) (KG)
1 kVA	547×262×610	18.8 (Standard back-up) 10.3 (Long back-up)
2 kVA	617×262×610	23.1 (Standard back-up) 11.8 (Long back-up)
2 kVA	687×262×610	30.1 (Standard back-up) 13.4 (Long back-up)

Figure 4.1 Unpacking

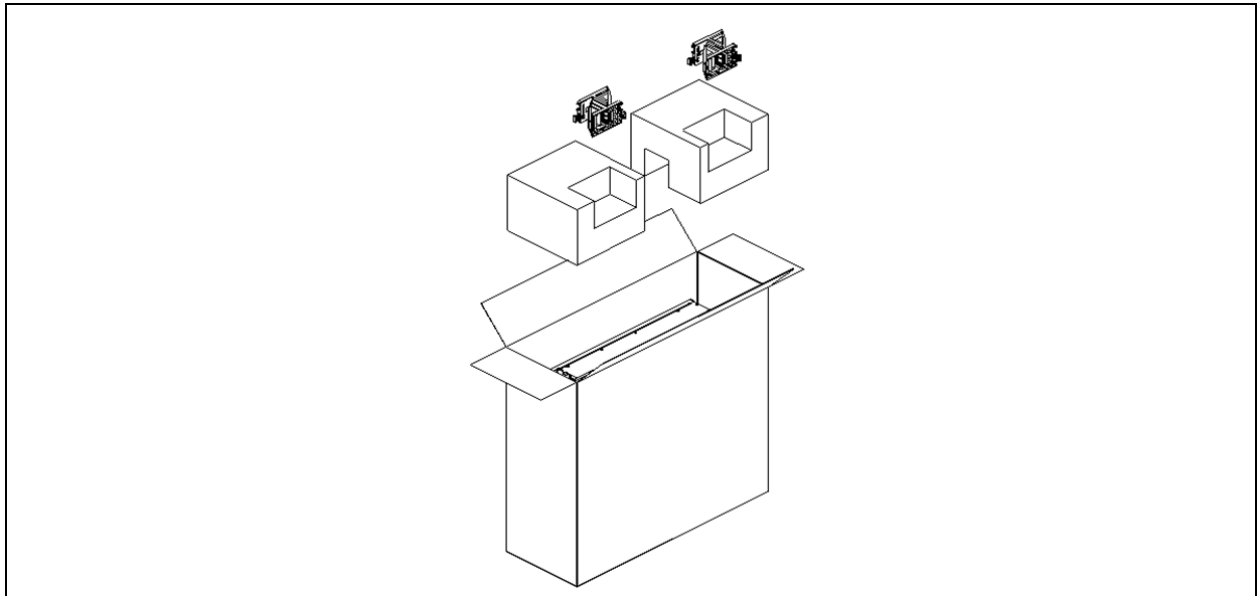

4.2 UPS Moving



WARNING! It is prohibited to move the UPS through the brackets.

The UPS cabinet can be moved by human, or forklift, or other similar lifting equipment.

4.3 Installation Preparation

4.3.1 Location

To extend the UPS service-life, the selected location must comply with following:

1. Convenient wiring
2. Adequate operator access area
3. Good ventilation to meet the heat dissipation requirements
4. No corrosive gas, such as sulfur dioxide and so on
5. No excessive moisture or heat source
6. No excessive dust
7. Compliance with fire-fighting requirements
8. Operating temperature compliant with the specifications, refer to the **10** on page 93 for details

4.3.2 Environmental Requirement

UPS room

The UPS is designed for indoor installation, which should be installed in a clean and well-ventilated environment, to keep the ambient temperature within the specifications.

The internal fans provide forced air cooling for the UPS. Cooling air enters the UPS through the ventilation holes on the front panel and exhausts the hot air through the back-ventilation holes. Therefore, do not obstruct the ventilation holes. Maintain at least 200 mm clearances between the front, rear of the UPS and the wall or adjacent equipment. (Refer **Figure 4.2** on the next page), to avoid obstructing the UPS ventilation and heat dissipation. Otherwise, the UPS internal temperature will rise, which will shorten the UPS service-life.

If necessary, an indoor exhaust fan should be installed to keep the indoor temperature from rising. An air filter should be used in a dusty environment where the UPS is to be operated.

Space reserved

Figure 4.2 Installation clearances (top view of rack installation)

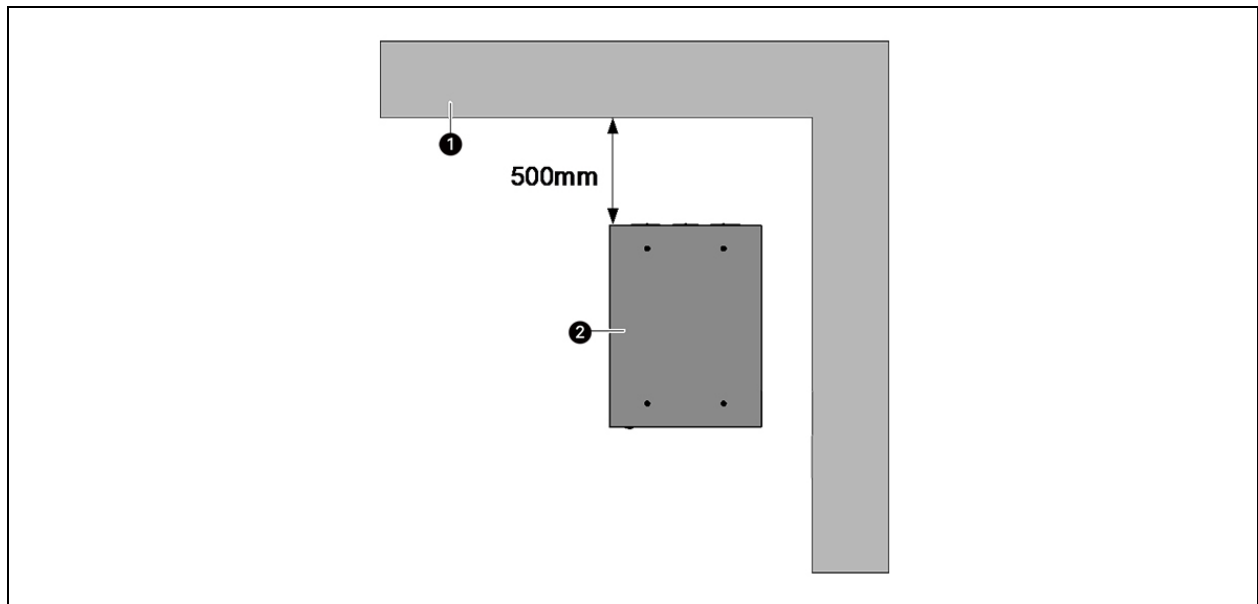

WARNING! The UPS should only be installed on the concrete surface or other non-flammable surfaces.

NOTE: As shown in **Figure 4.3** on page 28, the demonstration of the clearance between the rear panel of the cabinet and the wall is 500 mm. The clearance should not be less than 200 mm, it needs to be considered according to the actual situation for the sake of maintenance convenience.

Battery room

A small amount of hydrogen and oxygen will be generated at the end of battery charging, therefore, you must ensure that the fresh air ventilation of the battery installation environment meets the EN50272-2001 requirements.

The ambient temperature of the battery should keep constant, for the ambient temperature is the main factor to affect the capacity of the battery and service-life. The battery standard operating temperature is 20 °C, operation above this temperature will shorten the battery life, and operation below this temperature will reduce the battery capacity. If the battery average temperature in operation increases from 20 °C to 30 °C, the battery life will be reduced by 50%; if the battery temperature in operation exceeds 40 °C, the battery life will be decreased exponentially. In normal situation, the allowable ambient temperature for the battery is between 15 °C to 25 °C. The battery should be kept away from the heat source and air outlet.

When the UPS uses an external battery, you must install a battery protective device (such as a fuse or circuit breaker) close to the battery and use the shortest wiring distance for the connection between the protective device and the battery.

Storage environment

When the UPS does not need to be installed immediately, the UPS must be stored indoors to be protected from the excessive moisture or an over-temperature environment. The battery requires a dry and low temperature, well-ventilated environment for storage, and the most suitable storage temperature is 20 °C to 25 °C.

Battery hazards



WARNING! During the battery storage, the battery must be periodically charged according to the battery instructions. When charging the battery, you can connect the UPS to the mains temporarily to charge and activate the battery.

4.3.3 Installation Tools



WARNING! The installation tools utilized in live operation must be properly insulated for safety purpose.

Tools in **Table 4.2** below are for reference only; please follow the actual requirement for on-site installation and connection.

Table 4.2 List of installation tools

















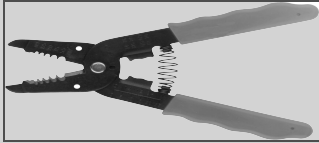

Name	Drawing	Name	Drawing
Electric hand drill		Adjustable wrench	
Slotted screwdriver		Cross head screwdriver	
Stepladder		Forklift	
Drill		Wire cutting plier	
Claw hammer		Diagonal cutting plier	

Table 4.2 List of installation tools (continued)

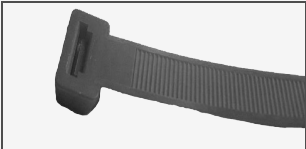
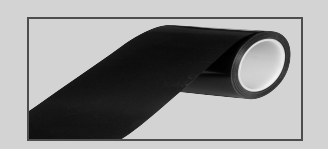
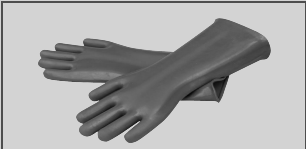
Name	Drawing	Name	Drawing
Insulating shoes		Antistatic gloves	
Electrician knife		Cable tie	
Insulating tape		Insulating gloves	
Crimping plier		Heat shrinkable tube	
Insulated torque wrench		Torque screwdriver	
Multimeter		Clip-on ammeter	

4.4 External Protective Devices

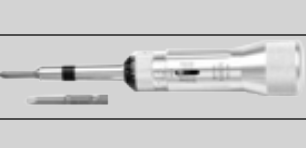
The circuit breaker or other protective devices must be installed at the external AC input end of the UPS. This section provides the general guidance for qualified installation engineer. The qualified installation engineer should comply with the local wiring regulations and other related standards.

4.4.1 Overcurrent

The appropriate over-current protective device should be installed on the mains input power distribution, and the current capacity of the power cable and the system overload requirements should be taken into account in installation. For the thermomagnetic circuit breaker, refer to the **Table 4.2** on page 26.

4.4.2 Earth Leakage Current

The residual current detector (RCD) for the UPS upstream input power distribution should be:

1. Sensitive to the DC unidirectional pulse (level A) in the power distribution network.
2. Insensitive to the transient current pulse.
3. General sensitivity type, settable: 0.3 A to 1 A.

The residual current circuit breaker (RCCB) must be sensitive to the DC unidirectional pulse (level A) in the power distribution network, but insensitive to the transient current pulse, as shown in **Figure 4.3** below respectively.

Figure 4.3 RCCB symbols

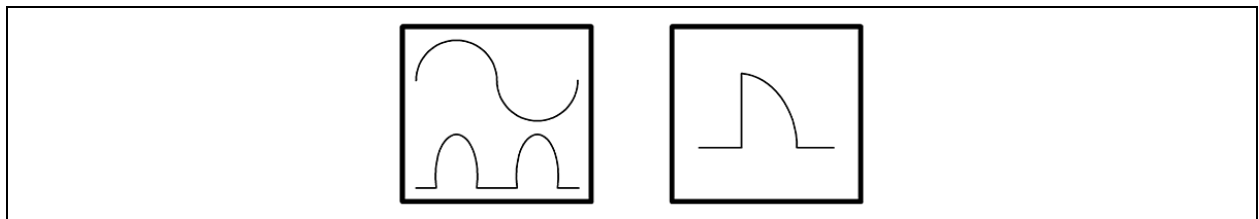

The earth leakage current fed by the RFI filter in the UPS should be less than 3.5 mA. We recommend confirming the sensitivity of each differential device of the upstream input power distribution and downstream power distribution (to load).

4.4.3 Battery Input

If the Vertiv battery module is selected, the battery module is equipped with an overcurrent protection device. Otherwise, the battery module shall provide DC compatible circuit breaker to provide over-current protection for UPS and its batteries. The protective device specification is shown in **Table 4.2** on page 26.

4.5 Mechanical Installation

Two installation modes are available: tower installation and rack installation. It is possible to select an appropriate installation mode according to the actual conditions.

4.5.1 Tower Installation

1. Take out the support bases from the accessories, assemble a pair of support bases and a support base extension (accessory) together through the fastenings, as shown in **Figure 4.4** below, and place them onto the flat installation table.

Figure 4.4 Connecting the support base with support base extension

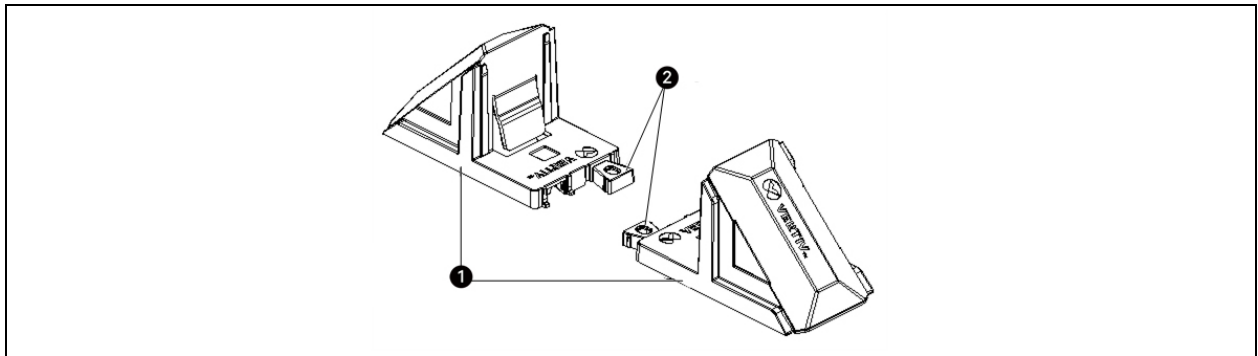

Parameter	Description
1	Support base
2	Fastening

2. If battery module installation is necessary, take out other support base extensions delivered with the battery module, and then assemble the support base extensions and the support bases through the fastenings, as shown in **Figure 4.5** below.

Figure 4.5 Connecting the support base with support base extension (If battery module installation is necessary)

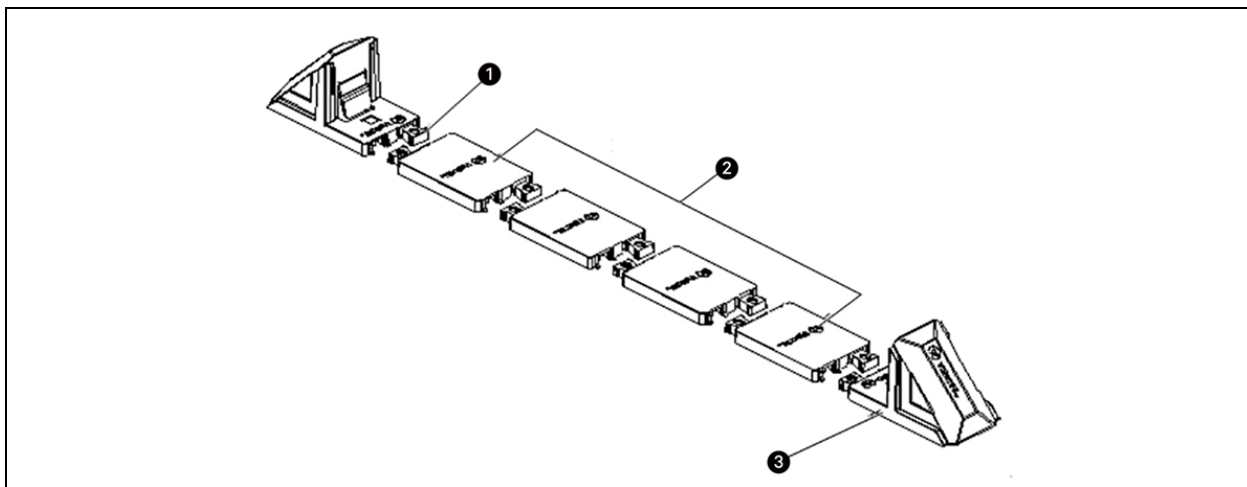

Parameter	Description
1	Fastening
2	Support base extension
3	Support base

- 3. Place the UPS on the support bases and support base extensions, as shown in **Figure 4.6** below. The two sets of support bases are placed as far apart as possible to prevent the UPS from toppling. It is recommended to maintain a 70 mm distance between the front and rear panels of UPS and the corresponding support bases.

Figure 4.6 UPS and battery modules Installation complete

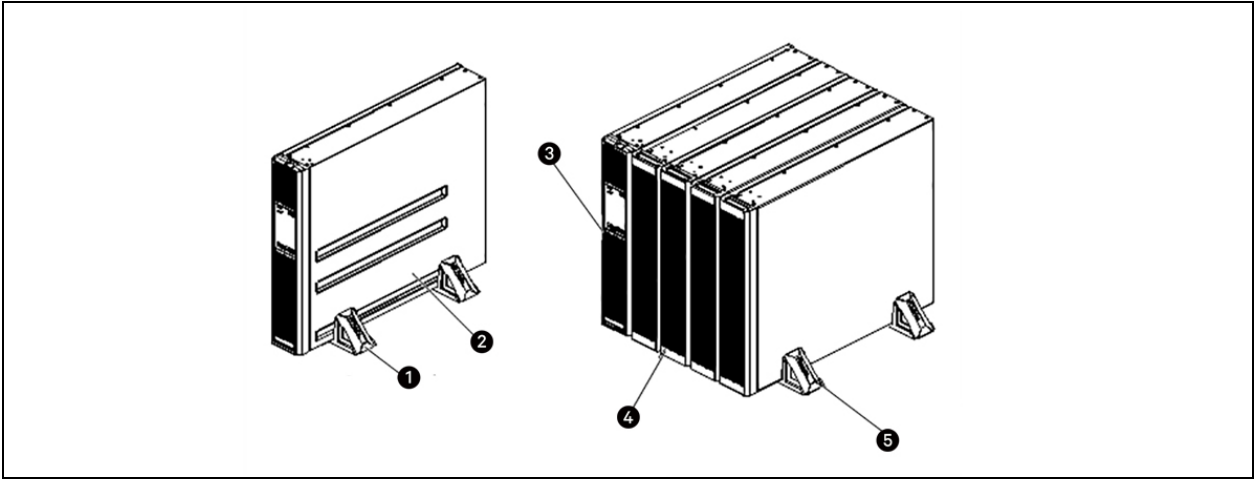

Parameter	Description
1	Support base
2	UPS
3	UPS
4	Battery module (4 PCS)
5	Support base

4.5.2 Rack Installation

Installation procedures for UPS

1. Use eight M4×8 screws to fix the two brackets (accessories) respectively on both sides of the UPS front panel, as shown in **Figure 4.7** below.

Figure 4.7 Installing brackets

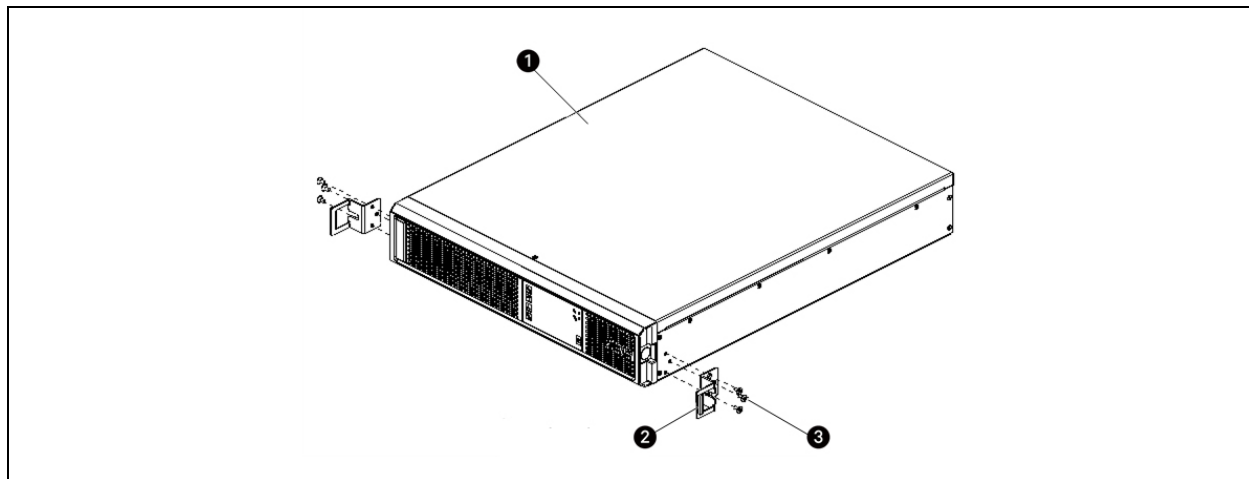

Parameter	Description
1	UPS
2	Bracket (2 PC)
3	Screw (8 PC)

NOTE: It is prohibited to move the UPS through the brackets.

2. Install the guide rails

The UPS adopts 2U guide rails for installation, and the installation procedures are as follows:

- a. Take out the guide rails (one left guide rail and one right guide rail), guide rail screws from the package, distinguish the left guide rail and right guide rail according to **Figure 4.8** below, and confirm its retractable function respectively.

Figure 4.8 Appearance of the guide rail

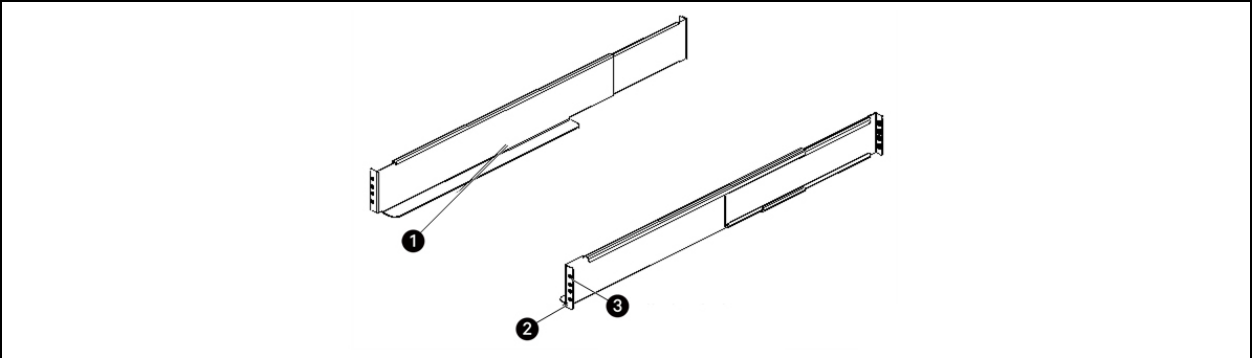

Parameter	Description
1	Left guide rail
2	Right guide rail
3	Installation hole

The guide rail screw is shown in **Figure 4.9** below.

Figure 4.9 Appearance of the guide rail screw

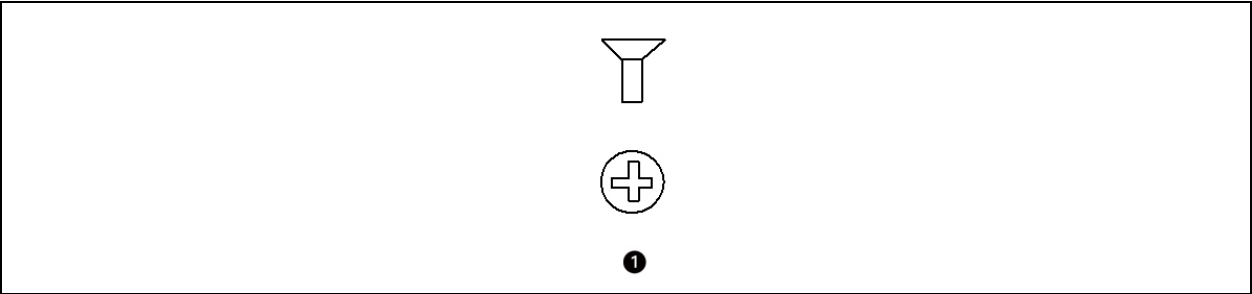

- b. Adjust the length of the guide rail according to the dimensions of the rack.
- c. Align the installation holes of the guide rail with the square holes of the rack, fix the guide rail onto the rack through the guide rail screws (totally eight), each left guide rail and right guide rail need four guide rail screws, as shown in **Figure 4.10** below.

Figure 4.10 Installing the guide rail

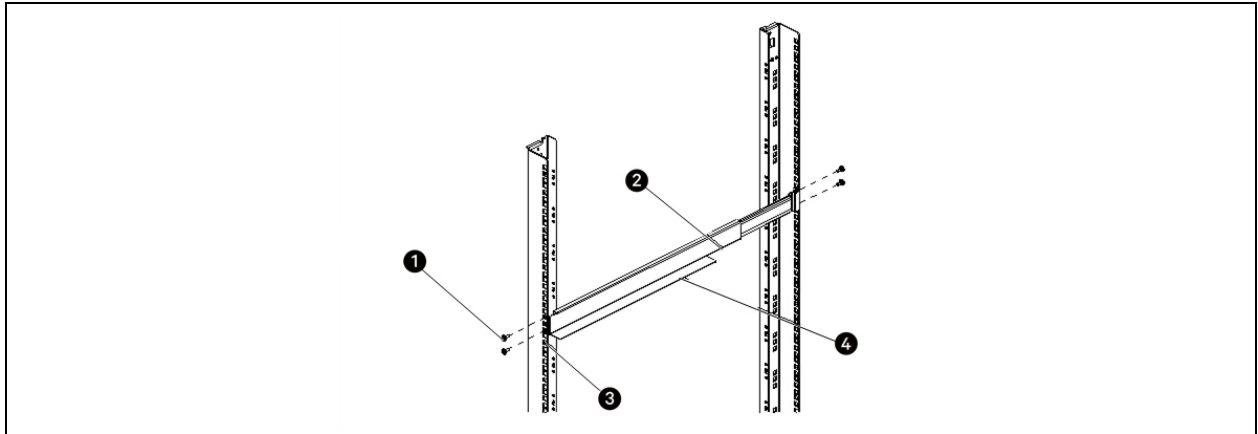

Parameter	Description
1	Guide rail screw (4 PCS)
2	Guide rail
3	Square hole
4	Guide rail holder

NOTE: The guide rail holder must be close to the front of the rack.

NOTE: Any end of one guide rail has three installation holes (refer to the **Figure 4.8** on the previous page), do not use the installation hole in the middle when fixing the guide rail. We recommend using the top and bottom installation hole (from top to bottom, installation hole 1 and installation hole 4).

The guide rail installation is finished, as shown in **Figure 4.11** below.

Figure 4.11 Guide rail installation completed

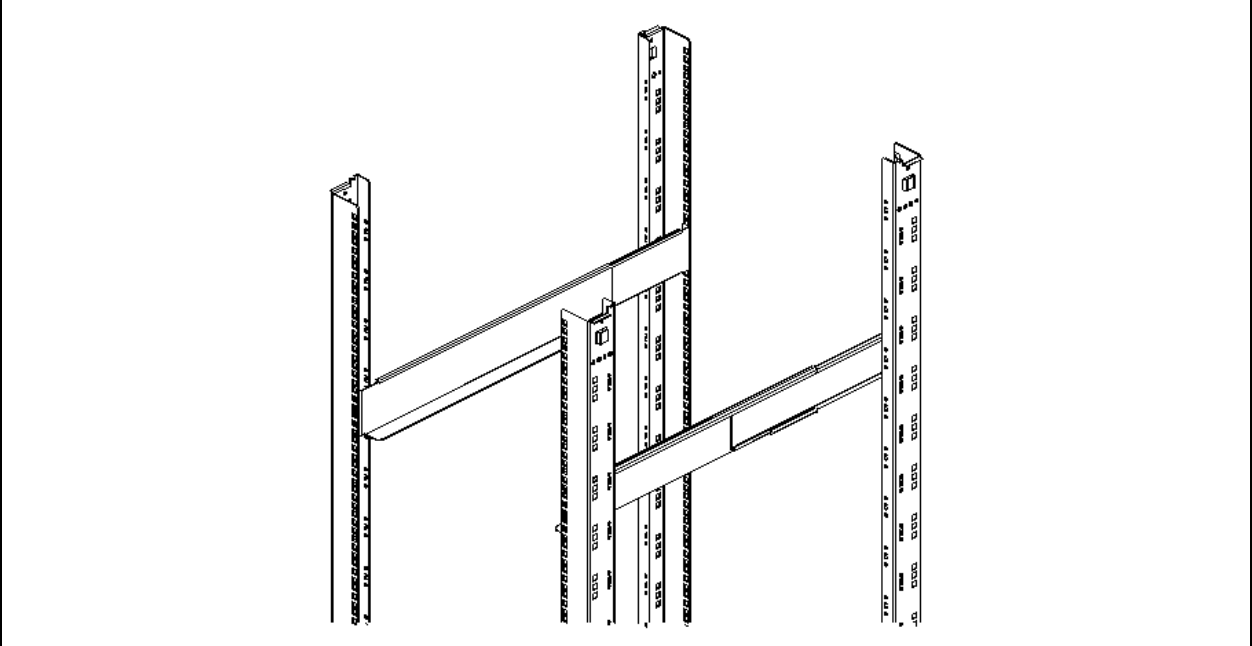

- Place the UPS on the guide rails in the rack and push it completely into the rack. Use four screws to fix the UPS in the rack through the brackets, as shown in **Figure 4.12** below.

Figure 4.12 Installing the UPS

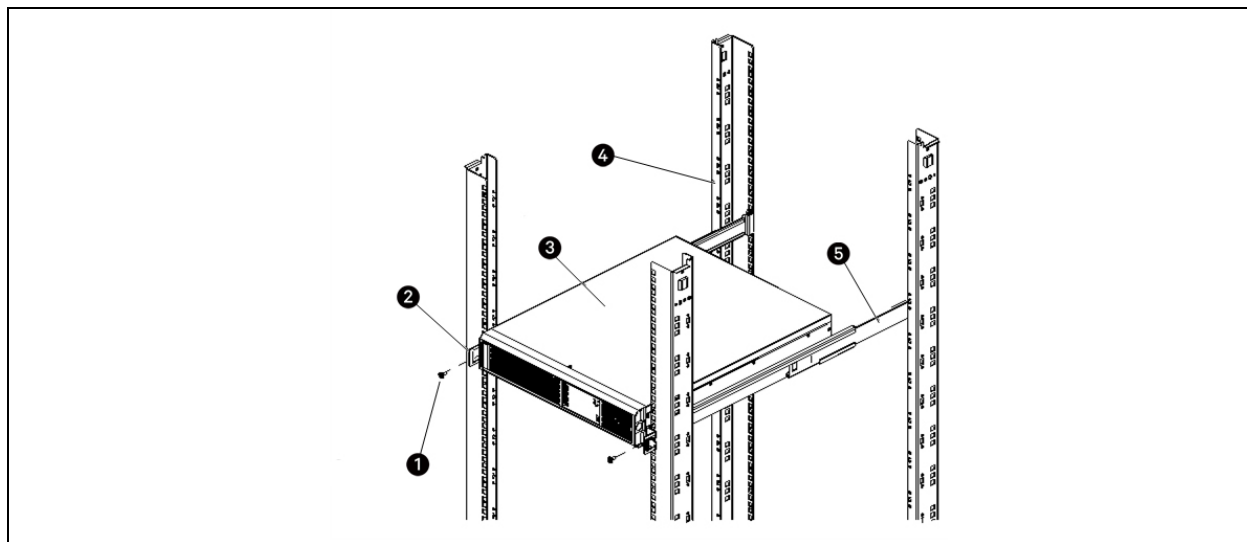

Parameter	Description
1	Screws (4 PCS)
2	Bracket
3	UPS
4	Rack
5	Guide rail

Installation procedures for UPS with battery modules

1. The battery module installation method is exactly the same as the UPS installation method. Repeat the above installation steps, install the battery modules and UPS to the rack one by one (4 battery modules are installed here). After all the installation is completed, as shown in **Figure 4.13** below.

NOTE: Install the battery modules first, start the installation from the bottom, and then place the UPS onto the top

NOTE: It is prohibited to move the UPS through the brackets.

NOTE: Two persons or more are required for the installation.

Repeat the preceding procedures to install and fix the four battery modules and a UPS in the rack one by one, as shown in **Figure 4.13** below.

Figure 4.13 Installation of UPS with battery modules

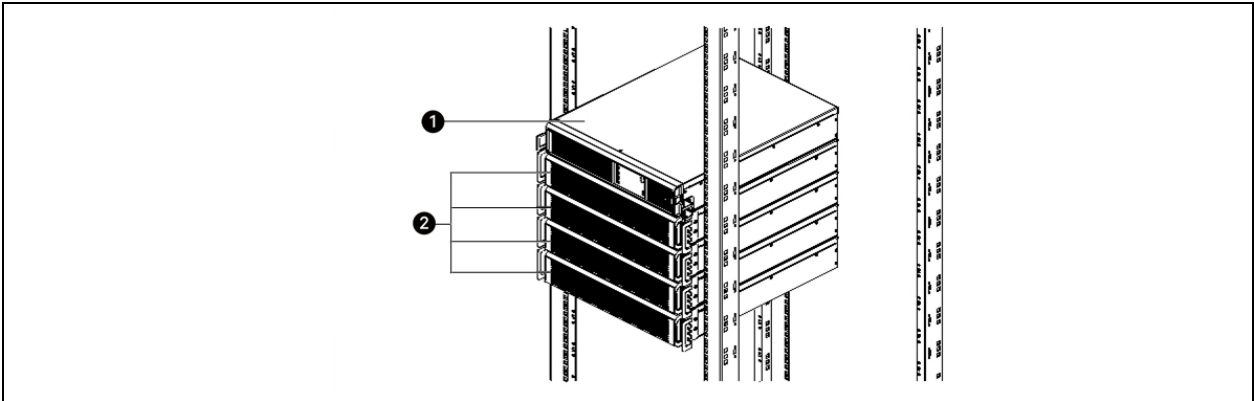

Parameter	Description
1	UPS
2	Battery module (4 PCS)

4.6 Connecting Power Cables

The rear panel of the UPS provides an input plug and an output socket, refer to the section 3.3.2 [Product Components](#) on page 11 for details. If the battery cabinet is configured, the battery cable is shipped with the battery cabinet.

4.6.1 Connecting Input Plug and Load

NOTE: Ensure that all loads are shut off.

NOTE: Prepare AC input power supply. According to local regulations, the input power must be properly protected and reliably grounded by circuit breaker.

NOTE: Refer to the **Table 4.3** below for the recommended capacity of the circuit breaker.

Table 4.3 Recommended capacity for UPS I/O circuit breaker

Model	External input circuit breaker	Battery circuit breaker
1 kVA (Long back-up, standard back-up,)	10 A	63 A
2 kVA (Long back-up, standard back-up,)	16 A	63 A
3 kVA (Long back-up, standard back-up,)	20 A	63 A

Connection procedures:

1. Connect the load to the output socket on the rear panel of the UPS. (Note: a single output socket must not carry more load than the capacity identified on the rear panel of the UPS.)
2. Connect the AC input to the UPS input socket using the attached input cables.

4.6.2 Connecting Battery Cables

NOTE: The batteries in the battery cabinet must be of the same manufacturer, the same model, the same capacity, and each battery rated voltage of 12 V.

NOTE: The external battery capacity limit of 1 kVA (long back-up) is not less than 7 Ah, factory default 7 Ah; the external battery capacity limit of 2 kVA and 3 kVA (long back-up) is not less than 8 Ah, factory default 8 Ah.

NOTE: Three batteries in series for 1 kVA, and the rated battery voltage is 36 V; Four batteries in series for 2 kVA, and the rated battery voltage is 48 V; Six batteries in series for 3 kVA, and the rated battery voltage is 72 V.

NOTE: Before connecting the battery cables, confirm that the actual battery cell number and capacity are consistent with the parameter settings on the LCD menus.

NOTE: It is prohibited to reverse the polarity of the battery cables.

NOTE: Before replacing the battery, module and connecting the battery cables, disconnect the DC battery MCB, power off the UPS completely, and conduct isolation protection on the terminals.

NOTE: It is recommended that the battery cable should not be longer than 10 meters. Otherwise, the UPS cannot operate normally.

NOTE: Shut off the battery circuit breaker before using the battery module.



WARNING! It is recommended to pay special attention when wiring the battery. Connect the cables between UPS and the battery module in strict accordance with the positive, negative and PE cables marked by the UPS, and do not forget to automatically detect the cables in connection with the number of battery modules.

Connecting long backup model and customer battery cabinet

The recommended type of wire diameter and OT terminal for connecting the long backup model and user battery cabinet are shown in **Table 4.4** below.

Table 4.4 Wire diameter and OT terminal for connecting long model and user battery cabinet

Cable CSA (Unit: mm ²)	Terminal type
Wire diameter >=6 or above 10 AWG	OT 6-5

It is recommended to follow the specified wire diameter and OT terminal model in **Table 4.3** on page 38. when wiring the battery cables. Special consideration should be given to the wiring practices and safety precautions in order to prevent safety issues

The schematic diagram of the cable connection of the external battery string for the self-distribution by the user is shown in **Figure 4.14** on the facing page.

NOTE: Between the battery string and the UPS, the DC battery circuit breaker must be configured. The circuit breaker specifications are selected according to the specifications recommended in Table 4.2 on page 26.

NOTE: Battery number shall be strictly connected according to 4.5.2 Rack Installation on page 32 . For lead-acid batteries with rated voltage of 12 V, 1 kVA/2 kVA/3 kVA models shall be connected in series with 3/4/6 batteries respectively. Too many or too few series connection will cause the risk of UPS damage.

Figure 4.14 Battery string connection principal diagram

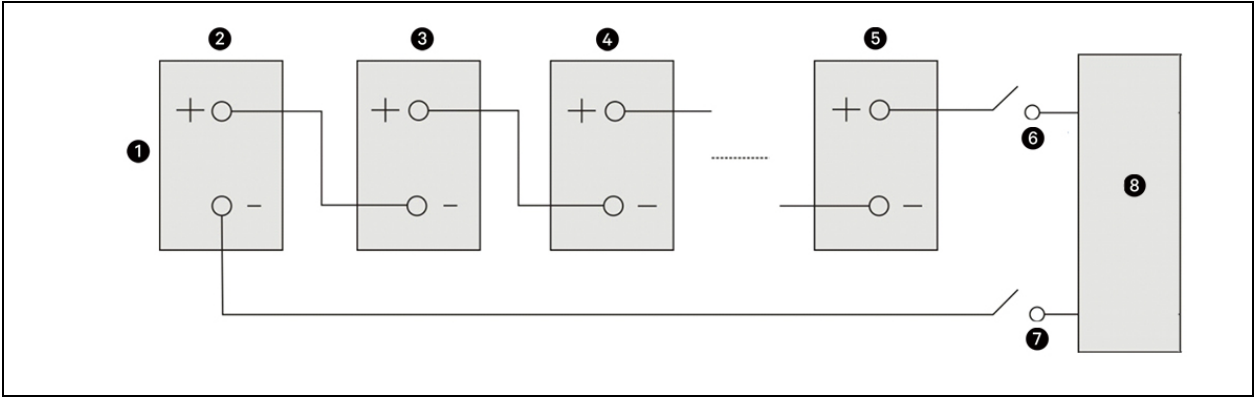

Parameter	Description
1	Battery module
2	First block
3	Second block
4	Third block
5	Sixteenth block
6	BAT+
7	BAT-
8	UPS

This page intentionally left blank

5 UPS Operation Instructions

This chapter gives a detailed description of the Vertiv™ Liebert® ITA2 1-3 kVA UPS operation procedures.

During the operation, the buzzer alarm may appear, at this point, you can press the  key for three seconds to silence.



WARNING! The parts located behind the protective covers can only be accessed by authorized personnel. To access these parts it is required to remove the protective cover by deploying the tools, only qualified service personnel are authorized to remove such covers. Only qualified service personnel are authorized to remove such covers. Unauthorized access is strictly prohibited.

5.1 UPS Start-Up

The start-up procedures must be performed only after the installation is completed, the system has been commissioned by an authorized engineer, and the external input MCBs are closed.



WARNING! This procedure results in the application of the mains voltage to the UPS output terminals. Confirm that the load power is safe, if there is a load to be connected with the UPS output terminal. If the load is not ready for accepting the power ensure that the load is isolated from the UPS output terminal.



Check before startup:

1. Whether the UPS input plug and output socket are plugged correctly and properly.
2. Check the battery installation and wiring connection are correct, and the polarities of the positive and negative terminals of the battery are correct.
3. Whether the communication cable is plugged correctly and properly.
4. Measure and confirm that the mains voltage and frequency are normal.

Startup steps are as follows:

1. Close the UPS external input circuit breaker and output circuit breaker sequentially.
2. The rectifier starts approximately 30 seconds after it enters its normal operating state.
3. Hold the power button for 2 seconds until the LCD pops up the confirmation dialog box.

NOTE: If the battery is not available, no dialog box appears when pressing and holding the power button.

4. Use  or  move the cursor, press the  key to select "Yes", then the running indicator (green) flashes, the inverter is on, and the running indicator is solid on.
5. Check whether the inverter output voltage is normal.
6. If the battery is not connected, the alarm indicator will turn yellow. If the battery is accessed, the alarm indicator will remain inactive (muted).
7. When starting the UPS for the first time, the start guide must be opened in order to set the basic parameter settings of the UPS. The section 5.2 [Initial Start-up Guidance](#) on the facing page describes the setup guide. For detailed instructions on UPS display functions and settings, refer to the Chapter 6 [Operation and Display Panel](#) on page 61.

5.2 Initial Start-up Guidance

When the Vertiv™ Liebert® ITA2 1-3 kVA UPS is in the initial start-up state, the interface shown in **Figure 5.1** below is displayed to guide the user to set basic parameters of the UPS.

Please refer to the section 6.1.3 [LCD and Functional Keys](#) on page 64 for instructions on the use of UPS keys and operate the system according to the function of each key.

Welcome page

Click **Next** to start the guidance.

Figure 5.1 Initial start-up guidance (Welcome page)

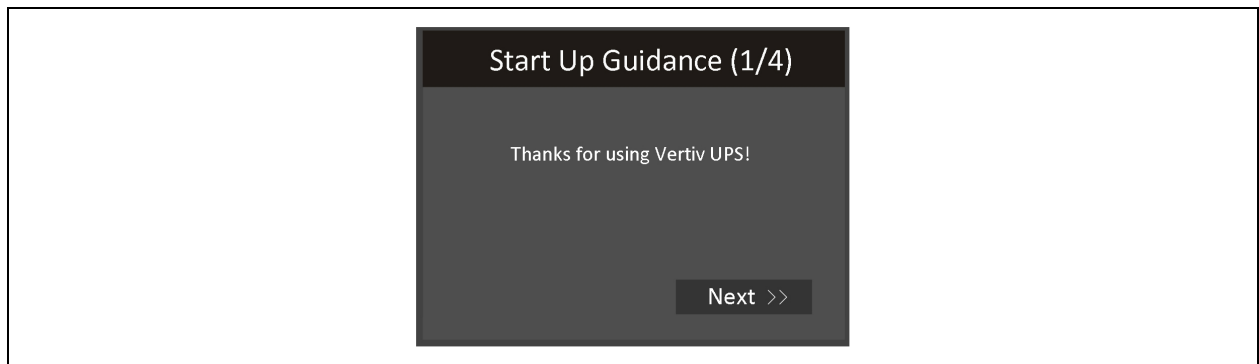

Language, date and time page

On this page, you can set the language, date and time you need.

Figure 5.2 Initial start-up guidance (Language, date and time page)

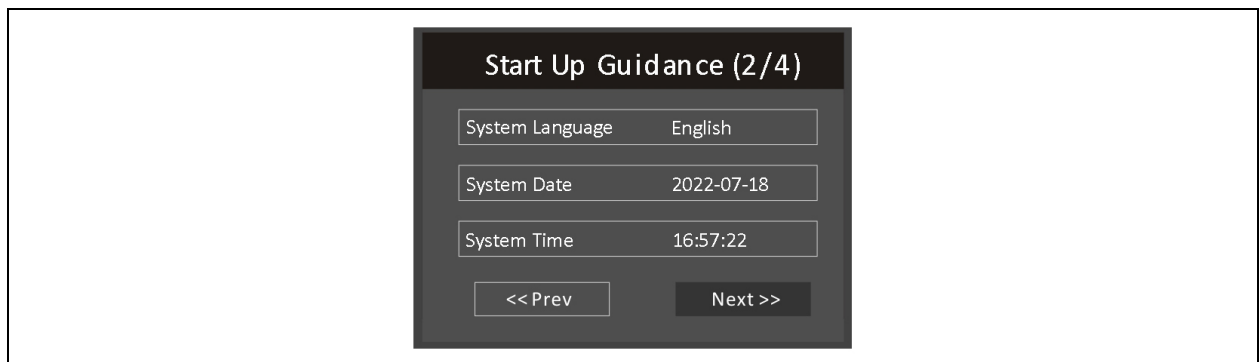

Output and battery parameters page

The parameters such as the output voltage, output frequency, and total Ah are displayed on the 'initial start-up guidance' page (These settings can be changed according to the number of batteries connected). Refer to the **Figure 5.3** below.

NOTE: The standard model can be equipped with battery modules for boost charging (up to 5, 2 by default). Compared with the long backup model, the standard backup model has a built-in battery package. If a battery module is available, the system will automatically identify the Ah of this single unit. If the external battery is connected, the built-in Ah will be added to this single unit: 7 Ah for 1 kVA, 8 Ah for 2 kVA, and 3 kVA.

Figure 5.3 Initial start-up guidance (Output and battery parameters page)

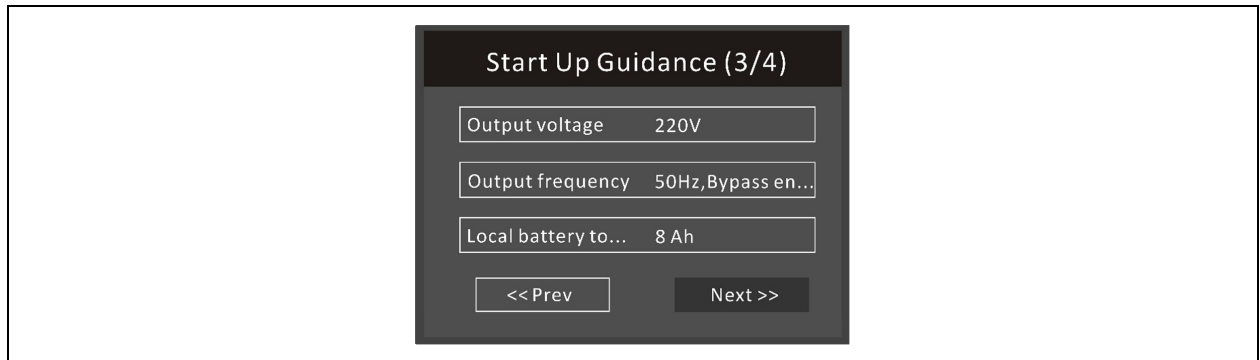

Finish page

The interface shown in **Figure 5.4** below will appear. Click Finish to enter the Flow page, then the user can operate the UPS normally.

Figure 5.4 Initial start-up guidance (Finish page)

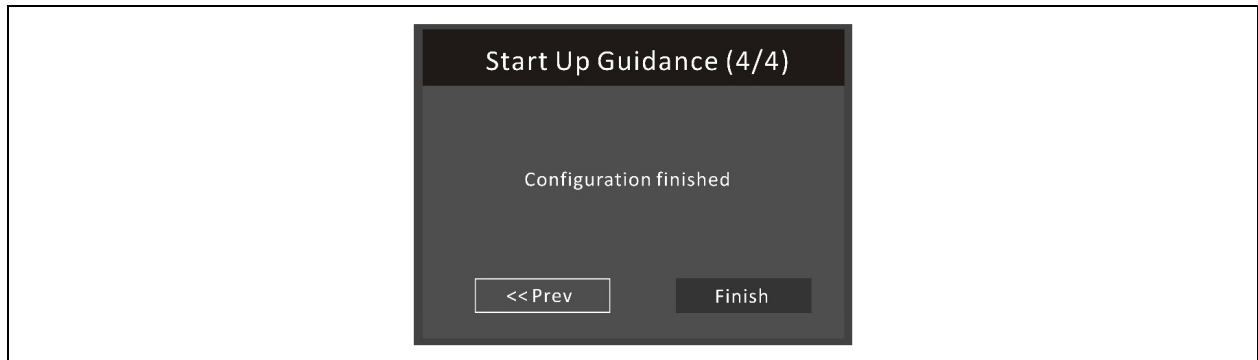

5.3 Transfer Procedures Between Operation Modes

NOTE: The Inverter operation mode includes Normal mode (mains inverter) and Battery module (battery inverter).

5.3.1 Transfer from Normal Mode to Battery Mode

The Vertiv™ Liebert® ITA2 1-3 kVA UPS will usually run in Normal mode unless the mains are disconnected; After the mains supply is disconnected, the UPS will automatically enter the battery mode. If it is necessary to switch the UPS to normal mode and restore the power supply, UPS will transfer to normal mode again.

5.3.2 Transfer from Inverter Mode to Bypass Mode

In standby mode, press and hold the power button. If the rectifier and inverter are normal, the interface shown in **Figure 5.5** below will appear, select 'YES' to turn on the UPS.

NOTE: Pressing and holding the power button will be valid only if the batteries are available.

Figure 5.5 Turning on UPS

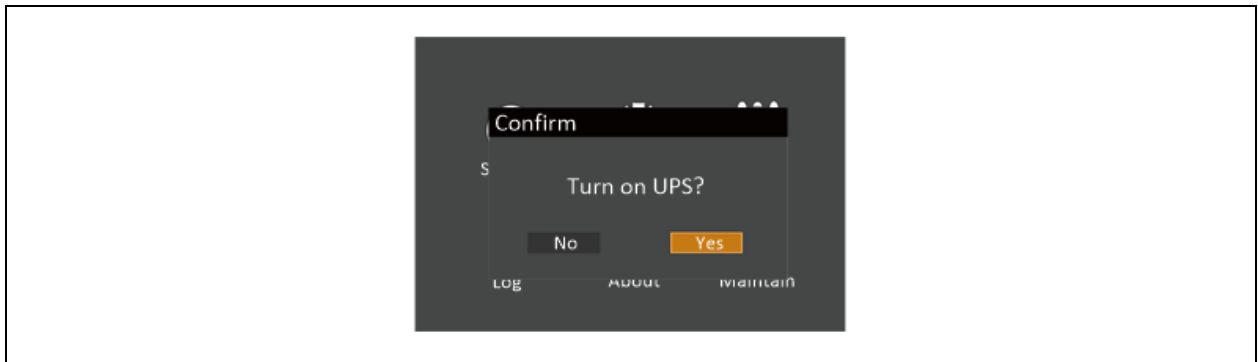

In Inverter mode, press and hold the power button. If the bypass is normal, the interface shown in **Figure 5.6** on the facing page and **Figure 5.7** on the facing page is displayed.

To transfer the UPS in Bypass mode, select "To the Bypass," and then click OK. To switch off the UPS, select "Turn off UPS," and then click OK.

Figure 5.6 Bypass normal interface (Turning on UPS/Turning off UPS)

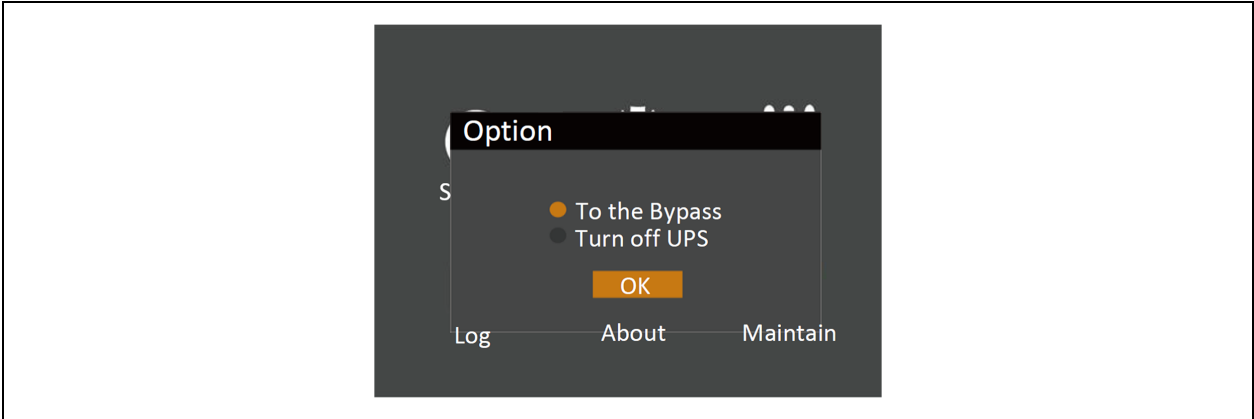

Figure 5.7 Bypass normal interface (To the Bypass)

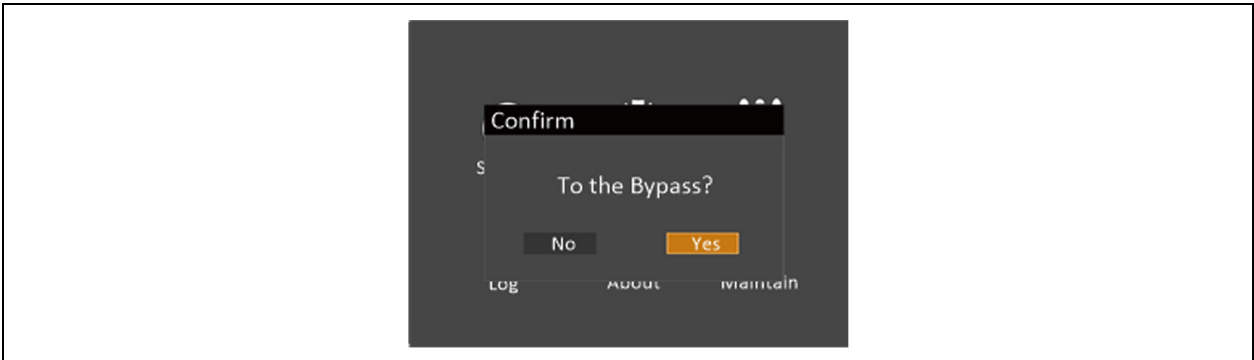
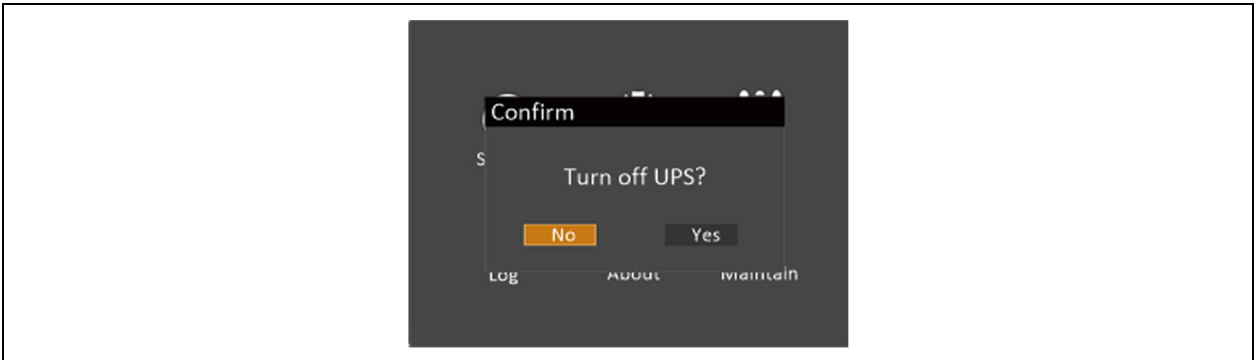
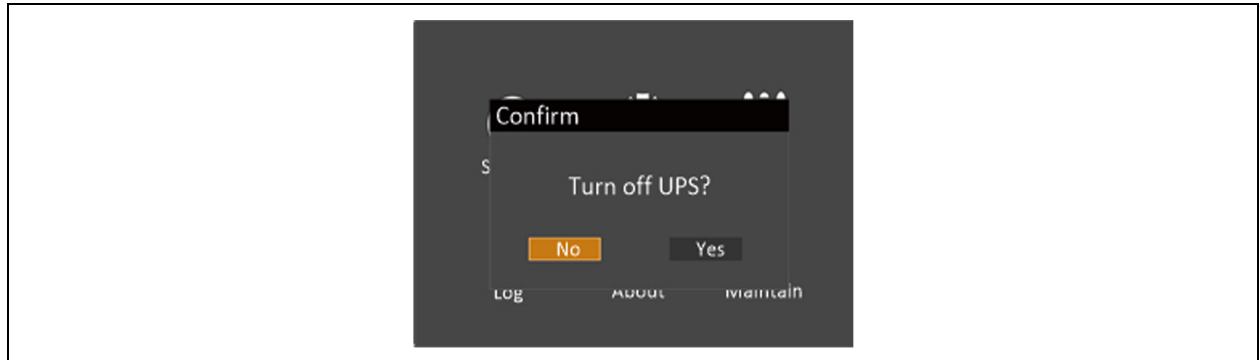

Figure 5.8 Bypass normal interface (Turn off UPS)



In Inverter mode, press and hold the power button. If the bypass is abnormal, then the interface shown in **Figure 5.9** below is displayed, select 'YES' to shut down the UPS output.

Figure 5.9 Bypass abnormal interface



NOTE: In Bypass mode, the load is directly fed by the mains power instead of the pure AC power from the inverter.

5.3.3 Transfer from Bypass Mode to Inverter Mode

In Bypass mode, press and hold the power button.

If the ECO mode is not turned on (not activated), then the interfaces shown **Figure 5.10** below, **Figure 5.11** on the facing page, and **Figure 5.12** on the facing page are displayed. Select 'Turn on UPS' and click OK to transfer to the Inverter mode, refer to the **Figure 5.13** on the facing page. Select 'Turn off UPS' and click OK to shut down the UPS output.

Figure 5.10 ECO mode not turned on (Turn on UPS/Turn off UPS)

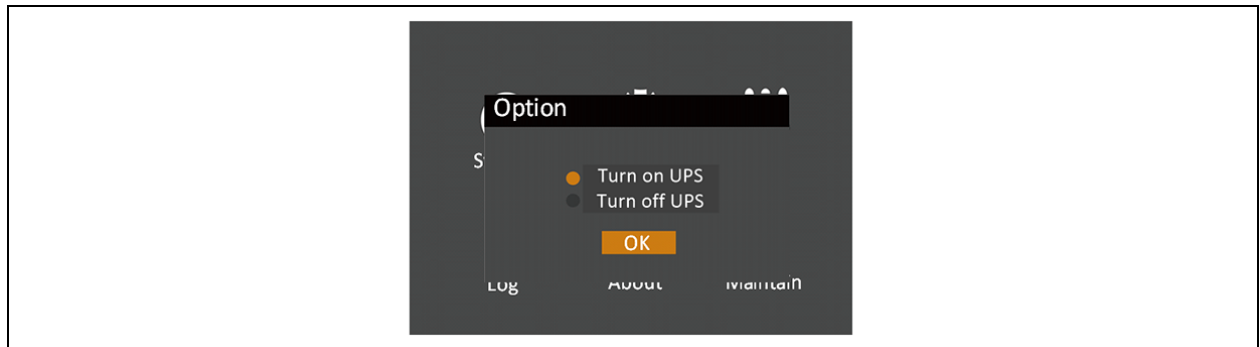

Figure 5.11 ECO mode not turned on (Turn on UPS)

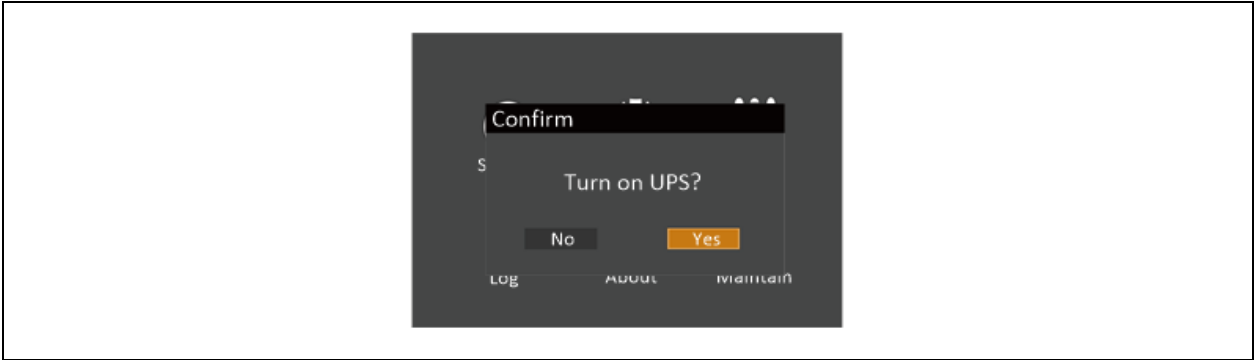
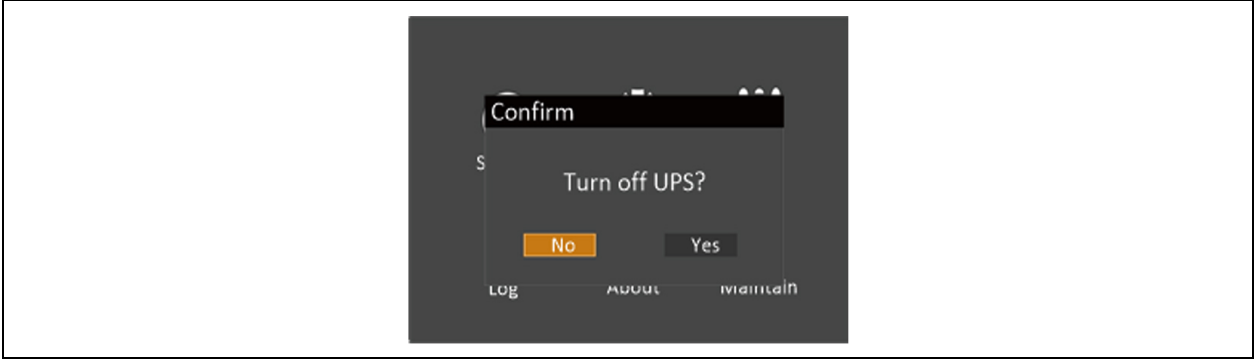

Figure 5.12 ECO mode not turned on (Turn off UPS)



If the ECO is turned on (activated), the interface shown in **Figure 5.13** below will appear. Select 'YES' to shut down the UPS output.

Figure 5.13 ECO turned on interface



5.4 UPS Complete Shutdown

For the UPS system in which the distributed power is accomplished by the user, if it is required to isolate the UPS from AC power, it is recommended to disconnect the external input MCB.

5.5 REPO

The REPO port is located at the rear of the UPS and it is designed to switch off the UPS in emergency conditions (such as fire or flood). The system will turn off the rectifier, and inverter, and stop powering the load immediately (inverter and bypass output included), and the battery stops charging or discharging. If there is of need for an emergency power-off, it is recommended to unplug the terminal connecting to the REPO port of the UPS.

The UPS control circuit will remain active if the mains input is present, but the output will be closed. The external mains input MCB must be unplugged in order to remove all mains power from the UPS.

5.6 Auto Restart

The Vertiv™ Liebert® ITA2 1-3 kVA UPS deploy the auto restart function in two conditions: with battery, and without battery.

With battery: In the case of a mains power failure, the UPS draws power from the battery to supply the load until the batteries are depleted, and then the UPS will shut down.

Without a battery, In the case of a mains power failure, while the inverter is on, the UPS will not get a power supply. The UPS will automatically restart and recover the output power supply:

- After the mains power is restored.
- The UPS Auto Restart function is enabled.
- After the Auto Restart is delayed (default: 0 s). During the Auto Restart delay, the UPS will charge the battery to provide a safety margin for equipment shutdown if input power fails again.

If the Auto Restart function is disabled, it is recommended to restart the UPS manually by pressing the power button.

5.7 Language Selection

The LCD menus are available in two languages: Chinese and English.

The procedures for selecting the preferred language are as follows:



1. On the main menu screen, press the  or  key to switch the cursor to select 'Settings', then press  key to confirm it. Refer to the **Figure 5.14** below.

Figure 5.14 Main menu (Language Selection)





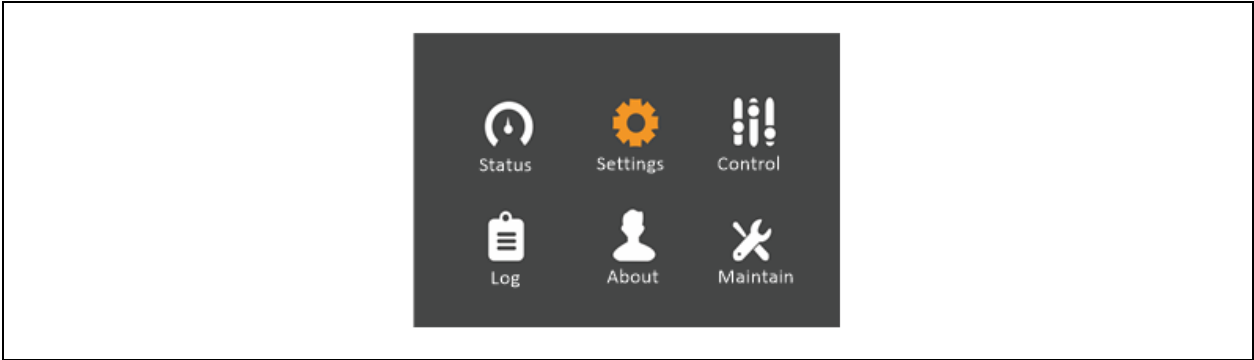
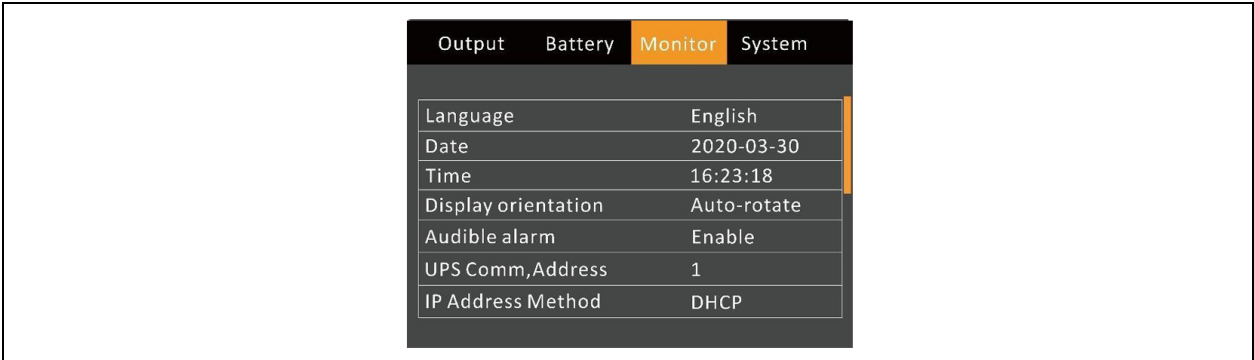

2. Press the  key to move the cursor to 'Monitor', refer to **Figure 5.15** below.

Figure 5.15 Monitor interface

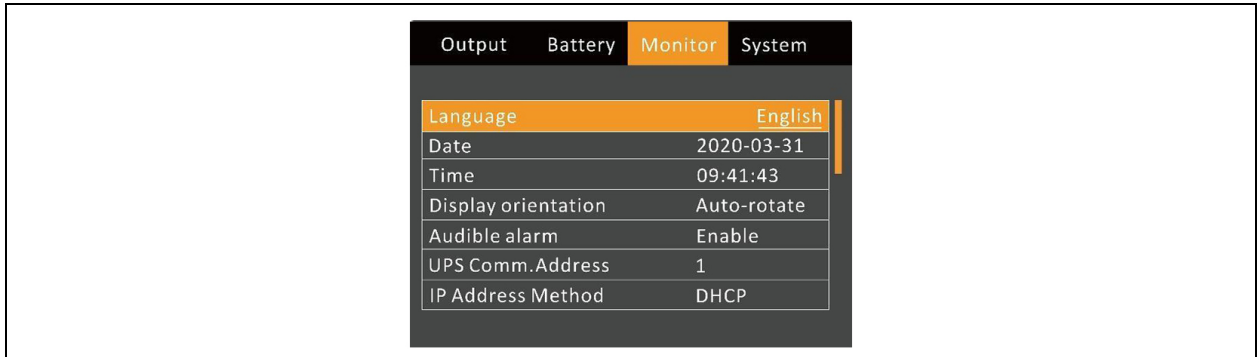

3. Press the  key to highlight the language, refer to **Figure 5.16** below.

Figure 5.16 (Monitor) Language selection

4. Press the  or  key to select the preferred language, then press  key to confirm it. The LCD contents will be the language selected.
5. Press the  key several times to return to the main menu screen.

5.8 Changing Current Date and Time

The following procedures are required to change the system date and time:



1. On the main menu screen, press the  or  key to switch the cursor to select 'Settings', then press  key to confirm it. refer to the **Figure 5.17** below.

Figure 5.17 Main menu screen



2. Press the  key to move the cursor to 'Monitor', refer to **Figure 5.18** below.

Figure 5.18 Monitor interface (Changing Current Date and Time)



3. Press the  key and then press the  or  key to highlight the date and time, refer to **Figure 5.19** below and **Figure 5.20** below.

Figure 5.19 Selection of date and time (Changing Current Date).

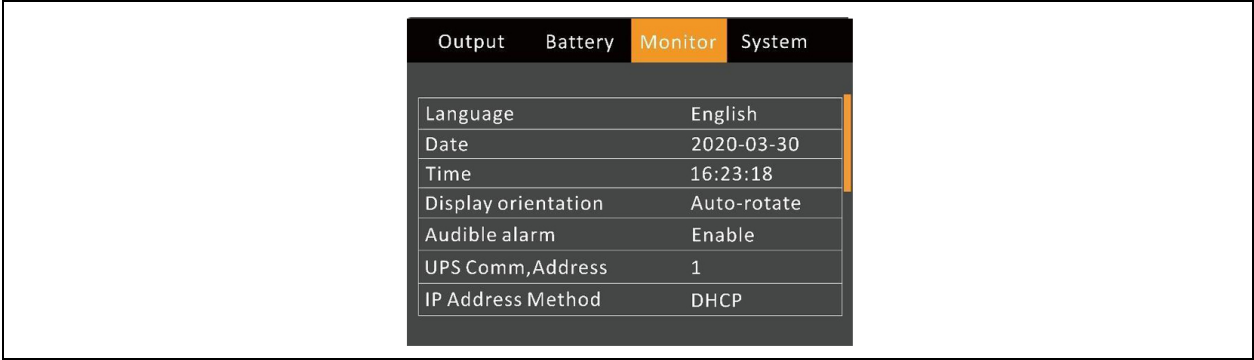
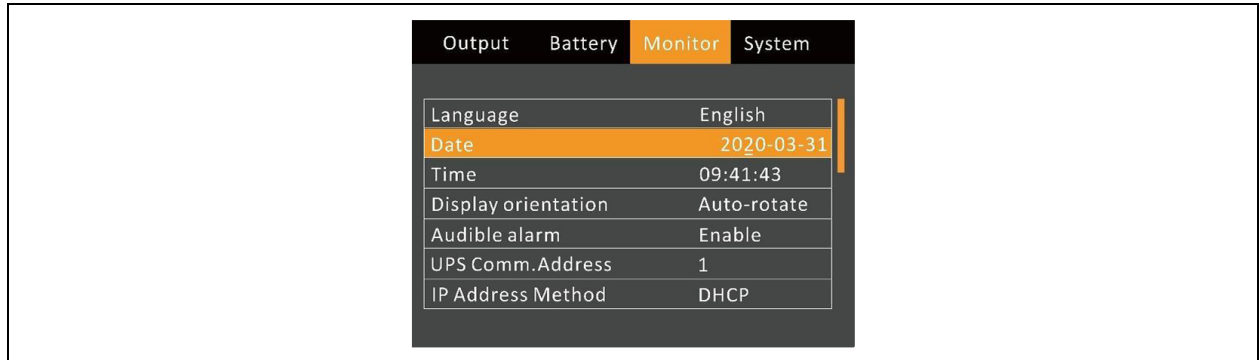
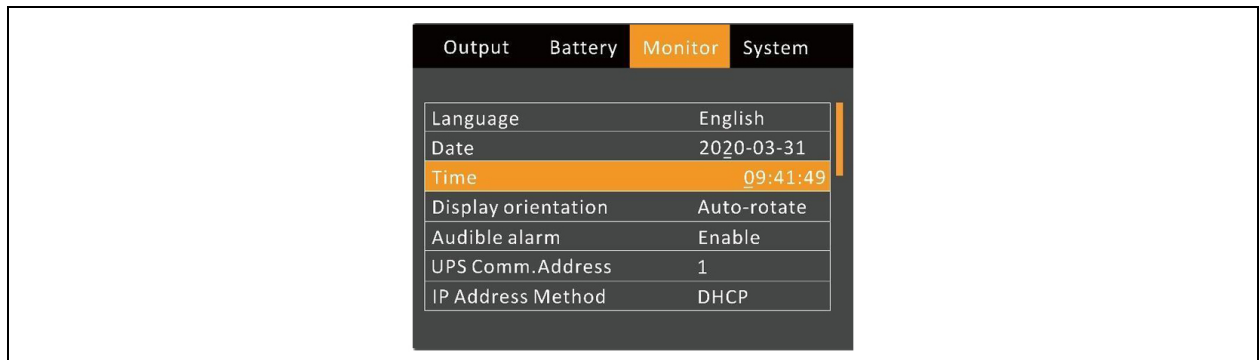







Figure 5.20 Selection of date and time (Changing Current Time)



4. Press the  key, move the cursor, and press  or  key to change or set the preferred date and time.
5. Press the  key to confirm it, and then press the  key several times to return to the main menu screen.

5.9 Setting Password

The default password for the Settings page is 111111. It is a must to enter the current password first, and then change it to the preferred password. However, it is recommended to set the password to the default value to protect your system and devices. If the default password is changed, record the new password, and save it in an accessible location for later retrieval.

If it is required to change the password on the setting page, please follow the steps below:



1. After switching on the UPS, press the  or  key to move the cursor to select 'Settings' on the main menu screen. Refer to the **Figure 5.21** below.

Figure 5.21 Main menu (Settings)



2. Press the  key, and then the interface shown in **Figure 5.22** below is displayed.

Figure 5.22 Inputting password

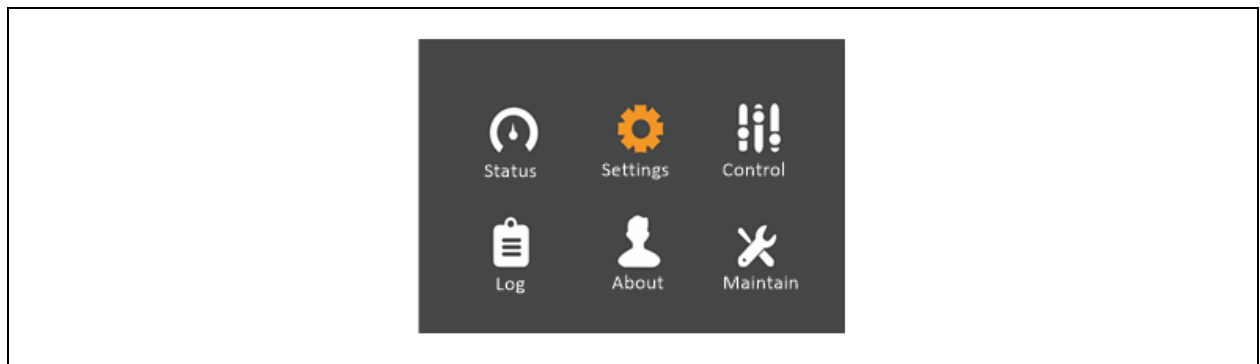
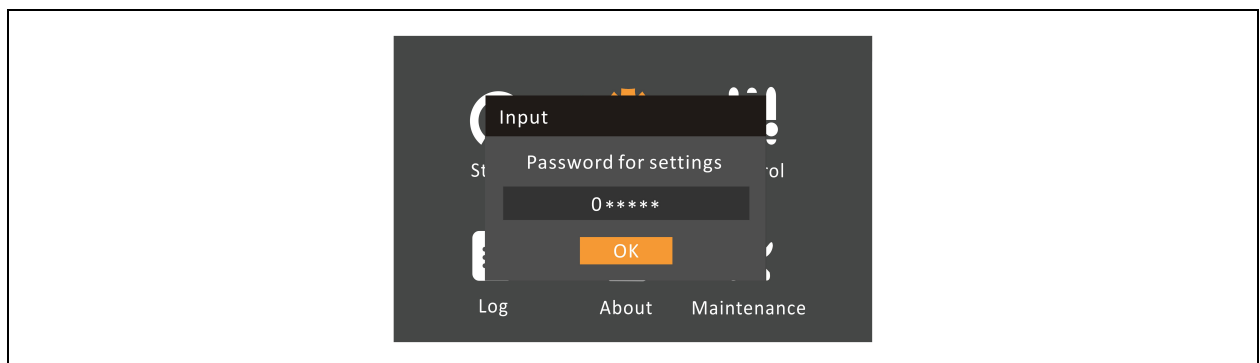

The user can observe the following procedures to change password:

1. Press the  key to move the cursor to the 'Monitor', refer to the **Figure 5.23** below.

Figure 5.23 Monitor interface (Setting password)



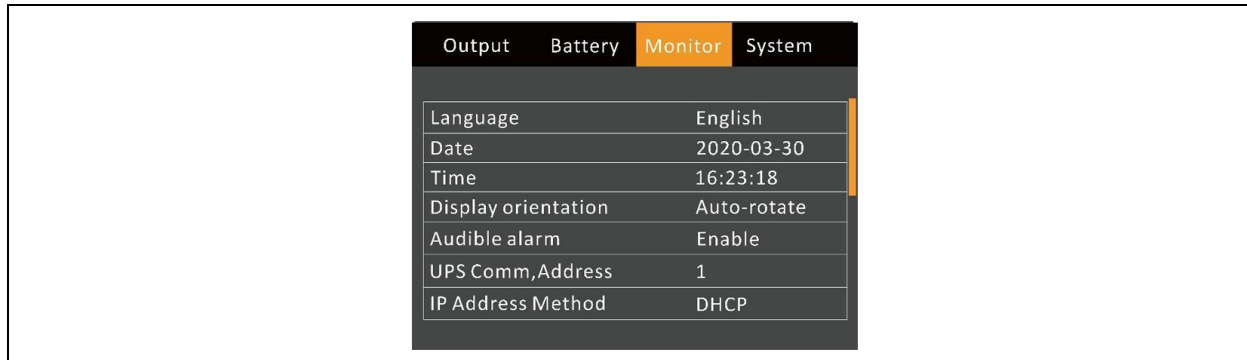

2. Press the  key, then press the  key to select the 'Change settings password', refer to **Figure 5.24** below.

Figure 5.24 Monitor (Changing settings password)



- 3. Press the  key, then the interface shown in **Figure 5.25** below is displayed.

Figure 5.25 Password for settings

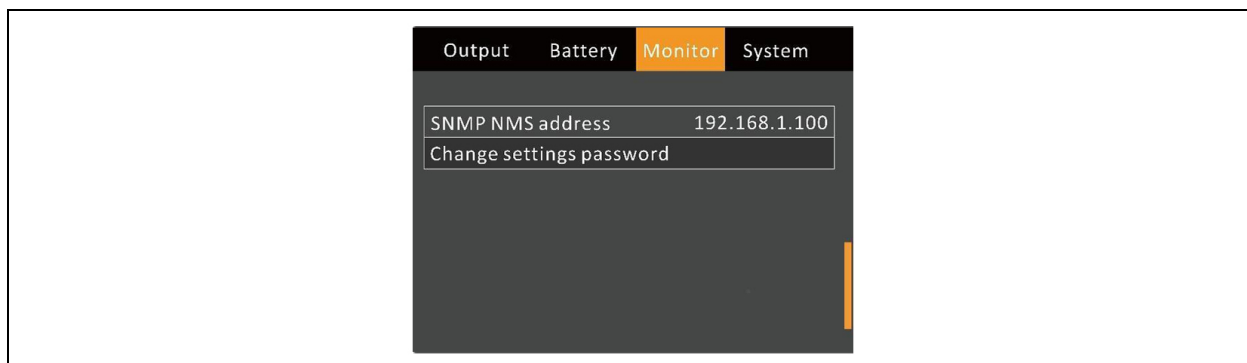

- 4. Input the existing password, then press  key to confirm it, and then it is required to input a new password into the system. Refer to **Figure 5.26** below.

Figure 5.26 Inputting new password

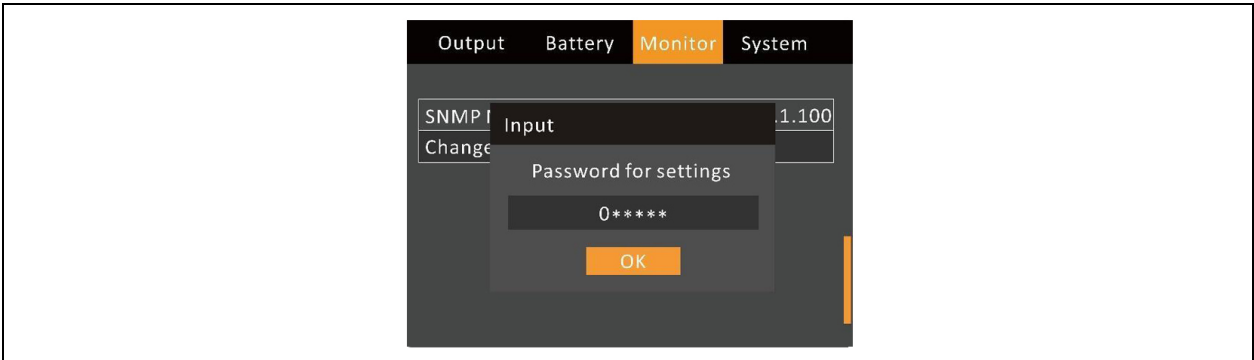

5. After inputting the new password, press **Enter** key to confirm it, then the interface shown in the **Figure 5.27** below is displayed. It is required to confirm the new password in the system.

Figure 5.27 Confirming new password

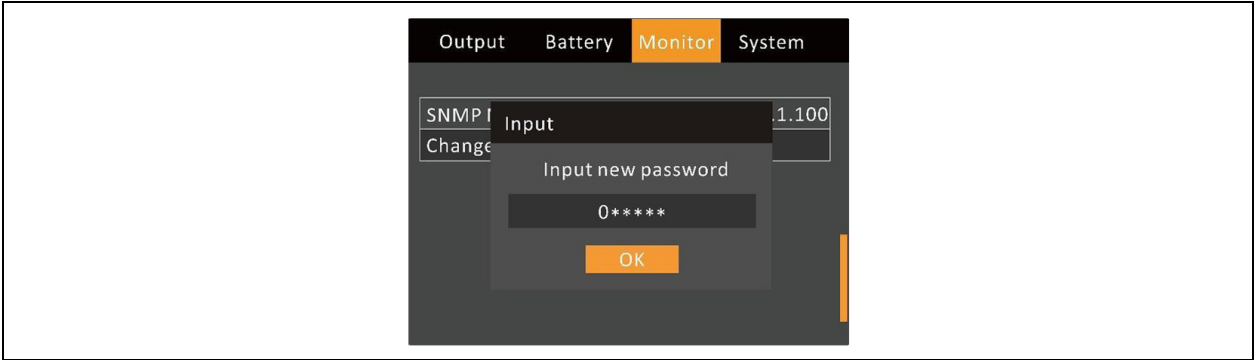
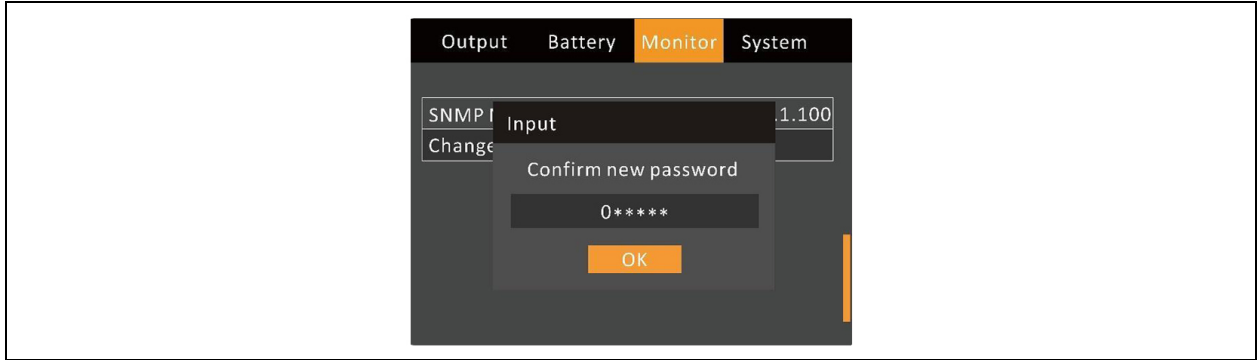

6. After the confirmation, press the **Enter** key and the system prompts that the password is successfully changed, refer to the **Figure 5.28** below.

Figure 5.28 Password changed OK

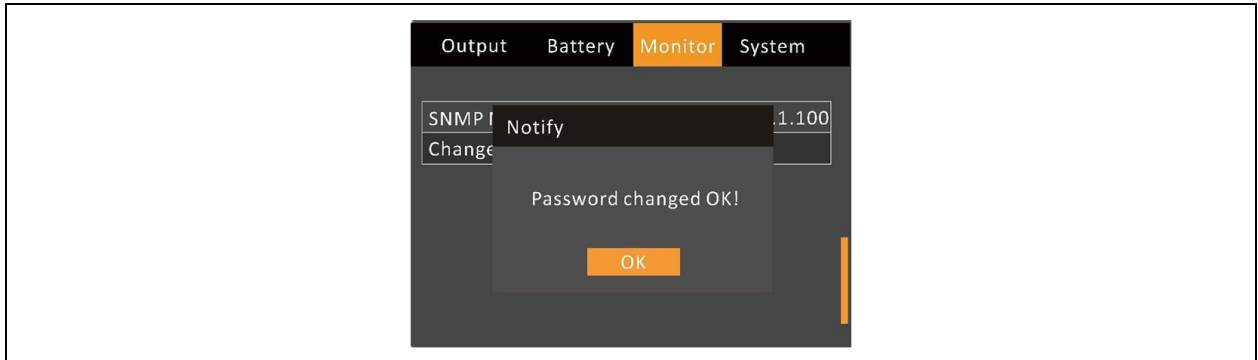

7. Press the **Esc** key several times to return to the main menu screen.

NOTE: The UPS parameters can be confirmed only after verifying the correct password (default password : 11111).

6 Operation and Display Panel

This chapter describes the functions and use of the components on the UPS operation and display panel and provides LCD display information, including the LCD screen types, detailed menu messages, prompt windows messages and UPS alarm list.

6.1 Introduction

The display panel is located on the front panel of the UPS. It is possible to operate and monitor the UPS through the display panel. It is also possible to view the UPS parameter settings, UPS and battery status information, and any alarm messages.

The display panel includes an LCD screen, menu keys, and LED indicators (run indicator and alarm indication), as shown in **Figure 6.1** below and **Figure 6.2** on the next page.

Figure 6.1 Operation and display panel (1)



Figure 6.2 Operation and display panel (2)



Parameter	Description
1	Menu keys
2	LCD
3	Run indicator
4	Alarm indicator
5	Power button

NOTE: The device has a gravity sensor function; thus the LCD display direction will be changed according to the device layout mode.

6.1.1 LED Indicators

The LED indicators consist of the run indicator and alarm indicator. **Table 6.1** below describes these indicators.

Table 6.1 Description of LED indicators

Indicator	Color	State	Meaning
Run indicator	Green	On	UPS has output
		Blinking	Inverter is starting
		Off	UPS has no output, inverter is starting
Alarm indicator	Yellow	On	Alarm occurs
	Red	On	Fault occurs
	/	Off	No alarm, no fault

6.1.2 Audible Alarm (Buzzer)

The UPS operation is accompanied by two different types of audible alarms shown **Table 6.2** below.

Table 6.2 Description of audible alarm

Alarm Type	Meaning
Continuous beep	Alarm is generated when the UPS fault appears, such as fuse or hardware failure
One beep every 0.5 second	Alarm is generated when the UPS critical alarm appears, such as Inverter overload
One beep every second	Alarm is generated when the UPS critical alarm appears, such as battery low voltage
One beep every 3.3 second	Alarm is generated when the UPS general alarm appears

6.1.3 LCD and Functional Keys

The operation and display panel includes five functional keys, the respective functions are described in **Table 6.3** below.

Table 6.3 Description of control buttons





Functional key	Silk print	Description
Confirm		Used to confirm or enter
Up		Used to page up, turn left or add value.
Down		Used to page down, turn right or reduce value.
Escape		Used to back, escape, cancel or forbid operation
Power		Used to power on, power off or transfer to Bypass mode

Figure 6.3 LCD screen



Parameter	Description
1	ECO mode
2	Ambient temperature and Ambient humidity (Displayed only when the sensors are connected)
3	Date and time

The LCD screen provides a user-friendly interface. The user-friendly and menu-driven LCD allows you to easily browse through the parameters such as UPS input, UPS output, load parameters, and battery parameters, learn about the current UPS status and alarm message, perform functional settings, and control operation. The LCD also stores historical alarm records that can be retrieved for reference and diagnosis.

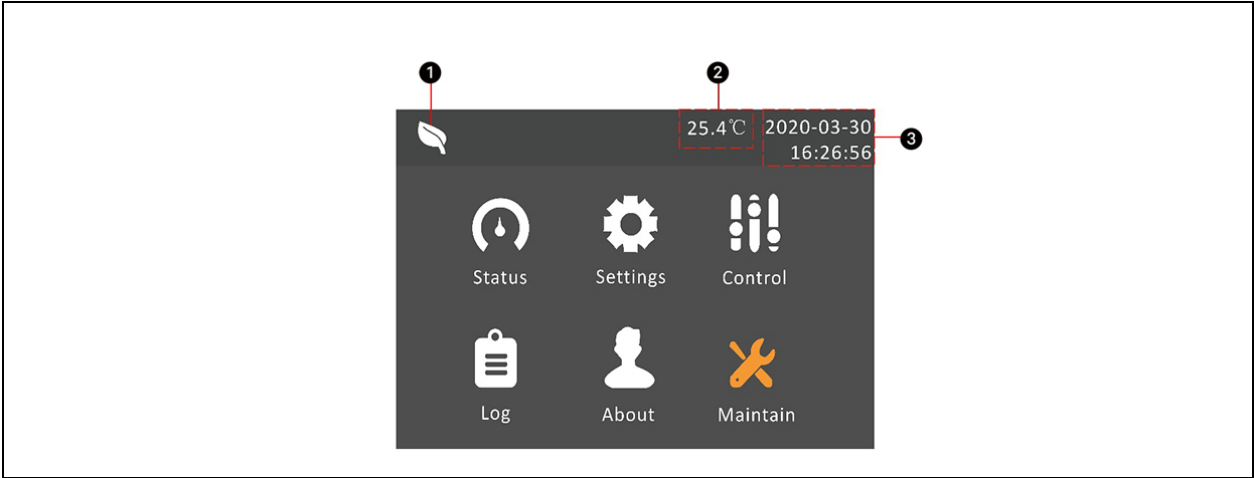
6.2 LCD Menu Structure

Figure 6.4 LCD menu structure

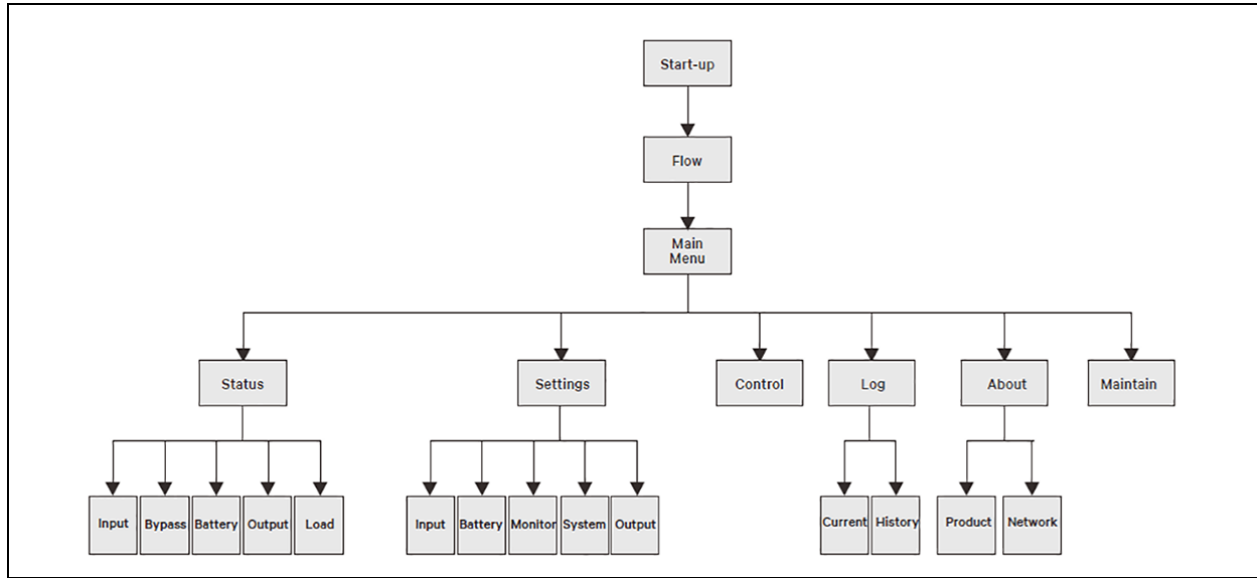

6.3 LCD Screen Types

6.3.1 Start Screen

Upon UPS start-up, the UPS executes the system self-test, and the start screen is displayed and remains for approximately 10 seconds, as shown in Figure 6.5 below.

Figure 6.5 Start screen

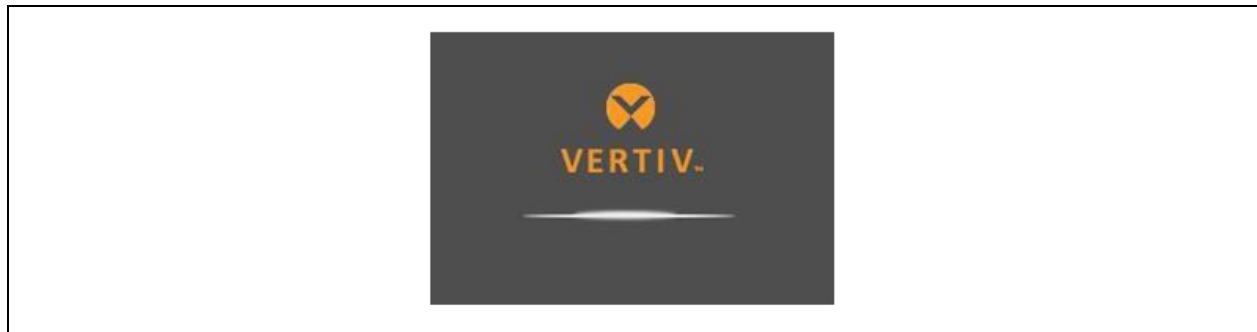

6.3.2 Flow Screen

After the completion of the self-test of the UPS, the flow screen is displayed as shown in **Figure 6.6** below.

The flow screen displays the total status view of the UPS. The parameters displayed on the flow screen include input, bypass, rectifier, battery, inverter, and output.

The working modes appear with a colored display while the invalid modes appear with a gray display.

Figure 6.6 Flow screen

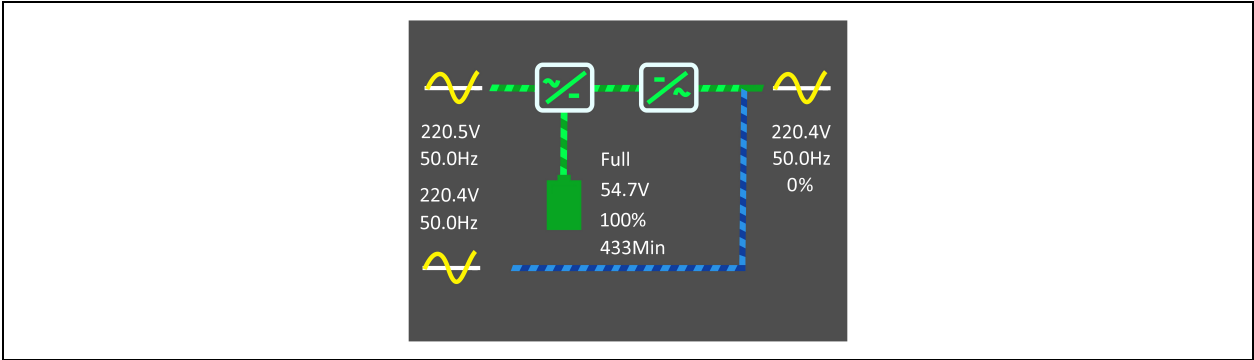





On the flow page, press the  key to enter to the primary screen.

6.3.3 Main Menu Screen

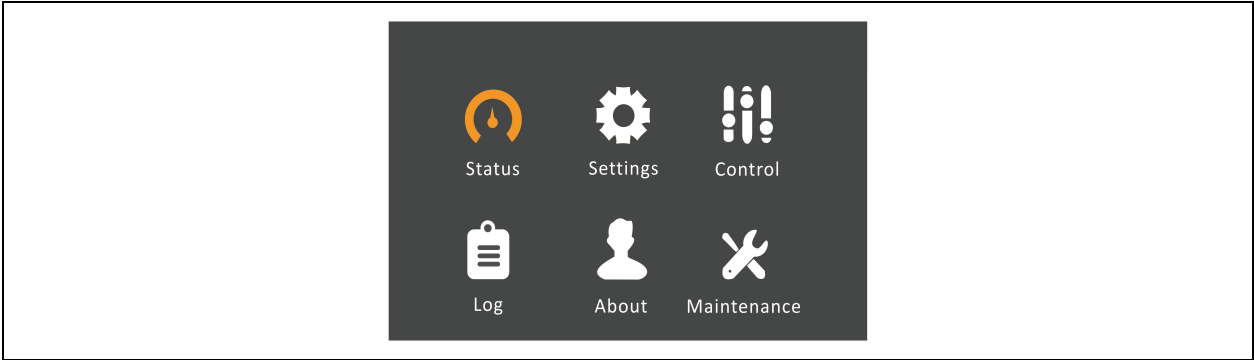
The main menu screen displays six icons: Status, Settings, Control, Log, About, and Maintain; as shown in **Figure 6.7** below.

Figure 6.7 Main menu screen (Status)



On main menu screen, press the  key to return to the flow screen. Press the  or  key to switch the cursor to select the submenu you need, then press  key to confirm it.

6.3.4 Submenu Screen

The submenu screen contains the UPS parameters and item settings.

After entering the submenu screen, if there is a tab control, just move the cursor to the tab. At this time,

press the  or  key to switch the tab. Press  the key to move the cursor to a certain item.

After entering the submenu screen, if there is no tab control, then the cursor will stop at a certain Item.

Press the  key to return to the previous screen.

For details about the submenu screen, refer to the following pages.

Status page

The main menu screen (Status page) displays five icons: Input, Bypass, Battery, Output, and Load. Refer to the following images from **Figure 6.8** below to **Figure 6.13** on page 70.

Figure 6.8 Main menu screen (Status page)

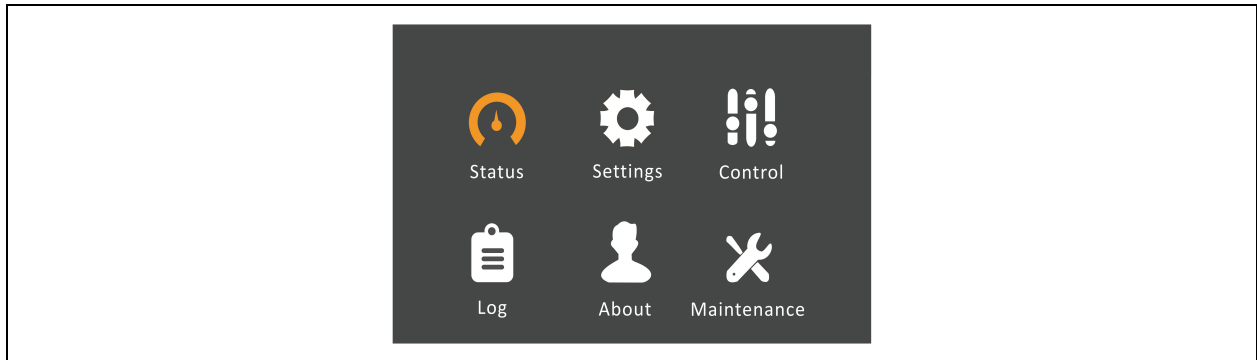

Figure 6.9 Status page (Input)

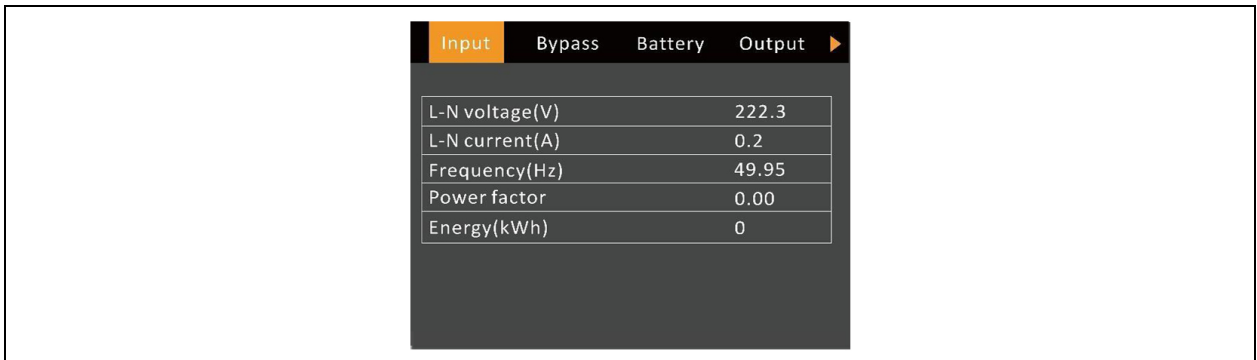

Figure 6.10 Status page (Bypass)

Input	Bypass	Battery	Output
L-N voltage(V)	221.9		
Frequency(Hz)	49.95		

Figure 6.11 Status page (Battery)

Input	Bypass	Battery	Output
Battery status		FloatChg	
Battery voltage(V)		40.8	
Battery current(A)		0.06	
Backup time(Minutes)		426.4	
Remaining capacity(%)		90	
External battery cabinet gro...		0	
Battery replaced time		2000-01...	

Figure 6.12 Status page (Output)

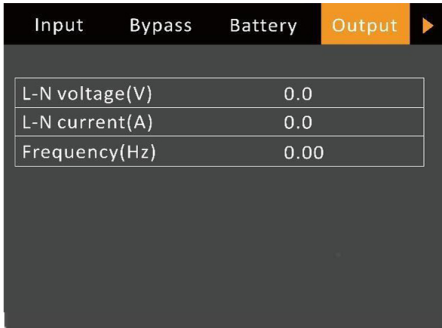

The screenshot shows a dark-themed interface with a top navigation bar containing 'Input', 'Bypass', 'Battery', and 'Output' (highlighted in orange with a right-pointing arrow). Below the navigation bar is a table with three rows of data.

L-N voltage(V)	0.0
L-N current(A)	0.0
Frequency(Hz)	0.00

Figure 6.13 Status page (Load)

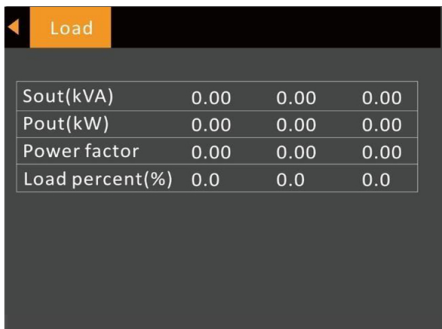

The screenshot shows a dark-themed interface with a top navigation bar containing 'Load' (highlighted in orange with a left-pointing arrow). Below the navigation bar is a table with four rows of data.

Sout(kVA)	0.00	0.00	0.00
Pout(kW)	0.00	0.00	0.00
Power factor	0.00	0.00	0.00
Load percent(%)	0.0	0.0	0.0

Settings page

The Settings page contains the Output, Battery, Parallel, Monitor, System, and Outlet. For details about the parameters setting, refer to the section Appendix A [LCD Parameters Setting](#) on page i .

Refer to the images from **Figure 6.14** below to **Figure 6.22** on page 73.

Figure 6.14 Monitor menu screen (Settings page)

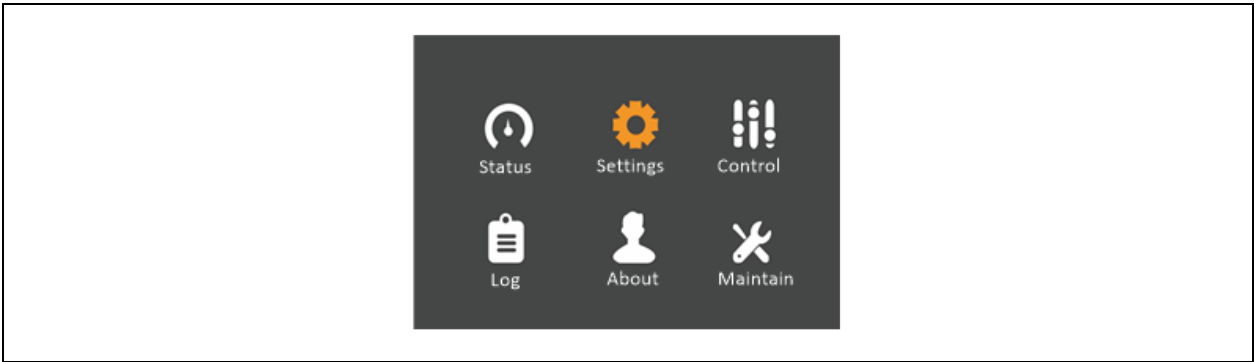

Figure 6.15 Settings page (Output)

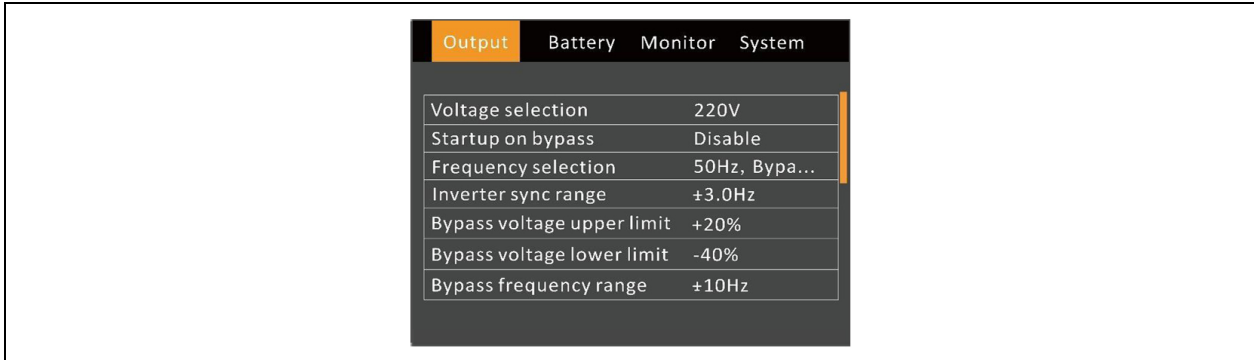

Figure 6.16 Settings page (Output) Run mode

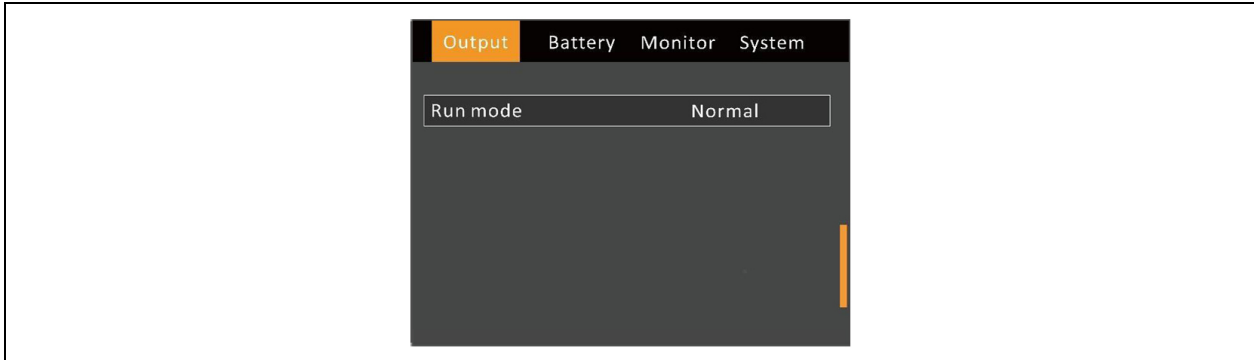

Figure 6.17 Settings page (Battery)

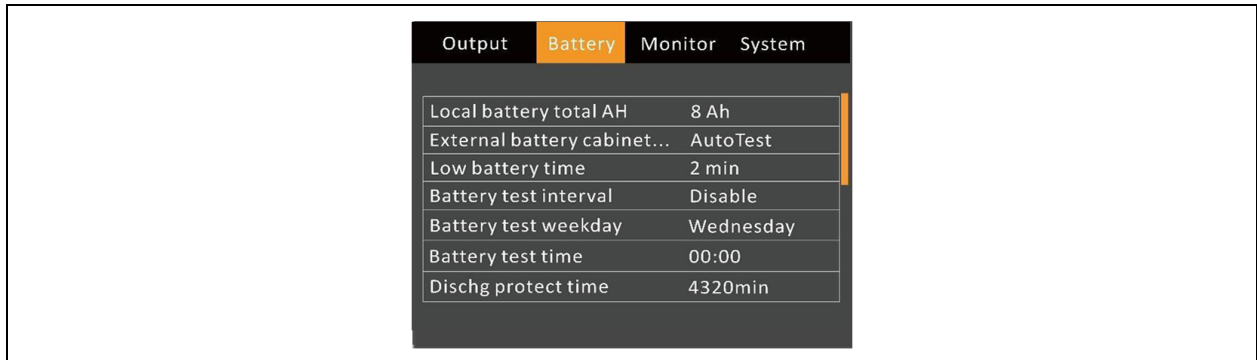

Figure 6.18 Settings page (Battery) (Scrolled)

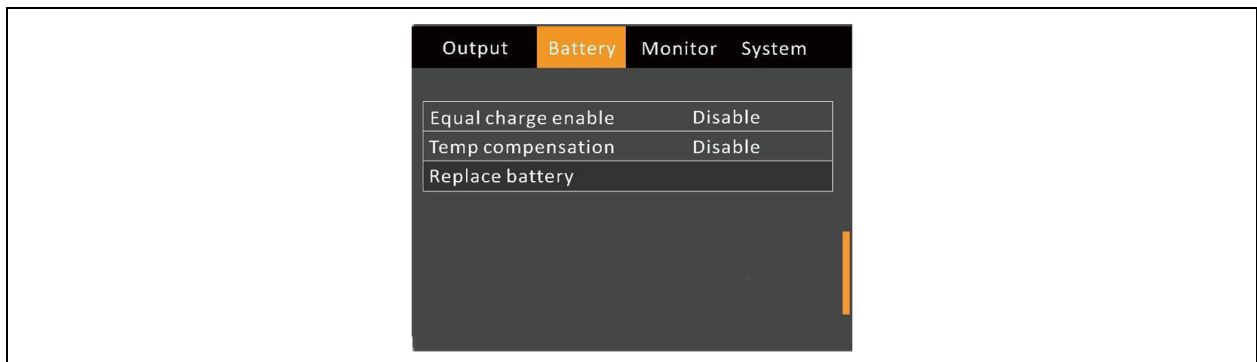

Figure 6.19 Monitor (Settings page)

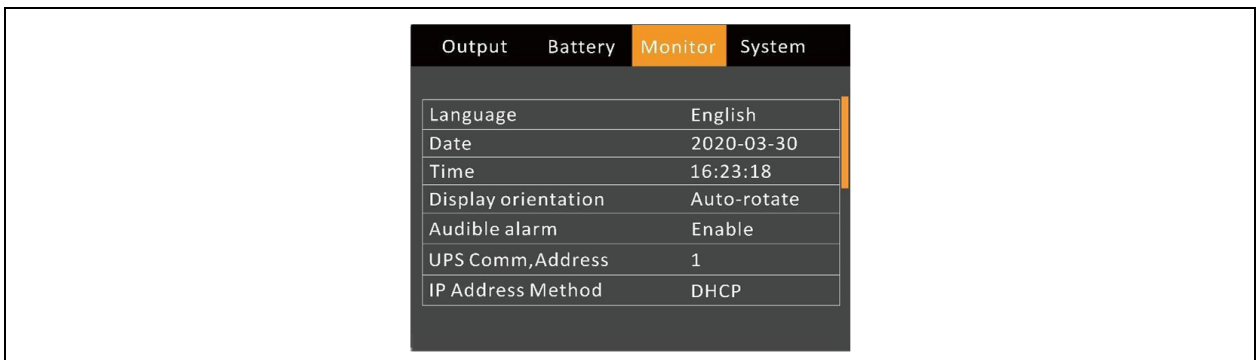

Figure 6.20 Monitor (Settings page) (Scrolled)

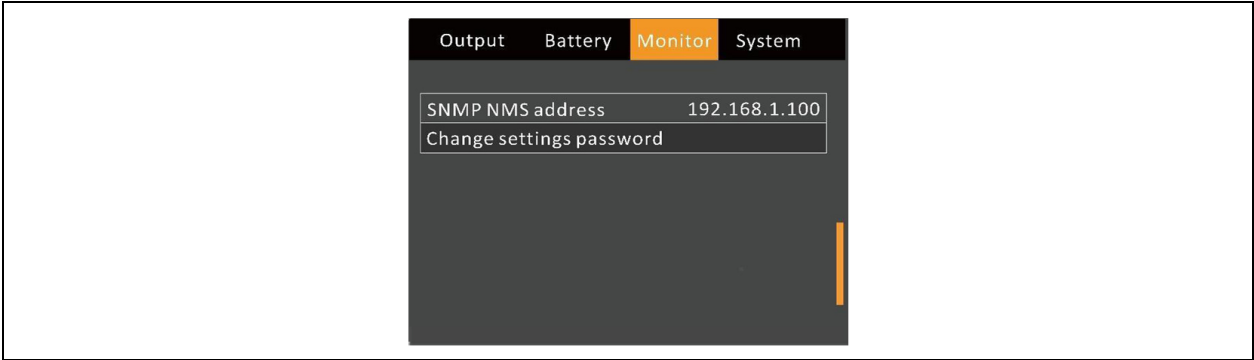

Figure 6.21 Settings page (System)

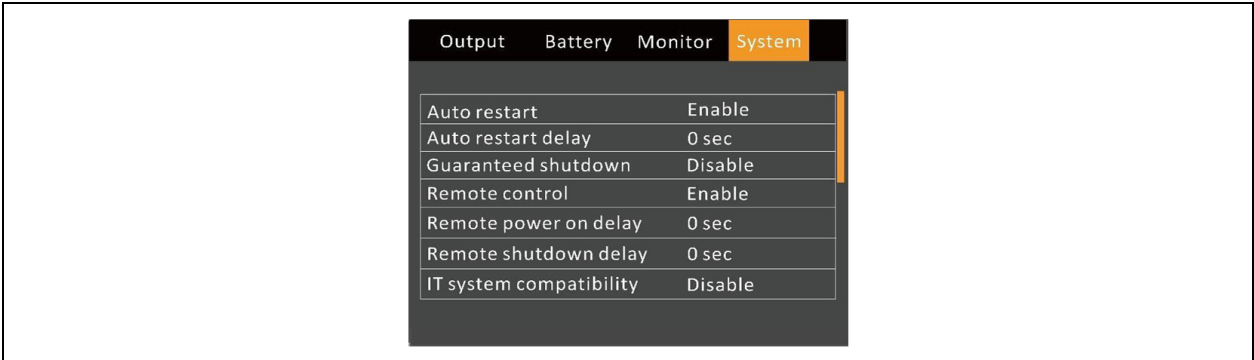
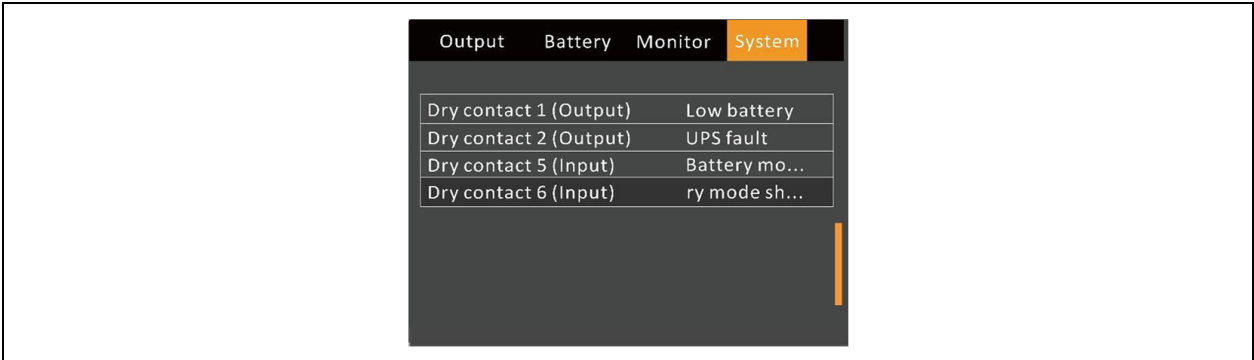

Figure 6.22 Settings page (System) (Scrolled)



Control page

Figure 6.23 Control page (Monitor)

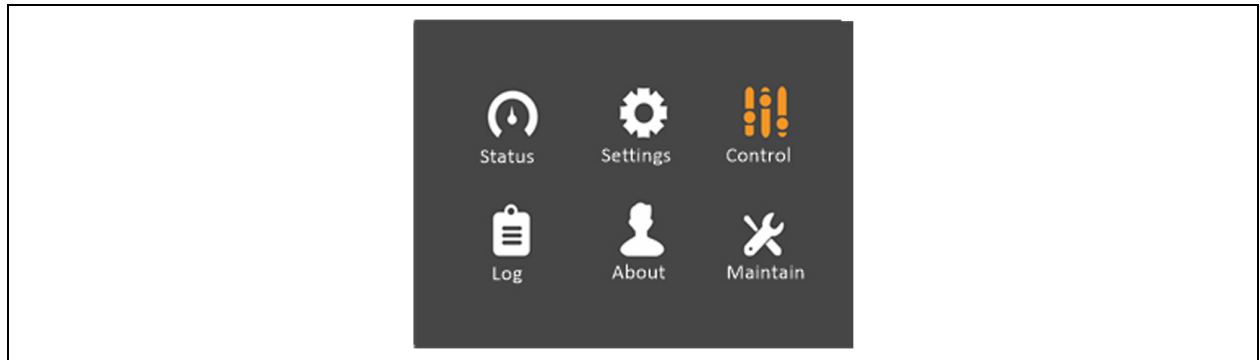
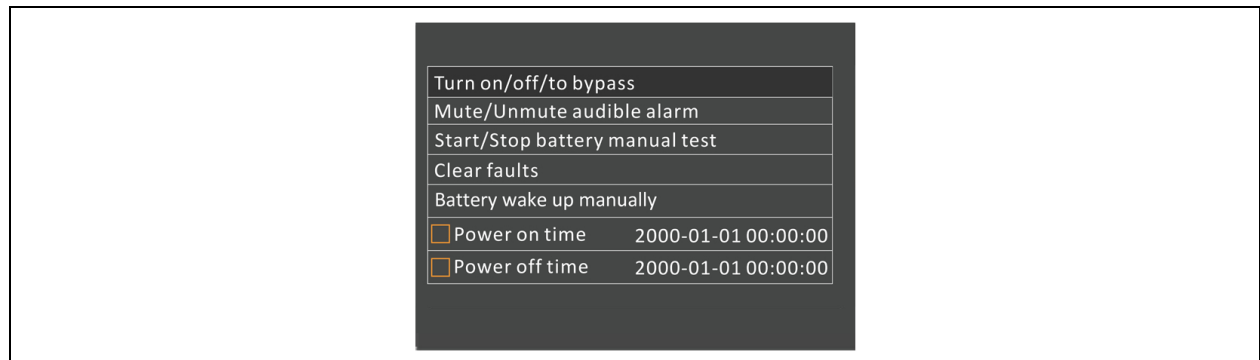

Figure 6.24 Control page (Turn ON/OFF/to BYPASS)



The Control page contains the Turn ON/OFF/to BYPASS, and Manual battery test. Refer to the in **Figure 6.24** above.

Log page

The Log page contains the Current and History. Refer to the image **Figure 6.25** below to **Figure 6.26** below.

Figure 6.25 Log page (Monitor)

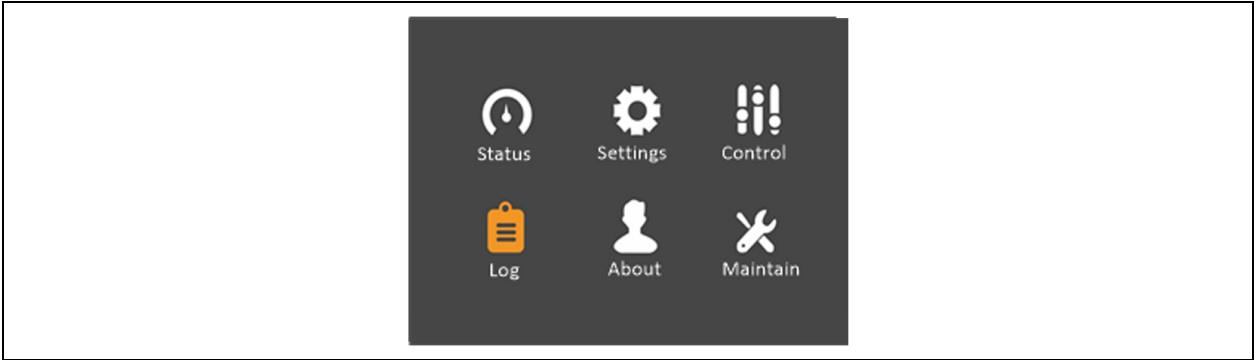
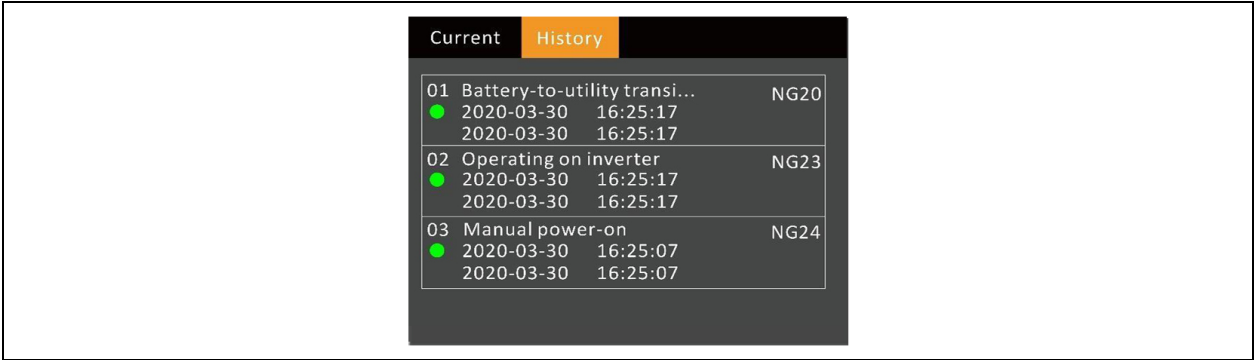

Figure 6.26 Log page (History)



About page

The About page contains the Product and Network. Refer to the images from **Figure 6.27** below to **Figure 6.30** on the facing page.

Figure 6.27 About page (Monitor menu screen)

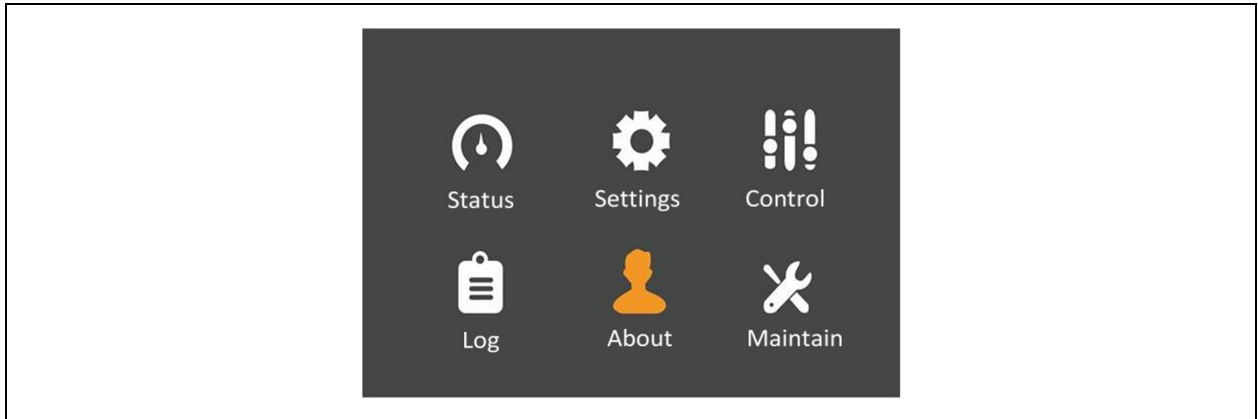

Figure 6.28 About page (Product)

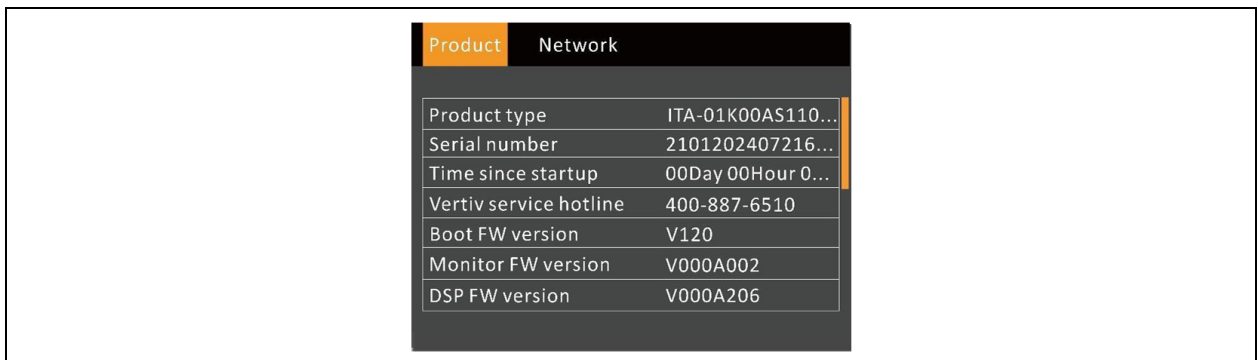

Figure 6.29 About page (Product) (Scrolled)

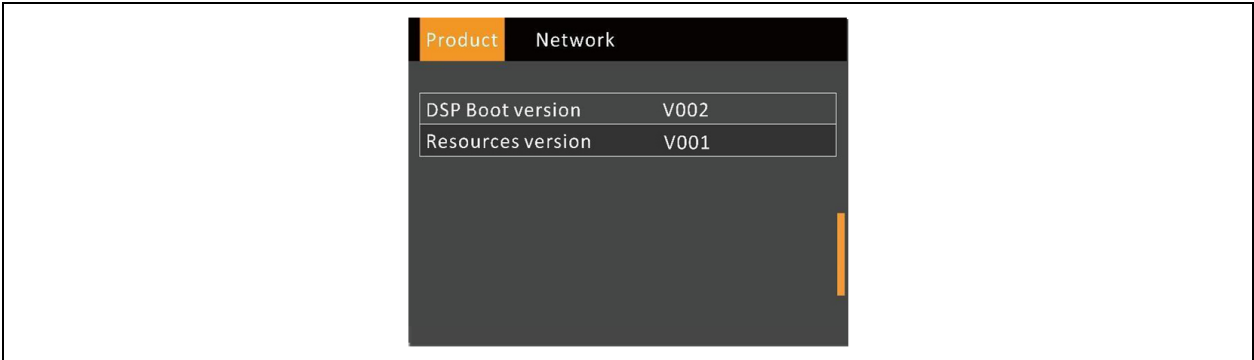
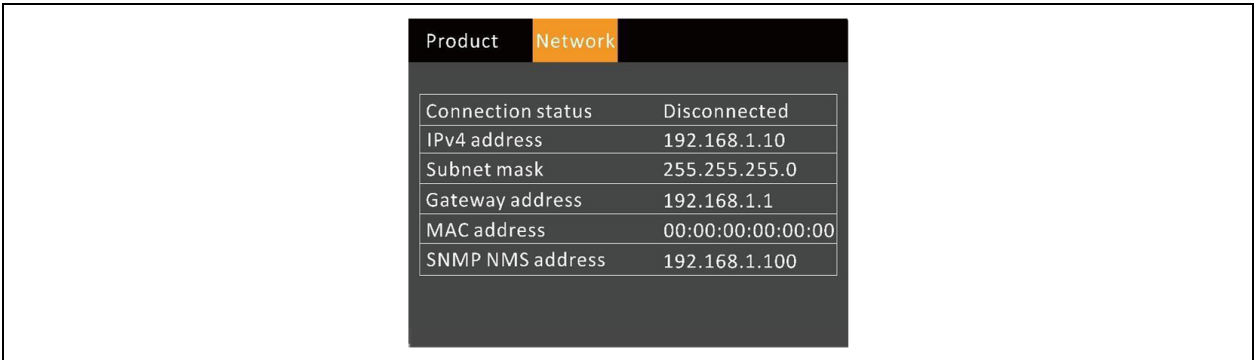

Figure 6.30 About page (Network)



Maintain page

NOTE: The Maintain page is only accessible to Vertiv service engineers and it is required to enter the correct password to proceed with th maintenance operation.

6.3.5 Default Screen

During the UPS operation, if there is no alarm within two minutes, the default screen shown in **Figure 6.31** below will appear. On the default screen, if there is an alarm or a fault, or the user press any key, the Flow screen will appear again.

Figure 6.31 Default screen



6.4 Prompt Window

A prompt window is displayed during the operation of the system to alert the user to certain conditions and/or to request the user's confirmation of a command or other operation. The prompts and their meanings are listed in **Table 6.4** below.

Table 6.4 Prompts and meanings

Prompt	Meaning
Cannot set this online, please shut down output	The prompt is displayed if the user wants to change some important settings under the condition of output (output voltage, output frequency, and output phase No.)
Incorrect password, please input again	The prompt is displayed when the user incorrectly input the settings Password
Operation failed; condition is not met	The prompt is displayed when the user wants to execute a certain operation but the condition is not met
Password changed OK	The prompt is displayed when the user successfully changes the settings Password
Fail to change password, please try again	The prompt is displayed when the user tries to change the Settings password but input two different new passwords
The time cannot be earlier than system time	The prompt is displayed when the user sets the 'Turn on delay' or 'Turn off delay' time which is earlier than the 'current system time'.
Turn on failed, condition is not met	The prompt is displayed when the user press the power button (or execute the command of 'Turn on/Turn off/to Bypass' under 'Control' page).

6.5 List of UPS Alarm and Fault Message

Table 6.5 below gives all UPS alarm and fault messages based on the 'Current' and 'History' menus.

Table 6.5 UPS alarm message list

Alarm message	Description Test result
Input abnormal	The rectifier and charger are off due to the mains voltage and frequency exceeding normal range. Check that the rectifier input phase voltage and frequency exceed the normal range or that the mains have power-off.
Fan fault	The fan is faulty. Check that the fan is blocked, the speed is zero, or the cable connection is loosened.
Rectifier overload	The output power is greater than the rectifier overload point. Check that the input voltage meets the output load, mains input 176 V to 100 V, the load 100% to 50% linear derating.
Inverter on failed	Check the input voltage, frequency, and system settings
Rectifier fault	The rectifier is faulty and off .
Charger fault	The charger output voltage is abnormal and the charger is off
DC/DC fault	The discharger is faulty, because the bus voltage exceeds the setting range when discharger starts or soft
System overtemp	The internal heat sink temperature is too high, and the inverter is off. Only with each module heat sink temperature decreased to the setting value can you silence the alarm. The system can automatically start after an over-temperature fault is solved. If over-temperature, please check the following points: <ol style="list-style-type: none"> 1. Ambient temperature is too high or not 2. Dust is blocked or not 3. Fan is faulty or not
Inverter overload	The Inverter load capacity is greater than the rated value, the overload delay time is up, and the inverter shuts down. If a bypass is available, the system will transfer to the bypass mode, otherwise, the output failure occurs. Check the actual inverter load capacity, if overloaded, just reduce the load capacity, and the system will transfer to the inverter mode after five minutes and the alarm is cleared.
Inverter fault	The inverter is turned off when the inverter output voltage and current exceed the set range. If a bypass is available, the UPS will transfer to bypass mode, otherwise, the system will power off.
Output pending	Remote shutdown is enabled, and then the system will be switched off
Output disabled	The system is in the standby state, and the dry contact shutdown is enabled. Check whether the shutdown dry contact is enabled or not
Battery module connection abnormal	If the number of battery cabinets detected exceeds 6, report any abnormal connection of battery modules.
DC bus abnormal	The inverter is off when the DC bus voltage is faulty. The load will be transferred to the bypass if the bypass is available
Bypass overcurrent	The bypass current exceeds the rated value. The overload delay time is up, the inverter shuts down.

Table 6.5 UPS alarm message list (continued)

Alarm message	Description Test result
Bypass abnormal	Maybe caused by bypass voltage and bypass frequency are exceeding the configured range, bypass power-off and incorrect bypass cables connection. 1. Check that the bypass voltage and bypass frequency are within the configured setting range. 2. Check the bypass cables connection.
Bypass abnormal in ECO mode	The ECO mode is available, and the bypass voltage and bypass frequency are exceeding the configured setting range. Check that the bypass input voltage and bypass frequency are within the configured setting range
Battery reversed	The battery positive and negative are reversed. Please reconnect the battery and check the battery cables connection
Battery low pre-warning	This alarm occurs when the battery reaches the EOD. After the pre-warning, the battery capacity allows two minutes of discharge at full load. The user can set the time ranging from 2 min to 30 min, (2 min by default). Please shut down the load timely
Battery voltage abnormal	When the battery is connected, the system checks that the battery voltage exceeds the normal setting range. Check that the battery terminal voltage exceeds the normal range.
No battery	Check the battery and battery cable connection
Battery test fail	The battery low voltage is detected when the battery has manual or peroidal self-test. Battery replacement is recommended
Battery overtemp	Battery ambient temperature too high. Check that the battery ambient temperature is higher than setting value 40 °C to 60 °C (default: 50 °C)
Battery mode	The UPS is on battery, and the inverter starts
REPO	Shutdown caused by the REPO terminal Normally Closed contact open
Output off, voltage is not zero	When there is no output, the system detects that the output has a voltage
Output short	Check that the output cables are not shorted
System fault	The alarm occurs when model identification is incorrect. Solution: Contact the service manager
Operating on inverter	The UPS output state is on inverter
Bypass mode	The UPS is on bypass
No output	The UPS has no output
Internal communication fails	Check the communication cables are normal

NOTE: If the alarm is caused by the setting value through the software by the Vertiv authorized engineer, and if there is any requirement to change the setting values, please contact the Vertiv representative.

This page intentionally left blank

7 Communication

This chapter mainly describes the Vertiv™ Liebert® ITA2 1-3 kVA UPS communication.

The communication ports include intelligent card port, dry contact port, built-in port, DB9 port, and USB port.

NOTE: It is recommended to use a signal cable length of less than 3 m and maintain distance from the power cable.

7.1 Connecting Built-in Ethernet Port

The built-in Ethernet port supports the HTTP and SNMP protocol. The user can remotely access the UPS via the browser (Google browser recommended) to monitor the UPS in real time. The user can connect one end of the network cable to the Ethernet port of the UPS, and connect the other end to the built-in Ethernet port of the computer.

NOTE: The IPV4 address needs to be in a network segment. For example, if the UPS IPV4 address is 10.168.1.10, the IPV4 address needs to be set to 10.168.1.xxx (XXX is between 0 and 255, but not 10).

NOTE: The subnet mask needs to be consistent and is 255.255.255.0.

NOTE: The gateway address needs to be consistent and 192.168.1.1

There are two ways to set network parameters: static specification and dynamic acquisition.

The static specification indicates that the user can manually change the network parameters of the computer or UPS (including IP address, subnet mask, and gateway address) so that the computer and UPS can communicate normally. The UPS network parameters can be changed in the 'Monitor' page of the LCD 'Settings'.

The dynamic acquisition indicates that the UPS network parameters can be changed in the 'Monitor' page of the LCD 'Settings'. The UPS and computer network cable are connected to a LAN environment. The obtained IP address can be viewed in the 'About' -> 'Network' page of the LCD monitoring panel, as shown in **Figure 7.1** on the next page.

Webpage monitoring function

Open the browser (such as Microsoft Edge), and input the IPv4 address at the address bar to the login interface. After inputting the correct username and password (default name: user, password: 111111), you can monitor the UPS working status.

Figure 7.1 Changing UPS network parameters

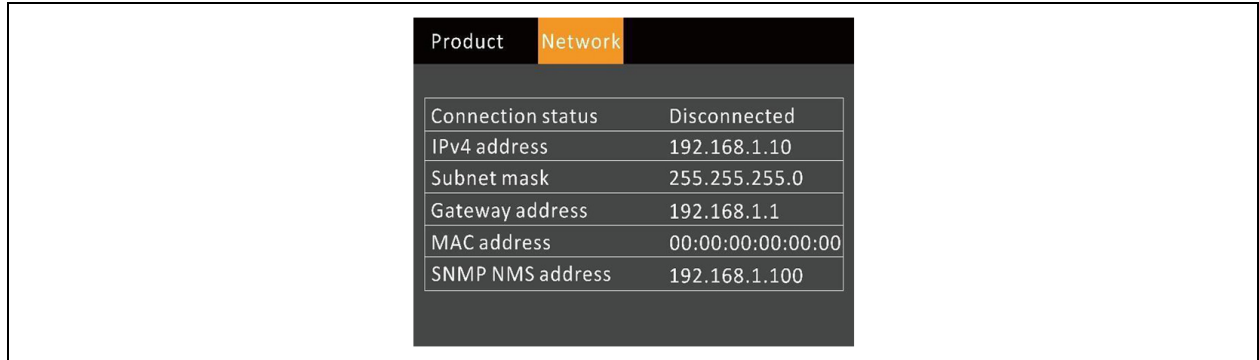

The screenshot shows a web interface with a dark theme. At the top, there are two tabs: 'Product' and 'Network', with 'Network' selected and highlighted in orange. Below the tabs is a table with the following data:

Parameter	Value
Connection status	Disconnected
IPv4 address	192.168.1.10
Subnet mask	255.255.255.0
Gateway address	192.168.1.1
MAC address	00:00:00:00:00:00
SNMP NMS address	192.168.1.100

Browser support

To obtain the best user experience, it is recommended to use the Microsoft Edge, Chrome, or Firefox (latest version required).

Screen resolution

It is recommended to select a display with a resolution of at least 1024×768.

7.2 Connecting Serial Port Communication Cables

The methods to connect the serial port communication cable are as follows:

Connect one end of the DB9 serial port communication cable into the DB9 serial port on the rear panel of the UPS and then connect the other end to the DB9 port of the computer.

The pin functions of DB9 are listed below:

Pin No.	Function
2	Send data
3	Receive data
5	Common terminal

7.3 Installing Intelligent Card

7.3.1 Intelligent Card Port

The card box is connected to UPS through the DB9 serial port communication cable. One end is connected to the DB9 serial port on the rear panel of UPS, and the other end is connected to the serial port of the external card box. The smart card is installed directly in the card box to enable communication between the Intellislot card and UPS. There are two types of Intellislot cards: SIC cards and RDU-SIC cards.

SIC card

SIC card is a network management card, which makes the intelligent devices (such as UPS, air conditioner, static transfer system (STS), sever power management system (SPM), and so on) produced by Vertiv have network communication capability. The SIC card can also be used with the Network Shutdown designed by Vertiv to provide safe automatic shutdown function for the computer, in which the Network Shutdown has been installed, to protect data and reduce loss. The version of SIC card should be V260B003D00 or above.

Refer to the corresponding user manual for the installation and operation guide.

RDU-SIC card

The RDU-SIC card is a network management card. It can build intelligent equipment (such as UPS and PDU) developed by Vertiv to have the capacity for network communication. The SIC card can also connect to the environmental monitoring equipment, including IRM series or 1-Wire series temperature sensor, temperature, and humidity sensor or dry contact signal input and detecting sensors. In the case of an intelligent equipment alarm, it can notify the user in multiple ways: recording, sending a Trap message, sending an E-Mail or sending an SMS. The version of the RDU-SIC card should be V5.21 or above.

The RDU-SIC card provides four approaches to monitor the intelligent equipment and equipment room environment:

Web browser: Monitor the intelligent equipment and equipment room environment through the Web server function provided by the SIC card

Network management system (NMS): Monitor the intelligent equipment and equipment room environment through the SNMP agent function provided by the SIC card

RDU-Manager: RDU-Manager is a part of management software for equipment room. RDU-Manager can be used to monitor the intelligent equipment and equipment room environment through the TCP/IP interface provided by the SIC card.

Centralized management software (Norm): Monitor the intelligent equipment through the Velocity Server service function provided by the SIC card.

The SIC card can also work with the Network Shutdown computer safe shutdown program developed by Vertiv to provide an automatic safe shutdown function for the computer installed with Network Shutdown, in order to prevent data loss.

8 Maintenance



WARNING! Risk of electric shock. Can cause injury or death. Hazardous mains and/or battery voltage exist behind the protective cover. No user-accessible parts are located behind the protective covers. These covers require a tool for removal. Only qualified service personnel are authorized to remove such covers. If maintenance for a rack is needed, notice that the neutral line is live.

Observe the following precautions when working on batteries:

- Remove watches, rings, and other metal objects.
- Use tools with insulated handles.
- Wear rubber gloves and boots.
- Do not lay tools or metal parts on top of batteries.
- Disconnect input power prior to connecting or disconnecting battery terminals.
- If the battery kit is damaged in any way or shows signs of leakage, contact your Vertiv representative immediately.
- Handle, transport, and recycle batteries in accordance with local regulations.
- Check if the battery is accidentally grounded. If it is, remove the source of the ground. Contact with any part of a grounded battery can result in electrical shock. If grounds are removed during installation and maintenance, the possibility of such shock will be minimized..

8.1 Replacing Batteries



WARNING! Risk of electric shock. Can cause injury or death. Disconnect all local and remote electric power supplies before working with the UPS. Ensure that the unit is shut down and power has been disconnected before performing any maintenance.



WARNING! Risk of electric shock and explosion. Can cause equipment damage, personnel injury, and death. Do not dispose of the battery in a fire. The battery may explode. Do not open or damage the battery. Released electrolytes are toxic and harmful to the skin and eyes. If electrolytes come into contact with the skin, wash the affected area immediately with plenty of clean water and seek medical assistance immediately.



WARNING! Risk of electric shock. Can cause equipment damage, personnel injury, and death. A battery can present a risk of electrical shock and high short circuit current.

This chapter describes UPS maintenance, including fan maintenance, battery maintenance, UPS cleaning, UPS state check, and UPS function check.

NOTE: Never attempt to carry out maintenance on the UPS while it is online. Ensure that the UPS has been switched off completely when performing any internal maintenance operations.

8.2 Fan Maintenance

NOTE: In order to avoid personnel injury or damage to the unit, it is recommended to wait until the fan is completely stationary before in-setting fingers or any tools into it.

The UPS fans are expected to run for 20000 hours to 40000 hours continuously. The higher the ambient temperature, the shorter the fan life.

During the UPS operation, please verify the fan status once every half year by confirming that air blows out from the ventilation holes on the rear panel.

8.3 Battery Maintenance

NOTE: Never reverse-connect the battery connections, otherwise, the fire will occur.

NOTE: Never attempt to open batteries since the batteries contain an electrolyte that is potentially harmful to personnel. In the event of an accident with electrolyte, wash the affected area with abundant, clean water, and seek medical assistance immediately.

The internal battery of the UPS is sealed, lead-acid, and maintenance-free battery. The battery life depends on the ambient temperature, charge, and discharge times. High ambient temperature and deep discharge shortens the battery life.

To ensure the battery life, it is required to:

- Keep the ambient temperature ranging from 15 °C to 25 °C.
- Prevent small current discharge. Continuous battery operation time exceeding 24 hours is strictly prohibited.
- Charge the battery for at least 12 hours, if the battery has not been charged for three months at specified ambient temperature, or two months at high ambient temperature.

NOTE: It is recommended to regularly check the screws at the battery connection parts, and fasten them immediately if the connection is not properly tightened.

NOTE: Never attempt to open batteries since they contain electrolyte which is potentially harmful to personnel. In the event of accidental with electrolyte, wash the affected area with abundant, clean water, and seek medical assistance immediately.

NOTE: Measure and record the internal temperature of the battery room.

NOTE: Check whether the battery ports are damaged or hot and whether the chassis and the covers are damaged.

If liquid leakage and damage to the battery are found, place the battery in the anti-vitriol tank, and deal with it according to the local regulations.

The waste lead-acid battery is dangerous waste material. It is one of the environmental emphases to control waste battery pollution. Its storage, transportation, usage, and disposal must follow local law and other criteria regarding dangerous waste material and waste battery pollution prevention.

According to the related regulations, recycling the waste lead-acid battery, and other disposal methods are prohibited. Throwing away randomly the waste lead-acid battery and other improper disposal methods can result in serious environmental pollution, which will be investigated as the legal responsibility.

As the provider of the lead-acid battery, Vertiv has built a perfect service network and recycling system for the waste battery to assist users to deal with the waste battery by law. Contact the Vertiv representative for detailed information about the recycling system for the waste battery.

Vertiv is not liable for the environmental results caused by failure to comply with the notices in this section or to use the waste battery recycling system provided by Vertiv.

8.4 Cleaning UPS

It is recommended to follow the below steps in order to ensure free airflow inside the UPS:

- Clean the UPS periodically, especially the ventilation holes.
- If necessary, clean the UPS with a vacuum cleaner.
- Confirm that the ventilation holes are unobstructed.

8.5 Checking UPS State

It is recommended to check the UPS operation status once every half year. Check the following items:

1. Check if the UPS is faulty: Check if the alarm indicator is on and if any UPS alarms are currently active.
2. Check if the UPS is operating in Bypass mode: Under normal conditions, the UPS operates in Normal mode. If it is observed that it is operating in Bypass mode, determine the reason (operator intervention, overload, internal fault)
3. Check if the battery is discharging: If the AC mains supply is within normal limits, the battery should not be discharged; if found operating in Battery mode, determine the reason (mains failure, battery test, operator intervention).

8.6 Checking UPS Functions

NOTE: UPS functions check procedures may cause power interruption to load!

It is recommended to check the UPS functions once every half year.

Backup the load data before conducting the UPS functions check. The procedures are as follows:

1. Press the power button to check if the buzzer beeps, indicators are ON, and the LCD display is normal.
2. Press the ESC key to check again if the indicators are ON, the LCD display is normal, and the UPS has been transferred to the inverter mode.

9 Options

This chapter introduces the options of the Vertiv™ Liebert® ITA2 1-3 kVA UPS.

9.1 Option List

Refer to **Table 9.1** below for option List.

Table 9.1 Option list

Option name	Model or description Remark	Remark
Battery associated	Battery module	It can increase the backup time of the Vertiv™ ITA2 1-3 kVA UPS, one for each model, 3 in total
	Connection cables of battery module	Used for connection between battery module and UPS or both battery modules. The cable is attached to the battery module. Different cables for different models
	RMKIT1832	For rack installation between the battery module and UPS. Left and right two guide rails for a set, bearing 50 kg, for rack installation use
Communication options	US-SNMPSLOT	Card box for installing smart cards to facilitate UPS connection communication
	SIC	SIC card is used for Intellislot series UPS Remote monitoring of UPS through TCP/IP protocol and Internet; Support remote security shutdown function
	RDU-SIC	RDU-SIC card is used for Intellislot series UPS used for UPS access to RDU-SIC monitoring unit or cascade communication of parallel systems

This page intentionally left blank

10 Technical Specifications

The technical specifications are listed in **Table 10.1** below.

Table 10.1 Technical specifications

Item		Specifications (both standard and long backup model)		
		1 kVA	2 kVA	3 kVA
Input	Rated voltage	220 Vac		
	Voltage range	176 Vac to 288 Vac, at full load		
		100 Vac to 176 Vac, linear increasing 100 Vac, at half load		
	Rated frequency	50 Hz		
	Frequency range	40 Hz to 70 Hz		
	Power factor	≥ 0.99, at full load; ≥ 0.97, at half load; ≥ 0.94, at 30% load		
Output	Rated power	1000 VA/1000 W	2000 VA/2000 W	3000 VA/3000 W
	Voltage	220 Vac/230 Vac/240 Vac; 220 Vac by default		
	Frequency synchronization range	Rated frequency±3 Hz. Configurable range: ±0.5 Hz to ±5 Hz		
	Frequency trackrate	Default: 0.5 Hz/s. Configurable range: 0.2 Hz/s ;0.5 Hz/s, 1 Hz/s (Single UPS)		
	Rated powerfactor	1		
	Crest factor	3:1		
	Voltage harmonic distortion	< 1% (linear load); < 3% (non-linear load)		
	Dynamic response recovery time	Less than 20 ms		
	Overload capacity	Normal mode: 105% to 125%, 10 min; 125% to 150%, 1 min; 150% above, 200 ms; Battery mode: 105% to 125%, 1 min; 125% above, 200 ms		
	Bypass voltage	Default: +20%. Configurable range: +10%, +15% or +20%; Default: -40%. Configurable range: -10%, -20% -30% or -40%		
		Mains efficiency	92%	93%
Battery	Type	Sealed, lead-acid, maintenance-free battery		
	Cell No.	3	4	6
	Rated voltage	36 Vdc	48 Vdc	72 Vdc
	Charge current	8 A (Long back-up)	8 A (Long back-up)	8 A (Long back-up)
2 A (Standard back-up)		2 A (Standard back-up)	2 A (Standard back-up)	
Transfer time	Mains - Battery	0 ms		
	Inverter - Bypass	Synchronous transfer: less than 1 ms		

Table 10.1 Technical specifications (continued)

Item		Specifications (both standard and long backup model)		
		1 kVA	2 kVA	3 kVA
Noise		Front panel less than 50 dB, the rear panel and side panel less than 48 dB		
Panel display mode		Colorful LCD		
Safety		IEC/EN 62040-1:2008+A1:2013		
EMC	Conduction emission	IEC/EN 62040-2 C2		
	Harmonic current	IEC/EN 61000-3-2		
Surge protection		IEC/EN 61000-4-5		
Protection level		IP20		
Ambient condition	Operating temperature	0 to 50 °C		
	Storage temperature	-20 °C to +60 °C (battery excluded); -15 °C to +40 °C (battery included)		
	Relative humidity	5% RH to 95% RH, non-condensing		
	Altitude	≤3000 m; derating when higher than 3000 m		
W×D×H (mm)	Without package	430×400×85	430×470×85	430×540×85
	Net weight (kg)	15.6 (Standard) 7.1 (Long back-up)	19.9 (Standard) 8.6 (Long back-up)	26.7 (Standard) 10 (Long back-up)

11 Appendices

Appendix A: LCD Parameters Setting

Table i.1 LCD Parameters Setting

Menu	Item	Setting range	Default setting
System	Auto restart	Disable, Enable	Enable
	Auto restart delay	0 to 999 seconds	0
	Guaranteed shutdown	Disable, Enable	Disable
	Remote control	Disable, Enable	Enable
	Remote power on delay	0 to 999 seconds	0
	Remote shutdown delay	0 to 999 seconds	0
	IT system compatibility	Disable, Enable	Disable
	Dry contact 1 (Output)	Low battery, On bypass, On battery, UPS fault	Low battery
	Dry contact 2 (Output)	Low battery, On bypass, On battery, UPS fault	UPS fault
	Dry contact 3 (Input)	Battery mode shutdown, Any mode shutdown, Maintain mode	Maintain mode
	Dry contact 4 (Input)	Battery mode shutdown, Any mode shutdown, Maintain mode	Maintain mode

Table i.1 LCD Parameters Setting (continued)

Menu	Item	Setting range	Default setting	
Output	Voltage selection	220 V, 230 V, 240 V	220 V	
	Startup on bypass	Disable, Enable	Disable	
	Frequency selection	Auto, By Pena; Auto, BypDisa; 50 Hz, BypDisa; 60 Hz, BypDisa	Auto, BypEna	
	Inverter sync range	±0.5 Hz, ±1.0 Hz, ±2.0 Hz, ±3.0 Hz, ±4.0 Hz, ±5.0 Hz	±3.0 Hz	
	Bypass voltage upper limit	+10%, +15%, +20%	+20%	
	Bypass voltage lower limit	-10%, -20%, -30%, -40	-40%	
	Bypass frequency range	±5 Hz, ±10 Hz	±10 Hz	
	Run mode	Normal, ECO mode	Normal	
	ECO voltage range	±5%, ±10%, ±15%	±5%	
	ECO frequency range	±1 Hz, ±2 Hz, ±3 Hz	±3 Hz	Aphen the 'Run mode' is set to 'ECO mode'pear only w
	ECO re-qualification time	5, 15, 30 (min)	5	
Battery	Local/Parallel battery total Ah	7 Ah to 3000 Ah	7 Ah for 1 kVA standard, while 14 Ah for 1 kVA long backup; 8 Ah for 2 kVA and 3 kVA standard, while 16 Ah for 2 kVA and 3 kVA long backup	
	EBC number	Automatic, 0 to 10	Automatic	
	Low battery time	2 to 30 (min)	2	
	Battery start time	YYYY-MM-DD HH:MM:SS	2010-01-01 0:00:00	
	Battery test interval	Disable, 8 weeks, 12 weeks, 16 weeks, 20 weeks, 26 weeks	Disable	
	Battery test weekday	Sunday, Monday, Tuesday, Wednesday, Thursday, Friday, Saturday	Wednesday	
	Battery test time	HH:MM:SS	00:00:00	
	Discharge protect time	1 to 4320 (min)	4320	
	Equal charge enable	NO, YES	NO	
	Temperature compensation	Disable, Enable	Disable	
	Replace battery	Button	Button	

Table i.1 LCD Parameters Setting (continued)

Menu	Item	Setting range	Default setting
Monitor	Language	English, Chinese	English
	Date	YYYY-MM-DD	2000-01-01
	Time	HH:MM:SS	00:00:00
	Display orientation	Auto-rotate, Horizontal, Vertical	Auto-rotate
	Audible alarm	Enable, Disable	Enable
	Intellislot	Velocity, YDN23	Velocity
	UPS comm address	1 to 255	1
	IP receive method	Static specification, dynamic acquisition	Dynamic acquisition
	IPv4 address	(‘d’ is a decimal number)	192.168.1.10
	Subnet mask		255.255.255.0
	Gateway address		192.168.1.1
	SNMP NMS address		192.168.1.100
	Change settings password		The password is numeric only and can be set from 0 to 9. The password length is 6

This page intentionally left blank

Appendix B: Glossary

AC	Alternating Current
CB	Circuit Breaker
CSA	Cross Sectional Area
DC	Direct Current
DIP	Dual In-line Package
DSP	Digital Signal Processor
EBC	Battery Module
EMC	Electromagnetic Compatibility
EMI	Electromagnetic /interference
EOD	End-Of-Discharge
EPO	Emergency Power Off
I/O	Input/Output
LBS	Load Bus Synchronization
LCD	Liquid Crystal Display
LED	Light-Emitting Diode
MCB	Miniature Circuit Breaker
NMS	Network Management System
PE	Protective Earth
PFC	Power Factor Correction
RCCB	Residual Current Circuit Breaker
RCD	Residual Current Detector
REPO	Remote Emergency Power Off
RFI	Radio Frequency Interference
SCR	Silicon-Controlled Rectifier
SNMP	Simple Network Monitoring Protocol
STS	Static Transfer Switch
UPS	Uninterruptible Power System

This page intentionally left blank



[Vertiv.com](https://www.vertiv.com)

© 2023 Vertiv Group Corp. All rights reserved. Vertiv™ and the Vertiv logo are trademarks or registered trademarks of Vertiv Group Corp. All other names and logos referred to are trade names, trademarks or registered trademarks of their respective owners. While every precaution has been taken to ensure accuracy and completeness here, Vertiv Group Corp. assumes no responsibility, and disclaims all liability, for damages resulting from use of this information or for any errors or omissions.

UM-IN(EX)-EN-ITA21to3-V1-23-06