



Liebert® EXS™

60kVA UPS User Manual

Copyright by Vertiv Co. Ltd.

The content in this document is subject to change without notice. All rights, including rights of translation, reproduced by printing, copying or similar methods, and even of parts, are reserved. Violators will be liable for damages. All rights, including rights deriving from patent license or registration of utility model or design, are reserved. No part of this document may be reproduced or transmitted in any form or by any means without the prior written consent of Vertiv.

Notice

The purchased products, services, and features are stipulated by the contract made between Vertiv Co., and the customer. All or part of the products, services, and features described in this document may not be within the purchasing scope or the usage scope. Unless otherwise specified in the contract, all statements, information, and recommendations in this document are provided "AS IS" without warranties, guarantees or representations of any kind, either express or implied. The information in this document is subject to change without notice. Every effort has been made in the preparation of this document to ensure the accuracy of the contents, but all statements, information, and recommendations in this document do not constitute a warranty of any kind, express or implied.

Purpose of the Document



This document applies to the Liebert® EXS™ UPS which is the next generation series of UPS that provides continuous, high quality AC Power to business-critical equipment.

This document explains the product description, installation measures, operational workflow, maintenance, and detailed aspects from the user perspective. The figures used in this document are for reference only.

[Please read this manual carefully before installing, maintaining, and troubleshooting, especially the warning information in the manual](#)

Styling used in this Guide

The styles used in the manual will be defined as mentioned in the following table:

Situation	Description
<p data-bbox="248 943 576 976"><u>Warning/Danger/Caution</u></p> 	<p data-bbox="647 871 1378 1368"><i>The Warning/Danger/Caution note indicates a hazardous or potentially harmful situation that can result in death or injury. It also indicates instructions that need to be adhered to, failing which may result in danger and safety issues thereby having an adverse effect on the reliability of the device and security. Even for practices not related to physical injury, the content under the Warning heading is used for precautions which need to be taken which, otherwise, could result in equipment damage, performance degradation, or interruption in service.</i></p>
<p data-bbox="379 1464 448 1498"><u>Note</u></p> 	<p data-bbox="647 1440 1385 1798"><i>The Note section indicates additional and useful information including tips and tweaks. It also calls attention to best practices and industry-best protocols that are standardized and help make maximum utilization of the resources at hand. Helpful information related to the mainstream stuff also comes under the Note heading helping the users get to grips with the definitions, concepts, and terminologies used in the manual.</i></p>

Version History

Date	Revision	Change
11.06.18	V1.0	Initial release.
24.01.19	V1.1	Update Table 3-1.

Special Declaration

Personnel Safety

1. This product must be installed and commissioned by professional engineers of the manufacturer or its authorized agent. Failure to observe this could result in product malfunction or personnel safety risk.
2. Take the time to read this product manual and the safety precaution thoroughly before installing and commissioning this product. Failure to observe this could result in product malfunction or personnel safety risk.
3. This product is not intended for life support equipment application.
4. Never dispose of the internal or external battery of this product in a fire, as it may explode and jeopardize personnel safety when exposed to flame.

Product Safety

1. If this product will be stored or remain de-energized for a long period, it must be placed in a dry and clean environment within specified temperature range.
2. This product should be used in an appropriate operating environment. For details, refer to the section on the environmental requirement in this manual.
3. This product is not designed for application in an environment:
 - Where the temperature and relative humidity are outside the specifications
 - Subject to vibrations or shocks
 - Where conductive dusts, corrosive gases, salts, or flammable gases are present
 - Near heat sources or strong electromagnetic interferences

Disclaimer

Vertiv disclaims any and all responsibility or liability for the defects or malfunction caused by:

- Application range or operating environment outside the specifications
- Unauthorized modification, improper installation or operation
- Force majeure
- Other actions not in compliance with the instructions in this manual

Safety Precaution

This manual contains information concerning the installation and operation of the Liebert EXS 60kVA UPS.

Read this manual thoroughly before installing, using and servicing the UPS.

To reduce the chance of accident, please read the safety precautions very carefully before operation. The 'Caution, Note, Warning' in this user manual and on the product do not represent all the safety points to be observed, and are only supplement to various safety points. Therefore, the installation and operation personnel must receive strict training and master the correct operations and all the safety points before operation.

When operating Vertiv products, the operation personnel must observe the safety rules in the industry, the general safety points and special safety instructions provided by Vertiv.



- 1. The UPS must be installed, commissioned and serviced by engineers designated by the manufacturer or its agent. Failure to observe this could result in personnel safety risk, UPS malfunction and invalidation of warranty.*
- 2. The UPS has been designed for commercial and industrial use only, and is not recommended for use in life support applications.*



This is a product for commercial and industrial application in the second environment installation restrictions or additional measures may be needed to prevent disturbances.

The UPS with standard configuration is a category C3 product. Installation restrictions or additional measures may be needed to prevent disturbances. The UPS adding C2 EMC option based on the standard configuration is a category C2 product for a residential environment or commercial and industrial application in the second environment.



1. The UPS complies with 2014/35/EU (LVD), 2014/30/EU (EMC), 2011/65/EU (Rohs) and the following product standards for UPS:

- IEC/EN 62040-1, General and safety requirements for UPS*
- IEC/EN 62040-2: Class C2 compliant*
- IEC/EN 62040-3: Performance requirements and test methods*

2. Continued compliance requires installation in accordance with these instructions and the use of manufacturer approved accessories only.



1. Before moving or rewiring the UPS, disconnect mains input power and the battery and make sure that the UPS is completely shut down. Otherwise, the output terminal may carry live voltage, presenting an electric shock hazard.
2. Liquid or other irrelevant external objects are prohibited inside the UPS.
3. In case of a fire, a dry chemical fire extinguisher is essential. Using a foam fire extinguisher will cause electric shock.
4. To prevent the radio frequency of output cables from disturbing other electric equipment, it is recommended to use the UPS output cable with the length less than 10m.



High earth leakage current

1. Earth connection is critical before connecting the input supply (including both mains supply and battery).
2. Earth leakage current is less than 2500mA.
3. Transient and steady state earth leakage currents, which may occur when the equipment is started, should be taken into account in the selection of instantaneous RCCBs or RCD devices. RCCB which is sensitive to unidirectional DC pulse (class A) and insensitive to transient state current pulse must be selected.
4. Note also that the earth leakage currents of the load will be carried by the RCCBs or RCDs.
5. The equipment must be earthed in accordance with the local electrical code of practice.



Backfeeding protection

This UPS is fitted with a dry contact closure signal for use with an external automatic disconnect device (supplied independently) to protect against backfeeding voltage into the incoming terminal through the rectifier or bypass switch circuit. A label must be added at all external incoming primary supply disconnect device to warn service personnel that the circuit is connected to a UPS. The text of the label has the following meaning: Risk of voltage backfeed! Isolate the UPS, then check for hazardous voltage between all terminals including the protective earth before working on this circuit.



User serviceable components (For service personnel)

- 1. All equipment maintenance and servicing procedures involving internal access requires the use of a tool and should be carried out only by trained personnel. There are no user-serviceable parts behind covers requiring a tool/key for removal.*
- 2. The UPS meets the safety requirements completely in operator access area. Only service personnel can contact the hazardous voltage inside the UPS. However, the risk of contacting these voltages is minimized because the components with hazardous voltage may be contacted only by using a tool to remove the protective cover. No risk will exist if you follow the general norms and in accordance with the procedures recommended in this manual on equipment operation.*



Battery voltage exceeds 400Vdc (For service personnel)

- 1. All physical battery maintenance and servicing procedures requires the use of a tool and should be carried out only by trained personnel.*
- 2. Operation on the battery will result in electric shock and high short-circuit current, therefore, before operating the battery, the following should be observed:*
 - Remove the watches, rings and other metal objects.*
 - Use the tools with insulation handle.*
 - Wear rubber glove and shoes.*
 - Avoid to place the tools and metal objects on the battery surface.*
 - Cut off the charge power supply before connecting or disconnecting the battery terminals.*
 - Check whether the battery is earthed accidentally, if yes, please disconnect the earthing. Contacting any earth battery parts will result in electric shock. Therefore, make sure that the battery is not earthed during installation and maintenance.*
- 3. Battery manufacturers provide the details of the precautions to be observed when working on, or in the vicinity of the batteries. These precautions should be followed implicitly at all times. Attention should be paid to the recommendations concerning local environmental conditions and the provision of protective clothing, first aid and fire-fighting facilities.*



- 1. When selecting the UPS system upstream distribution protection equipment, ensure that it complies with the local electric regulations.*
- 2. The KAIC (optional) are required to obtain the conditional short circuit current rating, I_{cc} at 30kA symmetrical rms. The specified upstream breakers should comply with an IEC 60269 series standard.*
- 3. When the internal fuse of the UPS is damaged, it must be replaced with fuse of the same electric parameters from the designated manufacturer, and operated by qualified personnel.*

TABLE OF CONTENTS

1 Product Introduction.....	1
1.1 Features.....	1
1.2 Design Concept.....	2
1.2.1 System Design.....	2
1.2.2 Working Principle of Single Module UPS.....	2
1.2.3 Bypass.....	3
1.2.4 System Control Principle.....	3
1.2.5 UPS Power Supply Switch Configuration.....	5
1.3 Parallel System.....	6
1.3.1 Parallel System Features.....	7
1.3.2 Parallel System Requirements	7
1.4 UPS States and Operating Modes.....	7
1.5 Battery Management.....	11
1.5.1 Normal Function.....	11
1.5.2 Advanced Function	12
1.5.3 Battery Temperature Compensation.....	13
1.6 Battery Protection.....	14
2 Mechanical Installation	15
2.1 Precautions.....	15
2.2 Transportation.....	16
2.3 Tools	17
2.4 Unpacking.....	18
2.5 Initial Inspection.....	19
2.6 Environmental Requirements.....	20
2.6.1 UPS Room.....	20
2.6.2 Reserved Space.....	20
2.6.3 Battery Room.....	21
2.6.4 Storage Environment.....	21
2.7 Mechanical Requirements.....	22
2.7.1 Moving Cabinet.....	22
2.7.2 Clearance.....	22
2.7.3 Cable Access Mode.....	22
2.8 Installation Drawings.....	23
3 Electrical Installation	24
3.1 Wiring of Power Cable	24
3.1.1 System Configuration.....	24
3.1.2 Maximum Steady State AC and DC Currents.....	24

3.1.3 Recommended CSA Of UPS Cable	25
3.1.4 Selection of UPS I/O Switch.....	25
3.1.5 Power Cable Connecting Terminal.....	26
3.1.6 Protection Ground.....	26
3.1.7 Notes	26
3.1.8 Power Cable Connection Steps.....	26
3.2 Wiring of Signal Cable.....	30

4 Operator Control and Display Panel31

4.1 Introduction.....	31
4.1.2 LED Indicators	31
4.1.3 Audible Alarm (Buzzer).....	32
4.1.4 LCD And Functional Keys.....	32
4.1.5 LCD Menu Structure.....	33
4.2 LCD Screen Types	33
4.2.1 Start-up Screen.....	33
4.2.2 Flow Screen.....	34
4.2.3 Main Menu Screen.....	34
4.2.4 Submenu Screen	35
4.2.5 Default Screen	41
4.3 Prompt Window.....	42
4.4 UPS Alarm Message List.....	44

5 UPS Operating Instructions50

5.1 Brief Introduction.....	50
5.1.1 Precautions	50
5.1.2 Power Switch.....	50
5.1.3 Check Before Start-up.....	51
5.2 UPS Start-up Procedures.....	52
5.2.1 Start-up Procedures in Normal Mode.....	52
5.2.2 Start-up Procedures in Battery Mode (Battery Cold Start).....	54
5.3 Procedures for Transferring Between Operating Modes.....	54
5.3.1 Transfer from Normal Mode to Battery Mode.....	54
5.3.2 Transfer from Normal Mode to Bypass Mode	54
5.3.3 Transfer from Bypass Mode to Normal Mode	56
5.3.4 Transfer from Normal Mode to Maintenance Bypass Mode.....	56
5.3.5 Transfer from Maintenance Bypass Mode to Normal Mode.....	57
5.4 Battery Test Procedures.....	58
5.5 System Test Procedure.....	59
5.6 UPS Shutdown Procedures	60
5.6.1 Procedures for Completely Powering Down UPS.....	60

5.6.2 Procedures for Completely Powering Down UPS While Maintaining Power to Load.....	60
5.7 EPO.....	61
5.8 UPS Reset Procedures After EPO.....	61
5.9 Automatic Restart.....	62
5.10 Selecting Language.....	62
5.11 Changing Current Date and Time.....	64
5.12 Setting Password.....	65
6 Parallel System and LBS System	69
6.1 General.....	69
6.2 Requirements.....	69
6.3 System Installation Procedures.....	69
6.3.1 Preliminary Checks	70
6.3.2 Cabinet Installation	70
6.3.3 Power Cables.....	71
6.3.4 Parallel Cables	71
6.3.5 Remote EPO.....	71
6.4 Operation Procedures for Parallel System	72
6.4.1 Check Before Start-up	72
6.4.2 Parallel System Parameters Setting.....	73
6.4.3 Power-on Procedures for Parallel System.....	73
6.4.4 Maintenance Bypass Procedures.....	74
6.4.5 Procedures for Isolating One UPS Module from Parallel System.....	76
6.4.6 Procedures for Inserting One Isolated UPS Module in Parallel System.....	76
6.4.7 Procedures for Completely Powering Down UPS	77
6.4.8 Procedures for Complete UPS Shutdown While Maintaining Power to Load.....	77
6.5 LBS System.....	78
6.5.1 Overview	78
6.5.2 Cabinet Installation	78
6.5.3 Connecting Power Cables.....	79
6.5.4 Connecting LBS Cables.....	79
6.5.5 LBS Parameters Setting.....	80
6.5.6 LBS System Commissioning.....	80
7 Communication	81
7.1 Installing Intelligent Card.....	81
7.1.1 Intelligent Card Port.....	81
7.1.2 Intelligent Card Option.....	81
7.1.3 Installation Procedures	83
7.2 Connection Cables for Dry Contact Port.....	84
7.3 Connecting Parallel Cables.....	89

7.4 Connecting LBS Cables.....	89
8 Maintenance	90
8.1 Fan Maintenance.....	90
8.2 Battery Maintenance.....	90
8.3 Cleaning UPS.....	91
8.4 Checking UPS State	92
8.5 Checking UPS Functions.....	92
9 Options	93
9.1 List of Options	93
9.2 Parallel Cables	94
9.3 LBS Cables.....	94
9.4 Communication Options and Temperature Sensor.....	95
9.5 BCB Box.....	96
9.5.1 Overview	96
9.5.2 Connection of BCB Box.....	97
10 Specifications	99
10.1 Conformance and Standards.....	99
10.2 Environmental Characteristics.....	99
10.3 Mechanical Characteristics.....	100
10.4 Electrical Characteristics (Input Rectifier).....	100
10.5 Electrical Characteristics (Battery).....	100
10.6 Electrical Characteristics (Inverter Output).....	101
10.7 Electrical Characteristics (Bypass Input).....	101
Appendix 1 LCD Parameters Setting.....	99
Appendix 2 Glossary	99
Appendix 3 Hazardous Substances and Content	99

1 Overview

The Liebert® EXS 60kVA UPS (UPS for short) is a monolithic transformer-free UPS which delivers reliable & high-quality AC power for mission-critical applications such as datacenters, computers, communication systems, healthcare, railway, and process & automation equipment.

This chapter introduces the features, design concept, operating principle, UPS state and operation mode, and specifications of the UPS.

1.1 Features

The features of UPS are as follows:

- Output power factor is up to 1.
- Double conversion efficiency up to 96% and ECO mode efficiency up to 99%.
- Compact footprint with multiple internal runtime configurations.
- Parallel capability for capacity and redundancy.
- Unity input power factor.
- Tolerates wide range of input voltage i.e. 228-475Vac.
- Flexible battery configuration: internal battery (two sets of 32-block, one set of 40-block), external battery (26~40-block).
- Large power charger with maximum charging current of 25A built into the power module can provide customers with fast charging.
- Innovative air channel design improves the reliability of the product.
- Colorful LCD display panel to intuitively inform you about the UPS operating status and operating parameters
- Features ECO and smart sleep mode functions, which helps to save energy to the maximum extent.

1.2 Design Concept

1.2.1 System Design

This section introduces the working principle of the UPS single module. The UPS adopts AC-DC-AC converter (as shown in Figure 1-1).

- The first stage conversion (AC-DC) adopts a three-phase high frequency rectifier to convert the three-phase input voltage into stable DC bus voltage.
- The second stage conversion (DC-AC) adopts a three-phase high frequency inverter to convert the DC power supply into the three-phase AC input voltage.

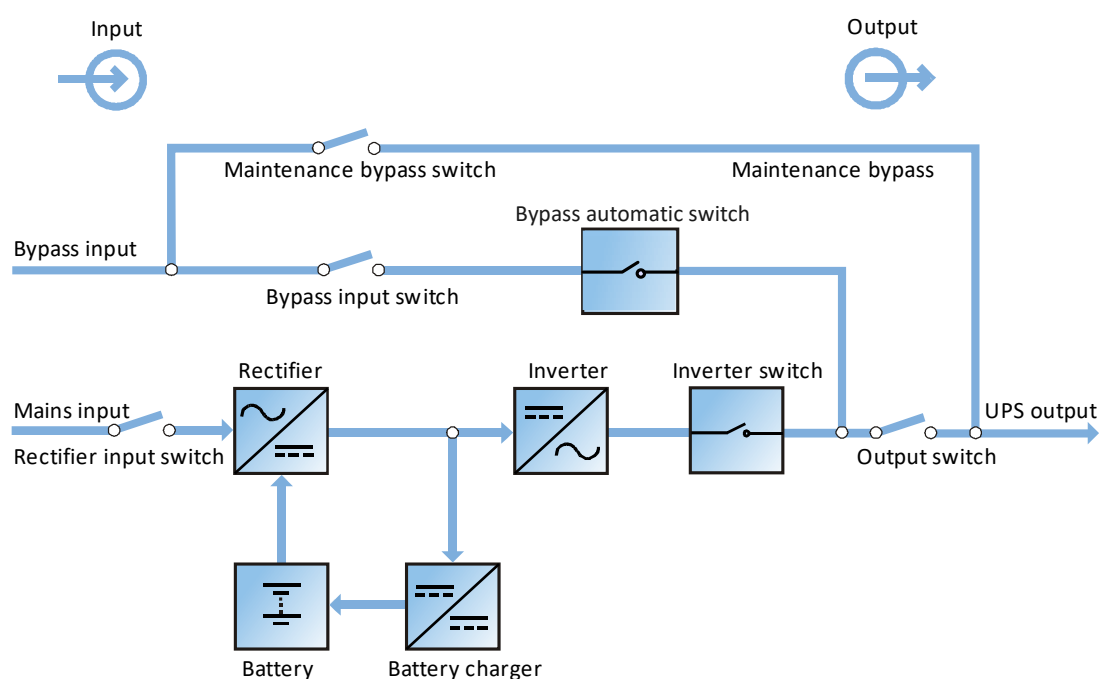

Figure 1-1 Block diagram for working principle of UPS single module

1.2.2 Working Principle of Single Module UPS

The working principle of single module UPS is as follows:

1. The UPS is composed of mains input (main and bypass), rectifier/PFC, charger, inverter, bypass, battery, and output.
2. When the mains is normal, the rectifier and inverter work together to supply the loads and charge the battery.
3. When the mains is outside the UPS input supply tolerance levels,
 - i) The rectifier/PFC circuit boosts the battery voltage and supplies it to the inverter.
 - ii) The inverter then converts it into pure sine wave AC power and supplies the AC power to the load. If the battery voltage drops to End of Discharge (EOD) voltage and the mains is still not recovered, the UPS will shut down (if the system uses split bypass configuration and the bypass is normal, the

system will be transferred to bypass). The battery EOD voltage is preset. The battery maintains the UPS operation until the battery voltage is reduced to EOD voltage and the UPS shuts down, this time is called 'Backup Time'. The length of backup time depends on the battery capacity and the loads.

4. After the input mains returns within tolerance levels, the UPS automatically transfers from Battery mode to Normal mode, and the rectifier and inverter work together to supply the loads and charge the battery.

1.2.3 Bypass

The loads can be supplied by the inverter or the bypass through the intelligent control of the 'Bypass Automatic Switch' (as shown in Figure 1-1). In normal circumstances, the loads are supplied by the inverter, in which case the automatic inverter switch is closed at inverter side. In the event of overload (the overload delay time expires) or inverter failure, the automatic inverter switch is opened, and the ' Bypass Automatic Switch ' module automatically transfers the loads to the bypass.

In normal operating state, the inverter output must be fully synchronized with the bypass to realize the uninterrupted transfer between inverter and bypass.

Therefore, when the bypass frequency is within the synchronization range, the inverter control circuit synchronizes the inverter output frequency with the bypass frequency and phase.

In addition, the UPS has a manual maintenance bypass switch to shutdown the UPS during maintenance. In this situation, the bypass supplies the critical loads directly through the maintenance bypass.



When the load is supplied by the bypass or maintenance bypass, the power supply quality will be uncertain.

1.2.4 System Control Principle

Normal Operation

Normal mode: It means that the UPS has normal input mains, the rectifier and inverter operate normally, the load is supplied by the inverter, the battery circuit breaker is closed, and the battery is in stable floating charge state.

(Parallel System) Note: As the UPS single module outputs are connected in parallel, the system checks that the inverter control circuits are perfectly synchronized with one another and with the bypass in terms of both frequency and phase, and that they have the same output voltages. Current supplied to the load is automatically divided among UPSs. When synchronization is in progress; a warning message is displayed.

Mains Abnormal

When the mains fails or is abnormal, the rectifier will automatically stop working, and the system will transfer to battery output (through inverter). The length of the operation time in battery mode depends on the load and the battery capacity. During this period, if the battery voltage drops to the EOD voltage and the mains is still not recovered, the inverter will automatically stop working, and the UPS operator control and display panel will display corresponding alarm messages. If the system uses split-bypass configuration and the bypass is normal, the system will transfer to bypass.

Mains Recovery

When the mains resumes normal within allowable time, the rectifier automatically starts and supplies the load and charges the battery again. Therefore, the power supply to the load will not be interrupted.

Battery Disconnection

To disconnect the external battery from the UPS system for maintenance, use the external isolating switch. At present, except for the battery backup function upon mains failure, other functions and all the steady state performance of the UPS will not be affected.

UPS Module Failure

In case of inverter failure and output fuse blowout, the load is automatically transferred to the bypass, and the output power supply is not interrupted. In this situation, please contact the local customer service center of Vertiv for technical support.

(Parallel System) In the event of a fault in a UPS module, it will automatically exit from the parallel system. If the system is still capable of providing the required load, the remaining modules will continue to supply the load without interruption. If the remaining modules are no longer capable of fulfilling the power requirements, the load will be transferred automatically to the bypass.

Overload

- If the inverter is overloaded or if the inverter current remains outside the specifications longer than the specified time, the load will automatically be transferred to the bypass without power interruption.
- If both the overload and the current are reduced to a level within the specified range, then the load will be transferred back to the inverter. In case of output short circuit, the load will be transferred to the bypass, and the inverter will shut down. Five minutes later, the inverter will start up automatically. If the short circuit is removed at this point, the load will be transferred back to the inverter. The transfer is determined primarily by the features of the protective device of the system.

In the above two situations, the UPS operator control and display panel will display alarm messages.

(Parallel System) The control logic system constantly monitors load requirements and controls the power supplied by each UPS module. If the overload condition is sustained for more than a preset time or when the number of active modules is unable to satisfy load requirements, the load will be transferred to the bypass. The load returns to the inverter if the power is reduced to a value that can be sustained by the number of active modules in the system.

Maintenance bypass

The UPS has a second bypass circuit, i.e. maintenance bypass, which provides a safe working environment for the engineers to provide regular maintenance or repair to the UPS system and at the same time provide unregulated mains supply to the loads. The maintenance bypass can be selected manually through the maintenance bypass switch, and can be disconnected by turning the switch to OFF.

1.2.5 UPS Power Supply Switch Configuration

The UPS has five switches: rectifier input switch Q1, bypass input switch Q2, maintenance bypass switch Q3, output switch Q5, and N line switch QN.

Figure 1-2 describes the block diagram of the UPS module. The UPS is available in split bypass configuration (i.e., the bypass adopts independent mains input) and common input configuration.

- If the system adopts common input configuration, the UPS has copper shorting bar of common input configuration, and the bypass input switch (Q2) and rectifier input switch (Q1) would be linked together.

- If the system adopts split bypass configuration, just remove the copper shorting bar of common input configuration of the UPS.

During the normal operation of the UPS, except for the maintenance bypass switch Q3, other switches shall be closed.

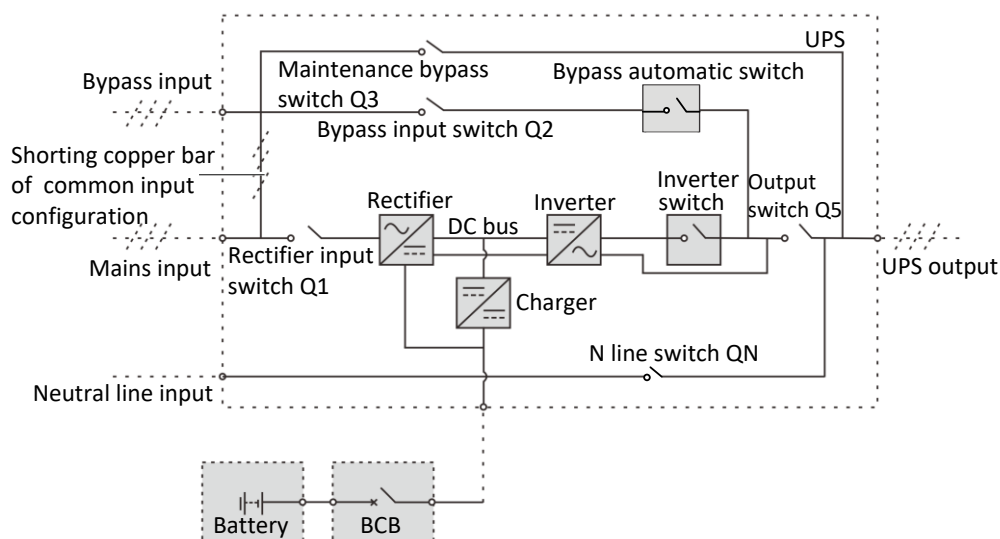

Figure 1-2 UPS Power Supply Switch Configuration



The mains input and bypass input share the same neutral line.

Battery Circuit Breaker (BCB) The external battery is connected to the UPS via the BCB. The BCB box is an option that is installed close to the battery. The BCB is manually closed and has a shunt tripping coil. When the system is faulty and the BCB needs to be disconnected, the UPS control circuit sends a signal to the shunt tripping coil to trip the BCB. It also has a magnetic trip facility for overload and short circuit protection.

1.3 Parallel System

Up to four UPS modules can be parallely connected to form a parallel system to increase the system capacity and reliability. The load is shared equally between the paralleled UPS modules.

In addition, two set of UPS module or parallel system can be configured as a dual bus system. Each parallel system has independent output. Output synchronization is achieved through the LBS cable or LBS device, thus enabling seamless load transfer between the two parallel systems or single module through the STS device.

1.3.1 Parallel System Features

1. The hardware and software of parallel system are completely identical to that of the single module. Parallel system configuration can be achieved through configuration software settings.
2. Parallel cables are connected in a ring, offering system reliability and redundancy.
3. The total load of the parallel system can be seen from the LCD of each UPS.

1.3.2 Parallel System Requirements

A group of paralleled modules act as if they were one large UPS with the benefit of greater reliability. The following requirements apply to ensure that all modules are utilised equally and that they comply with relevant wiring rules:

1. All UPS modules must be of the same series and connect to the same bypass source.
2. The N line of bypass and rectifier input sources must be connected to the same neutral line terminal.
3. Any RCD, if installed, must be of an appropriate setting and located upstream of the common neutral line input terminal. Alternatively, the device must monitor the protective earth current of the system. Refer to *Warning: High earth leakage current before Contents*.
4. Parallel system consists of two or more UPS modules, the bypass load sharing inductors (optional) should be selected.

1.4 UPS States and Operating Modes



For the LED indicators introduced in this section, refer to *4.1.1 LED Indicators*. The operating modes are as follows:

- Normal mode
- Battery mode
- Bypass mode
- Maintenance bypass mode
- ECO mode
- Parallel redundancy mode (system expansion)
- Frequency converter mode
- LBS mode

Normal mode

The UPS inverter continuously supplies the critical AC load. The rectifier draws power from the commercial AC source and converts it into DC power for the inverter and the battery charger. The battery charger maintains the battery in a fully charged and optimum operational condition. The inverter converts the DC power into clean and regulated AC power which is supplied to the critical load (conditioned line). The static switch monitors and ensures that the inverter tracks the bypass supply frequency. In this condition any automatic transfer to the bypass supply (due to an overload etc.) is frequency synchronized and does not cause interruption to the critical load.

In Normal mode, the run indicator (green) is on, the alarm indicator is off, and the buzzer is silenced.

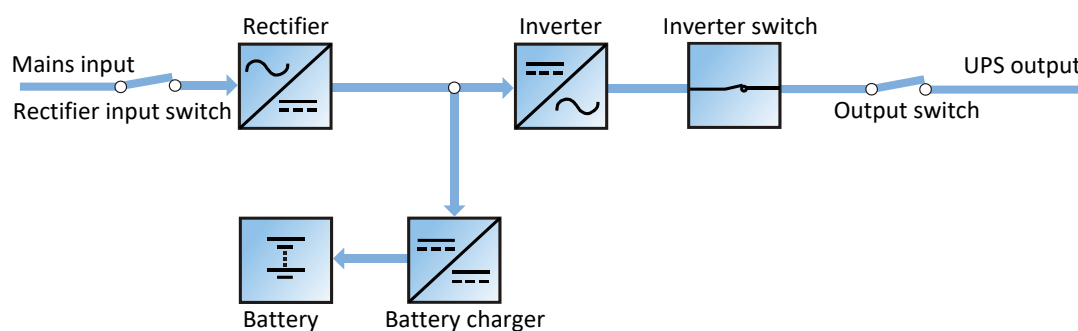

Figure 1-3 Schematic Diagram of Normal Mode

Battery mode

Upon mains failure or voltage is out of range, the rectifier and internal charger will stop running, and the battery will supply power to the load through the inverter. When the mains is recovered, the system returns to the normal mode without any manual intervention, and the power to the load is not interrupted.

In Battery mode, the run indicator (green) is ON, alarm indicator (yellow) is ON, and the buzzer beeps every second. The 'Current' page in LCD will display 'On Battery'.



1. The battery has been fully charged before delivery. However, some loss of capacity is inevitable during transportation and storage. Therefore, it is important to charge the battery for eight hours before connecting the UPS into operation for the first time, to ensure it can provide adequate backup time.
2. The Liebert EXS UPS supports cold start function, while this function is activated, UPS can be powered using battery mode without availability of input power supply. Therefore, the battery power can also be utilized independently for improving the system availability.

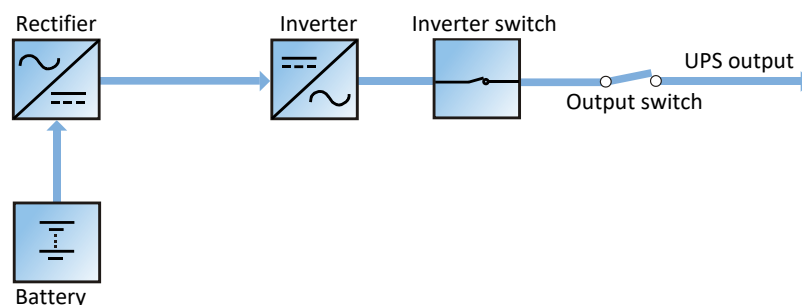

Figure 1-4 Schematic Diagram of Battery Mode

Bypass mode

If the overload overtime, inverter or rectifier failure occurs during the UPS operation in Normal mode, the UPS will be transferred to Bypass mode, i.e., the load is powered by the bypass source, which comes directly from the mains input. If the rectifier is normal, the battery will be charged by internal charger.

In Bypass mode, the run indicator (green) is ON, alarm indicator (yellow) is ON, and the buzzer beeps every second. The 'Current' page in LCD will display 'On Bypass'.

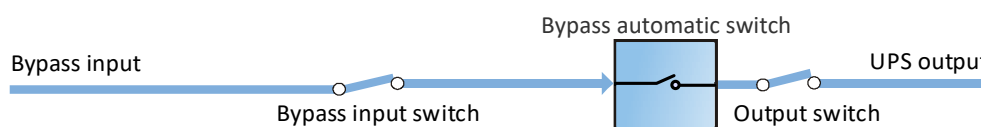

Figure 1-5 Schematic Diagram of Bypass Mode



In the event of a mains failure or if the mains voltage is outside tolerance while the UPS is in Bypass mode, the UPS will shut down and the power supply to the load will be interrupted.

Maintenance Bypass mode

If the UPS maintenance or service is required, you may use the manual maintenance bypass switch to transfer the load to maintenance bypass, without any power interruption to the load. This maintenance bypass switch is fitted in all UPS modules and rated for full load of a single module.

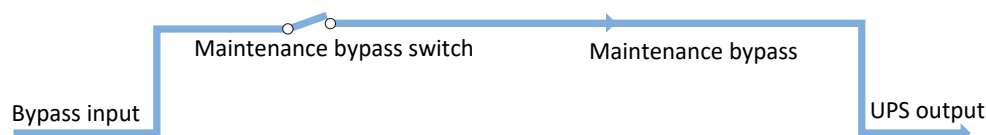

Figure 1-6 Schematic Diagram of Maintenance Mode



In the event of UPS malfunctions or abnormal operation, contact your nearest Vertiv branch office or local service center. NEVER attempt to repair the UPS yourself, as this may result in injury to personnel and/or damage to equipment.

ECO mode

If ECO mode is selected, all power switches and the battery switches are closed except for the maintenance bypass switch, and the system prefers to place the load on the bypass, to save energy. When the bypass supply is within the range of normal frequency and voltage (adjustable), the load is powered by the bypass, with the inverter on stand-by; when the voltage and/or frequency of the bypass supply exceeds the pre-defined and adjustable limits, the system is transferred to the inverter output, and the transfer time for switching from bypass to inverter is less than 5 ms. In this mode, the system can normally charge the battery.

ECO mode is an energy-saving operating mode. Eco mode can be used to reduce power losses by feeding the power through bypass to the load that is not sensitive to mains power quality.

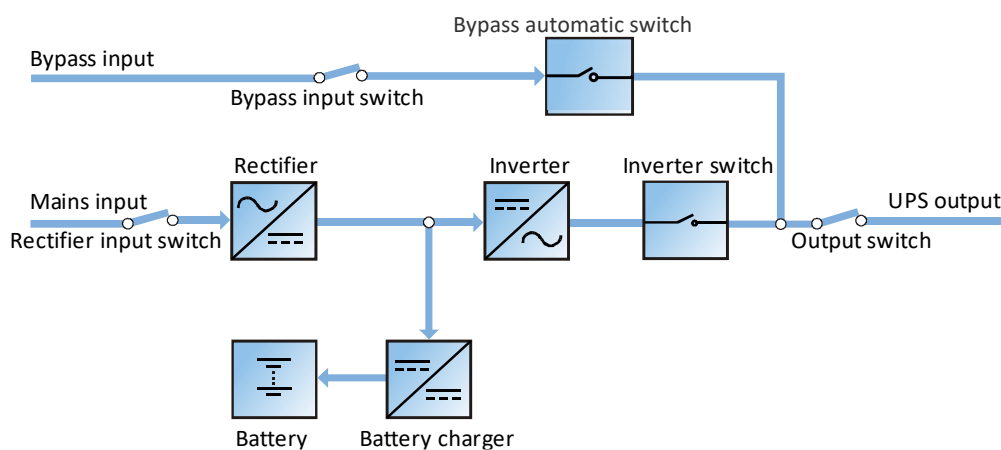

Figure 1-7 Schematic Diagram of ECO Mode



1. In ECO mode, if the bypass fails or the bypass voltage exceeds normal limits, the UPS is transferred to Normal mode (providing the output is not overloaded). However, if the bypass fails or the bypass voltage exceeds normal limits while the output is overloaded, the UPS will not be transferred to Normal mode, but will shut down the Bypass.
2. In ECO mode, the efficiency of the UPS increases to 99%.
3. In ECO mode, the load is not protected against mains distortion.

Parallel redundancy mode (system expansion)

For higher capacity or higher reliability, outputs of multiple UPS modules can be programmed for directly paralleling while a built-in parallel controller in each UPS module ensures automatic load sharing. The parallel system can be composed of up to four UPS modules. For the operation principle diagram of the parallel redundancy mode, see Figure 6-1.

Frequency converter mode

The UPS can be programmed into frequency converter mode for either 50Hz or 60Hz stable output frequency. The input frequency may vary from 40Hz to 70Hz. In this mode, it is required to open the maintenance bypass switch to disable the bypass operation, and the battery becomes optional depending on any requirement to operate in battery mode.

LBS mode

A dual-bus system consists of two independent UPS systems, with one or more parallel UPS modules each. The dual-bus system is highly reliable and is applicable to load with multiple inputs. For single-input load, an STS can be installed to power the load. For the operation principle diagram of the LBS mode, see Figure 6-5 and Figure 6-6.

1.5 Battery Management

The following battery management functions are set by the service engineer through the Vertiv setting software.

1.5.1 Normal Function

1. Constant current boost charge

Adopt the constant current (within battery charging limit) to charge the battery. The function can be used for quick battery capacity recovery. The charge current can be set.

2. Constant voltage boost charge

Adopt the constant voltage to charge battery. The function can be used for quick battery capacity recovery. For VRLA batteries, the maximum boost charge voltage should not exceed 2.4V/cell.

3. Float charge

The charging method is used to hold the full capacity of the battery. The float charge voltage is generally low. The function can balance the capacity loss due to battery self-discharging and can be used for battery capacity recovery.

For VRLA batteries, the float charge voltage should be between 2.2V/cell and 2.3V/cell.

4. Automatic transfer to float charge

When the charge current is less than 'Threshold of Equalize Charge to Float Charge' or 0.5A, the charger automatically transfers from boost charge to float charge.

When boost charge time exceeds the limit of 'Equalize Charge Protect Time Limit', the charger forcibly transfers to float charge for protecting the battery.

5. Float charge temperature compensation (optional)

This function needs to be used in conjunction with the battery temperature detection device. The Vertiv battery temperature sensor is a standard option for your selection.

6. EOD protection

When the battery voltage drops to the EOD voltage, the battery converter automatically shuts down and the battery is inhibited to avoid further battery discharge. The EOD voltage is settable from 1.60V/cell to 1.90V/cell (VRLA).

7. Battery low pre-warning time

The battery low pre-warning time is adjustable between 3min and 60min. The default setting is 5min.

8. Maximum battery discharge time

When the battery has small current discharge for a long time, the battery is over discharged and even has unrecoverable damage, so it is essential to set the battery discharge time to protect the battery. The time limit setting shall be configured by Vertiv engineer through the software settings.

9. Maximum boost charge protection time

To protect against the battery overcharge damage caused by a long-time boost charge, a protect time setting is essential. The time limit setting shall be configured by Vertiv engineer through the software settings.

1.5.2 Advanced Function

The UPS provides battery maintenance test function. At periodic intervals, 20% of the battery's rated capacity is automatically discharged, and the actual three-phase load must exceed 20% of the nominal UPS capacity. If the load is less than 20%, the automatic discharge cannot be executed. The periodic interval can be set from 30 to 360 days. The battery maintenance test function can be disabled through the Vertiv setting software.

Conditions: Battery at float charge for at least 5h, load equal to 20% ~ 100% of rated UPS capacity.

Trigger: Automatically, or manually through the command of battery maintenance test in LCD.

Interval: 30~360 days (default setting: 60 days).

The UPS also provides battery capacity self-test function: Periodically test the battery activity, test the battery residual capacity, evaluate the battery quality, and then provide corresponding measures. The capacity self-test is started by the user through the operator control and display panel. During the capacity self-test, the battery will continuously discharge to the battery undervoltage shutdown threshold. After the self-test is completed, the system updates the battery curve table. The capacity self-test command is valid only one time, without any memory. During the capacity self-test, if the battery maintenance requirement is met, the system generates audible/visual alarm and give corresponding records.

Conditions: System load rate within 20% ~ 100%, battery float charge at least 5h, and generator not connected; the current system is in float charge state.

Trigger: Start up through the LCD.



1. *The battery will continuously discharge to the battery undervoltage shutdown threshold and then the battery transfers to the charging state. When the capacity self-test is completed, the system updates the battery curve table.*
2. *The user can manually stop the capacity self-test operation through the LCD.*
3. *The battery capacity self-test needs to guarantee the discharge time not less than 6min, otherwise the battery self-learning time may be insufficient and the battery curve will not be updated.*

1.5.3 Battery Temperature Compensation

The UPS system has battery charge temperature compensation function. When the ambient temperature is increased, the DC bus voltage (which charges the battery) is reduced correspondingly to provide optimal charging voltage for the battery, thus prolonging the battery service life time.

This function must be used in conjunction with the Vertiv battery temperature detection device (a standard option).

1.6 Battery Protection

The following battery protection functions are set by the Vertiv engineer through the software settings.

Battery low pre-warning

The battery low pre-warning occurs before the EOD. After this pre-warning, the battery should be able to discharge with full load for three remaining minutes. The time can be configured from 3min to 60min.

EOD protection

When the battery voltage drops to the EOD voltage, the battery converter automatically shuts down. For VRLA batteries, the EOD voltage is adjustable from 1.60V/cell to 1.90V/cell (VRLA).

BCB alarm

The BCB alarm occurs when the external BCB opens, if you select the Vertiv BCB (optional).

The external battery connects to the UPS through the BCB. The BCB is manually closed and tripped by the UPS control circuit.

2 Mechanical Installation

This chapter briefly introduces the mechanical installation of the UPS, including the precautions, initial inspection before installation, environmental requirement, mechanical requirement and installation diagram.

2.1 Precautions

No two sites are the same, therefore this section provides general guidelines, procedures, and methods for installation engineers, who shall adapt the installation to meet the actual conditions.



Professional Installation Required

1. The UPS should be installed by a qualified engineer in accordance with the information provided in this section. In the event of any problems, contact your local Vertiv service center immediately.
2. The UPS must NOT be switched ON without the approval of the commissioning engineer.
3. In the case of any equipment or items not covered in this section, refer to the specific mechanical and/or electrical installation instructions provided with such items.



The UPS can be connected to IT, TN and TT AC distribution systems (IEC60364-3) and must be of 3-phase 5-wire (A, B, C, N, PE) system.



Battery Danger

Take special care when installing batteries. When connecting batteries, the battery terminal generates DC high voltage, which is fatal to human being.

1. Please wear safety glasses to protect the eyes from being damaged by arc.
2. Remove all the metal items, including finger rings, watch, etc.
3. Use tools with insulated handle.
4. Wear rubber gloves.
5. If the battery has electrolyte leakage or is damaged, it must be replaced. Place the battery into the container that can withstand sulfuric acid and dispose it according to the local regulations.
6. If the skin contacts the electrolyte, immediately flush it with water.

2.2 Transportation

Railroad transportation and shipping are the recommended means of transportation. If truck transportation is unavoidable, choose roads that are less bumpy to protect the equipment.

The UPS cabinet is heavy (see Table 10-3 for its weight). It is recommended to use mechanical equipment such as an electric forklift to unload and move the equipment to the place closest to the installation site. When using an electric forklift, insert the tines of the forklift below the bottom pallet (as shown in Figure 2-1) to prevent the equipment from falling over.



DO NOT attempt to move the UPS by the brackets.

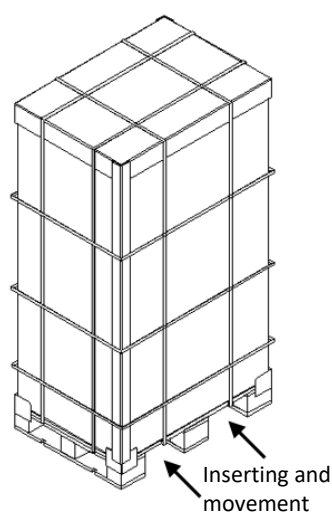

Figure 2-1 Inserting and Movement























2.3 Tools



1. In the interests of safety, the installation tools under live operation must be insulated.

2. Tools in Table 2-1 are for reference only; please comply with the actual installation and connection requirements on-site.

Table 2-1 Tools

Name	Drawing	Name	Drawing
Electric hand drill		Adjustable wrench	
Slotted screwdriver		Cross head screwdriver	
Stepladder		Forklift	
Drill		Wire cutting plier	
Claw hammer		Diagonal cutting plier	
Insulating shoes		Antistatic gloves	
Electrician knife		Cable tie	
Insulating tape		Insulating gloves	
Crimping plier		Heat shrinkable tube	
Insulated torque wrench		Torque screwdriver	
Multimeter		Clip-on ammeter	

2.4 Unpacking

Unpack the UPS and battery packages under the guidance of authorized service engineer.

Steps:

1. Use a cutting plier to cut the packing belt, and remove the honeycomb board as shown in Figure 2-2.

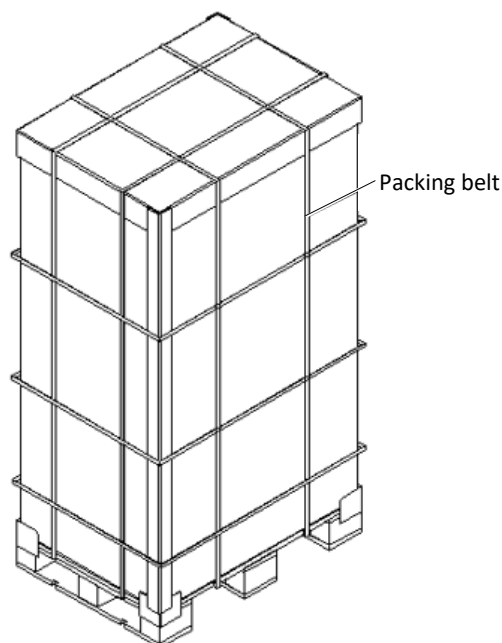

Figure 2-2 Removing packing belt and honeycomb board

2. Remove the carton (I, II, III), wrapping film, and protective cardboard at four corners, as shown in Figure 2-3.

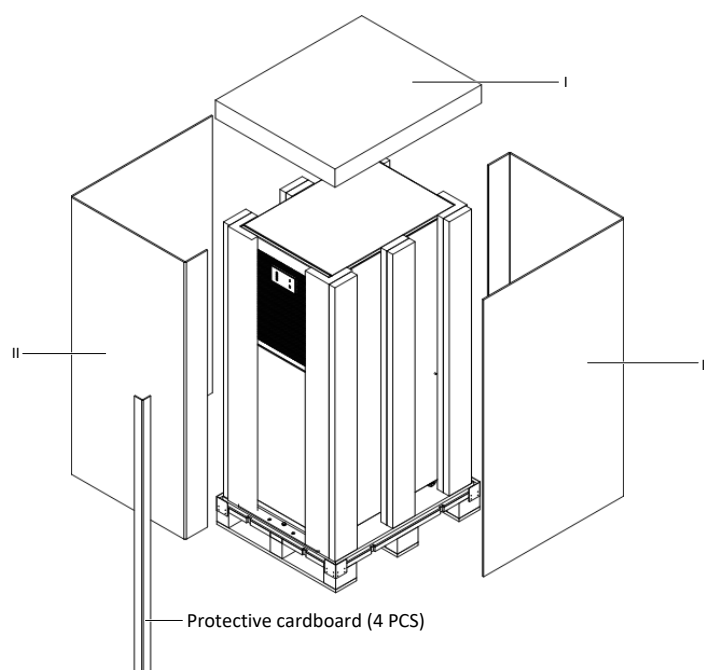

Figure 2-3 Removing Protective Cardboard

3. Open the front panel of the built-in battery compartment, loosen the fixing screws and remove the fixed bottom part from the front of the cabinet. Then loosen the fixing screws and remove the fixed bottom part from the rear of the cabinet (see Figure 2-4).

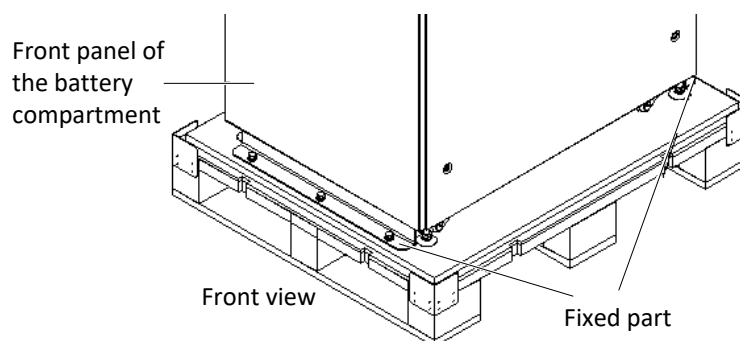

Figure 2-4 Removing bottom fixed part

4. Close the front panel of the built-in battery compartment. Raise the four feet, carry the cabinet using the forklift and move it to its installation position. Then lower the four feet to fix the cabinet.

2.5 Initial Inspection

Before installing the UPS, carry out the following inspections:

1. Ensure that the UPS equipment room environment meets the environmental requirements specified in the product technical specifications, especially the ambient temperature, ventilation conditions, and the dust situations.
2. Unpack the UPS and battery under the guidance of authorized service engineer. Visually inspect if the UPS and battery have any transportation damage. If there is any damage, report to the carrier immediately.
3. Verify the UPS label and confirm the correctness of the UPS. The UPS label is attached on the rear of the front door. The model, capacity and main parameters of the UPS are marked on the label.

2.6 Environmental Requirements

2.6.1 UPS Room

The UPS should be located in a cool, dry, clean-air indoor environment with adequate ventilation, and should be located on concrete or other nonflammable and flat surfaces. The ambient environment should be free of conductive powder (such as metallic powder, sulfide, sulfur dioxide, graphite, carbon fiber, conductive fiber, etc.), acid mist or other conductive media (strongly ionized substances). The environment specifications should comply with relevant international standard & specifications and the operating range specified in this manual.

The UPS uses forced cooling by internal fans. Cooling air enters the UPS through the ventilation grills at the front of the cabinet and exhausted through the ventilation grills at the back of the cabinet. Do not obstruct the ventilation holes (ventilation grills). The front and rear of the UPS should be kept at a distance at least 200mm (see Figure 2-5) from the wall to avoid blocking the UPS heat dissipation, thus reducing the UPS internal temperature and improving the UPS life.

If necessary, install indoor extractor fans to aid cooling-air flow to avoid room temperature buildup. Air filters (optional) should be used when the UPS is to operate in a dirty environment.

2.6.2 Reserved Space

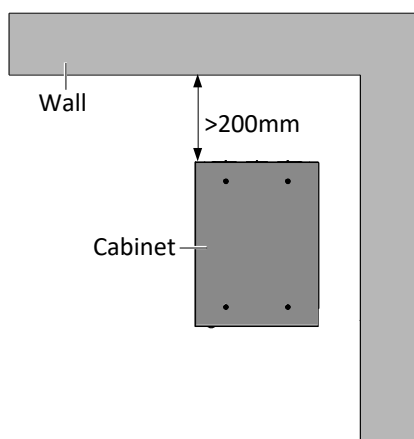

Figure 2-5 Installation clearances (top view)



1. The UPS should only be installed on concrete or other non-inflammable surfaces.
2. The clearance between the rear panel of the wall should be convenient, as shown in Figure 2-5. The clearance should not be less than 200mm and sufficient to permit maintenance operations.
3. When the battery cabinet is installed near the UPS, the maximum allowable ambient temperature is dependent on the battery rather than the UPS.
4. If the UPS is working in ECO mode, the power consumption will be lower than that in Normal mode. Proper air conditioning system shall be selected according to the normal operating mode.

2.6.3 Battery Room

Batteries generate some amount of hydrogen and oxygen at the end of charge, so the fresh air volume of the battery installation environment must meet the EN50272-2001 requirements.

The ambient temperature is the main factor that affects the battery capacity and life. The normal battery operating temperature is 20°C. If the ambient temperature is higher than 20°C, the battery life will be reduced. If it is lower than 20°C, the battery capacity will be reduced. In normal situation, the allowable ambient temperature for the battery is between 15°C to 25°C. The ambient temperature of the battery shall be maintained constant, and the battery shall be kept away from heat source and air outlet.

When the UPS uses an external battery, you must install a protection device (such as fuse or circuit breaker) close to the battery and keep the wiring distance between the battery and the protection device to a minimum.

2.6.4 Storage Environment

If the UPS is not installed immediately, it must be stored with the original packaging in a room for protection against excessive humidity and heat sources. The battery needs to be stored in a dry and cool place with good ventilation. The most suitable storage temperature ranges from 20°C to 25°C.



During the storage period, the battery must be charged at regular intervals, in accordance with the battery instructions. When charging the battery, you can temporarily connect the UPS to the mains to charge the battery and activate it.

2.7 Mechanical Requirements

2.7.1 Moving Cabinet



1. *The lifting equipment for moving the UPS cabinet must have enough lift capacity. Refer to Table 10-3 for its weight.*
2. *Due to its intensity, the castor may not be valid on the uneven surface.*
3. *The center of gravity of the UPS cabinet is high; avoid falling over during the cabinet movement.*
4. *Vertical hanging of cabinet is not allowed.*



When carrying the UPS with built-in batteries, you must independently fasten each battery string and keep the moving distance to a minimum.

2.7.2 Clearance

Since the UPS does not have grille on either side, there are no special clearance requirements on both sides. In addition to the local regulations, it is recommended that clearance around the front of the UPS should maintain a clearance of at least 1200 mm to allow routine tightening of the power terminals within the UPS.

2.7.3 Cable Access Mode

For further description, refer to 3.1.8 *Power Cable Connection Steps* and 3.2. *Wiring of Signal Cable*.

2.8 Installation Drawings

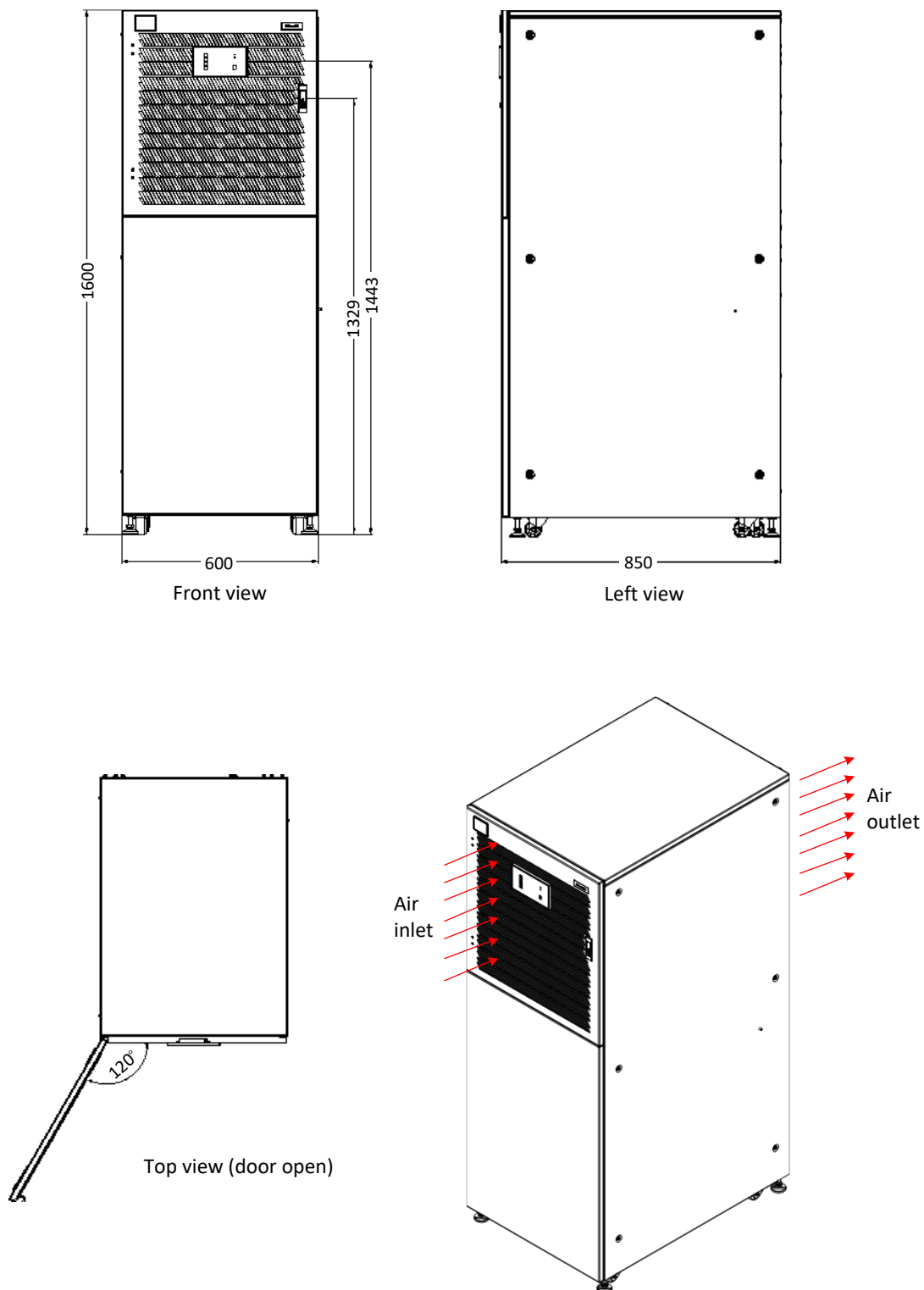

Figure 2-6 Top/front/side/bottom view of the 60kVA UPS (unit: mm)

3 Electrical Installation

This chapter mainly introduces the electrical installation of the UPS, including the power cable and signal cable connecting procedures and methods.

After completing the mechanical installation of the UPS, it is required to connect the power cable and signal cable of the UPS. All the signal cables, whether shielded or not, shall be kept away from the power cables.



1. Do not power on the UPS before the arrival of authorized service engineer.

2. In accordance with the information contained in this chapter, UPS cables should be routed by an authorized engineer.

3.1 Wiring of Power Cable

3.1.1 System Configuration

The cable size of the system power cable shall meet the following requirements:

UPS input cable

The cable size of the UPS input cable differs from the UPS power ratings and input AC voltages, provided that it meets the requirement of maximum input current, including the maximum battery charge current, see Table 3-1.

UPS bypass and output cable

The cable size of the UPS bypass and output cable differs from the UPS power rating and output AC voltages, provided that it meets the requirement of nominal output or bypass current, as shown in Table 3-1.

Battery cable

Each UPS connects to its battery through the three cables connecting to the positive pole, negative pole and neutral line. The cable size of the battery cable differs from the UPS power ratings, provided that it meets the battery discharge current requirement when the battery discharges to near EOD voltage, as shown in Table 3-1.

3.1.2 Maximum Steady State AC and DC Currents

The power cable must be selected accordance with the current and voltage values in Table 3-1 and the local wiring regulations and take environmental conditions (temperature and physical media) into consideration, then refer to *Table 3B* in IEC 60950-1.

Table 3-1 Max. steady state AC and DC currents

UPS power (kVA)	Rated current (A)				Stud bolt/nut specification		
	Max. input current ¹	Output/bypass current ² at full load			Battery discharge current (+, -, N) at min. battery voltage ³	Input/battery/output/bypass/PE cable	Recommended torque (N.m)
		380V	400V	415V			
60kVA	121	91	87	83	208 (2*32-block); 166 (1*40-block)	M8	4.5±5%



1. Max. input current is calculated according to the low-voltage input of 176V, 100% load percentage and 94% efficiency.
2. Max. output/bypass current is calculated according to the rated voltage, 100% load percentage and 94% efficiency.
3. The battery discharge current at the lowest battery voltage is calculated according to the battery cell number of 2*32 and 1*40, and lowest EOD voltage of 1.6V, 100% load percentage and 94% efficiency.

3.1.3 Recommended CSA Of UPS Cable

The recommended CSA of the UPS cable is listed in Table 3-2.

Table 3-2 Recommended CSA of the UPS cable (unit: mm², ambient temperature: 35°C)

Model	Input	Output	Bypass	Neutral line	Earth cable	Battery
60kVA	35	25	25	25*2	16	70



1. If the user's cable CSA exceeds the value recommended in Table 3-2, or the harder cable installation is difficult, please contact Vertiv service engineers.
2. The soft cable with multi-core is recommended for convenient wiring and installation.

3.1.4 Selection of UPS I/O Switch

Table 3-3 is the recommended UPS I/O switch capacity, and the user can select it according to actual needs.

Table 3-3 Recommended UPS I/O switch capacity

Model	Rectifier input switch	Bypass input switch	Output switch	Maintenance bypass switch
60kVA	125A (3P), MCB(C-type)	125A (3P), MCB(C-type)	100A (4P), isolating switch	100A (3P), isolating switch

3.1.5 Power Cable Connecting Terminal

The rectifier input, bypass input, output and battery power cables are connected to the corresponding terminals shown in Figure 3-1.

3.1.6 Protection Ground

The protective earth cable is reliably connected to the PE input terminal (see Figure 3-1) via the fixing bolt. The PE terminal provides several holes for connecting input PE cable, output PE cable, and external battery PE cable.

All the cabinets and cable troughs shall be grounded in accordance with local regulations. The grounding wires shall be securely tied to prevent the loosening of the grounding wire tightening screws when the grounding wires are pulled.



Failure to ground as required may cause EMI, electric shock or fire risk.

3.1.7 Notes

The following points are only for general guidance. If there are relevant local regulations, the local regulations shall prevail.

1. The cable size of the protective earth cable shall be selected according to the AC power failure level, cable length and protection type. The grounding wire connection must use the shortest connection route.
2. For the cables with large current, small cables can be connected in parallel to facilitate installation.
3. When selecting the battery cable size, the current value in Table 3-1 shall be referred to, and a maximum voltage drop of 4Vdc is allowed.
4. Do not form coils, so that the EMI formation is minimized.

3.1.8 Power Cable Connection Steps

Connection terminal and cable routing method

Figure 3-1 shows the connection terminals, power cable entry and UPS power cable routing methods.



Selecting internal battery and external battery at the same time is prohibited.



1. The power cables should be connected firmly and correctly.
2. Add wire guard to the power cable to avoid unexpected damage.
3. When routing the cables inside the cabinets, it is required to bind and fix the cables in the cabinets, so as to prevent cable damage due to mechanical stress.

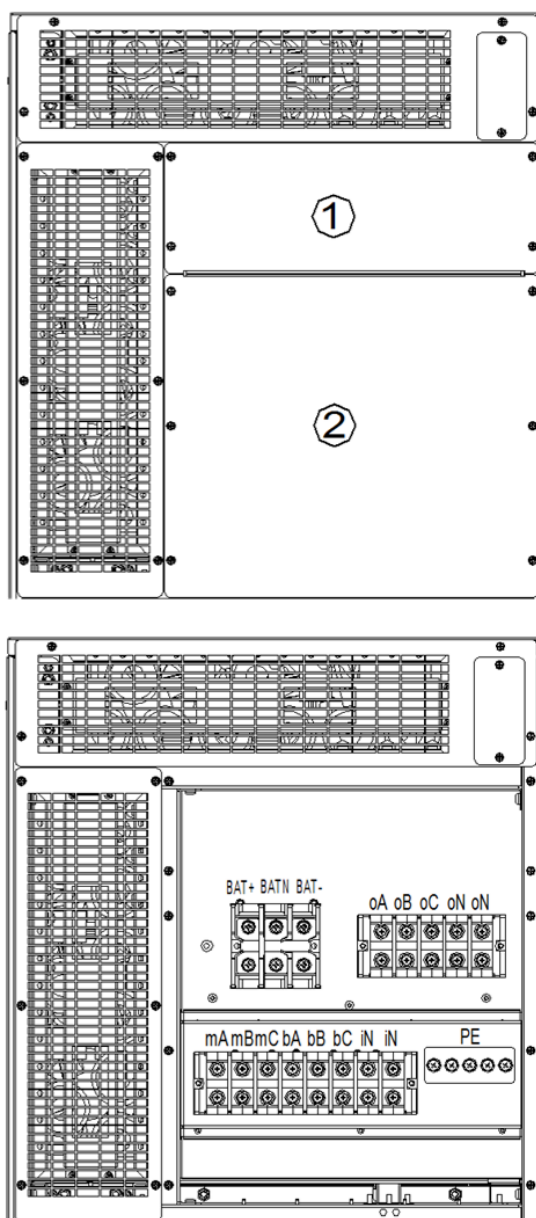

Figure 3-1 Connection terminals and routing method of power cables

Procedures:

1. Two protective covers exist at the rear of the cabinet. The user can process a cabling hole on the No.1 protective cover for routing the cables according to actual needs.

Note: The guard ring or flange must be installed around the cabling hole so that the cables are not cut.

2. Dismantle the No.2 protective cover.

3. In split bypass configuration, just lead the main input cables (mA, mB, mC, iN, PE), bypass input cables (bA, bB, bC, iN, PE), and output cables (oA, oB, oC, oN, PE) into the cabinet through corresponding cabling hole. Refer *Figure 3-1* to connect power cables to corresponding terminals and fix PE cable to PE terminal. In common input configuration, just lead the main input cables (mA, mB, mC, iN, PE), and output cables (oA, oB, oC, oN, PE) into the cabinet through corresponding cabling hole.

4. If the user adopts external battery, just lead the battery cables into the cabinet through the reserved cabling hole at top of the routing area. Refer *Figure 3-1* to connect power cables to corresponding terminals and fix PE cable to PE terminal.

To avoid unexpected damage, add wire guard to the power cable. Refer *Table 3-1* for torque value.

5. After confirming that the cable connection is firm and correct, reinstall the two protective covers at rear of the cabinet.

Now, the connection of power cables is complete.



Before cables connection, ensure that all external and internal power switches of the UPS are off, and post necessary warning signs to prevent inadvertent operation of the switches. Meanwhile, measure the voltages between the UPS terminals and the voltages between the terminals and the earth.



1. The earth cables and neutral line must be connected in accordance with local and national codes of practice.

2. Failure to observe this could result in electric shock or fire risk.

Power distribution mode

Two modes are available for I/O cables: 3-in 3-out, common input configuration (default), 3-in 3-out, split bypass configuration.

Connection of system input

1. 3-in 3-out, common input configuration (default)

The common input configuration comes as a standard by default before delivery. Connect the input cables to the mains input terminals (mA-mB-mC-iN) as shown in Figure 3-1. Ensure correct phase rotation.

2. 3-in 3-out, split bypass configuration

Remove the bypass input cables (bA-bB-bC) connected to the main input terminal. Connect the bypass input cables to the bypass input terminal (bA-bB-bC). Ensure correct phase rotation. Make sure that the main input cables ((mA-mB-mC) are connected to the main input terminal correctly and reliably.

Connection of system output

Connect the system output cables between the output terminals (oA-oB-oC-oN) in the cabinet and the load. Refer to *Table 3-1 for the torque value*. Ensure correct phase rotation.



If there is no requirement of power supply for the load before arrival of the service engineer, ensure that the system output cables are safely isolated at their ends.

Connection of batteries

If external batteries are required, ensure correct polarity of the connections from the battery string terminals to the BCB and from the BCB to the battery input terminals (BAT+, BAT N, BAT-) in the UPS cabinet (see Figure 3-1), i.e., (+) to (BAT+) and (-) to (BAT-), (N) to (BAT N), and disconnect one or more battery cell links in each tier. Do not reconnect these links and do not close the BCB before authorized to do so by the service engineer.



When connecting the cables between external battery terminals and BCB, the connection should begin from the BCB terminal.

If the user selects internal batteries, please wear arc protective gloves to connect battery input terminals (+ red, N blue, -black), as shown in Figure 3-2.

Procedures:

- 1. Open the cabinet front door, remove the battery compartment board.*
- 2. Wear arc protective gloves to connect battery input terminals (+, N, -).*
- 3. Check that the connection is correct, and then reinstall the battery compartment board.*



1. When connecting the battery terminals, you must wear arc protective gloves to avoid arc damage.
2. You must connect the battery terminals according to their colors. Failure to do so can lead to battery short circuit and accident.
3. The battery terminals must be connected firmly.
4. You can operate battery terminals connection only before the UPS power-on.



Figure 3-2 Connecting battery internal terminals

3.2 Wiring of Signal Cable



1. Respectively route the power cables and signal cables. The shielding coat of signal cable must be reliably earthed.
2. Refer to 7.2 Connecting Dry Contact Port Cables for the definition of signal cables.

Top cable access is available for signal cable. Refer to Figure 3-3 for wiring of signal cable.

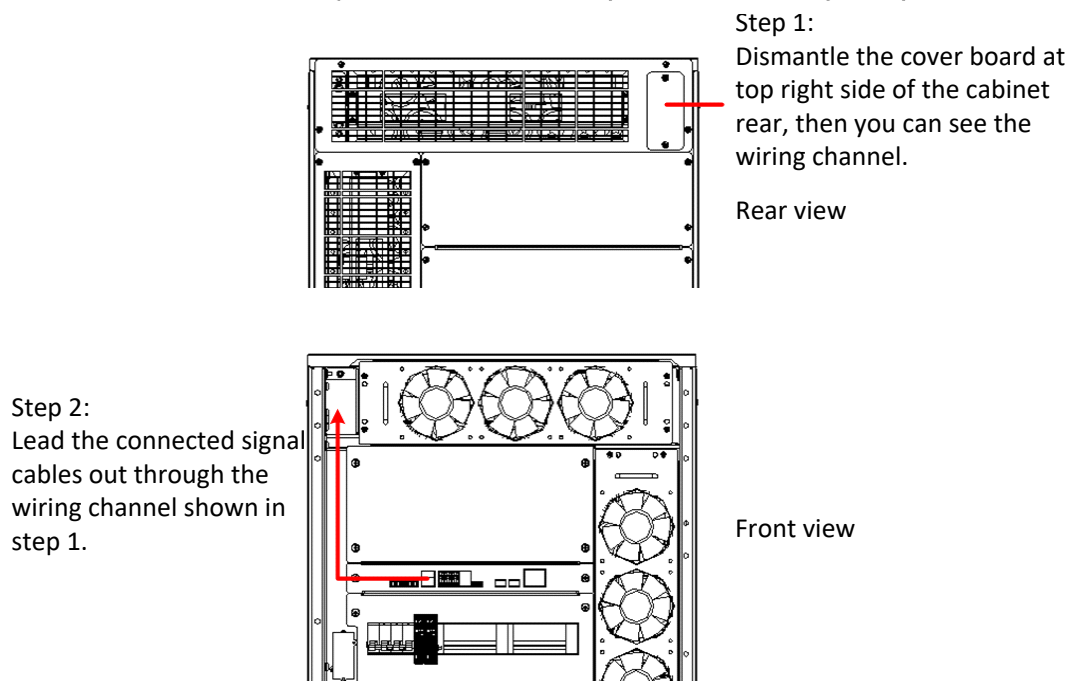

Figure 3-3 Wiring of signal cables (top cable access)

4 Operator Control and Display Panel

This chapter introduces the functions and use of the components on the UPS operation and display panel, and provides LCD display information, including the different landing pages, detailed menu messages, prompt windows message, and UPS alarm list.

4.1 Introduction

The operator & display panel is located on the front panel of the UPS. The operator & display panel allows the user to operate and monitor the UPS, and view the UPS parameters, UPS and battery status information and any alarm messages. As shown in Figure 4-1, the operator & display panel includes an LCD screen, menu keys, and LED indicators (run indicator and alarm indicator)

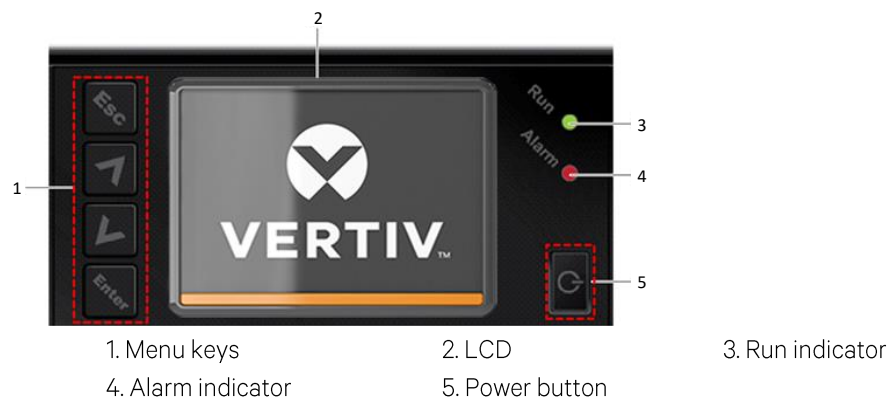

Figure 4-1 Operation and display panel

4.1.2 LED Indicators

The LED indicators consist of the run indicator and alarm indicator. Table 4-1 provides a description of these indicators.

Table 4-1 Description of LED indicators

Indicator	Color	State	Meaning
Run indicator	Green	On	UPS output voltage at each phase side is larger than or equal to 60V
		Off	UPS output voltage at 3-phase side is smaller than 60V
Alarm indicator	Yellow	On	Alarm active
	Red	On	Fault present
	/	Off	No alarms, no faults

4.1.3 Audible Alarm (Buzzer)

UPS operation is accompanied with the following two different kinds of audible alarms, as described in Table 4-2.





Table 4-2 Description of Audible Alarm

Sound	Meaning
Continuous beep	This sound is generated in the event of a UPS fault condition, such as a fuse or hardware failure.
One beep every 3.3 second	This sound is generated in the event of a general UPS alarm condition.

4.1.4 LCD And Functional Keys

The operator & display panel includes five function keys, the respective functions are described in Table 4-3.

Table 4-3 Description of control buttons

Functional key	Silkprint	Description
Confirm		Used to confirm or enter
Up		Used to scroll up, scroll left or increase value, etc.
Down		Used to scroll down, scroll right or reduce value, etc.
Escape		Used to go back, exit, cancel or forbid operation
Power		Used to switch on, switch off or transfer to Bypass mode

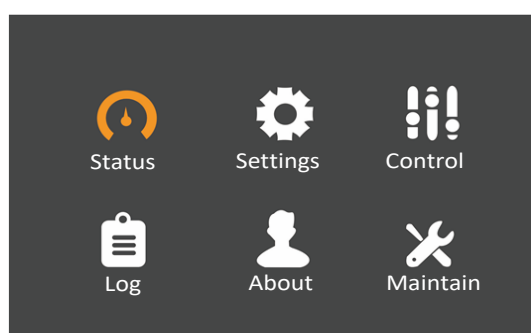

Figure 4-2 LCD screen

The LCD includes a user-friendly interface and a 320 × 240 dot matrix image display. Thanks to the user-friendly, menu-oriented LCD, it is possible to browse easily through the UPS input, output, load, and battery parameters, obtain information about the current UPS status and alarm messages, as well as perform functional setting and control operations.

The LCD also stores historical alarm records that can be retrieved for reference and diagnosis.

4.1.5 LCD Menu Structure

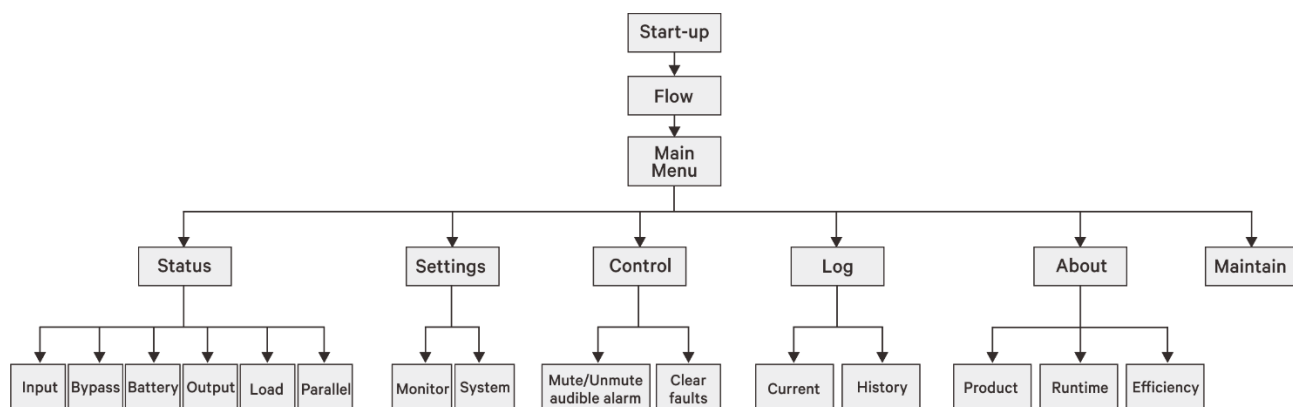

Figure 4-3 LCD Menu Structure

4.2 LCD Screen Types

4.2.1 Start-up Screen

When the UPS is started, it performs a system self-test that displays the Start-up screen for approximately 10 seconds, as shown in Figure 4-4.



Figure 4-4 Start-up Screen

4.2.2 Flow Screen

Once the UPS self-test is complete, the flow screen as shown in Figure 4-5 is displayed.

The flow screen provides a total overview of the UPS status, including the input, bypass, rectifier, battery, inverter and output, etc. Operating modes are displayed in color, while invalid is displayed in grey.

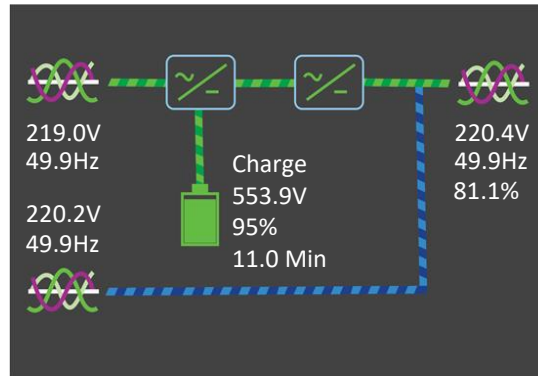

Figure 4-5 Flow Screen

Press the key on the flow page to access the main menu screen.

4.2.3 Main Menu Screen

The main menu screen consists of six icons: Status, Settings, Control, Log, About, Maintain (see Figure 4-6).

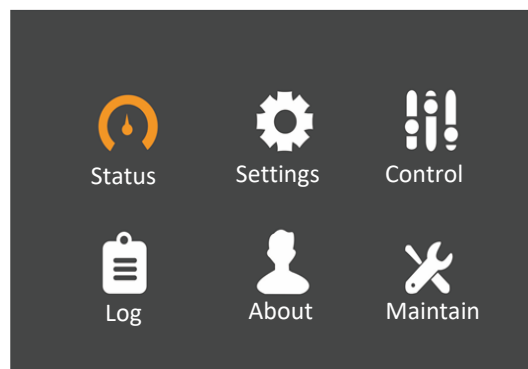

Figure 4-6 Main menu screen

Press the key on the main menu screen to return to the flow screen. Press the or key to switch the cursor to select the required submenu, then press the key to confirm it.

4.2.4 Submenu Screen

The submenu screen contains the UPS parameters and item settings.

After accessing the submenu screen, move the cursor to the tab if there is a tab control. At this point, you can press the **▲** or **▼** key to switch the tab. Press the **Enter** key to move the cursor to a specific item.

After accessing the submenu screen, if there is no tab control, the cursor will stop on a specific item.

Press the **Esc** key to return to the previous screen.

For more details about the submenu screen, see following pages.

Status page

The Status page contains information about the Input, Bypass, Battery, Output and Load.

See below:

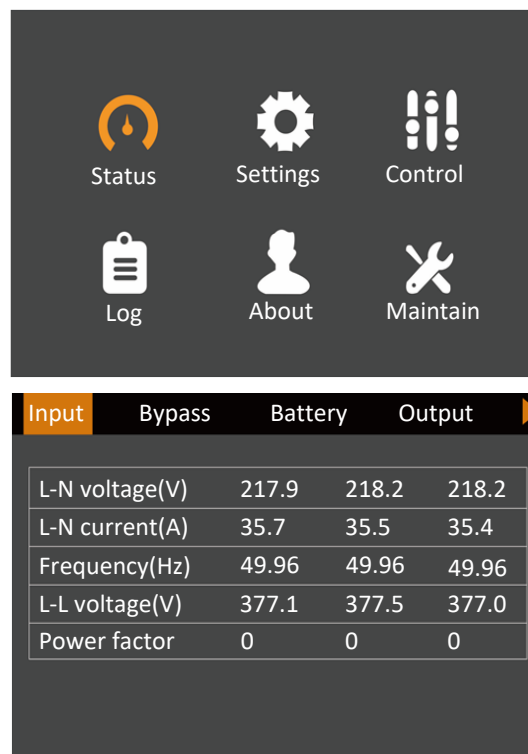

Input	Bypass	Battery	Output
L-N voltage(V)	220.0	220.2	220.8
Frequency(Hz)	50.00	50.00	50.00
L-L voltage(V)	381.2	381.9	381.7

Input	Bypass	Battery	Output
Battery status	Float		
Battery voltage(V)	270.5	283.2	
Battery current(A)	0.67	0.86	
Backup time(Minut...)	195		
Remaining capacit...	95.7		

Input	Bypass	Battery	Output
L-N voltage(V)	219.8	220.4	220.4
L-N current(A)	36.0	36.4	36.0
Frequency(Hz)	49.97	49.97	49.97
L-L voltage(V)	381.2	381.7	381.2

Load			
Sout(kVA)	8.0	8.0	8.0
Pout(kW)	7.7	7.8	7.8
Qout(kVAR)	2.1	1.7	1.7
Power factor	0.96	0.97	0.97
Crest factor	1.4	1.4	1.4
Load percent(%)	80.9	80.9	79.9

Settings page

The Settings page is used to access the Monitor and System settings.

See below:

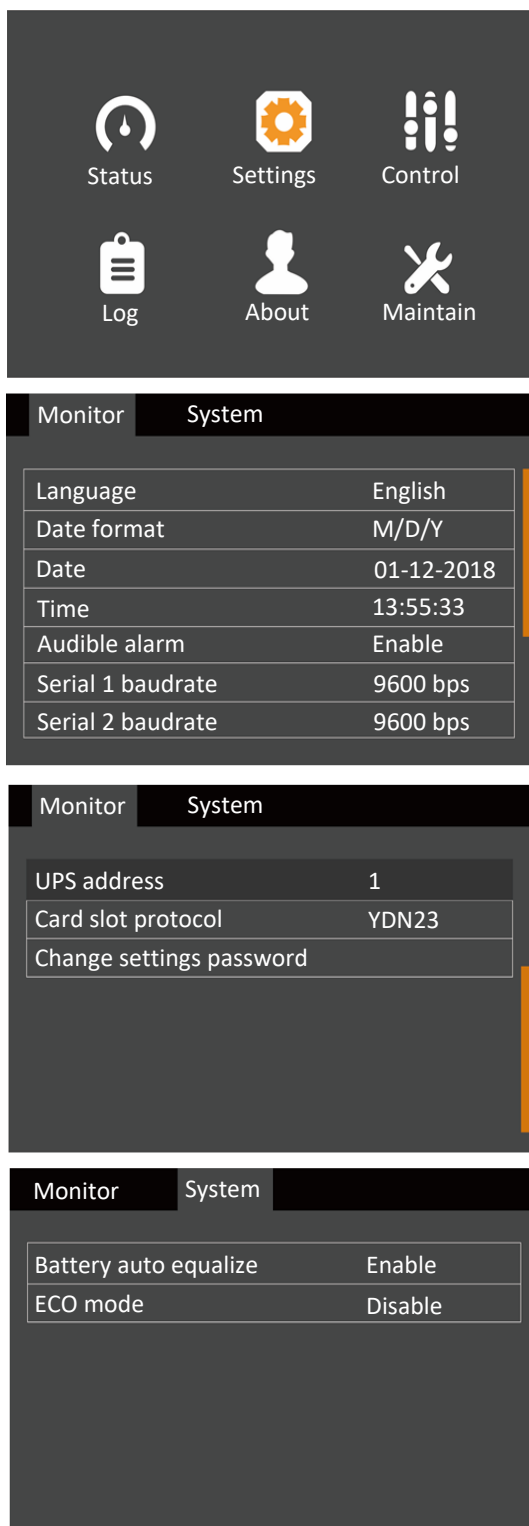

The Settings page features a navigation menu with the following options:

- Status
- Settings
- Control
- Log
- About
- Maintain

The Settings page is divided into two main sections: Monitor and System. The System section is currently active and displays the following configuration options:

System	
Language	English
Date format	M/D/Y
Date	01-12-2018
Time	13:55:33
Audible alarm	Enable
Serial 1 baudrate	9600 bps
Serial 2 baudrate	9600 bps

The Monitor section is currently inactive and displays the following configuration options:

Monitor	
UPS address	1
Card slot protocol	YDN23
Change settings password	

The System section is currently active and displays the following configuration options:

System	
Battery auto equalize	Enable
ECO mode	Disable

Control page

The Control page is used to access the Clear faults, Mute/Unmute audible alarm, etc. functions. See below:

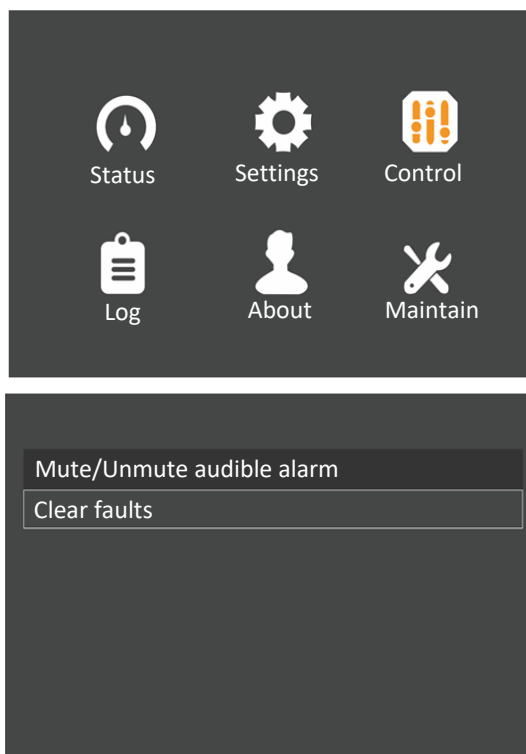

Log page

The Log page is used to access a list of current and historical UPS events. See below:

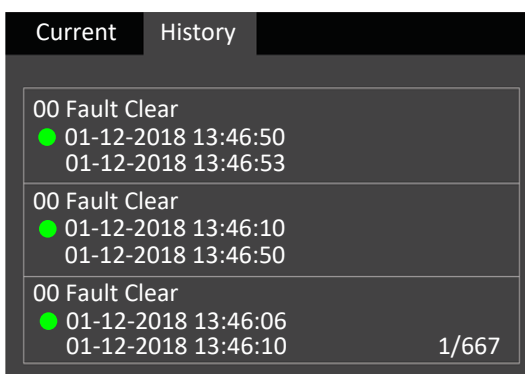
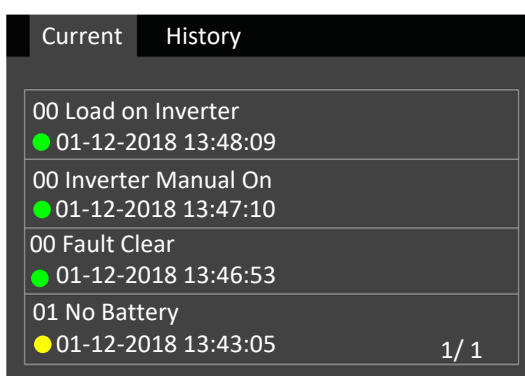
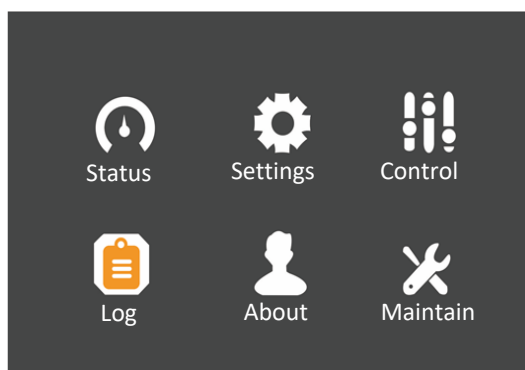

About page

The About page contains information about the Product, Run time, and Efficiency. See below:

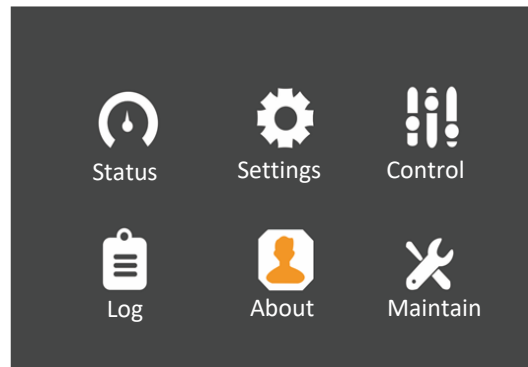

Product	Run time	Efficiency
Product type	380V-50Hz-EXS	
Serial number	1230000000000...	
Monitor APP version	V000B012D000	
Monitor Bootloader...	V000B003D000	
Monitor Resource ve...	V000B007D000	
1# Rectifier DSP ve...	V000B009D000	
1# Inverter DSP ver...	V000B010D000	

Product	Run time	Efficiency
UPS run time	04Day 17Hour 5...	
Bypass run time	01Day 06Hour 1...	
DCBus capacitance...	01Day 19Hour 1...	
Suspended time rem...	Unknown	
Battery discharge t...	00Day 11Hour 2...	
Battery discharge c...	211	

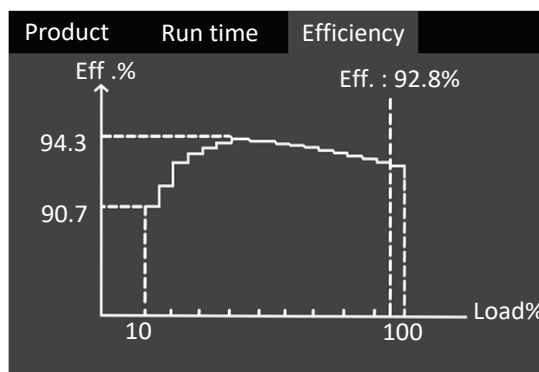

Maintain page



The Maintain page is password protected (12345) and reserved for use by Vertiv service engineers only.

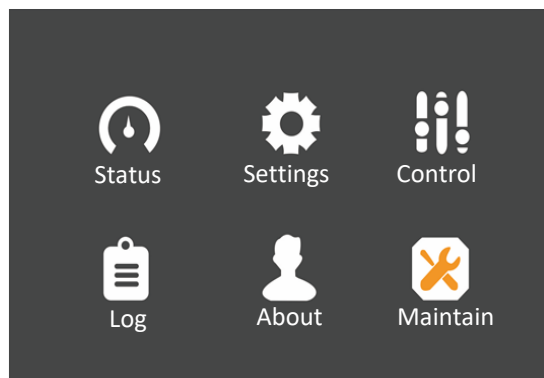

4.2.5 Default Screen

During the UPS operation, if there are no alarms for two minutes, the display will return to its default as shown in Figure 4-7. While the Default screen is displayed, if there are no alarm or fault conditions active, the Flow screen, shown in Figure 4-5 is displayed if the user presses any key.



Figure 4-7 Default screen

4.3 Prompt Window

When the system is in operation, a prompt window is displayed to alert about certain conditions and/or request to confirm a command or other operation. Table 4-4 lists the prompts and the associated meanings.

Table 4-4 Prompts and Meanings

Prompt	Meaning
Incorrect password, please input again	This prompt appears when the user enters an incorrect Settings password
Operation failed, condition is not met	This prompt appears when the user attempts to execute a certain operation, but the necessary condition is not met
Password changed OK	This prompt appears when the user has changed the Settings password successfully
Fail to change password, please try again	This prompt appears when the user attempts to change the Settings password but has failed to use the same new password twice
Turn on failed, condition is not met	This prompt appears when the user presses the power button (or executes the 'Turn on/Turn off/to Bypass' command on the 'Control' page)
Battery test abort, condition is not met	The battery self-test condition is not met. The user should verify that the battery is in boost charge mode and the load capacity is larger than 20%
Equalize charge failed, Condition is not met	This prompt appears when you select the Freshening charge command while the battery freshening charge condition (such as no battery, charger failure) is not met
Turn on more UPS to carry current load	The number of inverters already turned on is insufficient to carry the existing load. The user is required to turn on more UPSs
The load is too high to be transferred with interrupt	The total load must be less than the capacity of one UPS to allow a parallel system to perform an interrupted transfer from bypass to inverter
Turn on local INV? OK or Cancel	This prompt appears when you press the power button, confirm or cancel it
Turn off local INV? OK or Cancel	This prompt appears when you press the power button, confirm or cancel it
Stop battery testing? OK or Cancel	This prompt appears when you select a command to stop battery test , confirm or cancel it
New alarm presents, Show log? OK or Cancel	This prompt appears when there is a new alarm generated, confirm or cancel it
Start equalize charge? OK or Cancel	This prompt appears when you select a command of freshening charge, confirm or cancel it
Stop equalize charge? OK or Cancel	This prompt appears when you select a command to stop freshening charge, confirm or cancel it
Clear faults? OK or Cancel	This prompt appears when you select a command of fault clear, confirm or cancel it
Battery reset? OK or Cancel	This prompt appears when you select a command of battery restore, confirm or cancel it
Start capacity test? OK or Cancel	This prompt appears when you select a command of battery capacity test, confirm or cancel it
Start maintaining test? OK or Cancel	This prompt appears when you select a command of battery maintenance test, confirm or cancel it

Prompt	Meaning
Xfer to normal mode, start maintaining test?	This prompt appears when you select a command of battery maintenance test during the system works in ECO mode, confirm or cancel it
Xfer to normal mode, Start capacity test? OK or Cancel	This prompt appears when you select a command of battery capacity test during the system works in ECO mode, confirm or cancel it
Transfer with interrupt, OK or Cancel	Inverter and Bypass supplies are not synchronized and any load transfer between the supplies will cause a brief load interruption
This operation leads to output shutdown, OK or Cancel	No alternative supply is available and any Inverter Off operation will cause the load to be de-energised
This operation leads to inverter overload, OK or Cancel	Turning off this inverter will lead to the overload of remaining inverter(s) in a parallel system
Turn on local INV Turn on PARA INV	This prompt appears when you press the power button, select one
Turn off local INV Turn off PARA INV	This prompt appears when you press the power button, select one
History log exporting...	The Paramset is exporting the historical log
Please confirm Local INV is off	This prompt appears when maintenance mode guide starts, please confirm it
Please confirm PARA INV is off	
Please confirm Int MBB is closed	
Please confirm Int MBB and EXT MBB are closed	
Please confirm Int MIB is opened	
Please confirm Int MIB and EXT MIB are opened	
Please confirm EPO is active	
Please confirm RIB is opened	
Please confirm BIB is opened	
Please confirm BIB is closed	
Please confirm RIB is closed	
Please confirm EPO is cleared	
Please confirm Int MIB is closed	
Please confirm Int MIB and EXT MIB are closed	
Please confirm MBB is opened	
Please confirm Int MBB and EXT MBB are opened	
Please confirm PARA INV is on	
Please confirm Local INV is on	

4.4 UPS Alarm Message List

Table 4-5, Table 4-6 and Table 4-7 list all the UPS alarm messages based on the 'Current' and 'History' menus.

Table 4-5 UPS Alarm Message List

Alarm	Meaning
Input Phase Reversed	The AC input phase rotation is reversed
Input Voltage Abnormal	The mains voltage is outside specifications and results in rectifier shutdown
Input Frequency Abnormal	The mains frequency is outside specifications and results in rectifier shutdown
Input Undervoltage	At least one phase main input voltage is within 132V~176V, thus the load should be derated
Excess Auto Retransfers	The load remains on bypass power owing to excessive number of transfers that occurred within one hour
Excess ECO Auto Transfers	The load remains on inverter power owing to excessive number of transfers that occurred within one hour
Calibration Shutdown	For tower-type UPS calibration, select the module to be calibrated via the host software. Shutdown for the modules not to be calibrated, and 'Calibration Shutdown' alarm generated
Load Sharing Abnormal	The UPSs in a parallel system are not sharing the load current correctly
Inverter Asynchronous	The output voltage and bypass voltage are misaligned in phase. This alarm resets automatically once the condition is no longer true
Overvoltage N-GND	Neutral to ground voltage is too high. Check whether the output cable is shorted to the enclosure or not
Bypass Abnormal	The amplitude or frequency of the bypass voltage exceeds the limit
Bypass Phase Reversed	The phase rotation of the bypass voltage is reversed
Bypass Unable to Trace	The bypass voltage and frequency are outside specifications
Bypass Overcurrent	The bypass current is outside the rated current of 1.1 times
Bypass Not Available	Bypass output disabled under generator mode
Bypass Overcurrent Timeout	Bypass overload delay timeout, and the bypass shuts down
Battery Reversed	Reconnect battery and check battery wiring
No Battery	Check the battery fuse, battery and battery connection
Battery Overtemperature	Battery ambient temperature is too high. Check whether the battery ambient temperature is higher than settings value (40°C by default, settable range: 25-60°C)
Battery Maintain	Start the battery maintenance discharge test
BCB Open	BCB is opened

Alarm	Meaning
Battery terminal short	Check the battery wiring, battery and cabinet port, and battery fuse to verify whether there is short circuit or arc
Battery Voltage High	After connecting the battery, the system measures that the battery voltage exceeds high voltage range. Please check whether the battery terminal voltage exceeds normal range
Output Overload	This alarm will appear when the module load exceeds 105% of the rated value. This alarm resets automatically once the load declines to 95% of rated value
Equalize Charge Timeout	The actual float charging time exceeds the time set by the setting software
Battery Test Fail	The battery self-test condition is not met. The user should verify that the battery is in boost charge mode and the load capacity is larger than 20%
MonCAN Comms. Abnormal	Communication failure among internal monitoring board and inverter, rectifier and bypass
PowerCAN Comms. Abnormal	Internal communication among the inverter, rectifier and bypass gets a failure
Discrete Bus Comms. Abnormal	Communication failure between discrete bus inside the rack. It is recommended to confirm that the rear communication cables connection inside the rack is reliable
Ambient Overtemperature	Ambient overtemperature detection, can be set via the host software
Fan Abnormal	At least one fan has fault
External MIB Open	The external maintenance isolating switch is opened
Internal MBB Closed	The maintenance switch is closed
External MBB Closed	The external maintenance switch is closed
Maint Isolation Breaker Open	The output switch is opened
Module Output Breaker Open	The external output switch is opened
Load Shed Signal 1 Active	During the battery discharge, if the back-up time or remaining capacity is insufficient, the load shed signal 1 will be activated
Load Shed Signal 2 Active	During the battery discharge, if the back-up time or remaining capacity is insufficient, the load shed signal 2 will be activated
Loss of Redundancy	Loss of redundant capacity
MMS Capacity Exceeded	When the output load of the N+X parallel system is larger than N, there will be an alarm to prompt that I/O switch and cables are bearing rated power exceeding the specified value
LBS Abnormal	LBS is abnormal
Input Transf. Overtemp.	Input transformer overtemperature
Output Transf. Overtemp.	Output transformer overtemperature

Table 4-6 UPS fault message list

Fault	Meaning
Input Backfeed	Battery voltage fed back to rectifier input. Check that the rectifier SCR is normal
Input Current Abnormal	Battery load sharing imbalance or mains battery frequent transfer more than 5 times within 5min
Input Current Limit	Input current over limit
Input Neutral Missing	AC rectifier input neutral line not detected
Rectifier Fault	Bus voltage abnormal or battery SCR short circuit
Rectifier Soft Start Fail	Owing to low DC bus voltage, the rectifier will report this alarm
Inverter Fault	Inverter output voltage outside specifications. Load transfers to bypass if bypass is available
DC Bus Abnormal Shutdown	DC bus voltage outside specifications. Load transfers to bypass if bypass is available
DC Bus Overvoltage	DC bus overvoltage makes rectifier, inverter and battery converter shut down. Load transfers to bypass if bypass is available
Load Impact Transfer	A transfer to bypass occurred due to a large step load. The UPS can recover automatically. Turn on the load equipment in stages to reduce the load impact on the inverter
Other Module Transfer	All UPSs in the parallel system transfer to bypass at the same time when one of them needs to transfer to bypass. This message appears on the LCD of the UPS with passive transfer to bypass
Bypass Abnormal Shutdown	Both the bypass and inverter voltages are abnormal, and the output is off
Inverter Relay Fail	At least one of the inverter relays is opened or shorted. This fault is locked until mains power-off
Bypass STS Fail	At least one of the STSs at the bypass side is open or shorted. This fault is locked until power-off
Other Bypass STS Fail	The adjacent bypass STS open circuit fault or short-circuit fault
Bypass Backfeed	The bypass back-feed is faulty
Charger Fault	Battery charger has a failure
Low Battery Warning	Before the EOD, battery low pre-warning will occur. After this pre-warning, the battery will have the capacity for 5min discharging with full load. The time is user-settable from 3min to 60min (5min by default)
Battery Ground Fault	Battery has ground fault
BCB Status Abnormal	Logic conflict between BCB drive signal and feedback signal
Discharge Current Limit	Discharge current is over limit, close the discharger
Discharge Fault	Discharger has fault, bus voltage too high or too low during discharger start or soft start, exceeding the setting value
Output Overload Timeout	The UPS overload status continues and the overload times out. When the time has expired, the load automatically transfers to the bypass
Output Fuse Fail	At least one of the inverter output fuses is blown

Fault	Meaning
Output Voltage Abnormal	At least one phase of the output voltages is abnormal
EPO	Dry contact input signal or external EPO command received
Output Disabled	EOD event happened. Check the battery voltage
Control Power Fail	The auxiliary power failure or power-off
Operation Invalid	Maintenance bypass switch is closed when the parallel system is on inverter, or output switch and maintenance bypass switch are closed when the inverter is on
Rectifier DSP SW Error	Rectifier DSP program incorrect, may burn the inverter or bypass DSP
Inverter DSP SW Error	Inverter DSP program incorrect, may burn the rectifier or bypass DSP
Inverter FPGA SW Error	Inverter FPGA program incorrect, may burn the bypass FPGA
Power Hardware Mismatch	The model information set at the host is inconsistent with the actual situation
Parameter Config. Fail	EEPROM operation failed during DSP configuration, or DSP parameter issued by MON failed
Module Overtemperature	The power tubes of rectifier and inverter inside the module have overtemperature
Charger Overtemperature	The power tube of charger inside the module has overtemperature
Pwr. Mod. Unauthorized	The module does not work due to unauthorized power module. Please contact the service center of the manufacturer to get corresponding authority
HMI Unauthorized	The UPS does not work due to unauthorized HMI. Please contact the service center of the manufacturer to get corresponding authority

Table 4-7 UPS Prompt Message List

Prompt	Meaning
Rectifier in Setting	The rectifier starts up and is in synchronization
Inverter in Setting	The inverter starts up and is in synchronization with the monitoring
Battery Reset	The battery state restores to a new one
Battery End of Discharge	Inverter turned off due to battery EOD
BCB Closed	BCB state (closed)
Charger Shutdown	Dry contact signal. When the dry contact gives a command of charger shutdown, then the charger will shut down
Fault Clear	Select the command of 'Clear faults' via the Control page
Silence Active	Select the command of 'Mute/Unmute audible alarm' via the Control page
Silence Inactive	Under conditioner of buzzer silence, select the 'Mute/Unmute audible alarm' command via the Control page
Inverter Manual On	Power button on the operator control and display panel pressed to manually turn on the inverter

Prompt	Meaning
Turn On Fail	When the Inverter Manual On is pressed, the inverter failed to turn on. This may be the result of an invalid operation (maintenance bypass switch closed) or DC bus or rectifier that is not ready
Inverter Manual Off	Power button on the operator control and display panel pressed manually to turn off the inverter
Autostart	After UPS shutdown at EOD, the inverter automatically starts upon mains restoration
Load on Bypass	UPS is in bypass mode
Load on Inverter	UPS is in normal mode
Load on Battery	UPS is in battery mode
Load Off	UPS shut down, both bypass and inverter have no output
Automatic Battery Test	The battery is under automatic periodic battery maintenance discharge test (20% capacity discharge)
Calibrated Battery Test	The user initiates a battery capacity test (100% capacity discharge)
Manual Battery Test	The user initiates a maintenance test (20% capacity discharge)
Rectifier DSP Update	Rectifier DSP software being updated
Inverter DSP Update	Rectifier FPGA software being updated
Inverter FPGA Update	Inverter DSP software being updated
Monitor Update	Inverter FPGA software being updated
Remote Turn On	Turn on the inverter through the service command
Remote Turn On Fail	Caused by invalid operation (maintenance bypass switch closed), DC bus or rectifier not ready
Remote Turn Off	Turn off the inverter through the service command
Flash Operate Fail	Historical record not saved
Battery Equalize Charge	The battery is forced to be in boost charge state
On Generator	Dry contact signal. The system is in generator mode
RIB Open	The input switch is opened
Internal MBB Open	The maintenance switch is opened
External MBB Open	The external maintenance switch is opened
Bypass Input Breaker Open	The bypass switch is opened
System Interrupt Transfer	Execute the interval transfer under conditions of bypass unable to trace and inverter phase not locked
LBS Active	LBS is enabled
Module in Sleeping	The module is in sleep mode and doesn't work. This state can only be presented by the UPS configured with intelligent parallel mode or intelligent ECO demo mode.
Module Comms. Normal	Communication between the module and monitoring is normal

Prompt	Meaning
ECO Mode Enabled	ECO mode enabled
ECO Mode Active	ECO mode activated
Intell. ECO Mode Enabled	Intelligent ECO mode enabled
Intell. ECO Mode Active	Intelligent ECO mode activated
Intell. ECO Mode Demo Enabled	Intelligent ECO demo mode enabled
Intell. ECO Mode Demo Active	Intelligent ECO demo mode activated
Freq. Converter Mode Enabled	Frequency converter mode enabled
Freq. Converter Mode Active	Frequency converter mode activated
IP Mode Enabled	Intelligent parallel mode enabled, that is sleep mode
IP Mode Active	Intelligent parallel mode activated, that is sleep mode
IP Mode Demo Enabled	Intelligent parallel demo mode enabled, that is sleep demo mode
IP Mode Demo Active	Intelligent parallel demo mode activated, that is sleep demo mode
Regen. Mode Enabled	Self-aging mode enabled
Regen. Mode Active	Self-aging mode activated
Testing Mode Enabled	Testing mode enabled
Testing Mode Active	Testing mode activated
Pwr. Conditioner Mode Enabled	Power conditioner mode enabled
Pwr. Conditioner Mode Active	Power conditioner mode activated
MMS Inv. Manual Off	Power button is pressed on one UPS, and select the parallel system for unified shutdown
MMS Inv. Manual On	Power button is pressed on one UPS, and select the parallel system for unified start-up



1. For UPS installed with the optional battery monitor, refer to the battery monitor user manual for the alarm messages related to battery cell and charge current.
2. If the alarm is generated as the result of a software value set-up by Vertiv engineer, and you wish to modify the setting, please get in touch with your local Vertiv customer service center.

5 UPS Operating Instructions

This chapter introduces the operating precautions and routine operating methods of UPS in detail.

5.1 Brief Introduction

5.1.1 Precautions



The user can conduct relative operation only after the Vertiv engineer carries out the first power on and test.



Hazardous mains and/or battery voltage

1. No operator-serviceable parts are located behind covers that require a tool for their removal. Only qualified service personnel are authorized to remove such covers.

2. The AC/DC input and output terminals of UPS have dangerous voltage at any time. If the cabinet is equipped with an EMC filter, the filter may have dangerous voltage.

1. For the operation keys and LCD related to all the operating steps, refer to *Chapter 4 Operator Control and Display Panel*.
2. During operation, the buzzer alarm may be activated, if so, you can select the command of 'Mute/Unmute audible alarm' via the Control page to silence the audible alarm.
3. When UPS uses traditional lead-acid battery, the system offers boost charge optional function. If the lead-acid battery is used, when the mains returns after prolonged mains failure, the charging voltage of the battery will be higher than the normal charging voltage, this is normal, and the charging voltage of the battery returns to normal value after a few hours of charging.

5.1.2 Power Switch

Opening the front door of the UPS cabinet reveals the power switches, as shown in Figure 5-1, including:

Q1: Rectifier input switch, which connects the UPS to the main circuit power.

Q2: Bypass input switch, which connects the UPS to the bypass.

Q3: Maintenance bypass switch (lockable), which supplies power to the load when UPS is being maintained.



If the UPS system is composed of more than two paralleled UPS modules, do not use the internal maintenance bypass switch.

Q5: Output switch, which connects the UPS output to the load.

QN: N line switch, which connects the UPS N line to the load.

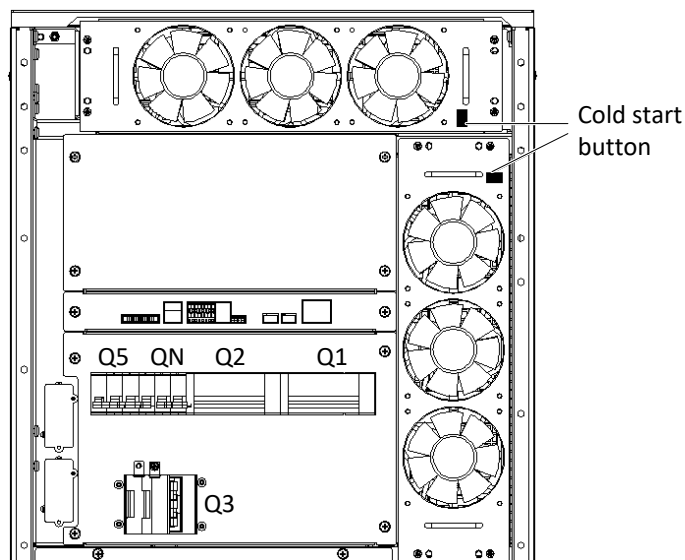

Figure 5-1 UPS power switch

5.1.3 Check Before Start-up

1. Check and confirm that the UPS power distribution mode is correct, the power cables and signal cables are connected correctly, and there are no short circuits.
2. Check that the batteries are properly installed, the cables are correctly connected, and that the positive and negative battery poles are correct.
3. Measure the mains voltage and frequency and verify that they are correct.
4. The UPS output terminals are energized when the UPS is switched on. If the load has already been connected to the output terminals, ensure that it is safe to apply power to it.



The user may only switch the UPS on once the UPS has been installed completely and the authorized service engineer has completed the commissioning tests and shut down the external power input switches.

5.2 UPS Start-up Procedures

The UPS must be completely installed and tested by authorized engineer, and external power supply switch is closed, then you can start the UPS.

5.2.1 Start-up Procedures in Normal Mode



1. To avoid misreporting as faults, all operations related to disconnection or connection of the maintenance bypass switch shall be completed within three seconds.

2. After the output is closed, if any loads are connected to the UPS output terminals, check with the user that it is safe to apply power.

Use the following procedures to switch on the UPS when it is in fully switched off state.

1. Open the front door of the UPS, ensure that the internal maintenance bypass switch Q3 is off, and that the input cables and PE terminals are securely connected.
2. Close the N line switch QN.
3. Close the output switch Q5, bypass input switch Q2 and main input switch Q1 in turn.
4. The system is currently powered on, and the UPS internal cooling fan starts. The rectifier executes self-check and starts to run. The rectifier runs in normal state for approximately 30 seconds, after which the rectifier start-up phase is complete. See Figure 5-2 for power flow page.

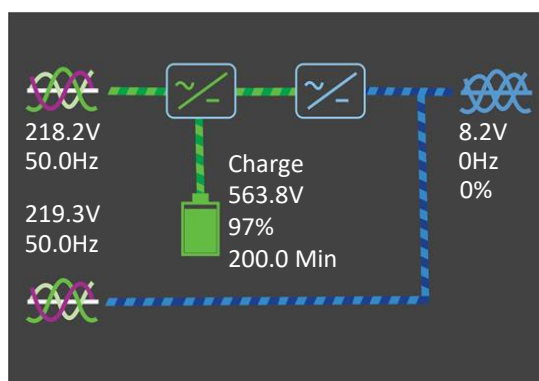

Figure 5-2 Flow Page

5. Finish setting up the single UPS parameters and check them.

Access the main menu screen: press the or key to select 'Status' and press the key to access the interface shown in Figure 5-3.

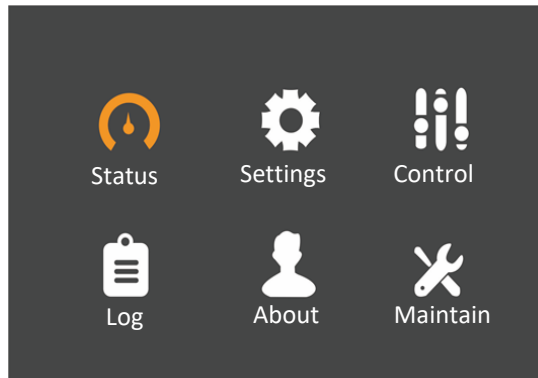

Figure 5-3 Main Menu Screen

Check that the parameters containing input, bypass, battery voltage, frequency and phase are correct, and then go back to the Flow page.

6. Access the flow page: press the power button, and the LCD prompts a dialogue box, as shown in Figure 5-4. After selecting 'YES', the inverter executes self-check and start-up. After the inverter runs normally, the UPS will transfer to normal mode, and the run indicator will be solid on. See Figure 5-5 for the power flow page.

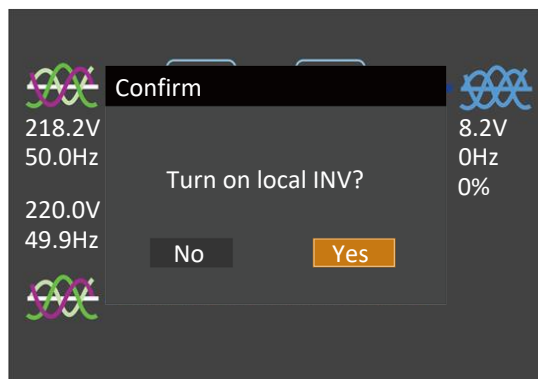

Figure 5-4 Switching the UPS on

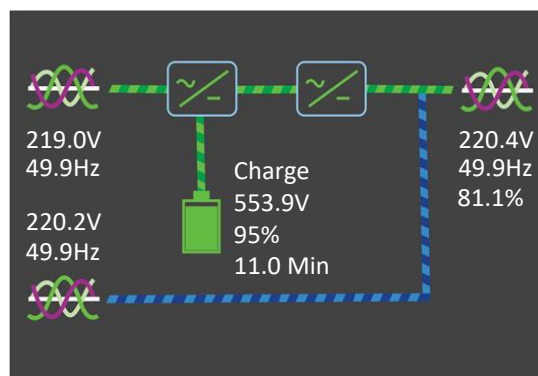

Figure 5-5 Flow page appears after inverter on

7. Access the main menu screen again, select 'Status' to check that the parameters like inverter output voltage and frequency are normal. If so, the start-up is complete.
8. If the battery is not connected, the alarm indicator will be colored yellow. If the battery is connected, the alarm indicator will be off.

5.2.2 Start-up Procedures in Battery Mode (Battery Cold Start)

1. Check and confirm that the batteries are well connected.
2. Open the UPS front door, press and hold any battery cold start button for 2s (see Figure 5-1 for its position). Now, the system is powered on, and the startup screen is displayed. Refer to 4.2.1 Start-up Screen.
25 seconds later, the discharger executes self-test and start-up, and the alarm indicator (red) is solid on. 30 seconds later the discharger start-up phase will complete.
3. Access the flow page, press the power button, and the LCD prompt a dialogue box, as shown in Figure 5-4. After selecting 'YES', the inverter executes self-check and start-up. After the inverter runs normally, the UPS will transfer to normal mode, and the run indicator (green) will be solid on.
4. Access the main menu screen again, select 'Status' to check that the parameters like inverter output voltage and frequency are normal. If so, the start-up is complete.

5.3 Procedures for Transferring Between Operating Modes



The Inverter operating modes include Normal mode and Battery mode.

5.3.1 Transfer from Normal Mode to Battery Mode

Open or disconnect the external power switch Q1 to isolate the mains power and initiate the UPS on battery mode. If you wish to transfer the UPS from Battery mode to Normal mode, wait few seconds for the mains input to recover by closing the external power switch or switch Q1. After about ten seconds, the rectifier automatically restarts, and the inverter restores power.

5.3.2 Transfer from Normal Mode to Bypass Mode



In bypass mode, the load is directly fed by the mains power instead of the pure AC power from the inverter.

In Inverter mode, press the power button. If the bypass is normal, the interface shown in Figure 5-6 is displayed. Select 'YES' to transfer the UPS to Bypass mode, see Figure 5-7 for the power flow page.

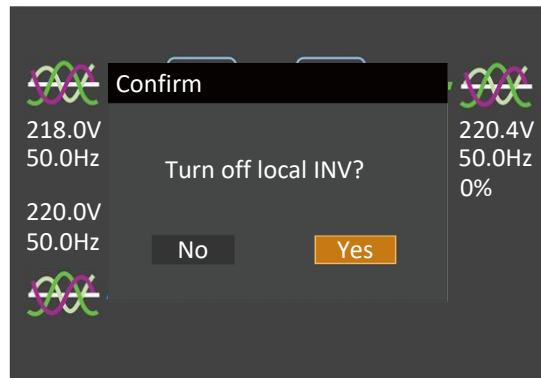

Figure 5-6 Bypass Normal Interface

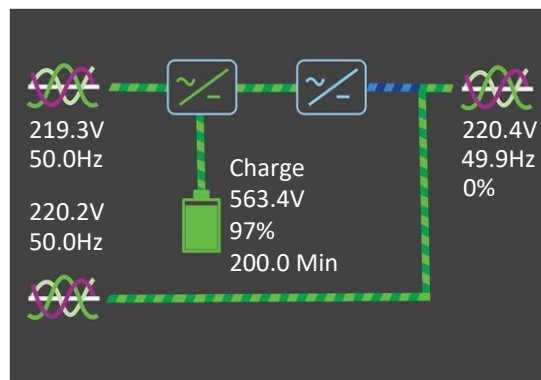

Figure 5-7 Flow Page on Bypass

In Inverter mode, press the power button. If the bypass is abnormal, then the interface shown in Figure 5-8 is displayed, select 'NO' to shut down the UPS output.

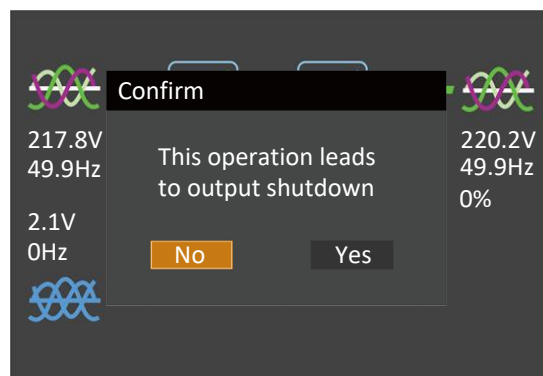

Figure 5-8 Bypass abnormal interface

5.3.3 Transfer from Bypass Mode to Normal Mode

In Bypass mode, press the power button, and the LCD prompts a dialogue box, as shown in Figure 5-9. After selecting 'YES', the inverter executes self-check and start-up. After the inverter runs normally, the UPS will transfer to normal mode, and the run indicator will be solid on.

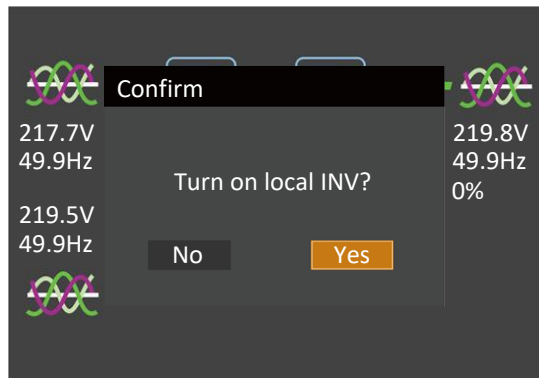

Figure 5-9 Switching the UPS ON

In Bypass mode, press the power button, and the LCD prompts a dialogue box shown in Figure 5-10 if the alarm 'Bypass unable to trace' appears. After selecting 'YES', the system will automatically transfer to Normal mode. Select 'NOT', the system still works in Bypass mode.

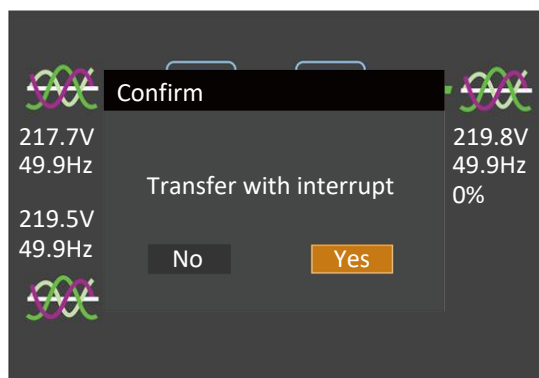

Figure 5-10 Transfer with Interruption

5.3.4 Transfer from Normal Mode to Maintenance Bypass Mode

When the UPS is running in Normal mode, you can use this procedure to transfer the load from inverter output to maintenance bypass.



Power supply interruption danger of the load

Before performing this procedure, check the LCD information first, and ensure that the bypass is normal and synchronized with the inverter. Failure to do so may result in a brief interruption in the power supply to the load.

1. In Inverter mode, press the power button to transfer the load to maintenance bypass mode, and the inverter will shut down.
2. If the UPS runs in single module mode, open the cabinet front door and remove fixing screws of the maintenance bypass switch baffle, rotate the baffle to the left until it is in locked position, then fasten the fixing screws. Now, the LCD displays 'Maint. Switch Closed'.
3. Close the maintenance bypass switch Q3. Now, the maintenance bypass parallels with the UPS bypass.
4. Unplugging the EPO terminal disconnects the output switch Q5, main input switch Q1, bypass input switch Q2 and N line switch QN. At the moment, all the internal power supply is OFF and the LCD no longer displays, and the maintenance bypass powers the load normally.



When the UPS is in maintenance bypass mode, the load is not protected against abnormalities in the mains power supply.



In maintenance mode, the load is directly fed by the mains power instead of the pure AC power from the inverter.

5. If the UPS is equipped with internal batteries, ensure that they have been isolated from the UPS (see Figure 3-2) before carrying out maintenance work on it. If the UPS is equipped with external batteries, just disconnect the external battery switches.



1. *If the maintenance is required, wait 10 minutes for the internal DC bus capacitance discharging.*
2. *The parts of UPS circuits also have hazardous voltage, though the rectifier input switch, bypass input switch and battery switch are disconnected. Therefore, the UPS maintenance is applicable to qualified personnel only.*

5.3.5 Transfer from Maintenance Bypass Mode to Normal Mode

Following UPS maintenance operations, the following procedures may be used to transfer the load from the maintenance bypass to the inverter.

1. If the UPS is equipped with internal batteries, wear arc protective gloves to connect the battery terminals as shown in Figure 3-2. If the UPS is equipped with external batteries, just close the external battery switches.
2. Push the baffle of maintenance bypass switch Q3 to the left to the end position, and let it stay at this position.
3. Close the N line switch QN, output switch Q5, main input switch Q1 and bypass input switch Q2 in turn. Confirm that the LCD is on and the UPS runs in Bypass mode.

4. Following the LCD start-up, ensure that the system is operating in Bypass mode. Set maintenance bypass switch Q3 to off. Return the Q3 baffle to its original position, then fasten the fixing screws.

5. Press the power button on the operator and display panel of the UPS so that the UPS transfers to Inverter mode.



It is important to close the bypass switch before opening the maintenance bypass switch; otherwise the power supply to the load will be interrupted.

5.4 Battery Test Procedures

The battery test function is disabled by default. If you need this function, please contact the customer service engineer of Vertiv.

Battery test type and preconditions







1. There are two battery tests to select from:

- Battery maintenance test: verifies the battery integrity and leads to the battery being partly discharged (20%).
- Battery capacity test: verifies precisely the battery capacity and leads to the battery being fully discharged (until battery low pre-warning alarm)
- 2. The tests can be carried out from the operator control and display panel of the UPS by the operator when the following conditions are satisfied:
 - The load must be between 20% and 80% of rated UPS capacity and must be stable (for battery maintenance test)
 - The load must be between 20% and 80% of rated UPS capacity and must be stable (for battery capacity test)
 - The battery must have been float charging for 5 hours or more before battery capacity test
 - The battery test procedures are password controlled and menu driven. The test is immediately terminated in the event of a battery or a mains failure, and the total load power is supported from the remaining source without interruptions.

Test procedure

1. Access the Maintain page via main menu screen (see Figure 4-10) on the operator control and display panel of the UPS.

Use  or  key to navigate to the Command menu.

2. Use  or  key to select the desired test (the Battery maintenance test or Battery capacity test option), and press  key to confirm it. When prompted, use  or  key to input the password. Press the  key when all digits have been entered.

3. Wait until the test completes.

This test updates the battery information, including the battery back-up time (battery discharge duration during AC input failure) and the battery aging coefficient (battery capacity percentage when compared to a new battery).

4. Stop the test.

If required, the test may be stopped before completion by selecting Stop testing on the Command menu.









The battery capacity self-test needs to guarantee the discharge time not less than 6min, otherwise the battery self-learning time may be insufficient, and the battery curve will not be updated.

5.5 System Test Procedure

The UPS test procedure checks the UPS control functions, LED indicators and audible alarm. This self-test is password controlled and menu driven. It can be carried out from the operator control and display panel by the operator.

Test procedure:

1. Access the Maintain page via main menu screen (see Figure 4-10) on the operator control and display panel of the UPS.

2. Use  or  key to select the System test, and press  key to confirm it. When prompted, use  or  key to input the password. Press the  key when all digits have been entered.

3. Wait until the test completes.

After five seconds, a pop window is displayed to show the result of this diagnosis: rectifier, inverter, monitor OK or fault.

5.6 UPS Shutdown Procedures

5.6.1 Procedures for Completely Powering Down UPS

To shut the UPS down completely and disconnect the power supply to the load, proceed as follows: All power switches, isolating switches and breakers are switched off, and the UPS no longer supplies power to the load.



The following procedures will interrupt the power supply to the load, switching it off.

1. Unplug the EPO terminal to deactivate the rectifier, inverter, bypass, and battery.
2. Set the main input switch Q1, bypass input switch Q2, output switch Q5 and N line switch QN to off. At this point, all the internal power supplies are deactivated, and the LCD screen is switched off.
3. If the UPS is equipped with internal batteries, ensure that they have been isolated from the UPS (see Figure 3-2) before carrying out maintenance work on it. If the UPS is equipped with an external battery, set the corresponding external battery switch to off.



1. Post a label on the AC input distribution line (generally at a distance from the UPS) to alert personnel that UPS maintenance is in progress.
2. Wait 10 minutes for the internal DC bus capacitors to discharge. Then the UPS is completely shut down.



Hazardous voltages are still present on the battery terminals, even after the UPS has been shut down completely.

5.6.2 Procedures for Completely Powering Down UPS While Maintaining Power to Load

The following procedures are applicable to completely powering down the UPS and keeping the power supply to the load. Refer to the procedures in 5.3.4 *Transfer from Normal Mode to Maintenance Bypass Mode*.

5.7 EPO

The REPO is designed to switch off the UPS under emergency conditions (such as fire, flood). To perform EPO, you just need to unplug the EPO terminal, then the system will turn off the rectifier, inverter and stop powering the load immediately (including the inverter and bypass), and the battery stops charging or discharging.



After REPO, if the mains input is present, the UPS control circuit will remain active; however, the output is interrupted.

To completely remove all mains power from the UPS, open the main input switch Q1, bypass input switch Q2, output switch Q5 and N line switch QN in turn, and then open the battery terminals.

5.8 UPS Reset Procedures After EPO

After the UPS has been shut down through EPO or due to inverter overtemperature, overload, battery overvoltage and DC bus voltage, clear the fault according to the alarm message displayed on the LCD screen. Then carry out the following reset procedures to resume normal operation of the UPS.

After confirming the fault has been cleared, just plug the EPO terminal, and the user can perform the following procedures:

1. Access the main menu screen (see Figure 4-10). Use  or  key to select the 'Control' page, see Figure 5-11. Click the 'Clear faults' button, and press  key to make the system exit the REPO/abnormal OFF state, and the alarm indicator in red color is turned off.

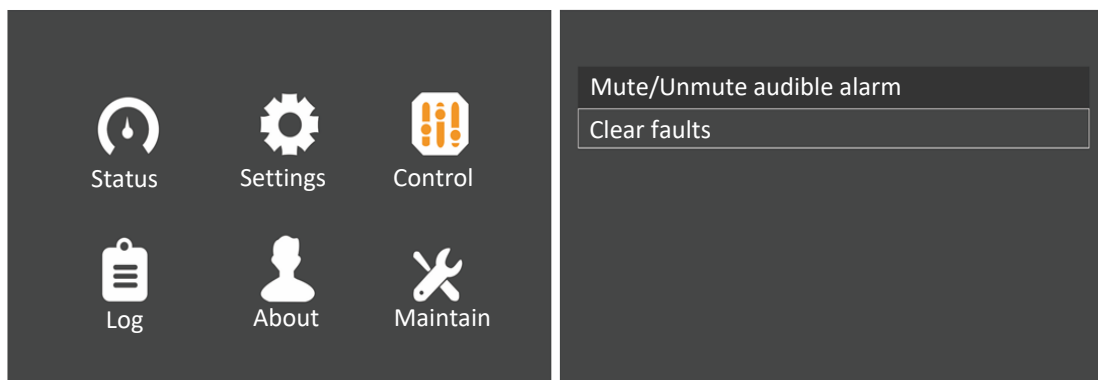

Figure 5-11 Control Page

2. To start the inverter, press the power button. After the inverter runs normally, the UPS will be transferred from Bypass mode to Normal mode, and the run indicator (green) will be solid on. Now the UPS restore is complete.

5.9 Automatic Restart

In the case of a mains failure, the UPS draws power from the battery system to supply the load until the batteries are depleted. When the UPS reaches its EOD threshold, it will shut down.

The UPS will automatically restart and enable output power only when the following conditions are met:

1. If the UPS Auto Restart function is enabled.
2. After the Auto Restart delay has expired (default: 10s). During the Auto Restart delay, the UPS will charge the battery to provide a safety margin for equipment shutdown if input power fails again.
3. If the Auto Restart function is disabled, you can restart the UPS manually by pressing the power button.



During the automatic restart process, manual startup is disabled. Automatic restart must be set by Vertiv engineer through Vertiv setting software.

5.10 Selecting Language

The LCD menus are available in 13 languages.

Procedures for selecting the language:

1. Access the main menu screen and press the  or  key to switch the cursor to select 'Settings', then press the  key to confirm it. See Figure 5-12.

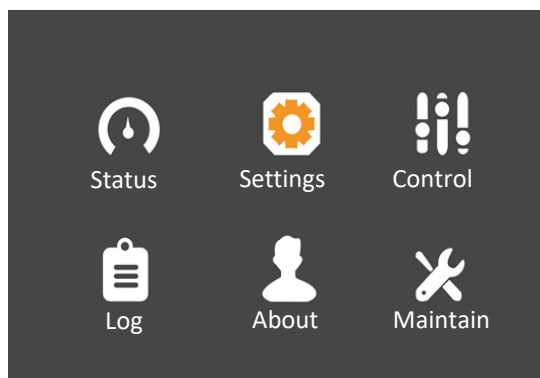

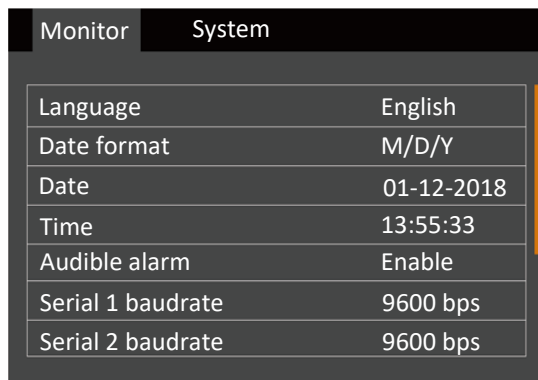

Figure 5-12 Main Menu

2. Press the  key to move the cursor to 'Monitor', see Figure 5-13.



Monitor	System
Language	English
Date format	M/D/Y
Date	01-12-2018
Time	13:55:33
Audible alarm	Enable
Serial 1 baudrate	9600 bps
Serial 2 baudrate	9600 bps

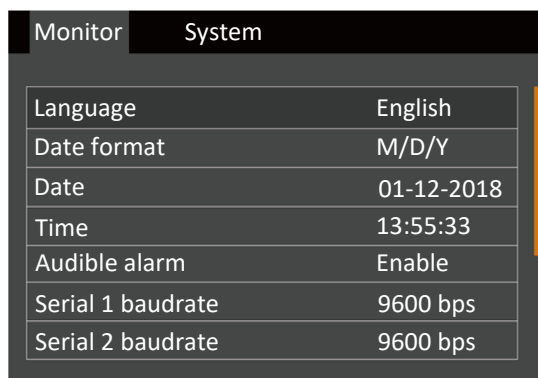

Figure 5-13 Monitor Interface

3. Press the  key to highlight the language, see Figure 5-14.



Monitor	System
Language	English
Date format	M/D/Y
Date	01-12-2018
Time	13:55:33
Audible alarm	Enable
Serial 1 baudrate	9600 bps
Serial 2 baudrate	9600 bps

Figure 5-14 Language Selection

4. Press the  or  key to select your required language, then press the  key to confirm it. At this point, the LCD information will be the displayed in your selected language. See Figure 5-15.

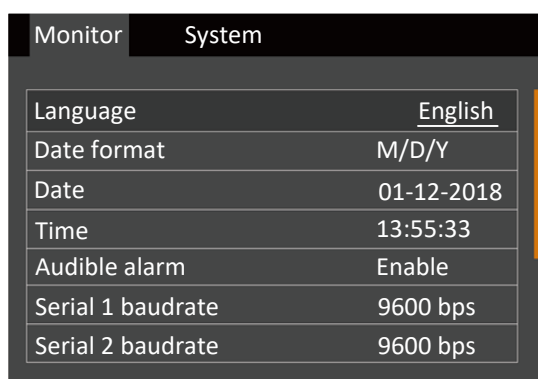

Monitor	System
Language	<u>English</u>
Date format	M/D/Y
Date	01-12-2018
Time	13:55:33
Audible alarm	Enable
Serial 1 baudrate	9600 bps
Serial 2 baudrate	9600 bps

Figure 5-15 Changing Language

5. Press the  key several times to back to the main menu screen.

5.11 Changing Current Date and Time

Procedures for changing the system date and time:

1. Access the main menu screen and press the or key to switch the cursor to select 'Settings', then press the key to confirm it. See Figure 5-16.

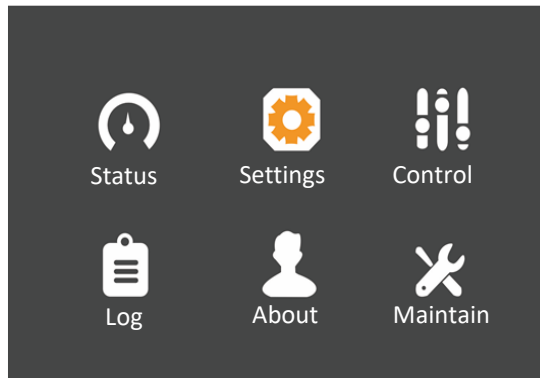

Figure 5-16 Main Menu Screen

2. Press the key to move the cursor to 'Monitor', see Figure 5-17.

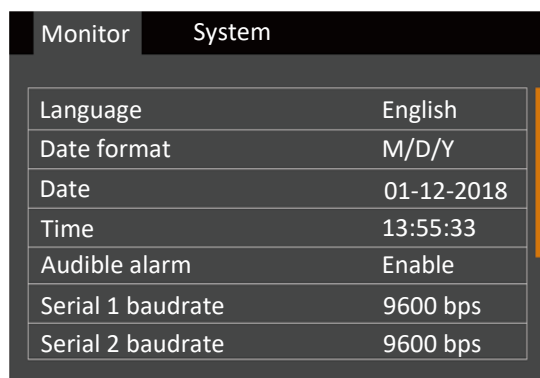

Figure 5-17 Monitor Interface

3. Press the key and press the or key to highlight the date and time, see Figure 5-18.

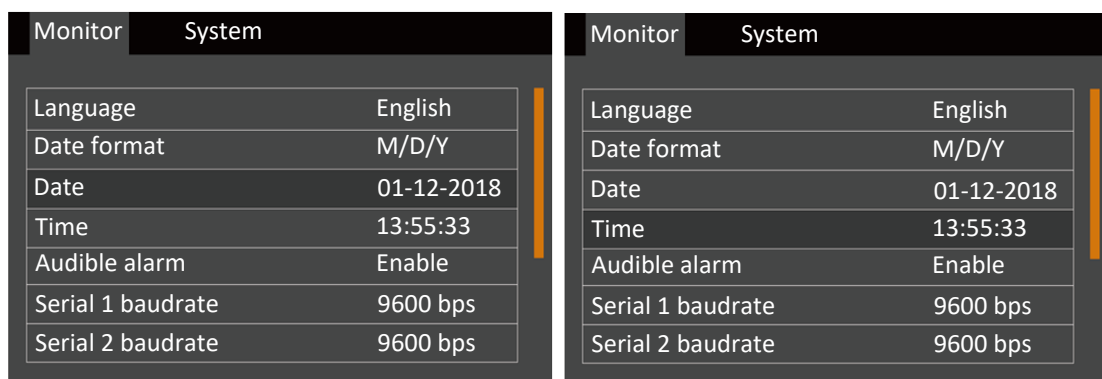

Figure 5-18 Selection of Date and Time

4. Press the **Enter** key, move the cursor and press the **▲** or **▼** key to change the date and time as required. See Figure 5-19.

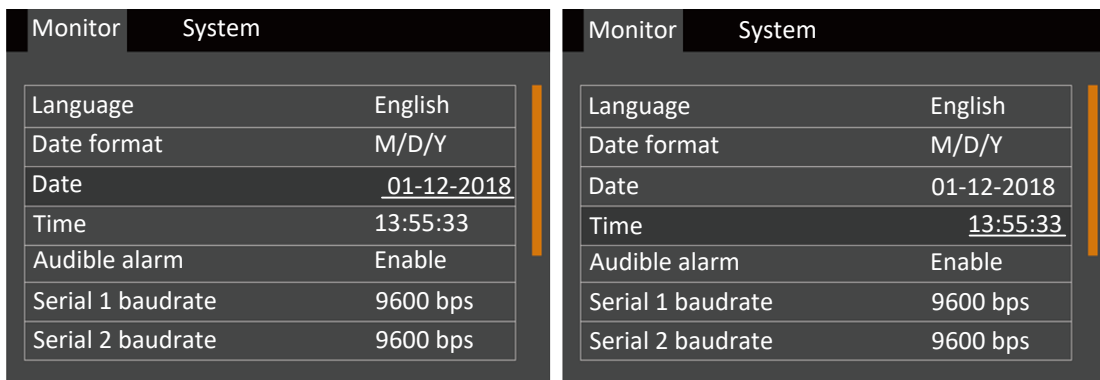

Figure 5-19 Changing Date and Time

5. Press the **Enter** key to confirm it, and then press the **Esc** key several times to back to the main menu screen.

5.12 Setting Password

1. After switching the UPS on, access the main menu screen and press the **▲** or **▼** key to move the cursor to select 'Settings'. See Figure 5-20.

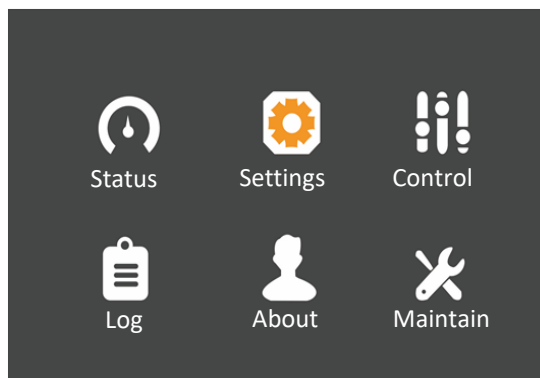

Figure 5-20 Main Menu

2. Press the key, the interface shown in Figure 5-21 is displayed.

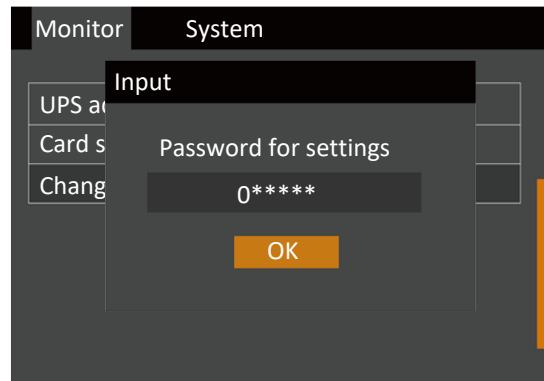

Figure 5-21 Inputting Password

To change the password, proceed as follows:

1. Press the key to move the cursor to the 'Monitor' interface, see Figure 5-22.

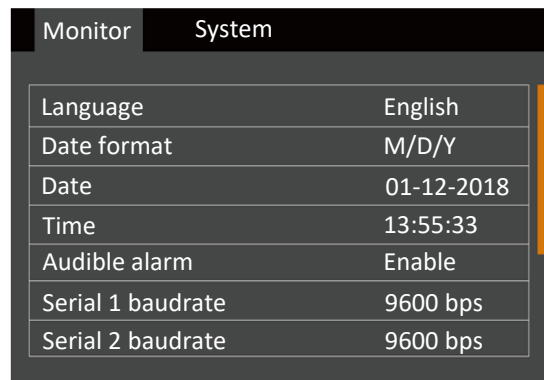

Figure 5-22 Monitor Interface

2. Press the key, then press the key to select 'Change settings password', see Figure 5-23.

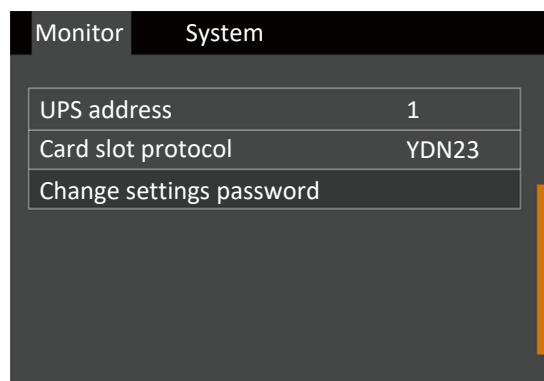

Figure 5-23 Changing Settings Password

3. Press the key, the interface shown in Figure 5-24 is displayed.

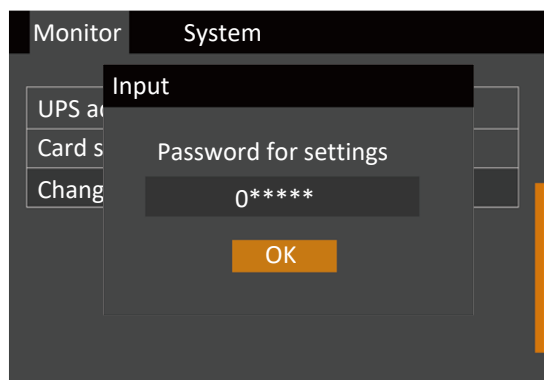

Figure 5-24 Password for Settings

4. Enter the current password and press the key to confirm; at this point the system requests the user to enter a new password. See Figure 5-25.

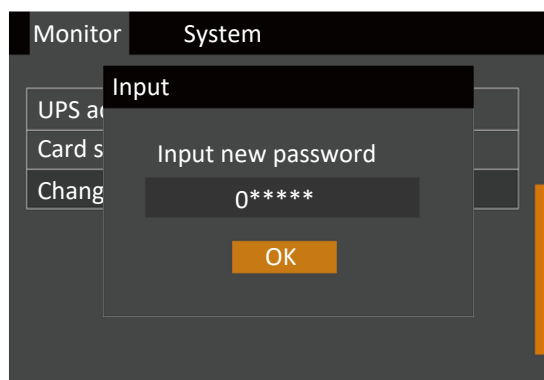

Figure 5-25 Inputting New Password

5. After entering the new password, press the key to confirm it; at this point the system requests the user to confirm the new password by entering it again, see Figure 5-26.

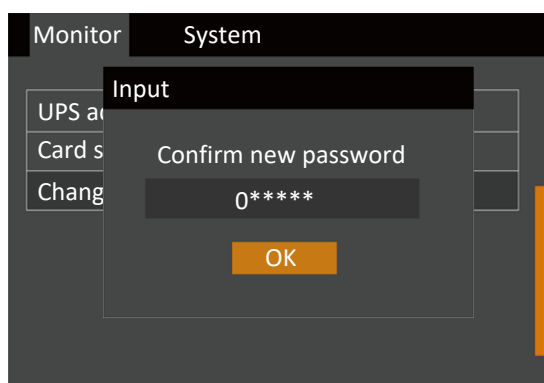



Figure 5-26 Confirming New Password

6. After confirming the new password, press the  key; at this point system prompt a dialog box indicating that the password has been changed successfully, see Figure 5-27.

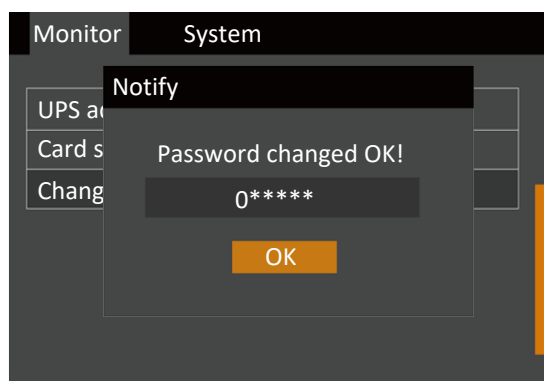



Figure 5-27 Password Changed Successfully

7. Press the  key several times to go back to the main menu screen.



In order to access the UPS parameters, it is necessary to enter the correct password (default: 111111)

6 Parallel System and LBS System

This chapter gives details on the installation of parallel system and LBS system.

6.1 General

The UPS parallel system consists of up to four single UPS of the same model. The parallel system does not require a centralized bypass. Instead, each UPS bypass shares the load when the system is transferred to the mains bypass supply.

From a 'power' viewpoint, each module is internally identical to the 'single module' configuration. A parallel system requires inter-module control signals to manage the load sharing, synchronizing and bypass switching. The control signals are connected through the parallel cables, which are multi-way ribbon cables connected between the units of the system to form a ring.

When two or more modules are to be connected in parallel, it is recommended that inductor should be inserted in the bypass line. This can be installed internal to the UPS as an option.

6.2 Requirements

A UPS system comprising of multiple parallel-connected UPSs is equivalent to a large UPS system. Nevertheless, it provides increased system reliability. To ensure equal utilization of all UPSs and compliance with relevant wiring regulations, the following requirements must be met:

1. All single UPSs must have the same capacity.
2. The bypass input power and the rectifier input power must be connected to the same neutral line input terminal.
3. If a Residual Current Detector (RCD) is required, it must be set correctly and installed before the same neutral line input terminal, or it must monitor the protective earth current of the system. Refer to '*Warning: high leakage current*' of *Safety Precautions before Contents*.
4. The outputs of all single UPSs must be connected to the same output bus.

6.3 System Installation Procedures

The basic installation procedure of a parallel system comprising two or more UPS modules is the same as that of single module system. This section only introduces the installation procedures specific to the parallel system. The installation of a parallel UPS should follow the installation procedure for a single UPS module with the additional requirements detailed in this section.



To achieve normal operation of the parallel system, Vertiv service personnel must execute the CAN resistance operation. Failure to do so could result in system fault.

6.3.1 Preliminary Checks

Ensure that correct parallel cable option has been selected, and that the module ratings, model, and software and hardware releases are consistent.



To achieve coordinated operation of the modules in the parallel system, it is required to configure each module separately using Vertiv setting software. This must be done by Vertiv service personnel.

6.3.2 Cabinet Installation

Place the UPS modules side by side and interconnect as shown in Figure 6-1. The output distribution mode (QE1, QE2 must be configured) shown in Figure 6-1 is recommended to facilitate maintenance and system testing.

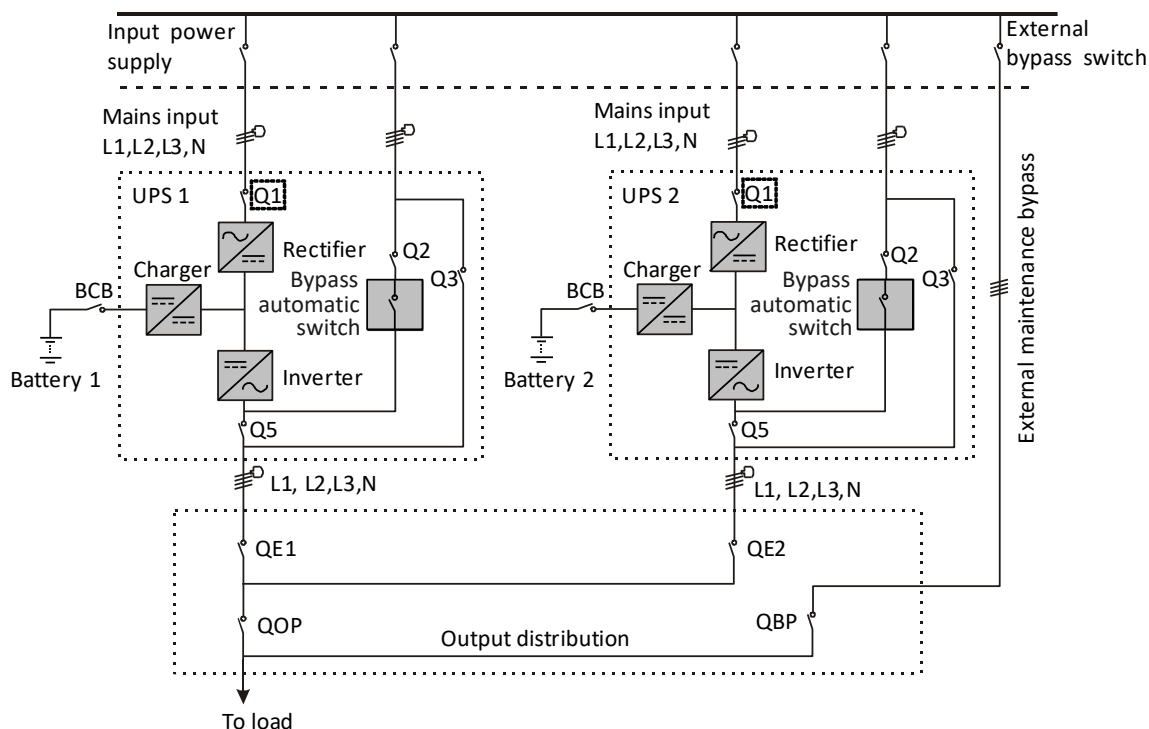

Figure 6-1 Schematic of typical parallel system (with common input, separate batteries and output)

6.3.3 Power Cables

The power cable wiring is similar to that of the UPS module. Refer to 3.1 *Wiring of Power Cable*.

The bypass and rectifier input supplies must use the same neutral line input terminal. If the input has a current leakage protective device, the current leakage protective device must be fitted upstream of the neutral line input terminal.



1. The power cables of each UPS module (including the bypass input cables and UPS output cables) should be of the same length and specifications to facilitate load sharing.
2. The UPS adopts common input configuration and split bypass configuration. If the mains input and bypass input come from two different transformers, then these two transformers should share one grounding grid.

6.3.4 Parallel Cables

Shielded and double-insulated parallel cables available in lengths of 5m, 10m and 15m must be interconnected between the UPS modules in a ring configuration, as shown in Figure 6-2.

Method: connect a single module parallel cable from its PARALLEL1 port to the PARALLEL2 port of another module. Repeat this step for all the other parallel cables.

The ring connection ensures the reliability of the control of the parallel system. Make sure that the cables are securely connected before starting the system!

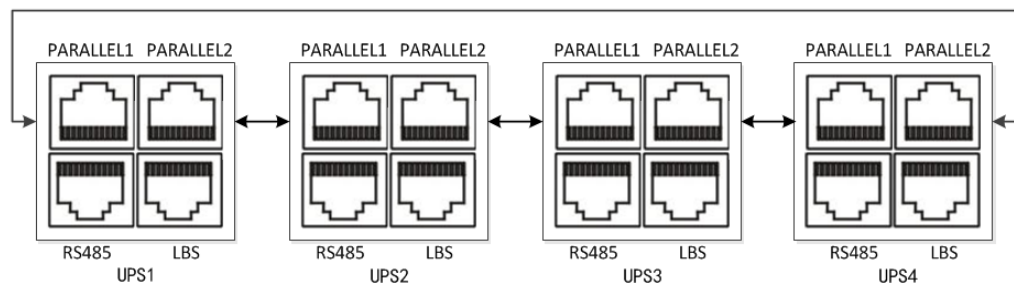

Figure 6-2 Parallel Cables Connection

6.3.5 Remote EPO

In addition to the EPO terminal provided by each UPS module to control the EPO of each module respectively, the parallel system also provides remote EPO function for controlling all UPS modules to shut down simultaneously from a remote terminal, as shown in Figure 6-3.



1. The remote EPO switch must provide dry contact signal, which is normally open or normally closed.
2. The external EPO device can be composed of another control system which can disconnect UPS mains supply or bypass input.

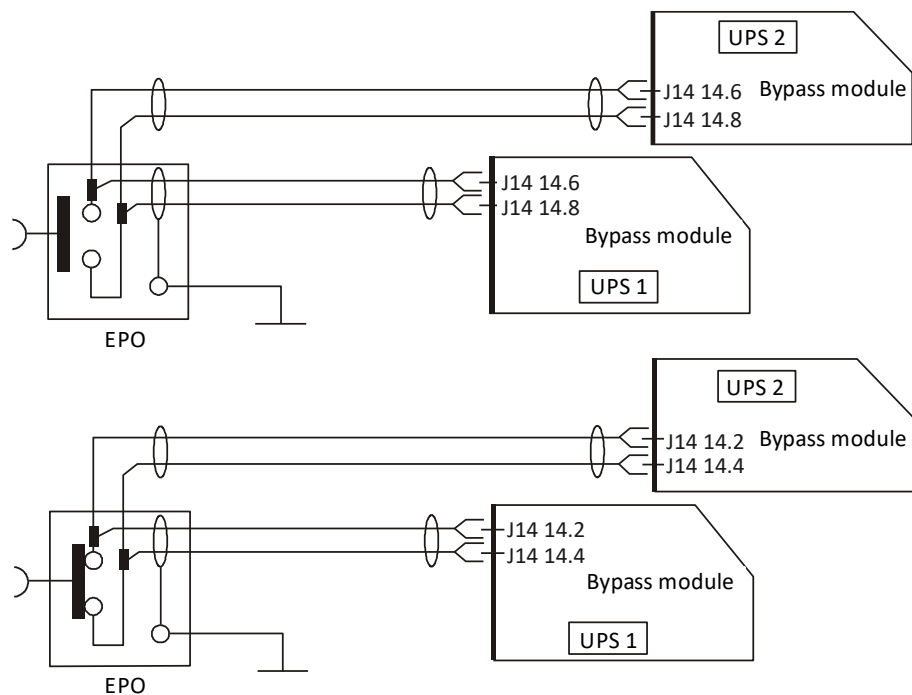

Figure 6-3 EPO Circuit Diagram



In Figure 6-3, the upper one is Normally Open type, and the lower one is Normally Closed type.

6.4 Operation Procedures for Parallel System

6.4.1 Check Before Start-up

1. Check and confirm that the UPS power distribution mode is correct, that the power cables and signal cables are correctly connected, and there are no short circuits.
2. Check that the batteries are properly installed, the cables are correctly connected, and that the positive and negative battery poles are correct.
3. Check all the operating status of the parallel system, ensure that the phase sequence of the main, bypass and output of each UPS is correct and consistent, that the connection of the parallel cable is reliable, and that the user load is not connected during power-on.
4. Measure the mains voltage and frequency and verify that they are correct.

5. When the UPS is switched on, the UPS output terminals are energized. If the load has already been connected to the output terminals, make sure that it is safe to apply power to it.



1. *These procedures result in mains voltage being applied to the UPS output terminals.*
2. *If any load equipment is connected to the UPS output terminals, check with the user that it is safe to apply power. If the load is not ready to receive power, disconnect the downstream load switch, and paste a warning label on the connection point of the load.*

6.4.2 Parallel System Parameters Setting



The parameters of parallel system must be set by Vertiv engineer through Vertiv setting software.

6.4.3 Power-on Procedures for Parallel System

1. Set the parallel parameter of each UPS in the parallel system, then commission the inverter.

The specific commissioning procedures are as follows:

- a) Ensure that the total external maintenance bypass switches are open in the parallel system. Open the front door of each UPS, ensure that the internal maintenance bypass switch Q3 is off, and that the input cables and PE terminals are securely connected.



To avoid misreporting as faults, all operations relating to disconnection or connection of the maintenance bypass switch shall be finished within three seconds.

b) Close the total bypass input switch Q2.

c) Close the N line switch QN, output switch Q5, bypass input switch Q2, main input switch Q1 and all the external output isolating switches (if any) in turn. Now, the system is powered on, and LCD screen is activated. See 4.2.1 Start-up Screen.

d) The UPS internal cooling fan starts, and the rectifier executes self-check and starts to run (see Figure 5-2 for power flow page). The rectifier runs in normal state for about 30 seconds, after which the rectifier start-up phase is complete. Please confirm that the LCD displays bypass and main input normally, and that the current log window generates an alarm of 'PowerCAN Comms. Abnormal' or 'Discrete Bus Comms. Abnormal', otherwise you should check that the switch Q2 and switch Q1 have been closed, and that parallel cables of each UPS have been well connected. The alarm indicators (red) are always off till all the UPSs in parallel system are rectified.

e) Refer to 6.4.2 Parallel System Parameters Setting for the parallel parameters setting for each UPS. Carry out the following procedures if the UPS is running normally.

f) Press the power button of one UPS and press the Enter key to start the UPS. The run (green) indicator blinks, and the inverter will start, then the run indicator will be on. If the battery is not connected, the alarm indicator will be solid on, and the buzzer will beep every second. If the battery is connected, the alarm indicator will turn off.

g) If the UPS is working normally, press the power button of this UPS for two seconds to turn off the inverter.

h) Repeat steps a to g to power on and commission the inverter of other UPSs respectively.



Carry out the parallel commissioning after each UPS is working normally.

2. After confirming that the inverter of each UPS is normal, commission the parallel system, the specific procedures are as follows:

a) Close the external and internal I/O switch of each UPS, and all UPSs are powered on at the same time. After the start of the rectifier is finished, press the power button of one UPS to start the inverter, and then the run indicator (green) will be on. b) Start the inverter of the second UPS, check whether there is an alarm on the LCD, and confirm that the UPS parallel works normally.

c) Follow the methods to start inverter of the third or the fourth UPS to connect the UPS into the parallel system.



1. During the parallel power-on, confirm that the external output MCB of each UPS has been closed, and that all the inverter output of the UPSs is connected parallelly.

2. During the parallel power-on, confirm that the system is working normally, and then feed power to the load, to void load power failure.

6.4.4 Maintenance Bypass Procedures



If the UPS system consists of more than 2 parallel UPS modules, and the load capacity exceeds that of the single module capacity, do not use the internal maintenance bypass switch.

This operation will make the load transfer from UPS power supply protection state to direct connection with AC input bypass state.



Power supply interruption danger of the load

Before performing this procedure, you should check the LCD information first, and ensure that the bypass is normal, and inverter synchronized. Otherwise, it may result in the load power interruption for a while.

1. Press the power button of each UPS to shut down the inverter, till all the UPSs in parallel system transfer to Bypass mode.
2. Close the UPS external total maintenance bypass switches, and do not close the internal maintenance bypass switch Q3 of each UPS.
3. At this moment, the external total maintenance bypass should be parallely connected with each UPS's bypass.
4. At this moment, the LCD of each UPS displays ' Maint. Switch Closed'.



When the UPS is in maintenance mode, the load does not have the mains abnormal protection.

5. Press the remote EPO button of each UPS for 2sec (if any) or unplug the EPO terminal of each UPS to stop the operation of rectifier, inverter, bypass, and battery, but this action will not affect the maintenance bypass power the load normally.



In maintenance mode, the load is directly fed by the mains power instead of the pure AC power from the inverter.

6. Disconnect the main input switch Q1, bypass input switch Q2, output switch Q5 and N line switch QN of each UPS in turn.

At present, all the internal power supply is off, and the LCD no longer displays.

7. If the UPS is equipped with internal batteries, ensure that they have been isolated from the UPS (see Figure 3-2) before carrying out maintenance work on it. If the UPS is equipped with an external battery, set the corresponding external battery switch to off.



1. *If the maintenance is required, wait 10 minutes for the internal DC bus capacitance discharging.*
2. *The parts of UPS circuits also have hazardous voltage, though the rectifier input switch, bypass input switch and battery switch are disconnected. Therefore, the UPS maintenance is applicable to qualified personnel only.*

6.4.5 Procedures for Isolating One UPS Module from Parallel System



These procedures shall only be carried out by service personnel of Vertiv or under their guidance.



Before operation, confirm that the system capacity has redundancy to avoid system shutdown due to overload.

The following procedures apply when one UPS module must be isolated from the parallel system for repair due to serious fault:

1. Unplugging the EPO terminal stops the operation of rectifier, inverter, bypass, and battery, but this action will not affect other UPSs in parallel system to normally power the load.
2. Disconnect the main input switch Q1, bypass input switch Q2, output switch Q5 and N line switch QN of the UPS. At present, all the internal power supply is off, and the LCD no longer displays.
3. If the UPS is equipped with internal batteries, make ensure that they have been isolated from the UPS (see Figure 3-2) before carrying out maintenance work on it. If the UPS is equipped with an external battery, set the corresponding external battery switch to off.

6.4.6 Procedures for Inserting One Isolated UPS Module in Parallel System



These procedures shall only be carried out by service personnel of Vertiv or under their guidance.

The following procedures are used to reintegrate a UPS module that has been previously isolated from the parallel system:

1. If the UPS is equipped with internal batteries, ensure that the external battery terminals (see Figure 3-2) are well connected.

Close the N line switch QN, output switch Q5, bypass input switch Q2 and main input switch Q1 in turn. At present, the system is powered on, and LCD screen is activated. See 4.2.1 Start-up Screen.

2. The UPS internal cooling fan starts, and the rectifier executes self-check and starts to run (see Figure 5-2 for power flow page). The rectifier runs in normal state for about 30 seconds, after which the rectifier start-up phase is complete. Please confirm that the LCD displays bypass and main input normally, and that the current log window generates an alarm of 'PowerCAN Comms. Abnormal' or 'Discrete Bus Comms. Abnormal', otherwise you should

check that the switch Q2 and switch Q1 have been closed, and that parallel cables of each UPS have been well connected.

3. Refer to 6.4.2 *Parallel System Parameters Setting for the parallel parameters setting* for each UPS. Carry out the following procedures if the UPS is running normally.

4. Press the power button of one UPS and press the Enter key to start the UPS. Then the run indicator will be on.

5. After this UPS runs in Inverter mode, close the external output switch (if any), and connect this UPS to the parallel system.

6.4.7 Procedures for Completely Powering Down UPS

Complete UPS shutdown and load power-off should follow this procedure. All power switches, isolating switches and breakers are disconnected, and then UPS no longer supplies power to the load.



The following procedures will cut off the load power, making the load completely power off.

1. Press the remote EPO button of each UPS for 2secs (if any) or unplug the EPO terminal of each UPS to stop the operation of all the rectifiers, inverters, bypasses, and batteries.

2. If the UPS is equipped with internal batteries, ensure that they have been isolated from the UPS (see Figure 3-2) before carrying out maintenance work on it. If the UPS is equipped with an external battery, set the corresponding external battery switch to off.

3. Disconnect the main input switch Q1, bypass input switch Q2, output switch Q5 and N line switch QN of each UPS. At present, all the internal power supply is closed and the LCD no longer displays.



Hazardous battery voltage

The battery terminals still have hazardous voltage after the UPS complete shutdown.

6.4.8 Procedures for Complete UPS Shutdown While Maintaining Power to Load

The following procedures are applicable for completely powering down the UPS and still keeping the power supply to the load. Refer to the procedures in 6.4.4 *Maintenance Bypass Procedures*.

6.5 LBS System

6.5.1 Overview

An LBS system consists of two independent UPS systems, each containing one or more parallel UPS modules. The LBS system is highly reliable and is applicable to the load with multiple inputs. For single-input load, an STS can be installed to feed power to the load.

6.5.2 Cabinet Installation

The system uses the LBS cables to synchronize the output of the two independent (or parallel) UPS systems. One system is designated as the master, the other is designated as the slave. The operation modes of the parallel system comprise master and/or slave operation in normal or bypass mode. Refer to *Figure 6-4* and *Figure 6-5* for details.

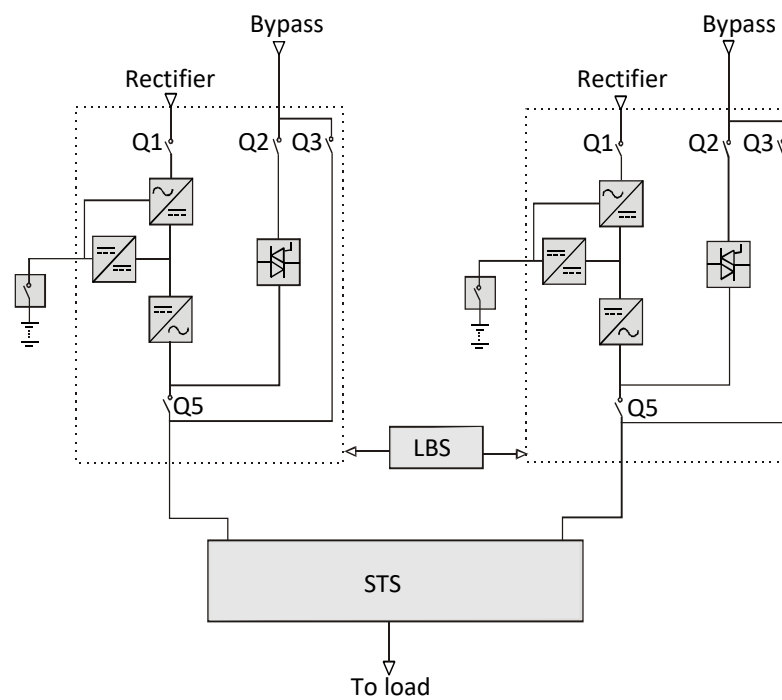

Figure 6-4 LBS System (UPS module)

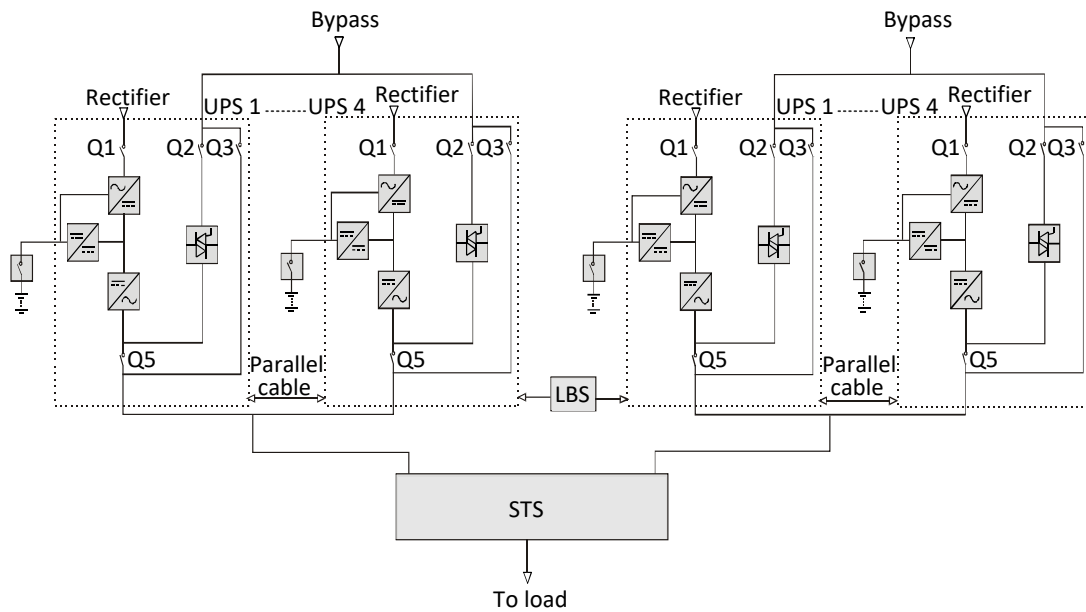

Figure 6-5 LBS System (parallel system)



In a dual-bus system, the two UPS systems must have the same power rating, voltage and frequency, and the load should not exceed the power rating of a UPS module system.

6.5.3 Connecting Power Cables

The power cable of dual-bus system is identical to that of single system. Refer to 3.1 Wiring of Power Cable.

The bypass and rectifier input supplies must use the same neutral line input terminal. If the input has a current leakage protective device, the current leakage protective device must be fitted upstream of the neutral line input terminal.

6.5.4 Connecting LBS Cables

Connect the shielded and double-insulated LBS optional cables (5m, 10m, and 15m) between the LBS port of the two UPS systems as shown in Figure 6-6 and Figure 6-7.

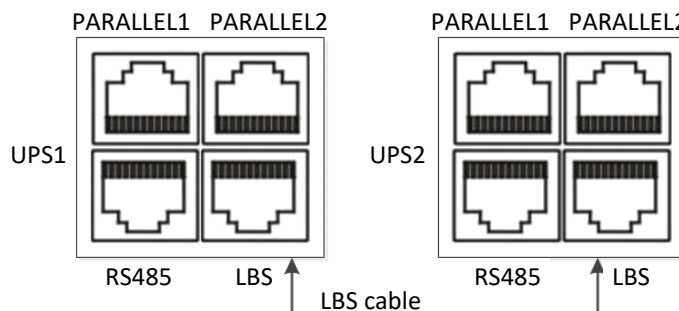

Figure 6-6 Connection of typical LBS system (UPS module)

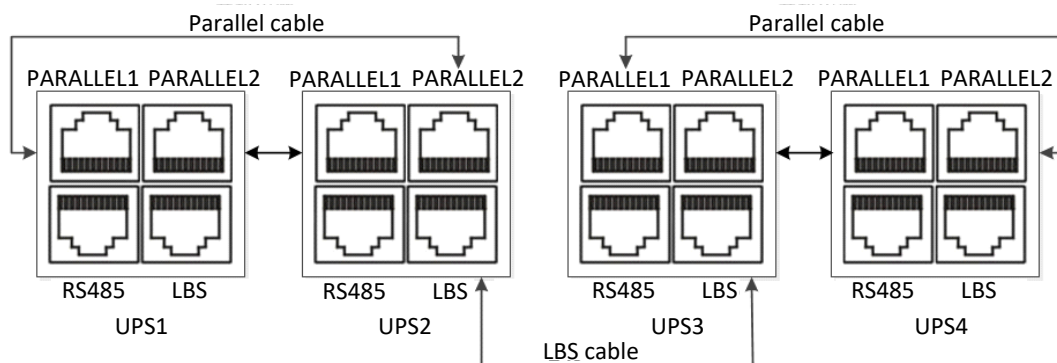

Figure 6-7 Connection of typical LBS system (parallel system)

6.5.5 LBS Parameters Setting



The parameters of LBS parameters must be set by Vertiv engineer through Vertiv setting software

6.5.6 LBS System Commissioning

Refer to 6.4 Operation Procedures For Parallel System for details.

7 Communication

This chapter briefly introduces the UPS communication.

The communication ports include: intelligent card port, dry contact port, monitoring port, RS485 port, CAN port, built-in port, LBS port, parallel port, intelligent temperature sensor port and battery monitor port.

7.1 Installing Intelligent Card

7.1.1 Intelligent Card Port

The UPS provides two Intellislot ports (see Figure 7-1, taking 20kVA model for example) to install the intelligent cards on site. Open the front door of the UPS, you can see the protective cover located on the cabinet left side. Remove the protective cover to install communication device options, including SIC card, IS-UNITY-DP card, IS-UNITY-LIFE card, and IS-RELAY card.

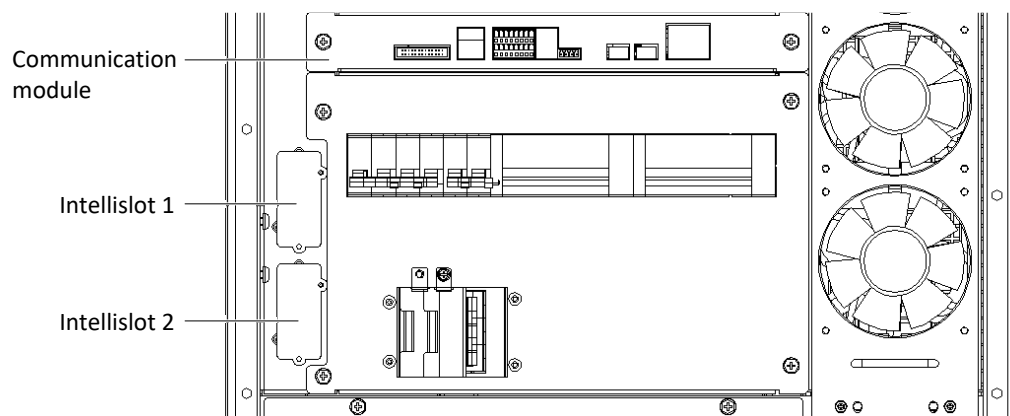

Figure 7-1 Intelligent card installation

7.1.2 Intelligent Card Option

SIC card

SIC card (see Figure 7-2) is a network management card, that makes the intelligent devices (such as UPS, air conditioner, static transfer system (STS), sever power management system (SPM), and so on) produced by Emerson have network communication capability. The SIC card can also be used with the Network Shutdown designed by Emerson to provide safe automatic shutdown function for the computer, in which the Network Shutdown is installed, to protect data and reduce loss. For more information of the SIC card, refer to *Site Interface Web/SNMP Agent Card User Manual*.

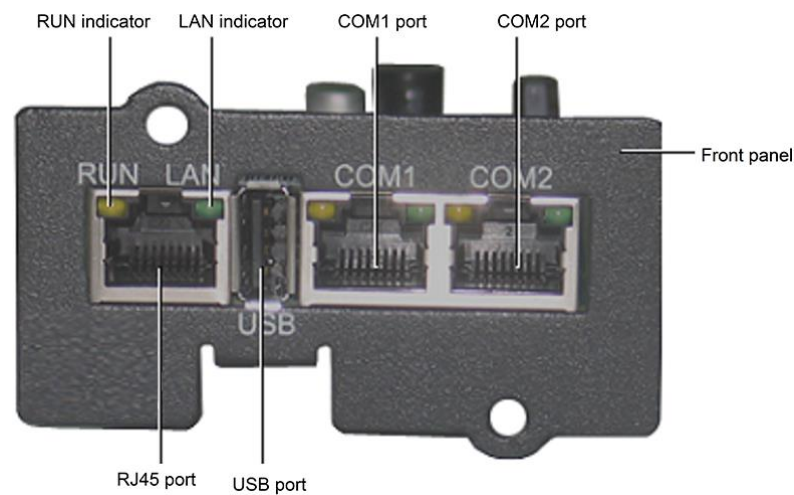

Figure 7-2 SIC Card

IS-UNITY-DP card

See Figure 7-2 for the appearance of IN-UNITY-DP card.



Figure 7-3 IS-UNITY-DP Card

For further description of the IS-UNITY-DP card, refer to *Liebert IntelliSlot™ Unity Card User Manual-Web, SNMP, Modbus, BACnet, YDN23*.

IS-UNITY-LIFE card

See Figure 7-3 for the appearance of IN-UNITY-LIFE card.



Figure 7-4 IS-UNITY-DP Card

For further description of the IS-UNITY-LIFE card, refer to *Liebert IntelliSlot™ Unity Card User Manual-Web, SNMP, Modbus, BACnet, YDN23*.

IS-RELAY card

The appearance of the IS-Relay card is shown in Figure 7-5.



Figure 7-5 IS-RELAY Card

For more information of the IS-Relay card, refer to *the Liebert IntelliSlot IS-Relay Card User Manual*.

7.1.3 Installation Procedures



Some electron components in the intelligent card are sensitive to static, therefore, do not touch the electron components or circuit in the intelligent card by hand or other conductive materials, so as to protect the intelligent card against static shock. When removing or installing the intelligent card, hold the card side edge to operate it.

1. Remove the protective cover on the UPS intelligent card, retain the screws, and keep the protective cover for future use.
2. Insert the intelligent card (along two sides of the Intellislot port) into the recommended port position in Figure 7-1, and fasten the screws.

Note:

1. SIC card, UNITY-DP card, UNITY-LIFE card and IS-RELAY card can be installed at Intellislot1 or Intellislot2.
2. When installing the UNITY-DP card or the UNITY-LIFE card at Intellislot1 or Intellislot2, if you wish to change the baud rate, change the 'serial port 2 baudrate' on the operator and display panel.

3. When installing the SIC card at Intellislot2, if you wish to change baud rate, just change the 'serial port 2 baudrate' on the operator and display panel.
4. When installing the SIC card at Intellislot1, if you wish to change the baud rate, you first need to confirm the current communication mode of SIC card is RS232 or RS485 via the SIC card web interface. If RS232 communication mode, it can be realized by changing 'serial port 1 baudrate' on the operator and display panel; if RS485, it can be realized by changing 'serial port 2 baudrate' on the operator and display panel.
5. The path of 'serial port 1 baudrate' and 'serial port 2 baudrate' on the operator and display panel is: main menu screen -> setting -> monitor -> serial port 1 baudrate or serial port 2 baudrate.
6. The path of main menu screen -> setting -> monitor -> UPS address is used to set the communication address of this UPS through the YDN23 protocol.
7. The path of main menu screen -> setting -> monitor -> card slot protocol is used to set the RS485 bus protocol in the two intelligent card ports, and the protocol used is YDN23 or Velocity. The SIC card adopts YDN23 protocol while UNITY-DP card and UNITY-LIFE card adopt Velocity protocol.



These procedures shall only be carried out by service personnel of Vertiv or under their guidance.

7.2 Connection Cables for Dry Contact Port

For on-site specific needs, the UPS needs an auxiliary connection to realize battery system (including the external battery switch) management, communicate with PC, provide alarm signal to external devices, realize remote EPO or provide bypass back-feed circuit breaker signal and parallel communication. These functions are realized through the communication box in the UPS cabinet. As shown in Figure 7-6, the communication box provides the following ports, and the port description is shown in Table 7-1.

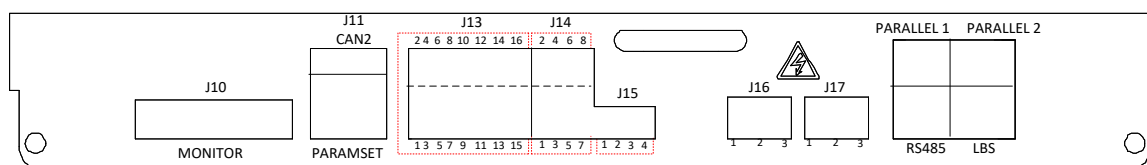

Figure 7-6 Pin layout of dry contact ports

Table 7-1 Description of the dry contact ports

Silkprint	Port name	Pin No.	Pin name	Meaning	Remarks
J11	Communication port	CAN2	CAN communication port	Default	
	Host port	PARAMSET	Paramset port	Communicate with PC, configure the parameters for the UPS via this port	
J13 ¹	Input dry contact	1	EXT_MIB	On Generator / Transfer to Inverter Inhibited / External MIB (default) / External MBB / Module Output Breaker / Battery Ground Fault / Charger Shutdown / ECO Inhibited (Inverter Mode Preferred) / Start Battery Maintenance Self-check / Stop Battery Maintenance Self-check / Alarm Cleared. Pin1 and Pin3 shorted to enable this function	Can configure input dry contact J13-1
		3	GND_SELV		
		5	MOB	On Generator / Transfer to Inverter Inhibited / External MIB / External MBB / Module Output Breaker (default) / Battery Ground Fault / Charger Shutdown / ECO Inhibited (Inverter Mode Preferred) / Start Battery Maintenance Self-check / Stop Battery Maintenance Self-check / Alarm Cleared. Pin5 and Pin7 shorted to enable this function	Configurable input dry contact J13-5
		7	GND_SELV		

Silkprint	Port name	Pin No.	Pin name	Meaning	Remarks
J13 ¹	Input dry contact	9	EXT_MBB	On Generator / Transfer to Inverter Inhibited / External MIB / External MBB (default) / Module Output Breaker / Battery Ground Fault / Charger Shutdown / ECO Inhibited (Inverter Mode Preferred) / Start Battery Maintenance Self-check / Stop Battery Maintenance Self-check / Alarm Cleared.	Configurable input dry contact J13-9
		11	GND_SELV	Pin9 and Pin11 shorted to enable this function	
		13	GEN_MODE	On Generator (default) / Transfer to Inverter Inhibited / External MIB / External MBB / Module Output Breaker / Battery Ground Fault / Charger Shutdown / ECO Inhibited (Inverter Mode Preferred) / Start Battery Maintenance Self-check / Stop Battery Maintenance Self-check / Alarm Cleared.	Configurable input dry contact J13-13
		15	GND_SELV	Pin13 and Pin15 shorted to enable this function	
		2	Inhibit_trans_to_inverter	On Generator / Transfer to Inverter Inhibited (default) / External MIB / External MBB / Module Output Breaker / Battery Ground Fault / Charger Shutdown / ECO Inhibited (Inverter Mode Preferred) / Start Battery Maintenance Self-check / Stop Battery Maintenance Self-check / Alarm Cleared.	Configurable input dry contact J13-2
		4	GND_SELV	Pin2 and Pin4 shorted to enable this function	
		6, 8, 10	Default		
		12	TEM_DETECT_CONTROL	Built-in battery temperature detection control	
		14	TEMP_PULSE_IN	Built-in battery temperature detection input	
		16	GND_SELV	GND	

Silkprint	Port name	Pin No.	Pin name	Meaning	Remarks
J14 ²	Output dry contact and REPO port	1	On_Battery_A	System Alarm /On Battery (default) /Battery Low Capacity /UPS Fault / On Bypass / UPS /Remote EPO / Main input abnormal / On Maintenance Bypass / Load Shed Signal 1 / Load Shed Signal 2 / Internal MBB Closed.	Configurable input dry contact J14-1/3
		3	On_Battery_B	Pin1 and Pin3 shorted for alarm state. Note: We recommend adopting the switch with normally-closed auxiliary contact when load shed signal is selected	
		5	Summary_Alarm_A	System Alarm (default) /On Battery /Battery Low Capacity /UPS Fault / On Bypass / UPS /Remote EPO / Main input abnormal / On Maintenance Bypass / Load Shed Signal 1 / Load Shed Signal 2 / Internal MBB Closed.	
J14 ²	Output dry contact and REPO port	7	Summary_Alarm_B	System Alarm (default) /On Battery /Battery Low Capacity /UPS Fault / On Bypass / UPS /Remote EPO / Main input abnormal / On Maintenance Bypass / Load Shed Signal 1 / Load Shed Signal 2 / Internal MBB Closed. Pin5 and Pin7 shorted for alarm state. Note: We recommend adopting the switch with normally-closed auxiliary contact when load shed signal is selected	Configurable input dry contact J14-5/7
		2	REPO_NC	Trigger EPO upon Pin2 and Pin4 opened	
		4	+12V_EPO		
		6	+12V_EPO	Trigger EPO upon Pin6 and Pin8 shorted	
		8	REPO_NO		
J15 ²	Battery BCB port	1	BCB_DRIVE	BCB tripping drive, normally 0V, 12V tripping	
		2	BCB_STATUS	BCB switch status signal	
		3	GND_SELV	GND	
		4	BCB_ONLINE	BCB on line	
J16 ³	Rectifier back-feed output port	1	MFP_O	Rectifier back-feed normally open contact. Closed when there is rectifier back-feed	
		2	MFP_S	Rectifier back-feed common contact	
		3	MFP_C	Rectifier back-feed normally closed contact. Open when there is rectifier back-feed	

Silkprint	Port name	Pin No.	Pin name	Meaning	Remarks
J17 ³	Bypass back-feed output port	1	BFP_O	Bypass back-feed normally open contact. Closed when there is bypass back-feed	
		2	BFP_S	Bypass back-feed common contact	
		3	BFP_C	Bypass back-feed normally closed contact. Open when there is bypass back-feed	



1. Capacity of input dry contact port J13: 12Vdc, 20mA.
2. Capacity of output dry contact ports J14 and J15: 24Vdc, 0.5A.
3. Capacity of output dry contact ports J16 and J17: 250Vdc, 5A.
4. If REPO is required: Pin6 and Pin8 are reserved, and Pin2 and Pin4 of J14 are shorted before delivery;
If Normally Closed switch is configured as REPO, remove the shorting cable between Pin2 and Pin4, and then adopt the shielded cable to connect Pin2 and Pin4 with the switch;
If Normally Open switch is configured as REPO, reserve the shorting cable between Pin2 and Pin4, and then adopt the shielded cable to connect Pin6 and Pin8 with the switch.
5. If configurable input dry contact is configured as 'Start Battery Maintenance Self-check' or 'Stop Battery Maintenance Self-check' or 'Alarm Cleared', the rising edge triggering will be effective; if configurable input dry contact is configured as other functions, the level triggering will be effective.



Activating the UPS EPO will close the rectifier, inverter, bypass and battery, but does not disconnect the UPS mains input inside. If you wish to disconnect the UPS completely, it is also necessary to open the internal input switch and unplug the battery terminals when activating the EPO.

In the event of an emergency, trigger the REPO switch (supplied and installed by the user) in order to shut down the rectifier and inverter, and turn off the UPS. Under normal conditions, the REPO switch cannot be used to isolate the UPS from the mains input power. If an electronically controlled circuit breaker function is installed at the UPS input, the REPO switch can be used to trip this breaker, thus cutting off the UPS mains input power. The position of the REPO switch is shown in Figure 7-6, and the REPO cable connection is shown in Figure 7-7 and Figure 7-8.

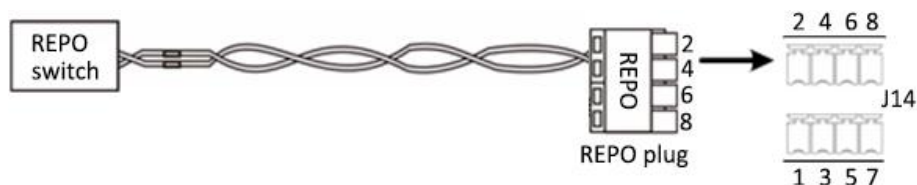

Figure 7-7 REPO (Normally Closed) cable connection



Figure 7-8 REPO (Normally Open) cable connection



1. Ensure that the plug of REPO have been correctly connected to the corresponding Pin of port J14, and that the REPO cable is securely connected to ensure that the REPO is not activated inadvertently as the result of poor contacts.
2. When the REPO switch is triggered at the user-end, the UPS generates an alarm and immediately cuts off the output, and the UPS does not automatically return to the normal operating state. At this point, it is necessary to change the REPO switch state, and the UPS manually switched on.
3. REPO switch is only valid for the specified unit in parallel system.



1. We recommend using $0.82\text{mm}^2 \sim 0.33\text{mm}^2$ signal cable (18AWG~33AWG), the cable length should not be more than 10m.
2. If the REPO has been configured to trip an electronically controlled circuit breaker switch, after the REPO has been activated it will be necessary to re-arm the switch before restarting the UPS.

7.3 Connecting Parallel Cables

See Figure 7-6 for the connection port.

Refer to Figure 6-2 for the connection of parallel cables.

7.4 Connecting LBS Cables

See Figure 7-6 for the connection port.

Refer to Figure 6-6 and Figure 6-7 for the connection of LBS cables.

8 Maintenance

This chapter focuses on the UPS maintenance, including the fan maintenance, battery maintenance, UPS cleaning, UPS state check, UPS function check.



Never attempt to carry out maintenance on the UPS while it is on line. Ensure that the UPS has been switched off completely when performing any internal maintenance operations on it.

8.1 Fan Maintenance



In order to avoid injury or damaging the device, wait until the fan is completely stationary before inserting fingers or any tools into it.

The UPS fans are expected to run for 20,000 hours ~ 40,000 hours in continuous operation. The higher the ambient temperature, the shorter the fan life.

During the UPS operation, it is important to check the condition of the fans regularly by confirming that they blow air out of the ventilation holes on the rear panel.

8.2 Battery Maintenance



1. *Never invert the battery connections as this could result in fires.*
2. *Never attempt to open batteries since they contain electrolyte which is potentially harmful to personnel. In the event of accidental with electrolyte, wash the affected area with abundant, clean water, and seek medical assistance immediately.*

The internal battery module of the UPS is sealed, lead-acid free and maintenance-free battery. The battery life depends on the ambient temperature, charge and discharge times. High ambient temperature and deep discharge shortens the battery life.

To ensure the battery life, it is required to:

- Keep the ambient temperature ranging from 15°C to 25°C
- Prevent small current discharge. Continuous battery operation time exceeding 24 hours is strictly prohibited
- Charge the battery for at least 12 hours, if the battery hasn't been charged for three months at specified ambient temperature, or two months at high ambient temperature



1. Check the battery connection screws are regular intervals, and re-tighten them if necessary.
2. Make sure that all the safety devices present, in good condition and that they function correctly, and make sure that the battery management parameter settings are correct.
3. Measure and log the ambient temperature in the battery room.
4. Check whether the battery ports are damaged or hot, and check the condition of the chassis and the covers.

If any of the batteries are found to be leaking, place them in a suitable container and dispose them in accordance with local regulations.

Lead-acid batteries are classified as hazardous waste material. The control of waste battery pollution is a nationally important issue. Batteries must be stored, transported, used and disposed in accordance with national and local legal requirements and all other criteria applicable to the treatment of hazardous waste material and waste battery pollution prevention.

According to the applicable regulations, waste lead-acid batteries must be recycled, while all other disposal methods are prohibited. Uncontrolled or random disposal of waste lead-acid batteries, or other improper disposal methods can result in serious environmental pollution, which will be investigated by the relevant authorities.

As the provider of lead-acid batteries, Vertiv has developed a dedicated service network and waste battery recycling system to assist users to legally dispose of waste batteries. Contact Vertiv or your nearest service center for detailed information about the waste battery the recycling system.

Vertiv may not be held liable for the environmental impact resulting from the failure to comply with the guidelines set out in this section, or to use the waste battery recycling system offered by Vertiv.

8.3 Cleaning UPS

To ensure free airflow inside the UPS: Clean the UPS periodically, especially the ventilation holes. If necessary, clean the UPS with a vacuum cleaner. Confirm that the ventilation holes are unobstructed.

8.4 Checking UPS State

We recommend checking the operational state of the UPS regularly.

Check the following items:

1. Check for any UPS fault conditions: Is the alarm indicator on? Are there any UPS alarms active?
2. Check if the UPS is operating in Bypass mode. Under normal conditions, the UPS operates in Normal mode; if you find that it is operating in Bypass mode, determine the reason (operator intervention, overload, internal fault, etc.)
3. Check if the battery is discharging: When the AC mains supply is within normal limits, the battery should not be discharging; if you find that it is operating in Bypass mode, determine the reason (mains failure, battery test, operator intervention, etc.).

8.5 Checking UPS Functions



UPS functions check procedures may cause power interruption to load!

We recommend checking the UPS functions regularly.

Backup the load data before conducting the UPS functional check. The procedures are as follows:

1. Press the power button to check if the buzzer beeps, the indicators are on and the LCD display is normal.
2. Press the ESC key and check again that the indicators are on, the LCD display is normal, and that the UPS has been transferred to inverter mode.

9 Options

This chapter introduces the options that are available for the UPS.

9.1 List of Options

See Table 9-1 for the list of the available options.

Table 9-1 List Of options

Option name	External model	Code	Note
UPS parallel cable	EXS 0040kTH16FN01SL10	/	UPS parallel cable (5m)
	EXS 0040kTH16FN01SL11	/	UPS parallel cable (10m)
	EXS 0040kTH16FN01SL12	/	UPS parallel cable (15m)
LBS cable	UHRF3S67SL8	04118683	LBS cable (5m)
	UHRF3S67SL9	04118684	LBS cable (10m)
	UHRF3S67SL10	04118685	LBS cable (15m)
	UF-LBS01-50	0235A04V	LBS extension cable (50m); to be released at phase 2
	UF-LBS01-150	0235A04Y	LBS extension cable (150m); to be released at phase 2
SIC card	UF-SNMP810	02351817	Option for intelligent card; to be released at phase 2
IS-RELAY card	IS-RELAY	02351105	Option for intelligent card
IS-UNITY-DP card	IS-UNITY-DP	03020728	
IS-UNITY-LIFE card	IS-UNITY-LIFE	03020753	
Internal battery temperature sensor	EXS 0060kBDS01	/	
External battery temperature sensor	IRM-S01T	02311725	
KAIC assembly	EXS 0060kKIC01	/	
Backfeed assembly	EXS 0060kBFP01	/	
32-block battery tray kit	EXS 0060kBTS01	/	Battery excluded
40-block battery tray kit	EXS 0060kBTS02	/	Battery excluded
1*40-block battery cabinet	EXS 0060kBCE01	/	Battery excluded
2*32-block battery cabinet	EXS 0060kBCE02	/	Battery excluded
Bypass load-sharing inductor kit	EXS 0060kBIS01	/	Assembled before delivery
Input transformer kit	EXS 0060kIIT01	/	Assembled before delivery; to be released at phase 2
Output transformer kit	EXS 0060kOIT01	/	Assembled before delivery; to be released at phase 2
Remote status panel kit	EXS 0040kRSP01	/	To be released at phase 2
CPSS display panel	EXS 0040kCPS01	/	To be released at phase 2
Air filter kit	EXS 0060kAFS01	/	Assembled before delivery

Option name	External model	Code	Note
Seismic anchor kit	EXS 0060kSAS01	/	Assembled before delivery
EMC C2 kit	EXS 0060kEMC01	/	To be released at phase 2
IP31 kit	EXS 0060kIPS01	/	To be released at phase 2
BCB	EXS 0060kBCB01	/	BCB box, used to connect and control the external battery string
Battery ground fault kit	EXS 0060kBGF01	/	Used together with BCB

9.2 Parallel Cables

Communication cable is compulsory in parallel system. See Table 9-2 for cable description. Refer to 6.3.4 *Connecting Parallel Cables for the methods to connect the parallel cables*.

Table 9-2 Description of the Parallel Cables

Type	Description	Appearance
EXS 0040kTH16FN01SL10	For N + 1 parallel system, N + 1 communication cables (5m) are required. For example, two communication cables are required in 1 + 1 parallel system; three communication cables are required in 2 + 1 parallel system; four communication cables are required in 3 + 1 parallel system	
EXS 0040kTH16FN01SL11	For N + 1 parallel system, N + 1 communication cables (10m) are required	
EXS 0040kTH16FN01SL12	For N + 1 parallel system, N + 1 communication cables (15m) are required	

9.3 LBS Cables

The LBS cables are compulsory in dual-bus system. See Table 9-3 for cable description. Refer to 6.5.4 *Connecting LBS Cables for the methods to connect the LBS cables*





Table 9-3 Description of the LBS cables

Type	Description	Appearance
UHRF3S67SL8	LBS cable (5m)	
UHRF3S67SL9	LBS cable (10m)	
UHRF3S67SL10	LBS cable (15m)	
UF-LBS01-50	LBS extension cable (50m)	
UF-LBS01-150	LBS extension cable (150m)	

9.4 Communication Options and Temperature Sensor

The communication options and temperature sensor are listed in Table 9-4.

Table 9-4 Communication options and temperature sensor

Name	Type	Description	Appearance
SIC card	UF-SNMP810	Remotely monitor UPS through TCP/IP protocol and Internet; Support remote safe shutdown; Provide an extended net port, cascade-connect up to eight temperature sensors	
IS-UNITY-DP card	IS-UNITY-DP	For further description of the IS-UNITY-LIFE card, refer to <i>Liebert IntelliSlot™ Unity Card User Manual-Web, SNMP, Modbus, BACnet, YDN23</i>	
IS-UNITY-LIFE card	IS-UNITY-LIFE	For further description of the IS-UNITY-LIFE card, refer to <i>Liebert IntelliSlot™ Unity Card User Manual-Web, SNMP, Modbus, BACnet, YDN23</i>	
IS-RELAY card	UF-DRY410	For more information of the IS-Relay card, refer to the <i>Liebert IntelliSlot IS-Relay Card User Manual</i>	
Internal battery temperature sensor	EXS 0060kBDS01	With LCD screen, connects the SIC card or the multifunction port	
External battery temperature humidity sensor	IRM-S01T		

9.5 BCB Box

9.5.1 Overview

The BCB box contains a BCB and a BCB control board.

Vertiv provides the BCB box for use when installing an external battery. In this situation, The BCB box is installed as close as possible to the battery and connected to the UPS. Refer to *Figure 9-1, Table 9-5 and Table 9-6 for description of the BCB box and its components.*

The BCB box protects the battery against overdischarge and overcurrent, and isolates the UPS and battery, thereby reducing the risk at lowest for service personnel during the maintenance. The box inside has connection bars for connecting the power cables from the UPS and batteries.



The signal cables from the UPS to the BCB control board must be routed in a separate cable trough and separated from battery power cables. The separate safety earth must be connected at the UPS side.

Table 9-5 Parameters of BCB box

Dimensions (H × W × D) (mm)	Weight (kg)	CB	CB instantaneous setting current
252×450×636	13	225A (3P)	2250A



This weight excludes the packaging.

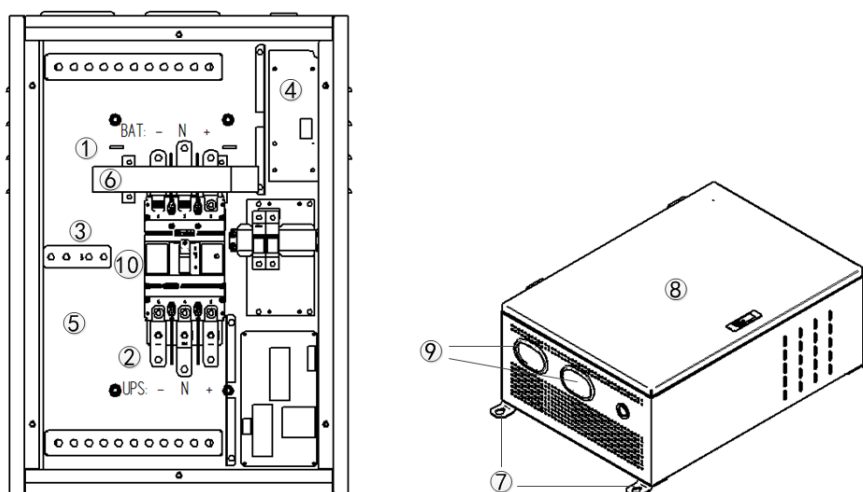

Figure 9-1 BCB box

Table 9-6 Description of BCB box components

No.	Component
1	Battery connection terminal (BAT+/BAT N/BAT-)
2	UPS connection terminal (UPS+/UPS N/UPS-)
3	Grounding bar
4	Battery switch control board
5	Base plate
6	Current sensor to be installed when selecting battery ground fault kit
7	Wall-mounted installation hole
8	Protective door
9	Cabling hole for confirming the cable size and opening hole
10	Battery switch

9.5.2 Connection of BCB Box

Refer to Figure 9-2 for the connection among battery, BCB and UPS.

Refer to Table 9-7 for the communication cable's definition between the UPS and BCB.

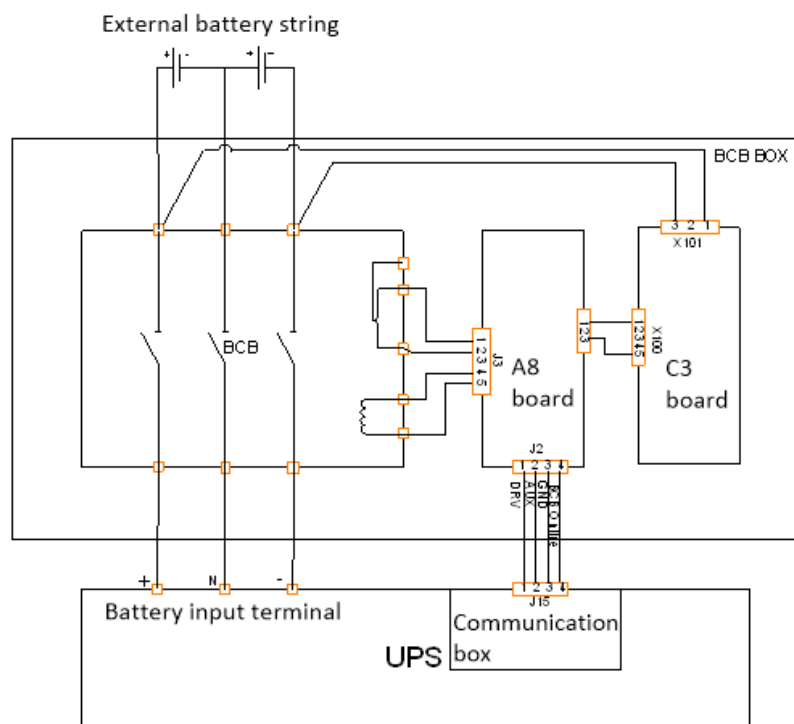

Figure 9-2 Connection of BCB box

Table 9-7 Battery control port (X102)

BCB box port	Communication box port	Meaning	Signal state
DRV	BCB_DRIVE	Tripping control signal of BCB from the UPS	BCB tripping drive Normal: 0V Tripping: 12V
AUX	BCB_STATUS	Auxiliary contact of BCB (contact off means BCB off)	Normal: 0V, BCB closed; Abnormal: open, BCB open
GND	GND	Signal ground	GND to GND
BCB_ONLINE	BCB_ONLINE	BCB online state	To GND by default



The cable of the J2 BCB port must be routed separately from the power cable. It uses the dual-insulated shielded cable (the CSA is generally $0.5\text{mm}^2 \sim 1\text{mm}^2$ when the max. wiring distance is 30m), and the UPS side of the shielding coat must be connected to the enclosure reliably.



If the corresponding functions are not required, just do not connect corresponding terminals.

10 Specifications

This chapter lists the UPS specifications.

10.1 Conformance and Standards

Table 10-1 Conformance and standards

Item	Standard
Conduction emission	IEC/EN62040-2 Standard product meets Class C3, the product with C2 option installed meets Class C2
EFT	IEC/EN62040-2: AC port withstand pulse group impact of 4kV/5kHz
Harmonic current	IEC/EN62040-2, $16A < I \leq 75A$
Input voltage flash	IEC/EN62040-2, $16A < I \leq 75A$
Electrostatic discharge immunity	IEC/EN62040-2: Level 3
Radiation immunity	IEC/EN62040-2: Level 3
PFMF	IEC/EN62040-2: Level 4
Surge protection	Meets IEC/EN62040-2: live line to earth withstand level 4 (4kV); withstand level 3 between live lines (2kV)
Safety	IEC/EN62040-1
SPD test	Meets ANSI C62.41: live line to earth withstand 6kV/3kA Meets YD/T944: live line to earth withstand 5kA

10.2 Environmental Characteristics

Table 10-2 Environmental Characteristics

Item	Unit	Meaning
Noise within 1m (in the front)	dB (A)	<60
Altitude	m	≤ 1500 , non-derating; ≥ 1500 (derate power by 1% per 100m); up to 3000
Relative humidity	%RH	5 ~ 95%, non condensing
Operating temperature	°C	0 ~ 40°C (Note: Battery life is halved for every 10°C increased when above 20°C)
Storage and transport ation temperature for UPS	°C	-40°C ~ +70°C (battery excluded), -20°C ~ +30°C (battery included)
Over-voltage level		Overvoltage level 2
Pollution level		Pollution level 2

10.3 Mechanical Characteristics

Table 10-3 Mechanical Characteristics

Item	Unit	Rated power (kVA)	
		60	
		Internal battery excluded	Internal battery included (1*40-block)
Dimensions (W × D × H)	mm	600×850×1600	
Net weight	kg	215	666
Gross weight	kg	245	696
Color		Black	
Protection degree		IP20 (front door open or closed)	

10.4 Electrical Characteristics (Input Rectifier)

Table 10-4 Rectifier AC input (mains)

Item	Unit	Rated power (kVA)	
		60kVA	
Rated AC input voltage	Vac	380/400/415 (Line voltage)	
Input voltage range	Vac	176 ~ 275, at full load; 132 ~ 176, derated	
Frequency	Hz	50/60 (range: 40 ~ 70)	
Power factor	kW/kVA, full load (half load)	0.99 (0.98)	

10.5 Electrical Characteristics (Battery)

Table 10-5 Battery

Item	Unit	Rated power (kVA)	
		60kVA	
Type		Sealed, lead-acid, maintenance-free battery	
Battery cell	Block	Internal battery: 2*32-block or 1*40-block External battery: 32/34/36/38/40-block, at full load; 26/28/30-block, derated	
Max. charge current	A	25	

10.6 Electrical Characteristics (Inverter Output)

Table 10-6 Inverter output (to critical load)

Item	Unit	Rated power (kVA)
		60kVA
Rated AC voltage	Vac	380/400/415 (Line voltage)
Frequency	Hz	50/60
Overload	%	For linear load requirement: < 105%, continues; 105 ~ 110% of rated load, 60min; 110 ~ 125% of rated load, 10min; 125 ~ 150% of rated load, 1min; > 150%, 200ms
Rated power factor		1
Crest factor		3:1
Voltage harmonic distortion	%	< 2% (linear load); < 5% (non-linear load)
Dynamic response recovery time	ms	60
Frequency synchronization range	Hz	Rated frequency \pm 3Hz. Configurable range: \pm 0.5Hz ~ \pm 3Hz
Frequency track rate	Hz/s	0.5Hz/s. Configurable range: 0.1~0.6Hz/s (single UPS), 0.6Hz/s (parallel system)
Mains efficiency	%	Up to 96.2%

10.7 Electrical Characteristics (Bypass Input)

Table 10-7 Bypass input

Item	Unit	Rated power (kVA)
		60kVA
Rated AC voltage	Vac	380/400/415 (Line voltage)
Overload	%	< 110%, continues; 110 ~ 125% of rated load, 10min; 125 ~ 150% of rated load, 1min; 150, 200ms
Frequency	Hz	50/60 (Range: 40~70)
Bypass voltage tolerance	%Vac	Upper limit: +20%; settable: +10%, +15% or +20%; default: +15% Lower limit: -40%; settable: -10%, -20%, -30% or -40%; default: -20%
Synchronisation window	Hz	Rated frequency \pm 3; \pm 0.5 ~ \pm 3 (optional)

Appendix 1 LCD Parameters Setting

Menu	Item	Setting range	Default setting
System	Battery auto equalize	Disable, Enable	Disable
	ECO mode	Disable, Enable	Disable
Monitor	Language	Chinese, English, Deutsch, Italiano, Français, Čeština, Nederlands, Português, Svenska, Türkçe, Español, Русский, Polski	English
	Date format	YY/MM/DD, MM/DD/YY, DD/MM/YY	MM/DD/YY
	Date	MM-DD-YY	01-01-2018
	Time	HH: MM: SS	00: 00: 00
	Audible alarm	Disable, Enable	Disable
	Serial port 1 baudrate	1200bps, 2400bps, 4800bps, 9600bps, 19200bps	9600bps
	Serial port 2 baudrate	1200bps, 2400bps, 4800bps, 9600bps, 19200bps	9600bps
	UPS address	Ddd ('d' is a decimal number)	001
	Card slot protocol	YDN23, Velocity	YDN23
	Change settings password	The password is numeric only and can be set from 0 to 9. The password length is 6	111111
Control	Mute/Unmute audible alarm	/	/
	Clear faults	/	/
Maintain	Start maintenance guide	/	/
	Exit maintenance guide	/	/
	Battery maintenance test	/	/
	Battery capacity test	/	/
	Stop battery test	/	/
	Equalize charge		
	Stop equalize charge	/	/
	Battery reset	/	/

Appendix 2 Glossary

AC	Alternating current
CB	Circuit breaker
CSA	Cross sectional area
DC	Direct current
DIP	Dual in-line package
DSP	Digital signal processor
EMC	Electromagnetic compatibility
EMI	Electromagnetic interference
EOD	End-of-discharge
EPO	Emergency power off
I/O	Input/output
LBS	Load bus synchronizer
LCD	Liquid crystal display
LED	Light-emitting diode
MCB	Miniature circuit breaker
NMS	Network management system
PE	Protective earth
RCCB	Residual current circuit breaker
RCD	Residual current detector
REPO	Remote emergency power off
RFI	Radio frequency interference
SCR	Silicon-controlled rectifier
SNMP	Simple network monitoring protocol
STS	Static transfer switch
UPS	Uninterruptible power system
AC	Alternating current

Appendix 3 Hazardous Substances and Content

Parts	Hazardous substances					
	Plumbum	Hydrargyru	Cadmium	Chrome ⁶⁺	PBB	PBDE
	(Pb)	(Hg)	(Cd)	(Cr(VI))	(PBB)	(PBDE)
PCBA	○	○	○	○	○	○
AC capacitor	○	○	○	○	○	○
DC capacitor	○	○	○	○	○	○
Fan	○	○	○	○	○	○
Cables	○	○	○	○	○	○
LCD	○	×	○	○	○	○
Sensors	○	○	○	○	○	○
Large-medium power magnetic components	○	○	○	○	○	○
Circuit breaker	○	○	○	○	○	○
Semiconductors	○	○	○	○	○	○
Battery (when applicable)	×	○	○	○	○	○
Insulation monitoring device (when applicable)	N/A	N/A	N/A	N/A	N/A	N/A
<p>This table is made following the regulation of SJ/T 11364.</p> <p>○: Means the content of the hazardous substances in all the average quality materials of the parts is within the limits specified in GB/T 26572</p> <p>×: Means the content of the hazardous substances in at least one of the average quality materials of the parts is outside the limits specified in GB/T 26572.</p> <p>About battery: Generally follow the environmental protection use period of the battery, otherwise five years.</p> <p>Applicable scope: Liebert® EXS 60kVA UPS</p>						



Vertiv.com

© 2019 Vertiv Co. All rights reserved. Vertiv and the Vertiv logo are trademarks or registered trademarks of Vertiv Co. All other names and logos referred to are trade names, trademarks or registered trademarks of their respective owners. While every precaution has been taken to ensure accuracy and completeness herein, Vertiv Co. assumes no responsibility, and disclaims all liability, for damages resulting from use of this information or for any errors or omissions. Specifications are subject to change without notice.